

USER GUIDE

UGG045-0216

CUP Series

Models CUP-36, CUP-48, and CUP-60

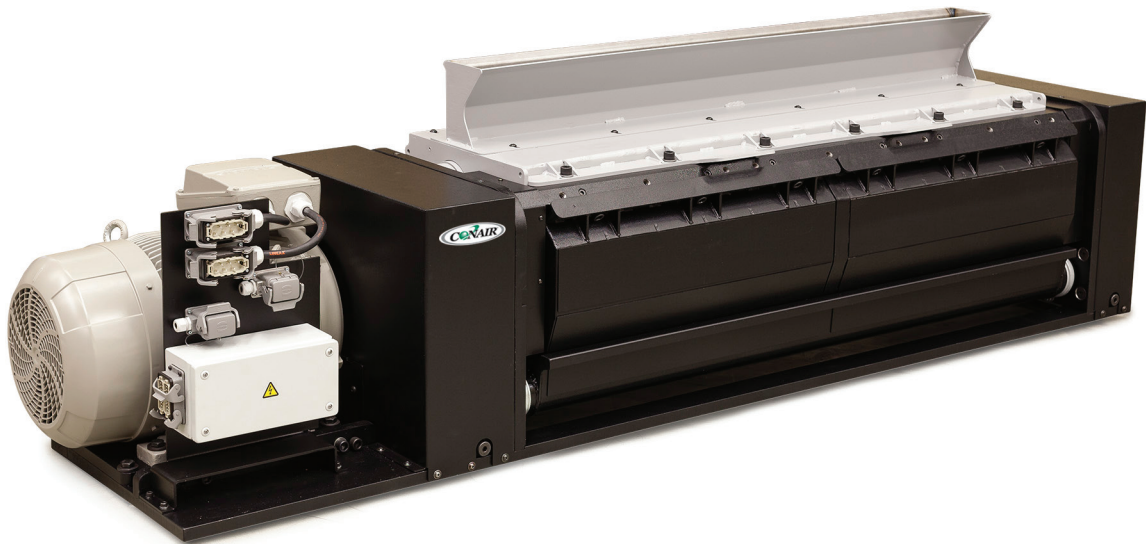

Please record your equipment's model and serial number(s) and the date you received it in the spaces provided.

It's a good idea to record the model and serial number(s) of your equipment and the date you received it in the User Guide. Our service department uses this information, along with the manual number, to provide help for the specific equipment you installed.

Please keep this User Guide and all manuals, engineering prints and parts lists together for documentation of your equipment.

Date: 08/2015

Manual Number: UGG045-0216

Serial Number(s):

Model Number(s): CUP-36, CUP-48, and CUP-60

DISCLAIMER: Conair shall not be liable for errors contained in this User Guide or for incidental, consequential damages in connection with the furnishing, performance or use of this information. Conair makes no warranty of any kind with regard to this information, including, but not limited to the implied warranties of merchantability and fitness for a particular purpose.

Introduction



Note! All users must study the instruction manual before installing, operating or maintaining the machine.

This instruction manual contains instructions how to install, operate and maintain the standard versions of the Conair CUP series granulators, Models CUP-36, CUP-48, and CUP-60, Additional suffix -U, -RF, -AX.

The performance of your supplied machine may vary from the standard machines described in this instruction manual. In event of any questions, please contact Conair's local distributor or Conair's head office.

Conair Group
200 West Kensinger Drive
Cranberry Township, PA 16066

Phone: +1 724 584 5500
Fax: +1 724 584 5299

Website: www.conairgroup.com
E-mail: info@conairgroup.com

1. SAFETY RULES

General rules, Safety	1:1
Symbols on the machine	1:1
Symbols in the instruction manual	1:1
Safety rules, During installing	1:2
Safety rules, During start and operation	1:2
Safety rules, During service	1:3
Risk of machinery damage	1:3

2. DESCRIPTION

Technical specifications	2:1
General data, Supplied machine:	2:1
General data, CUP-series:	2:1
Personnel responsible for the machine's service and safety:	2:1
Overview	2:2
Layout	2:3
Function	2:13
Conair CUP-series	2:13
Additional suffix -U	2:14
Additional suffix -RF	2:14
Additional suffix -AX	2:14
Rotor	2:15
General rules, Rotor	2:15
Staggered rotor	2:15
Rotating knives	2:15
Cutter housing	2:16
General rules, Cutter housing	2:16
Cutter housing 1st	2:16
Fixed knives	2:16
Grinding fixture	2:17
Knife clearance	2:17
Presetting fixture	2:17
Transmission	2:18
Motor	2:18
Drive belt(s), Motor pulley, Rotor pulley	2:18
Flywheel	2:18
Safety equipment	2:19
General rules, Safety equipment	2:19
Safety equipment	2:20
Inlet	2:20
Roller feeder	2:20
Screen, Screen box	2:20
Granule bin	2:20

2. DESCRIPTION

Safety equipment	2:20
Main switch	2:21
Emergency stop(s)	2:21
Key to electrical cabinet	2:21
Stand still monitor	2:21
Safety clamp	2:22
Safety switch	2:22
Safety relay	2:23
Overload protection	2:23
Operating panel	2:23
General rules, Level switch	2:24
Level switch, Paddle type	2:24
Hours counter	2:24
Function settings Current relay - overcurrent detector	2:25
Application of current relay	2:25
Parameters that affects overcurrent detection.	2:25
Check of function settings overcurrent detection	2:25

3. TRANSPORT / LIFT

Transport / Lift	3:1
General rules, Transport / Lift	3:1
Transport	3:1
Lift the granulator	3:1
Store the granulator	3:1

4. INSTALLING

Actions before first start	4:1
General rules, Installing	4:1
Reception inspection	4:1
Put the machine in its working place	4:1
Remove the rust preventer	4:1
Check the knife clearance	4:1
Technical specifications	4:1
General rules, Electrical connection	4:2
Emergency stop	4:2
Level switch (optional)	4:2
Current relay (optional)	4:2
Connect the granulator to the mains	4:2

Start the granulator 4:3
 Checks immediately after first start 4:3
 Checks 30 hours after first start 4:3
 Installing complete 4:3

5. START / STOP

Start the granulator 5:1
Stop the granulator 5:1
Start the roller feeder..... 5:2
 Adjust the roller speed 5:3
 Start feeding 5:3
 Stop the roller feeder 5:4

6. OPEN / CLOSE

Open the granulator..... 6:1
 General rules, Open the granulator 6:1
 Open the transmission inspection hatch 6:1
 Open the transmission 6:1
 Remove the safety clamp 6:2
 Remove the granule bin 6:2
 Open the screen box 6:2
 Open the hopper 6:3
 General rules, Close the granulator 6:4
 Close the hopper 6:4
 Close the screen box 6:4
 Close the transmission inspection hatch 6:4
 Install the granule bin 6:5
 Mount the safety clamp 6:5

7. SERVICE

General rules, Service 7:1
 Emergency stop(s) 7:1
 Lubrication 7:1
 Service schedule 7:1
Safety equipment 7:2
 Electrical components 7:2
Safety relay 7:3

Level switch 7:3
Current relay 7:4
 Important tightening torques 7:5
Cleaning 7:6
Knives 7:7
 General rules, Knives 7:7
 Knives 7:8
 Remove the rotating knives 7:8
 Remove the fixed knives 7:8
 General rules, Grind the knives 7:9
 Grind the fixed knives 7:9
 Grind the rotating knives 7:10
 General rules, Preset the knives 7:11
 Preset the rotating knives 7:11
 Preset the fixed knives 7:11
 Install the fixed knives 7:12
 Install the fixed knives 7:13
 Install the rotating knives 7:14

Drive belt(s) 7:15
 General rules, Drive belt(s) 7:15
 Check the drive belt(s) 7:15
 Adjust the belt tension 7:15
 Belt tension table 7:16

Fault tracing 7:17

8. SERVICE REPORT

Service actions, Once every day 8:1
Service actions, Once every week 8:2
Service actions, Once every month 8:3
Service actions, Once every 6th month 8:3
Other remarks 8:4

9. SPARE PARTS

Spare Parts 9:1

10. APPENDIX

Customer Service Information A:1
Warranty Information..... A:2

General rules, Safety

Conair designs granulators, shredders, guillotines and accessory equipment for processing injection moulded, blow moulded or extruded plastics. The machines are designed and adapted to the type of plastic residue that the customer has specified before order.

The machines are manufactured in accordance to the state of the art and legal safety regulations (guidelines, harmonised standards), which demand a very low safety risk. But, if the machines are incorrectly operated, unexpected dangers can arise. Therefore it is very important that all instructions are carefully observed and attended to. All users must study the instruction manual before installing, operating or maintaining the machine. In event of any questions, please contact Conair's local distributor or Conair's head office.



Danger! It is not permissible to feed the machine with explosive material or material contaminated with explosive or easily ignited substances. It is not permissible to feed the machine with wood products, household or garden waste, pharmaceutical products or substances which present a health danger, unless a written approval has been obtained from Conair's head office. If any materials are processed that are not contractually agreed upon, Conair is absolved of any liability and guarantee for safety and functioning of the machine.



Danger! No modifications or alterations to Conair's products are permissible unless a written approval has been obtained from Conair's head office. This is to prevent injury, to maintain the machinery warranty valid, and to guarantee that Conair can fully assume their product liability. If any modifications are done, Conair is absolved of any liability and guarantee for safety and functioning of the machine.

Symbols on the machine



Danger! Risk of cutting or pinch injuries! This symbol is placed anywhere there is a risk of cutting or pinch injuries.



Danger! Dangerous voltage! This symbol is placed on electrical cabinet hatches and on any junction boxes.



Request! All users must study the instruction manual before installing, operating or maintaining the machine.

Symbols in the instruction manual



Danger! Personal injury! This symbol is used to indicate risk of personal injury. The symbol inside the triangle may have different appearances, depending on the type of danger.



Danger! Machinery damage! This symbol is used to indicate risk of machinery damage.



Information! This symbol is used to highlight useful information.

Safety rules, During installing



- The machine must be installed by authorized, trained personnel.
- The machine must be disconnected from the mains before electrical repairs or electrical installing is begun.
- The instruction manual must be carefully observed to avoid personal injury and machinery damage.
- The machine must be installed and connected to other equipment so that the entire installation complies with the stipulations of the Machinery Directive 2006/42/EC.

Safety rules, During start and operation



- The instruction manual must be carefully observed to avoid personal injury and machinery damage.
- National environmental and employee safety regulations must be followed.
- The machine must be installed in accordance with this instruction manual..
- All covers must be installed. All hatches to electrical cabinet, transmission and pneumatics (if supplied) must be closed and locked. The key must be kept by the personnel responsible for the machine's service and safety.
- The screen must be installed.
- The screen box must be closed.
- The granule bin must be closed.
- The hopper / roller feeder must be closed.
- The inlet must be installed.
- All safety switches must be installed.
- All outer safety equipment such as protective screens, bars, covers, plates, nets etc must be installed.
- Body with wheels (optional): The wheels must be locked.



- Be very careful. The machine contains knives. Risk of cutting or pinch injuries!
- Never place any part of your body into any opening. Risk of cutting or pinch injuries!
- Use ear defenders. Risk of loud, damaging noise!
- Use protective goggles. Risk of granulate splashing!
- Do not tread on the machine.



- A granulator with additional suffix -K (Enclosure):
 - The enclosure must be closed during start and operation.



- A granulator with additional suffix -U (Blower):
 - Be very careful. The blower has a very powerful suction and blowing ability. Never place any parts of your body into or near any blower openings.
 - Blowers must not be used in ambient temperatures above +40°C, in ambient temperatures below -20°C, in explosion hazard atmospheres or unprotected outdoors.
 - The temperature of the transported material must never increase +80° C.

Safety rules, During service



- The instruction manual must be carefully observed to avoid personal injury and machinery damage.
- National environmental and employee safety regulations must be followed.
- First aid and eye shower must be within reach.
- Daily service and daily checks may be done by the operator. All other service and inspections must be done by authorised, trained personnel.
- Always work alone when service actions is performed.
- Use protective goggles and gloves.
- The machine must be stopped.
- The machine's main switch must be locked in position "0". Never insert any part of your body into any opening, unless the main switch is locked in position "0".
- The machine must be disconnected from the mains before electrical repairs or electrical installing is began.



- Be very careful – When opening and closing the machine. Risk of cutting or pinch injuries!
- Be very careful – When checking and changing drive belt(s). Risk of cutting or pinch injuries!
- Be very careful – When the machine is opened the knives are accessible. The knives are sharp, and they may cause personal injuries even when they are not rotating. The rotor can rotate by itself. Always lock the rotor with a piece of wood to prevent the rotor from self-rotating. Risk of cutting or pinch injuries!
- Be very careful – When pulling the rotor or the rotor pulley manually. Risk of cutting or pinch injuries!
- Be very careful – When cleaning. Granulate and plastic residue can make the floor slippery.
- Be very careful – When working on high level. Only use specially installed and fastened steps, stairs and platforms. It is not permissible to remove any outer safety equipment such as protective screens, bars, nets etc.
- After service / check is done all covers must be reinstalled. All hatches for electrical cabinet, transmission and pneumatics (if supplied) must be closed and locked. The key must be kept by the personnel responsible for the machine's service and safety.

Risk of machinery damage

- If incorrect material is fed into the machine.
- If the belt tension is incorrect or if the drive belt(s) is(are) worn.
- If the screen in the screen box is worn or incorrectly installed.
- If the knives' tightening screws are tightened with incorrect tightening torque.
- If the knife clearance is wrong.
- If the knives are blunt.

Technical specifications

General data, Supplied machine:

Fill in correct information, so that the data corresponds with the machine sign on your supplied machine:

Machine type:

Serial number:..... Manufacturing year:

Motor: V Hz kW Electrical circuit diagram:

General data, Conair CUP-series:

Mark the correct alternatives, so that the data corresponds with your supplied machine:

Model: CUP-36 CUP-48 CUP-60

Additional suffix: -U -RF -AX

Cutter housing (CH): 1st (Tangential)

Fixed knives (Reversible, Grindable): 6 pcs (2nd, 1st & 5th) (CUP-36) 6 pcs (2nd, 1st & 5th) (CUP-48)

..... 9 pcs (2nd, 1st & 5th) (CUP-60)

Rotor: 2-blade staggered

Rotating knives (Grindable): 6 pcs / 3x2 (CUP 36) 8 pcs / 4x2 (CUP 48) 10 pcs / 5x2 (CUP 36)

Screen Ø: 4 mm 5 mm 6 mm 8 mm 10mm 12 mm 17 mm 25 mm

Rotor speed: 575 rpm (50 Hz) 690 rpm (60 Hz)

Motor power: 11 kW 15 kW 18.5 kW 22 kW 30 kW Flywheel

Drive belt(s): 1 pcs

Weight 1530kg (G300-60)

Sound level*, Idle operation:

*(The specified sound level is dependent on granulator size, capacity, temperature etc).

Optional equipment: Grinding fixture Presetting fixture, Long

..... Level switch, Paddle type Hours counter

Current relay Current transformer: (1/A) LVA, Y/D-start: Rated current A / $\sqrt{3}$ = A

Setting on delivery: LV%: H%: LVA, Direct-start: Rated current A / 1 = A

Material transport Blower F25 Blower F25K. Blower F40 Blower F40K

Personnel responsible for the machine's service and safety:

Name:..... Phone:

Name:..... Phone:

Overview

The performance of your supplied machine may vary from the standard machines described in this instruction manual. In event of any questions, please contact Conair's local distributor or Conair's head office.

- Hopper (1)
- Inlet (2)
- Cover, Transmission (5)
- Transmission inspection hatch (3)
- Rotor pulley (6)
- Drive belt(s) (7)
- Motor pulley (8)
- Motor (9)
- Tightening screws (10)
- Adjusting screws (11)
- Motor mounting bracket tightening screw (12)
- Jack, Hopper (13)
- Cutter housing (14)
- Granule bin (18)
- Screen box* (19)
- Screen * (20)
- Start-button (21)
- Stop-button (22)
- Emergency stop (23)
- Button "Reset Safety Relay" (24)
- Button "Operate 1" (25)
- Button "Operate 2" (26)
- Hatch, Electrical cabinet (28)
- Lock, Electrical cabinet (29)
- Main switch (30)
- Hopper open/close (31)

* = 1 or 2 depending on machine width.

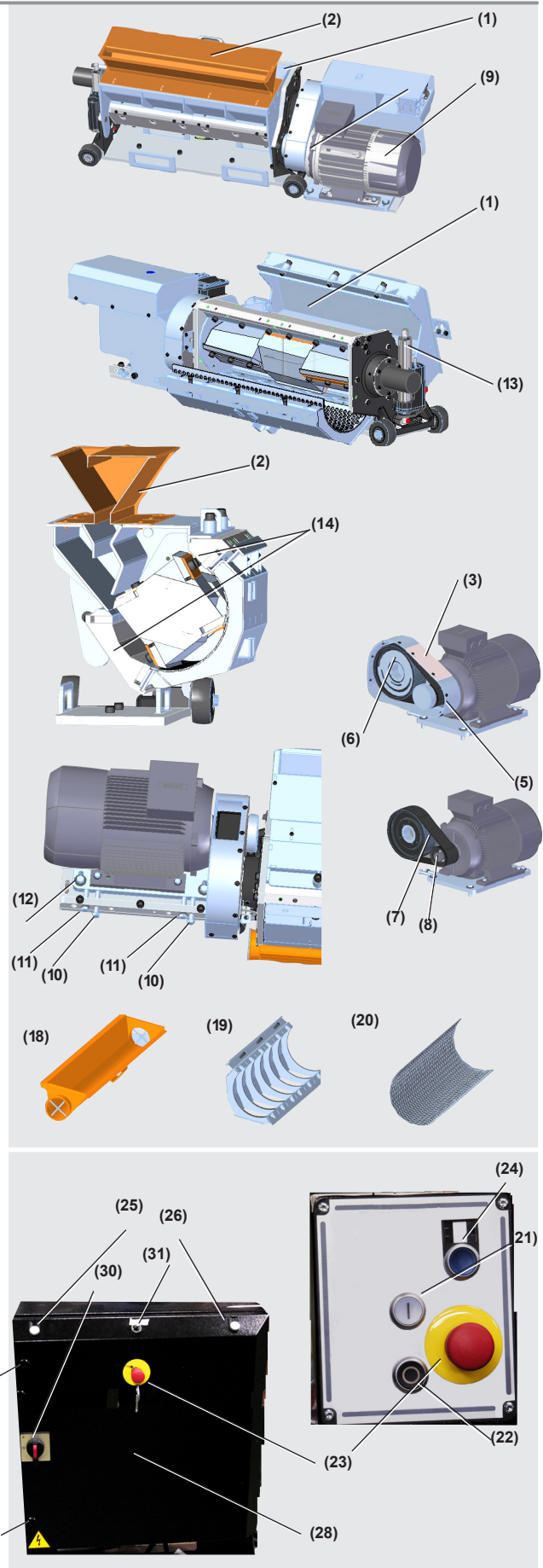

SPECIFICATIONS

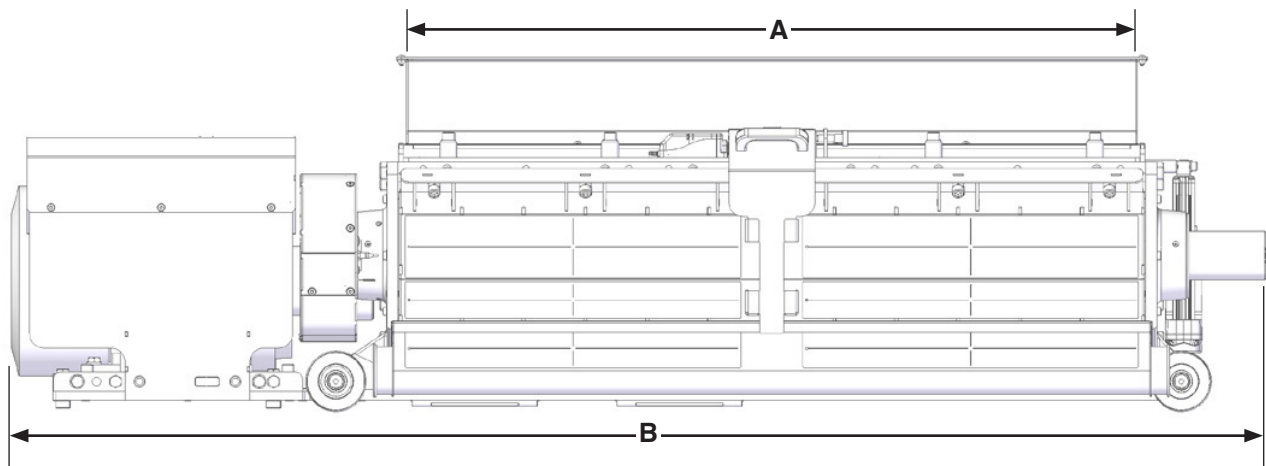

Front view

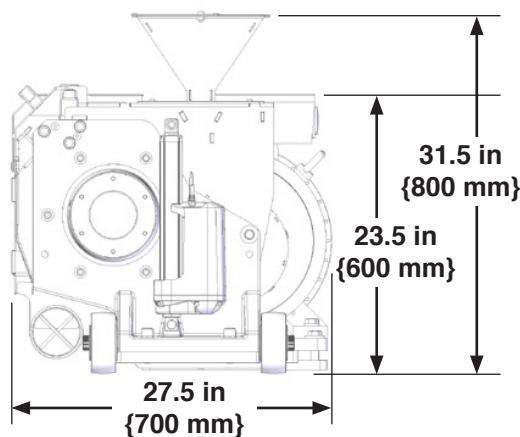

Side view

SPECIFICATION NOTE

* Throughput capacity is provided as a guideline. Throughput will vary according to screen size and the shape, size, and thickness of the material being cut.

Specifications can change without notice. Contact a Conair representative for the most current information.

OPTIONS

- **Roll feed**
A roll feed will synchronize with your line speed to feed plastic residue and scrap into the CUP.
- **Direct shredder recycling**
Further reduce granulate fed through a high-capacity Conair shredder like the SHX.
- **Film and sheet infeed**
Feed sheet up to 5/16-inch {8 mm}.
- **Blower**
Transport the granulate produced to a dust separation system, hopper or other container. Available with or without sound insulating enclosures.
- **Cyclone**
Separate air from the granulate produced by the CUP. The cyclone's air outlet can be provided with a filter for dust.
- **Open 3-blade rotor**
Maintain cooler cutting during large, taxing jobs. (Available on CUP-36 and CUP-48 only.)

MODELS	CUP-36	CUP-48	CUP-60
Performance characteristics			
Rotor diameter inches {mm}	12 {300}	12 {300}	12 {300}
Rotating knives	6	8	10
Fixed knives	6	6	9
Standard motor hp {kW}	10 {7.5}	15 {11}	15 {11}
Motor options hp {kW}	10 {7.5}, 15 {11}, 20 {15}, 25 {18.5}, 30 {22}, 40 {30}		
Standard screen diameter inches {mm}	1/4 {6}		
Screen diameter options inches {mm}	5/32 {4}, 5/16 {8}, 3/8 {10}, 1/2 {12}		
Throughput capacity* lbs/hr {kg/hr}	up to 1750 {800}	up to 2200 {1000}	up to 2600 {1200}
Dimensions inches {mm}			
Height	23.5 {600}	23.5 {600}	23.5 {600}
Height with standard infeed tray	31.5 {800}	31.5 {800}	31.5 {800}
Length	27.5 {700}	27.5 {700}	27.5 {700}
A - Infeed width	35 {900}	47 {1200}	59 {1500}
B - Total width	79 {2000}	90 {2300}	102 {2600}
Weight lb {kg}			
Installed	2600 {1200}	3000 {1350}	3300 {1500}

Function

Conair CUP-series

Conair CUP-series granulators are designed for granulating for example thermoforming residue. The function of the granulator can be described as follows:

1. The plastic residue, which must be free from metal and contamination, is fed into the granulator's inlet. The granulator can be provided with a roller feeder.
2. The plastic residue falls through the inlet / roller feeder and down into the cutter housing. The cutter housing contains fixed knives and a rotor.
3. Rotating knives are mounted on the rotor. The plastic residue is granulated (cut up) between the rotating knives on the rotor and the fixed knives in the cutter housing. Both rotating knives and fixed knives must be replaced or grinded as necessary.



Important! The granulator must never be used with blunt knives. Blunt knives cause abnormal wear and damages the granulator.

4. The size of the granulate (the cut up plastic residue) is determined by the screen. The screen is installed in the screen box in the base of the cutter housing. The screen can easily be changed to give the required granulate size.
5. The granulate passes through the screen down into the granule bin, which collects the finished granulate.
6. The granule bin must be emptied by means of a blower.

The granulator is adapted to be placed underneath an injection moulding machine.

Additional suffix -36, -48 and -60

The additional suffix -36, -48 and -60 refers to the cutter housing's width.

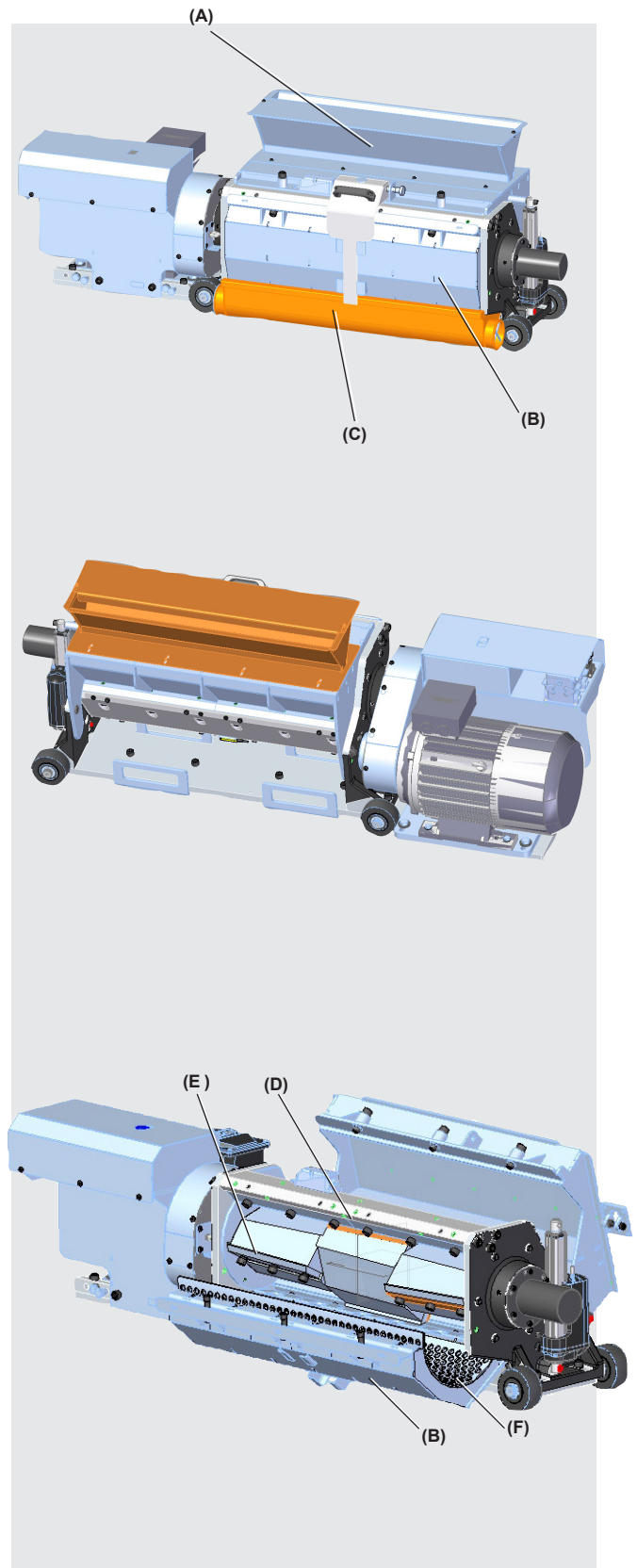

- (A) = Inlet
- (B) = Screen box
- (C) = Granule bin
- (D) = Fixed knife
- (E) = Rotating knife
- (F) = Screen

Function

Additional suffix -U

A granulator with additional suffix -U is provided with a blower. The blower transports granulate on from the granule bin to units such as a dust separation system or a granulate container for later use. Blowers are available with or without sound insulating enclosure.

Additional suffix -RF

A granulator with additional suffix -RF is provided with a roller feeder. The roller feeder contains rotating rollers which feed plastic residue into the granulator's cutter housing. Optional roller feeders; RFS, RFM. >Please refer to the separate instruction manual for roller feeder.

Additional suffix -AX

A granulator with additional suffix -AX is provided with a cyclone. The cyclone separates air from finished granulate. The cyclone's air outlet can be provided with a filter. Optional cyclones; AX7.5, AX12, AX.

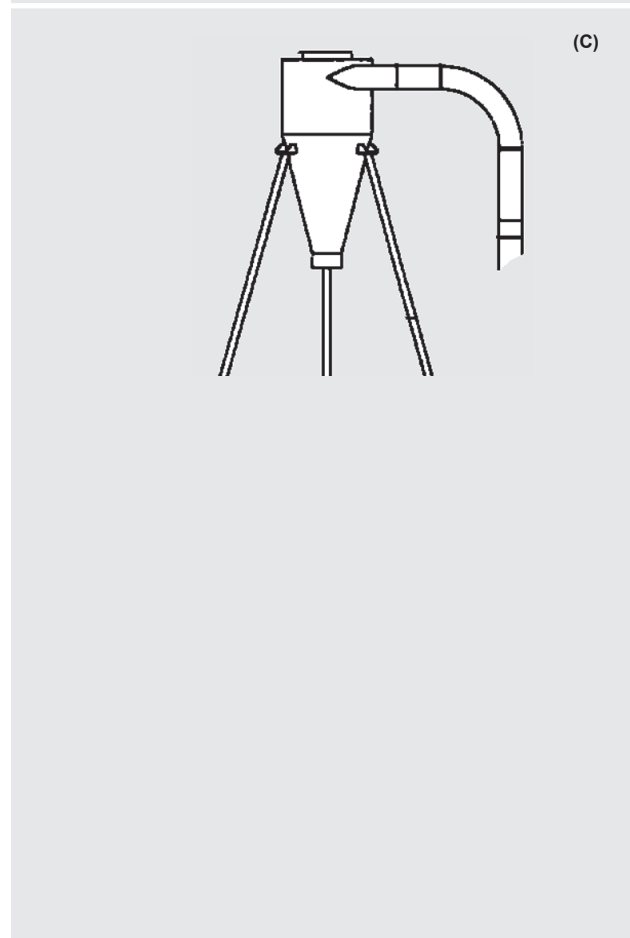
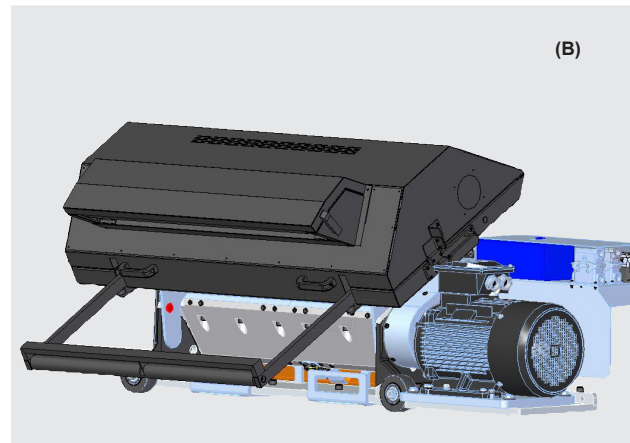
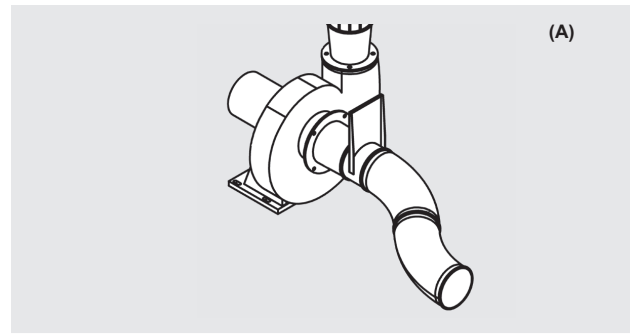

(A) = Blower (-U)
 (B) = Roller feeder (-RF)
 (C) = Cyclone (-AX)

Rotor

General rules, Rotor

The rotor is designed and adapted to the type of plastic residue that the customer has specified before order. The Conair CUP-series is provided with a staggered rotor.

Staggered rotor

The staggered 2-blade rotor has two staggered knife rows with 3, 4 or 5 rotating knives per row.

Rotating knives

Rotating knives are mounted on the rotor. The rotating knives are fixed with support rules and tightening screws. The knives are provided with adjusting screws which facilitates presetting of the knife clearance.
>Page 7:14 "Install the rotating knives".

The granulator must never be used with blunt knives. Blunt knives cause abnormal wear and damages the granulator. The rotating knives must be replaced or grinded as necessary.

>Page 7:10 "Grind the rotating knives".

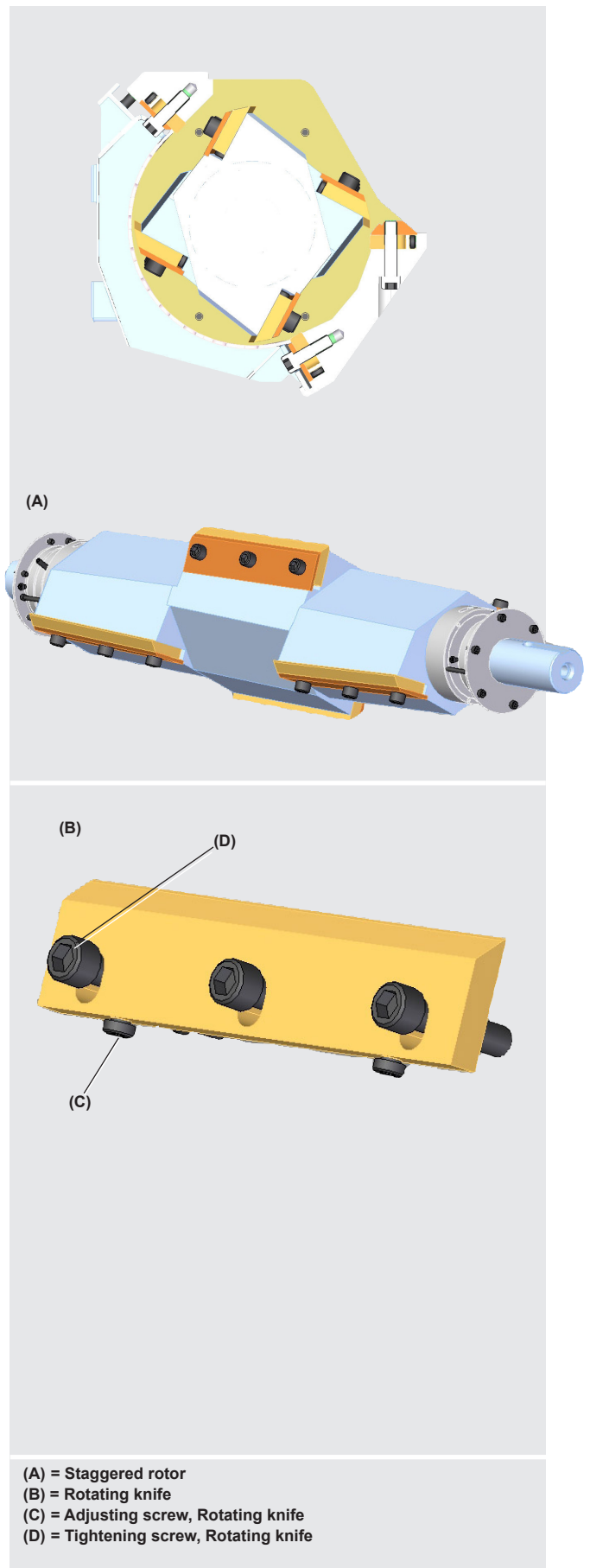

Cutter housing

General rules, Cutter housing

The cutter housing is designed and adapted to the type of plastic residue that the customer has specified before order. The cutter housing can be provided with three fixed knives.

Cutter housing 1st

Cutter housing 1st has a tangential back. Cutter housing 1st has three knife seats: 1st, 5th and 2nd.

Fixed knives

The front fixed knife is installed in the cutter housing's front side. The rear fixed knives are installed in the cutter housing's back side. The fixed knives are fixed with support rules and tightening screws. The knives are provided with adjusting screws which facilitates presetting of the knife clearance. >Page 2:18 "Knife clearance".

The granulator must never be used with blunt knives. Blunt knives cause abnormal wear and damages the granulator. The fixed knives must be replaced, grinded or reversed as necessary. The fixed knives are reversible. This means that the fixed knife has two cutting edges and can be reversed once before grinding or discarding is necessary.

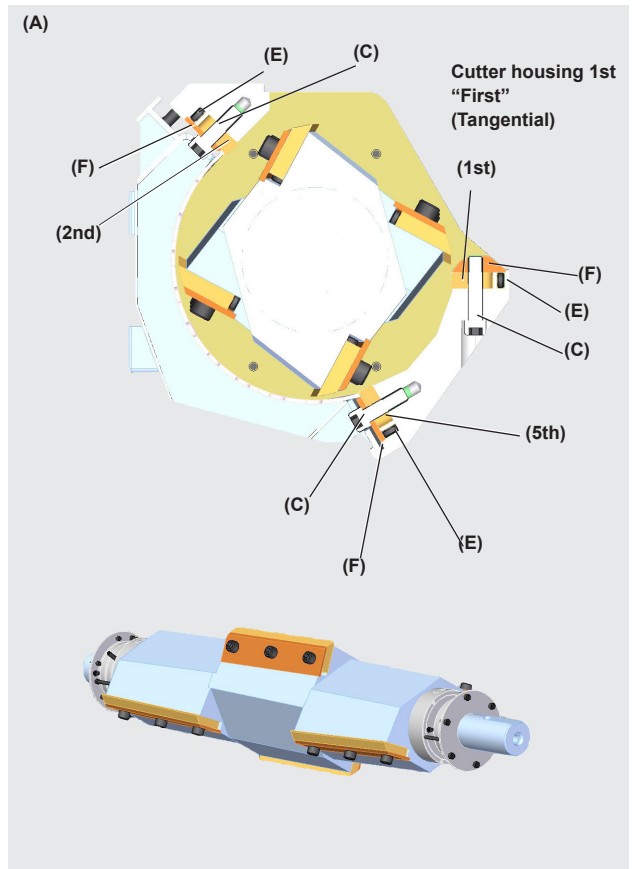

Possible configurations:

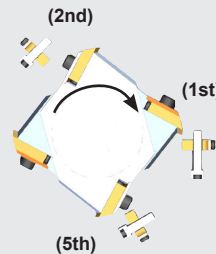

CUTTER HOUSING	FIXED KNIVES
1 st	1st 2nd 5th

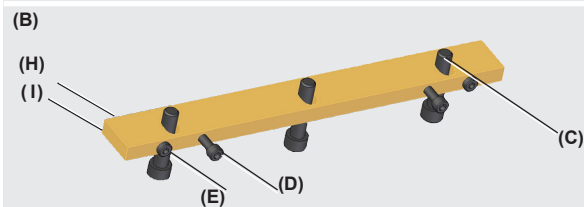

- (A) = Cutter housing 1st
- (B) = Fixed knife
- (C) = Tightening screw, Fixed knife
- (D) = Counter tightening screw
- (E) = Adjusting screw, knife clearance Fixed knife
- (F) = Support rule, Fixed knife
- (H) = Cutting edge No 1, Reversible fixed knife
- (I) = Cutting edge No 2, Reversible fixed knife
- (1st) = Rear fixed knife, 1st
- (2nd) = Front fixed knife, 2nd
- (5th) = Rear fixed knife, 5th

Grinding fixture

The grinding fixture (optional) is used when grinding the knives. The grinding fixture has two knife positions, one adapted for the fixed knife and one adapted for the rotating knife.

>Page 7:9 “General rules, Grind the knives”.

Knife clearance

The knife clearance is the gap between the fixed knife and the rotating knife. Correct knife clearance is 0.10–0.40 mm. The knife clearance is checked with a feeler gauge. >Page 7:13 point 10 “Install the fixed knives”.

The knife clearance is adjusted by tightening / unscrewing the knife’s adjusting screws. The knife clearance is adjusted in a presetting fixture.

>Page 2:18 “Presetting fixture”.

Presetting fixture

The presetting fixture is used when presetting the knives’ adjusting screws.

>Page 7:11 “General rules, Preset the knives”.

Two short presetting fixtures are enclosed on delivery. One is meant for presetting rotating knives and the other is meant for presetting fixed knives.

There is also a long presetting fixture available (optional). The long presetting fixture is convenient as it makes it possible to preset the knife in one step.

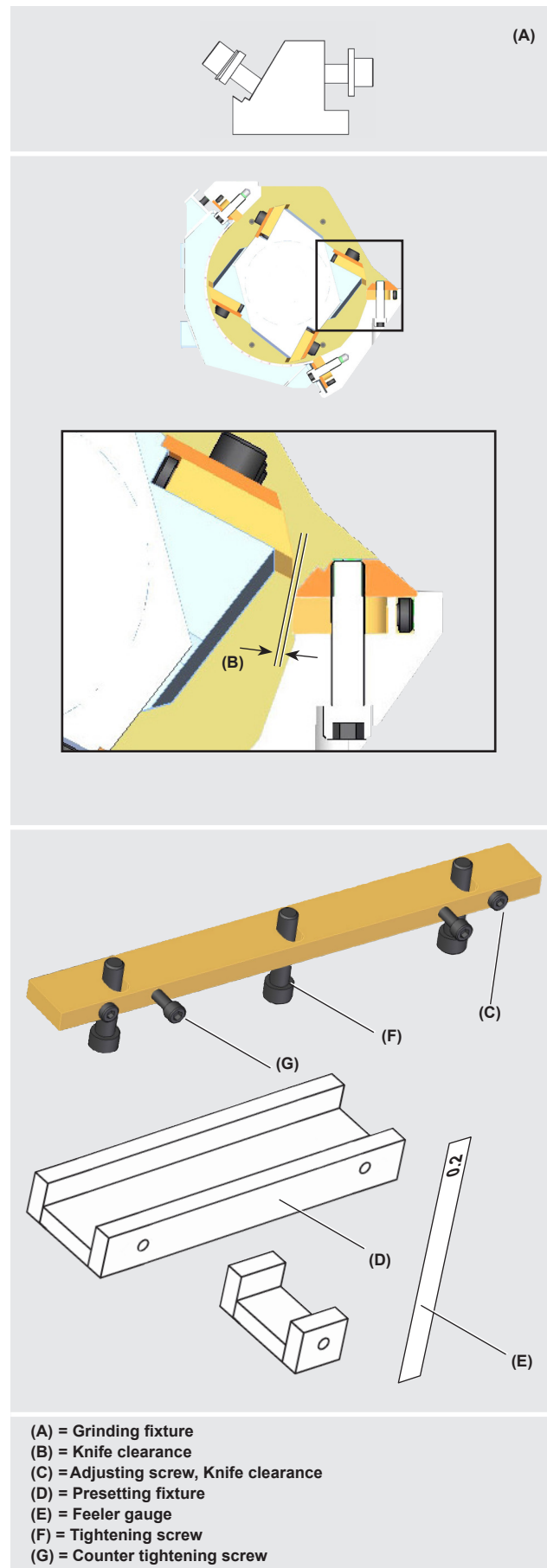

Transmission

Motor

The granulator is driven by an electric motor. The motor is installed on a motor mounting bracket.

Optional motor speed: 1500 rpm (50 Hz) or 1800 rpm (60 Hz).

Optional motor power: 11 kW, 15 kW, 18.5 kW, 22 kW or 30 kW.

Motor power and motor frequency are specified on the motor's machine plate.

Drive belt(s), Motor pulley, Rotor pulley

The granulator is provided with 1 drive belt. The drive belt is tensioned between the motor pulley and the rotor pulley.

The drive belt(s) must be checked regularly. The granulator must not be driven with worn drive belt(s) nor with incorrect belt tension. The belt tension is adjusted by sliding the motor mounting bracket. The belt tension can be checked through the transmission inspection hatch.

>Page 7:15 "Adjust the belt tension".

Flywheel

The granulator can be provided with a flywheel (optional). The flywheel is installed on the opposite side of the rotor pulley. The flywheel optimizes the kinetic energy and makes the granulator even more powerful.

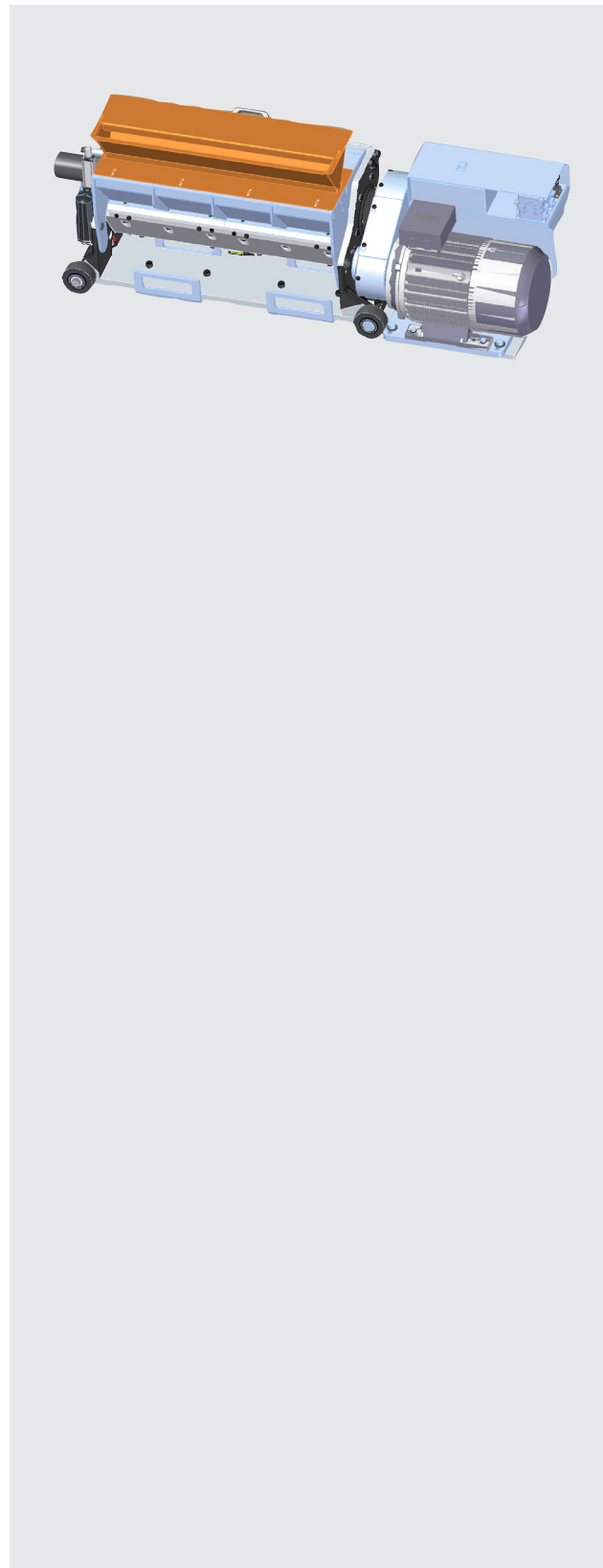

- (A) = Motor
- (B) = Motor mounting bracket
- (C) = Drive belt(s)
- (D) = Motor pulley
- (E) = Rotor pulley
- (F) = Flywheel

Safety equipment



General rules, Safety equipment

Inside the granulator, knives rotate at high speed. For this reason, there is safety equipment which is intended to prevent access to hazardous components during operation.

The safety equipment must not be changed or modified under any circumstances. If any part of the safety equipment is changed or left out, the machine can be dangerous to use.

The safety equipment must be checked regularly. No part of the safety equipment may be replaced by components other than spare parts supplied by Conair.

If any part of the safety equipment is changed or left out, Conair's responsibility under the Machinery Directive ceases to apply.

The safety equipment consists of:

- Hopper
- Inlet / Roller feeder
- Screen
- Screen box
- Granule bin
- Main switch
- Emergency stop
- Stand still monitor
- Safety clamp
- Safety switch
- Safety relay



Note! All these parts must be installed during start and operation.

- In addition, the key for the electrical cabinet, transmission and pneumatic cabinets (if supplied), is part of the safety equipment.

Safety equipment

Inlet

The inlet must be installed during start and operation.

Roller feeder

The granulator can be provided with a roller feeder.
Please read separate instruction manual for Roller feeder.

Screen, Screen box

The screen prevents access to hazardous components during operation. The screen must be installed during start and operation. The screen is installed in the screen box. The screen box must be closed during start and operation. The machine has one or two screens and screen oxes depending on configuration.

The screen is designed and adapted to the type of plastic residue that the customer has specified before order. The screen can easily be changed to give the required granulate size.

Granule bin

The granule bin collects the finished granulate. The granule bin must be closed during start and operation.

The granule bin is designed and adapted to the type of plastic residue that the customer has specified before order.

The granule bin can be provided with a level switch (optional). >Page 2:25 "Level switch".

The granule bin can be provided with a blower (optional). >Page 2:15 "Additional suffix -U".

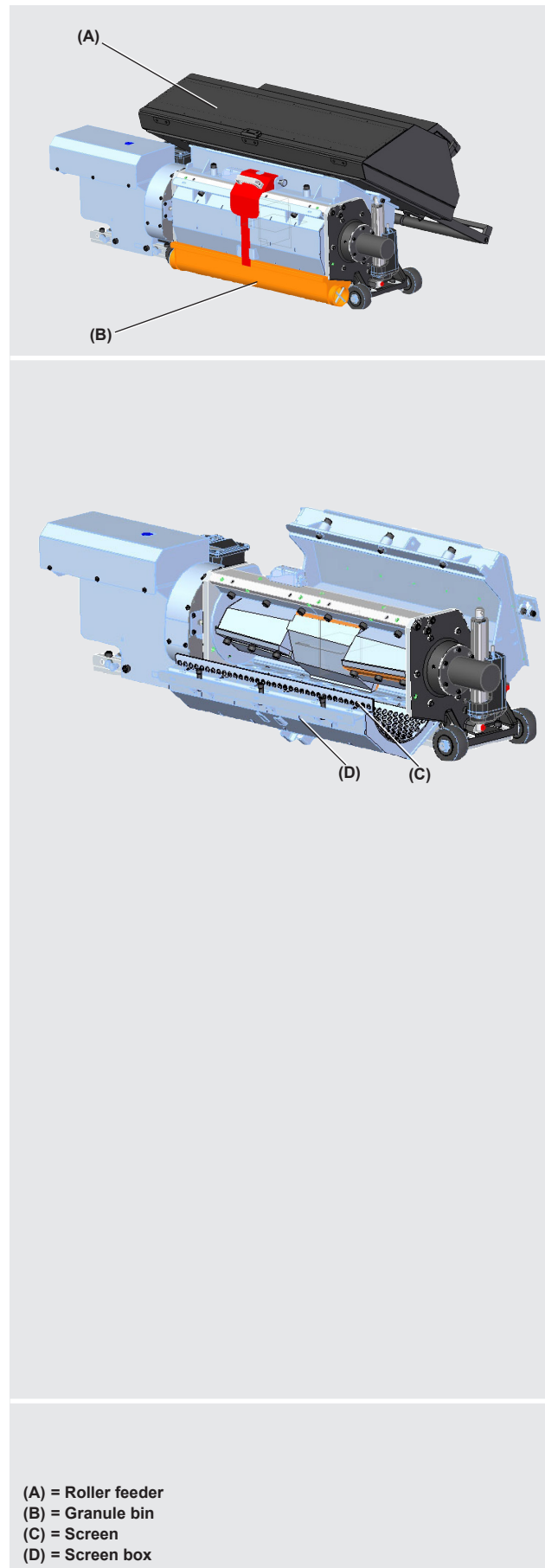

Safety equipment

Main switch

The main switch cuts all 3 phases of the supply voltage. The design and location of the main switch can vary. The granulator's main switch must be locked in position "0" during service.

Emergency stop(s)

The emergency stop stops the machine in case of emergency. The machine can be provided with several emergency stops. The emergency stop(s) must be checked regularly.

The design and location of the emergency stop(s) can vary. The electrical circuit diagram shows the number of emergency stop(s) installed in the supplied machine.

Key to electrical cabinet

All hatches to electrical cabinet, transmission and pneumatics (if supplied) must be closed and locked during start and operation. The key must be kept by the personnel responsible for the machine's service and safety.

Stand still monitor

All CUP granulators are provided with a stand still monitor. The stand still monitor monitors if the rotor is rotating or if it stands still.

The stand still monitor affects the RFID-switch. >Page 2:22 "Safety switch". As long as the rotor is rotating the locking bolt will be locked inside the RFID switch. (This means that it is not possible to open the machine immediately after stopping the machine. After stopping the machine the rotor keeps rotating for some minutes before it slows down and stands completely still.) When the rotor stands still the button "Release safety switch" is lit. Press this button and hold it down. The safety switch starts blinking, this indicate that safety clamp can be removed. Remove the safety clamp and then the machine can be opened.

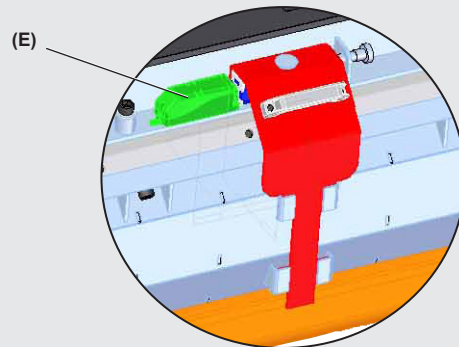
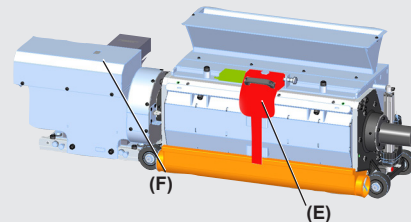
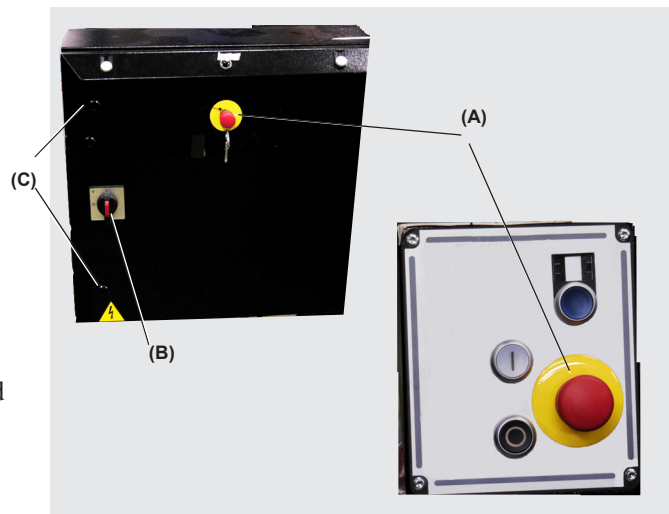

- (A) = Emergency stop
- (B) = Main switch
- (C) = Lock, Electrical cabinet
- (D) = Key to electrical cabinet
- (E) = Safety switch
- (F) = Button, "Release safety switch"

Safety equipment

Safety clamp

The safety clamp make sure that the inlet, cutter housing, screen box and granule bin are closed while the machine is running. The safety clamp contains a key to a safety switch. It is not possible to remove the safety clamp before the granulator stands still. >Page 2:21 “Stand still monitor”.

Safety switch

The machine can be provided with several safety switches which stops the machine when unsafe modes are detected. The safety switch(es) must be checked regularly.

RFID-switch: To be able to start the machine, the locking bolt must be in its extended position inside the RFID carrier

Safety sensor: To be able to start the machine, the two halves must mate up close to each other.

The design and location of safety switches can vary. Examples of where safety switches might be located can be seen in the figure on the right. The electrical circuit diagram shows the number of safety switches installed in the supplied machine.

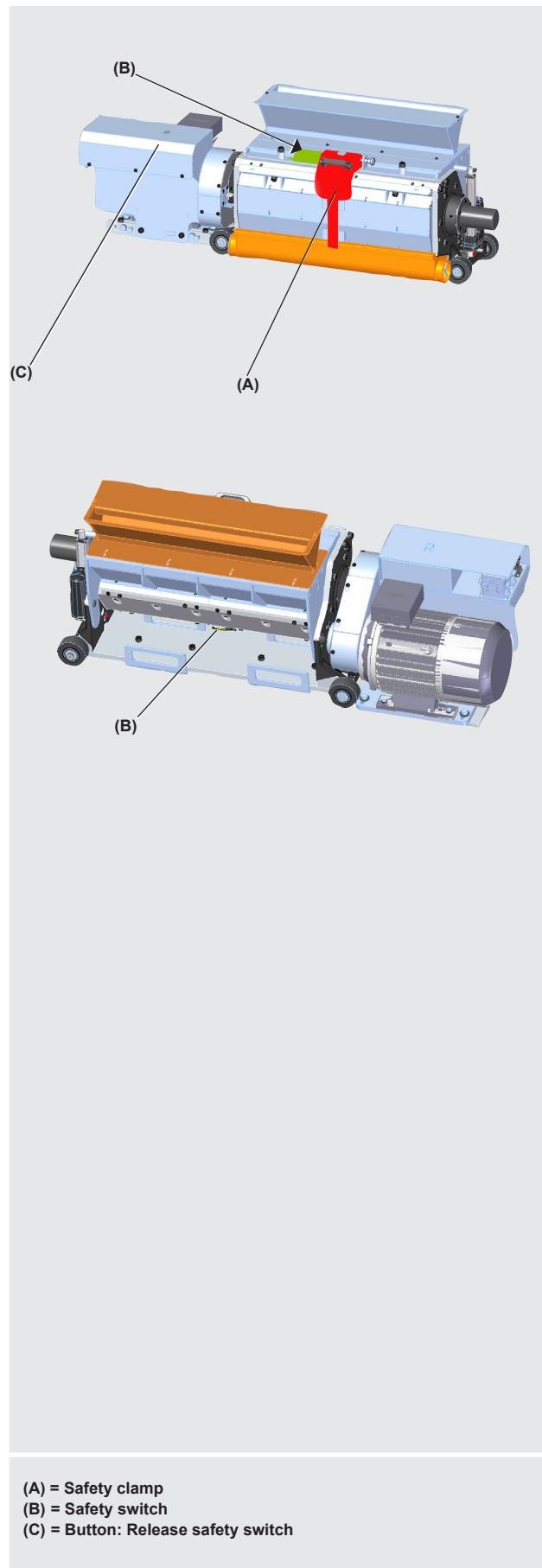

Safety equipment

Safety relay

A CUP granulator is provided with a button “Reset safety relay”. The button “Reset safety relay” is installed on the operating panel. To be able to start the granulator the button “Reset safety relay” must be pressed and lit. >Page 5:1 “Start the granulator” point 5.

If the button “Reset safety relay” do not light up, the safety relay and the safety switches has to be checked.

Overload protection

The machine can be provided with several overload protections. The electrical circuit diagram shows the number of overload protections installed in the supplied machine. The overload protection(s) is(are) installed inside the electrical cabinet.

The overload protection trips if the granulator or any optional equipment is overloaded. Before resetting an overload protection and before restarting the machine, the reason why the overload protection tripped must be determined. Take necessary actions (for example clean the machine) to prevent the overload protection from immediate tripping when restarting the machine.

If the reset knob is in position “0” the overload protection is manually turned off. If the reset knob is in a position between “0” and “1” the overload protection has tripped. The overload protection is reset by turning the reset knob to position “0” and then to “1”.

Operating panel

The machine can be provided with several operating panels. The design and location of the operating panel can vary. The operating panel(s) can be integrated with the electrical cabinet’s hatch and/or detached.

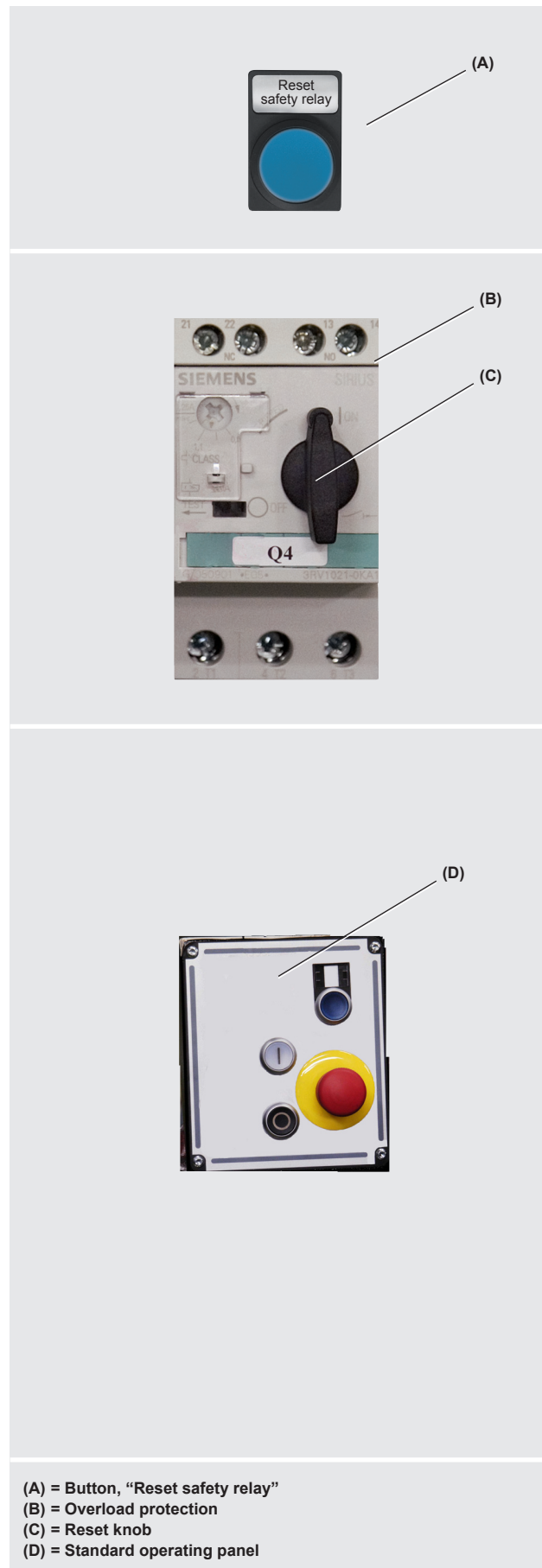

Level switch

General rules, Level switch

The granule bin can be provided with a level switch (optional). The level switch monitors the granulate level in the granule bin. As the granulate level gets too high, the level switch takes one or several of the below listed actions:

- Stops optional feed equipment (such as a band conveyor or a roller feeder).
- Lights up an warning lamp (optional).
- Starts up a siren (optional).
- Stops the granulator and restarts it and/or the feed equipment as the granulate level in the granule bin has sunk (optional).

Level switch, Paddle type

A level switch of paddle type, is provided with rotating paddles. When the granulator is started the paddles starts rotating. If the granulate level gets too high, the paddles will stop rotating. As the paddles stands still, the level switch is activated.

The sensitivity is adjusted by changing the position of the torsion spring. On delivery the tension spring is installed in the second hole from the left. >Page 7:3 point 4 “Level switch”.

Hours counter

The granulator can be provided with an hours counter (optional). The hours counter counts the time the rotor is rotating. The hours counter has no reset.

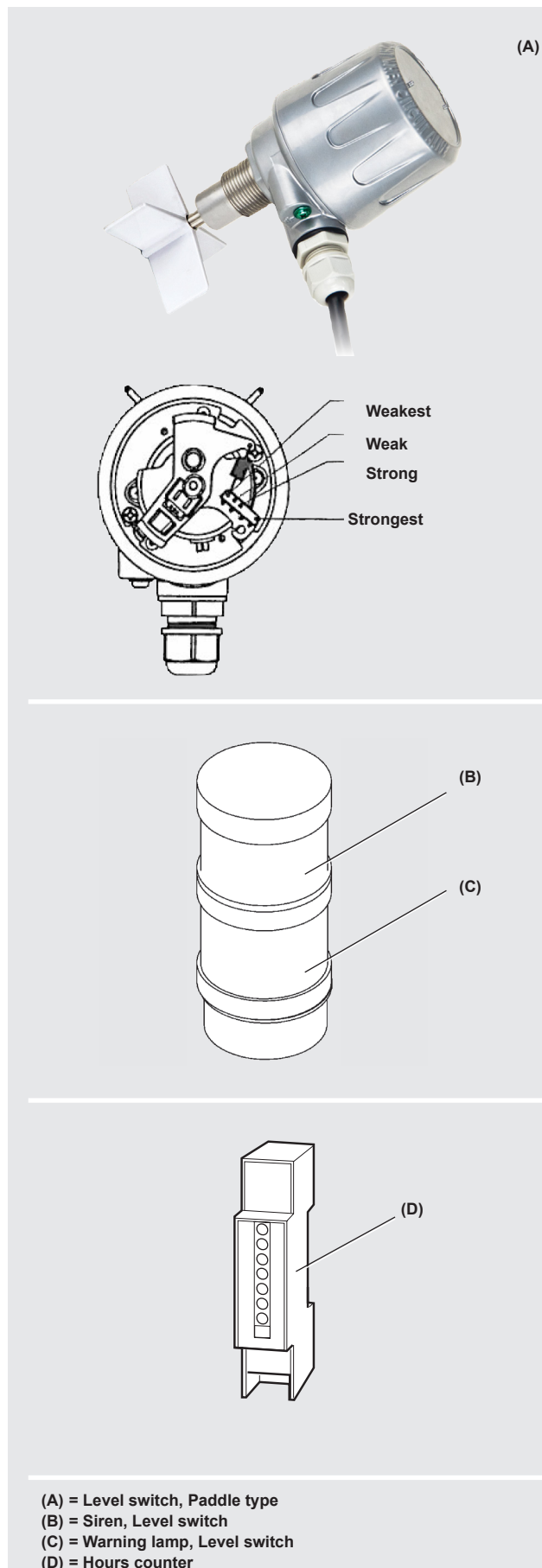

Function settings current relay - overcurrent detector (option)

Application of current relay

When a current relay is installed it is either used to protect the granulator from a too high current level (which can damage the motor) or for detecting when granulator is idle running (detecting idle current level).

When a current relay is used as an overcurrent detector the current relay should detect when the current exceeds the nominal current.

Functions

The functions that are adjustable are:

- Overcurrent detection "Excess current" I^{\wedge}
 - To adjust this function; see next page
- Undercurrent detection - "Under current" I_{\vee}
 - Is not used on Conair's granulators.
 - Should be set to "OFF".
- Delay of detection when a overcurrent detection has occurred: I^{\wedge} Delay (T_1)
 - Is adjustable but is at delivery set to "3.0 s".
- (• Delay of detection when a undercurrent detection has occurred: I_{\vee} Delay
 - It is not possible to adjust if I_{\vee} is set to OFF.
 - Should not be used or adjusted.)
- Delay of detection at startup: onDelay (T_2)
 - Is not used on Conair's granulators.
 - Is set to "0.0 s" and should not be adjusted.
- Memory: "Mem?"
 - Should be set to "No".
 - If "Mem?- Yes", when a detection occur the relay remain in status "detected" until the power is cut. If "Mem? - No", when a detection occur the current level has to decrease (or increase) to a level under (or over) the overcurrent (undercurrent) level to change from status "detected". How much the current level has to decrease (or increase) in relation to the detection value is called hysteresis.
- Hysteresis (HA): "Hyst"
 - To adjust this function; see next page.
- The panel "NC Us=on" should always be set to "NC Us=on". When this panel is changed, the relay works as if all settings were adjusted with the opposite setting.

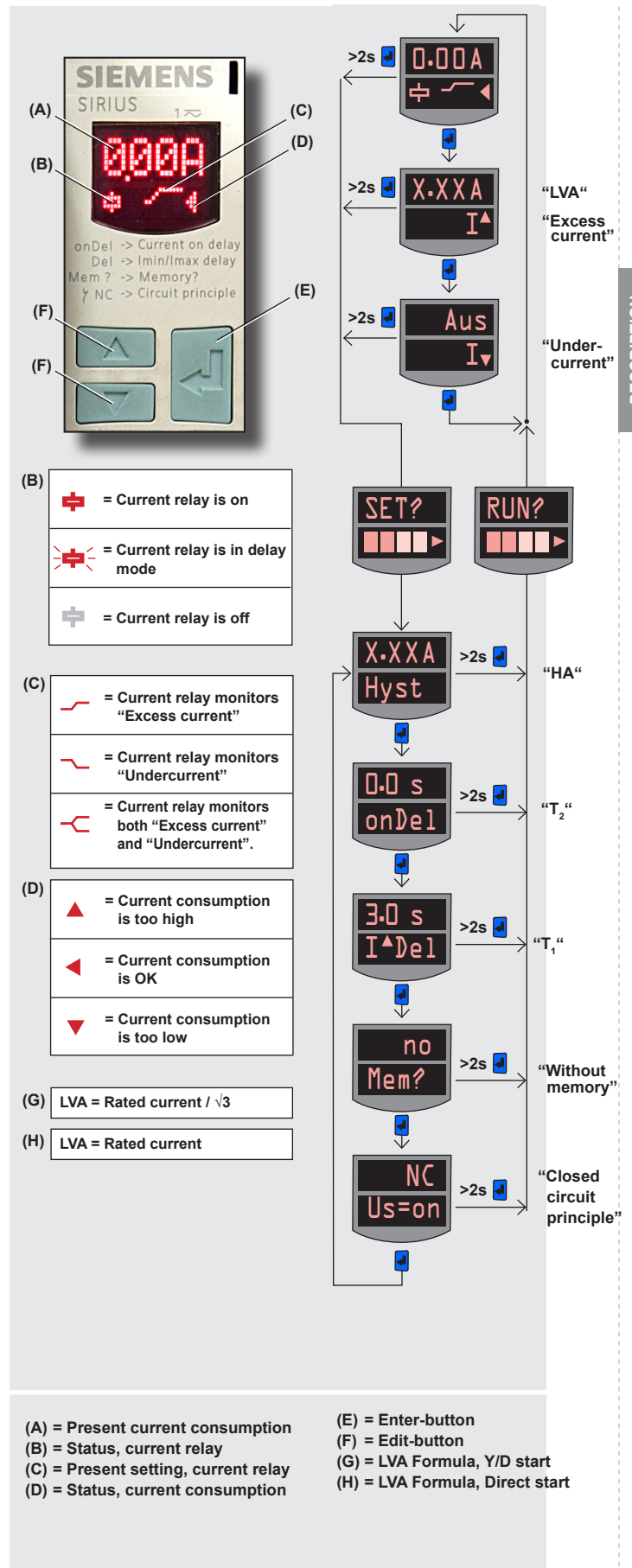

Function settings current relay - overcurrent detector (option)

Parameters that affects overcurrent detection

- Rated current, motor
- LVA (Limit value, Ampere)
 - Is calculated according to formula (G) or (H) depending on if the granulator is Y/D started or Direct started. (G) if granulator is Y/D started and (H) if granulator is direct started or if it is Y/D-started and has a visual ammeter.
 - Overcurrent detection value should be set to LVA-value or slightly lower.
- HA (hysteresis, ampere)
 - Hysteresis (HA) should be set to a value lower then the LVA-value. Around one tenth of the LVA-value.
- The panel “NC Us=on” should always be set to “NC Us=on”.

Check of function settings - overcurrent detection

- Decrease the overcurrent detecting value, I^{\wedge} , to a level lower then idle current level. If the relay detects overcurrent the relay works correctly.
- Increase the overcurrent detecting value, I^{\wedge} , with approximately 12% (if HA is 10% of LVA). If HA is higher than 10% of LVA the overcurrent setting needs to be increase further.

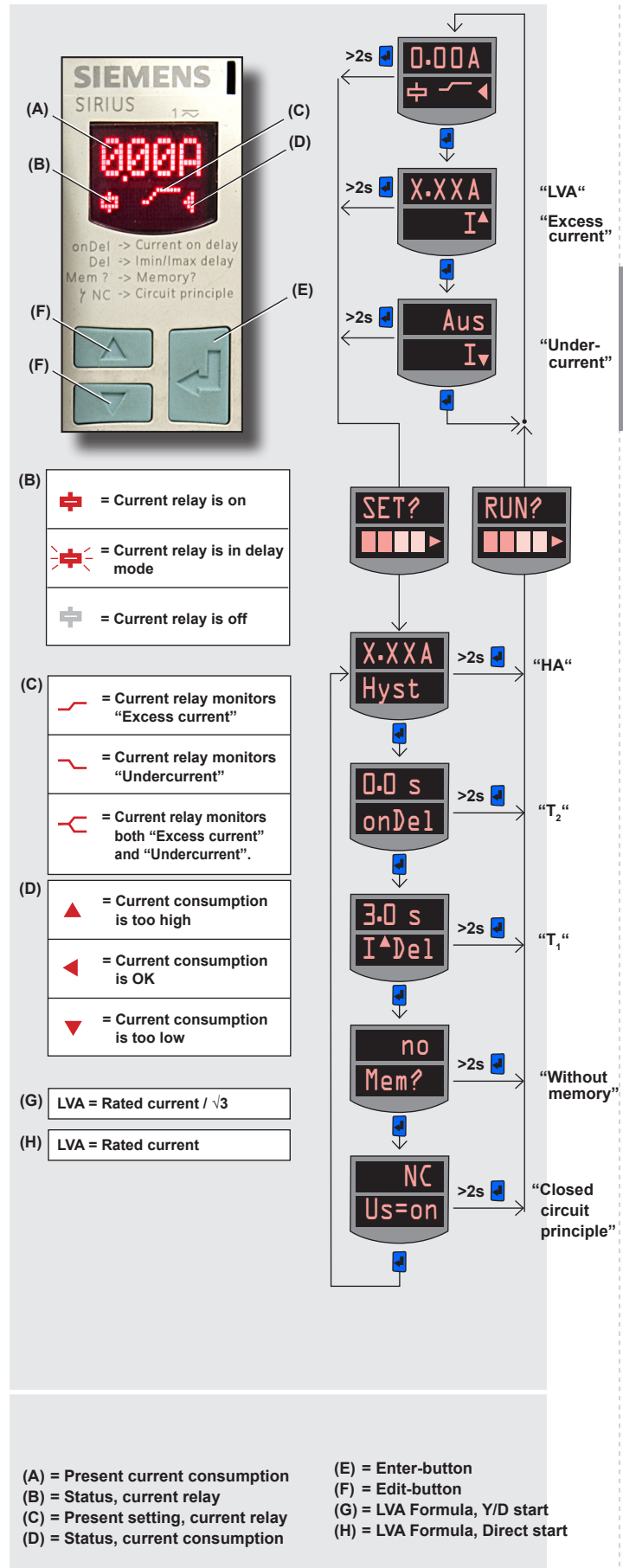
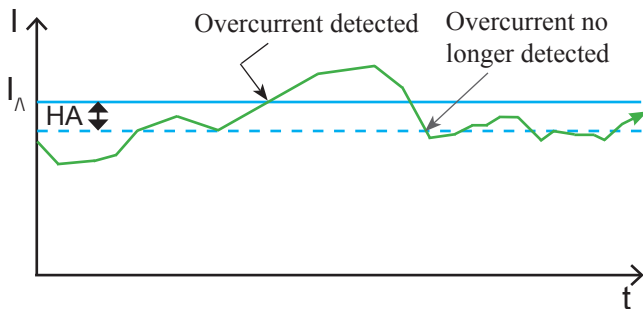

Transport / Lift

General rules, Transport / Lift

The machine must only be transported / lifted by trained personnel. All instructions must be observed to avoid personal injury and machinery damage.

Transport

1. If the machine will be transported exposed to weather and wind: Treat all components that could rust with a rust preventer. Wrap the machine in plastic foil.
2. If the machine will be transported a longer distance or on uneven ground: Fix the machine to a transport pallet with tension straps. Transport / lift the pallet with a fork lift.
3. If the machine will be transported a shorter distance on even, dry ground: Transport the machine with its wheels.

Lift the granulator

1. Open the granulator and remove the granule bin.
>Page 6:2 "Remove the granule bin".
2. Use a fork lift:
Insert the forks as shown in figure on the right. Insert the forks from the backside. Use the marked holes for the forks .
Use lifting strops and lifting beams:
Put lifting beams through the holes for forklift. Put lifting strops on each side of each lifting beam. Make sure that the lifting beam and lifting strop has sufficient capacity to lift the granulator. Make sure that the lifting strops nor the beams will not slip when lifting.
3. Check that no cables or any parts of the safety equipment are pinched when lifting.
4. Lift the granulator. For information about machine weight, refer to page 2:1 "Technical specifications".

Store the granulator

1. Treat all components that could rust with rust preventer for long-term rust protection.
2. Store the machine in a dry area with even temperature.
3. Rotate the rotor manually every 3 months.

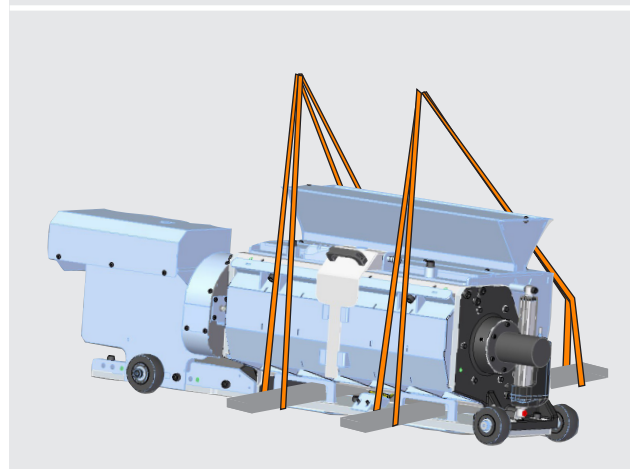
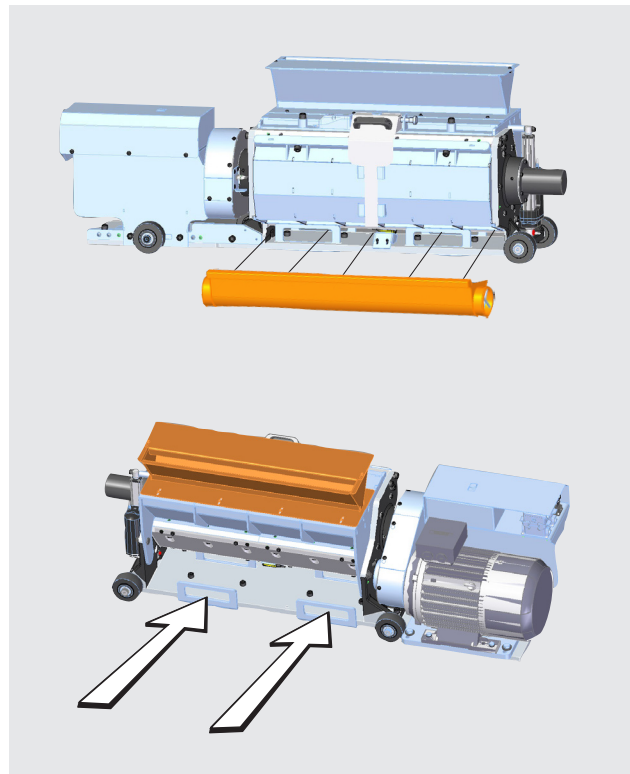

(A) = Remove granule bin before lifting the granulator
(B) = Put forks here
(C) = Lifting with lifting strops and beams

Actions before first start

General rules, Installing

1. Read page 1:2 “Safety rules, During installing”.
2. Read all of chapter 4 before installation is started.
3. Sign the completed installation, in the end of this chapter.

Reception inspection

1. Check the dispatch note to ensure that the delivery is complete.
2. Check that the machine has not been damaged during transport. Any damage must be reported to the forwarding agents.

Put the machine in its working place

1. Refer to layout for required working space.
>Page 2:3 “Layout”.
2. Transport / lift the machine to its working area.
>Page 3:1 “Transport / Lift”.
3. Check that the machine stands horizontal and steady.

Remove the rust preventer

Un-painted components are treated with rust preventer before delivery and transport. Remove the rust preventer before operating the machine.

1. Read page 7:6 “Cleaning”.
2. Clean following parts inside and outside: inlet, granule bin, screen box and screen. Use a low aromatic alkaline degreaser or a gentle solvent. Wipe clean with lint-free rags.

Check the knife clearance

1. Check the knife clearance. >Page 7:13 point 10.

Technical specifications

1. Fill in correct information on page 2:1 “General data, Supplied machine” so that the data corresponds with the machine sign on your supplied machine.
2. Mark the correct alternatives on page 2:1 “General data, Conair CUP-series” so that the data corresponds with your supplied machine.
3. Sign the personnel responsible for the machine’s service and safety on page 2:1.

Actions before first start



General rules, Electrical connection

1. Read page 4:1 “General rules, Installing”.
2. The machine must be disconnected from the mains before electrical repairs or installing is began.
3. The machine must be installed in accordance to EN 13849-1 Category 3. This means that all cables must be installed so that they will not get damaged during operation.
4. All electrical service, must be done by authorized, trained personnel. No modifications or alterations of the basic electrical settings are permissible unless a written approval has been obtained from Conair’s head office. Refer to the separate electrical circuit diagram.
5. When replacing electrical components, only use original spare parts supplied by Conair.

Emergency stop

1. Read page 4:2 “General rules, Electrical connection”.
2. Check that the supplied emergency stop is within reach at all positions in the machine’s workplace.
3. If the supplied emergency stop is not accessible from all positions in the workplace, the machine must be provided with further emergency stops.
In event of any questions, please contact Conair’s local distributor or Conair’s head office.

Level switch (optional)

1. Check that the level switch’s setting is satisfying.
Adjust as necessary. >Page 7:3.

Current relay (optional)

1. Check that the current relay’s setting is satisfying.
Adjust as necessary. >Page 7:4.

Connect the granulator to the mains

1. Read page 4:2 “General rules, Electrical connection”.
2. Check the phase sequence of the electric mains with a phase sequence display. The granulator is connected for a right-hand turning field. The electric circuit diagram specifies the connection voltage (Volt) and fuse size (Ampere).
3. Connect the granulator to the mains.

Start the granulator

1. Check that all actions in page 4:1–4:2 are done.
2. Check that all parts of the safety equipment are installed. >Page 2:19.
3. Close the granulator. >Page 6:4.
4. Start the granulator. >Page 5:1.

Checks immediately after first start

1. Check that the rotating direction of the granulator's Motor corresponds to the arrow on the motor.
2. Additional suffix -U (Blower):
 - Check that the blower's rotating direction corresponds to the arrow on the blower. The blower is functioning even when the rotation direction is wrong, but if the blower's rotating direction is wrong the blower's capacity decreases considerably.
3. If the rotating direction is wrong:
 - a) Stop the granulator. >Page 5:1.
 - b) Read page 4:2 "General rules, Electrical connection".
 - c) Switch over two incoming phases.
 - d) Start the granulator. >Page 5:1.
4. Check the emergency stop(s). >Page 7:1.
5. Check the safety equipment. >Page 7:2.
6. Check the knife clearance. >Page 7:13 point 10.



Checks 30 hours after first start

1. Stop the granulator. >Page 5:1.
2. Check the knife clearance. >Page 7:13 point 10.
3. Check the drive belt(s). >Page 7:15.
4. Check the tightening torque of important machine parts. >Page 7:5.

Installing complete

The machine has been installed and checked in accordance with the instructions in chapter 4.

Date: / 20

Name:.....

Start the granulator

1. Read page 1:2 "Safety rules, During start and operation".
2. Check that there is no material in inlet or cutter housing.



Important! The granulator must not be started if there is material left in the hopper and cutter housing. When starting, remaining material may overload the motor. The overload protection will trip and the granulator will stop.

3. Put the main switch in position "1".
4. Reset the emergency stop(s).
5. Press the button "Reset safety relay".

When the button "Reset safety relay" has lit up, the granulator is ready to be started.

If the button "Reset safety relay" do not light up, the safety relay has to be checked. >Page 7:3.

6. Start the granulator. Press the start-button.
7. When the start-button has lit up, the granulator is started and ready for operation.

Information! If the granulator or optional equipment does not start once the above points have been attended to, read page 7:17 "Fault tracing".



Stop the granulator

1. Stop feeding material. Wait until all material have been fully granulated.

Important! Never stop the granulator until all material in inlet and cutter housing have been fully granulated.

Important! A granulator with blower must not be stopped until all material have been transported out of the granule bin and the blower.



2. Stop the granulator. Press the stop-button.
3. Press the emergency stop(s).



4. Lock the main switch in position "0".
5. The granulator is stopped.

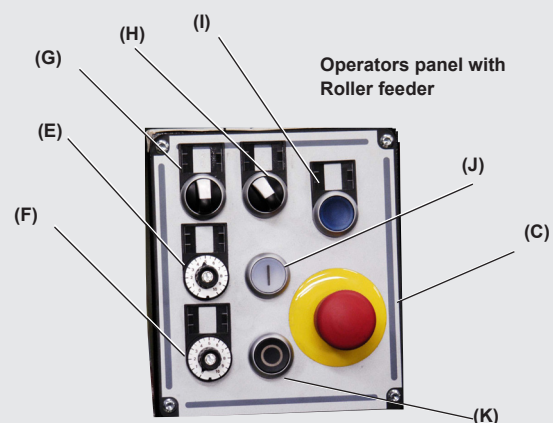
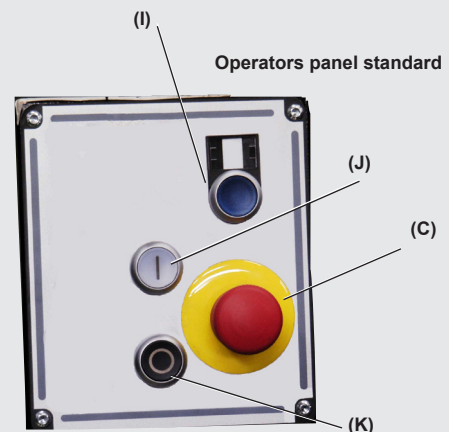
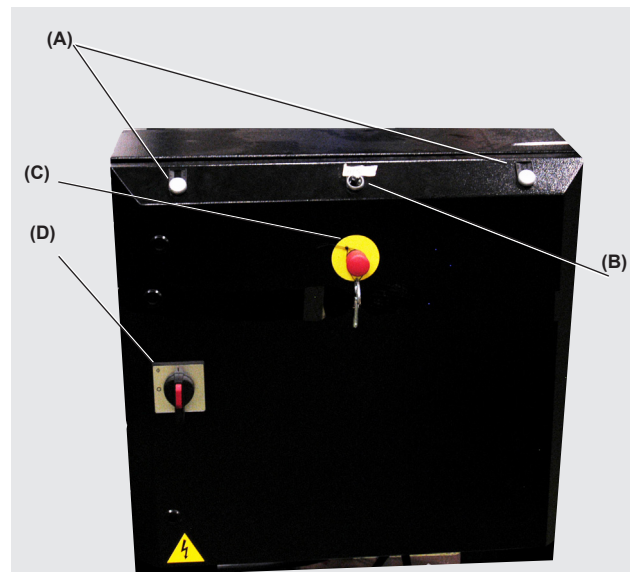

- (A) = Operate 1, & 2
- (B) = Hopper open/close
- (C) = Emergency stop
- (D) = Main switch
- (E) = Potentiometer Roller speed, internal
- (F) = Potentiometer Roller speed, external
- (G) = Roller feeder Internal Start/0/External Start
- (H) = Rollers Close/Open
- (I) = Button, Reset safety relay
- (J) = Start-button
- (K) = Stop-button

Start the roller feeder



Information! Normally, the roller feeder is delivered integrated with a granulator. For this reason, both the roller feeder's instruction manual and the granulator's instruction manual must be carefully observed, before installing, operating or maintaining the machine.

1. Read page 1:2 "Safety rules, During start and operation" in the Roller Feeder manual.
2. Read page 2:3 "Additional functions" in the Roller Feeder manual.
3. Put the main switch in position "1".
4. Reset the emergency stop(s).
5. Check that there is no material in hopper or cutter housing.
6. Start the connected granulator. Read page 5:1
7. Before starting:
 - a) Additional function RPP:
Close the gap between the rollers. Put the knob "Rollers, Open / Close" in position "Close".
8. Start the roller feeder:
 - a) Put the knob "Off / On" in position "On".
or
Additional function Internal and external start:
Put the knob "Internal start / 0 / External start" in position "Internal start" or "External start".
9. The granulator and the roller feeder are started.



Information! If the roller feeder does not start once the above points have been attended to, read page 7:8 "Fault tracing".

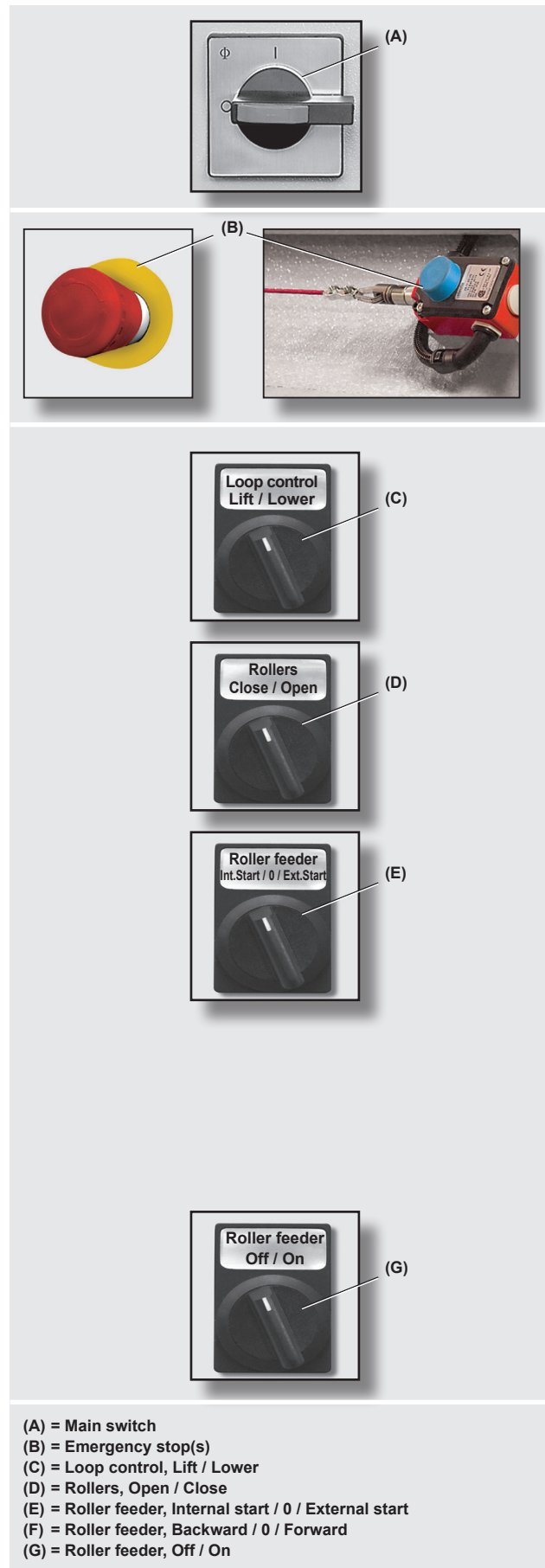

- (A) = Main switch
 (B) = Emergency stop(s)
 (C) = Loop control, Lift / Lower
 (D) = Rollers, Open / Close
 (E) = Roller feeder, Internal start / 0 / External start
 (F) = Roller feeder, Backward / 0 / Forward
 (G) = Roller feeder, Off / On

Start the roller feeder

Adjust the roller speed

1. Read page 2:4 “Adjustable roller speed” in the Roller Feeder manual.
2. Adjust the roller speed with the potentiometer.



Important! Roller speed must only be adjusted when the roller feeder is started.



Information! The roller speed affects the quality of the granulate. >Page 2:2 point 3 “High roller speed” and “Low roller speed” in the Roller Feeder manual.

Start feeding

1. Start the roller feeder. >Page 5:2.
2. Reduce the roller speed to a very low speed.
3. Adjust the inlet’s guide pins, so that the plastic foil is fed straight into the roller feeder’s inlet.
4. Additional suffix -K (Enclosure): Open the hatch, so that the inlet becomes visible.
5. Additional function CLF / CLP: Thread the plastic foil, under the loop control’s drum.
6. Carefully thread the plastic foil, into the roller feeder’s inlet. Let the rollers grasp the plastic foil.
7. Increase the roller speed. Let the rollers run slightly faster than the incoming plastic foil.
5. Close the hatch (if available).
6. The roller feeder is fed.



Information! If the feeding fails, once the above points have been attended to, read page 7:8 “Fault tracing” in the Roller Feeder manual.



Information! The roller speed must be checked regularly.

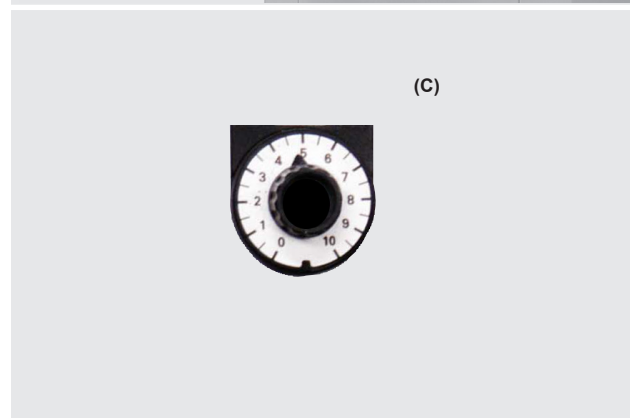
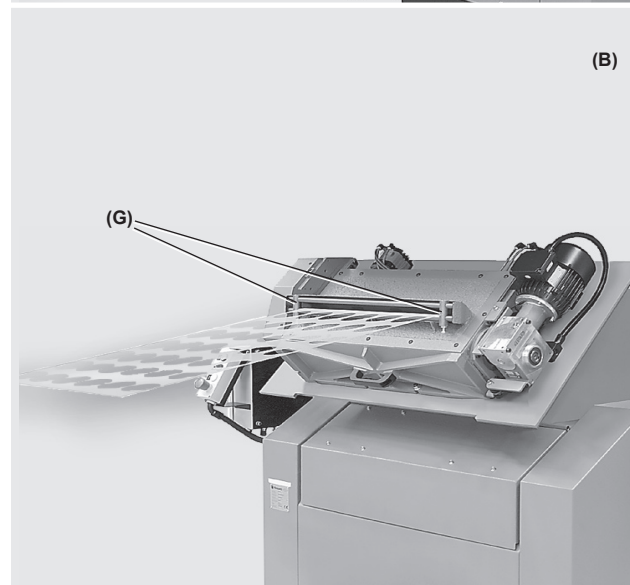
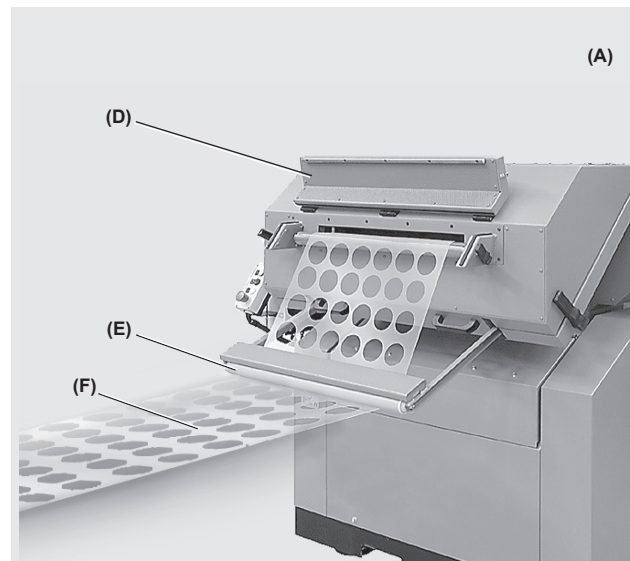

- (A) = Roller feeder with enclosure and with loop control
 (B) = Roller feeder without enclosure and without loop control
 (C) = Potentiometer
 (D) = Hatch, Enclosure
 (E) = Drum, Loop control
 (F) = Plastic foil
 (G) = Guide pins

Stop the roller feeder

1. Stop feeding material. Wait until all material have been fully granulated.
2. Stop the roller feeder.
 - a) Put the knob "Off / On" in position "Off".
or
 - a) Additional function Internal start / External start: Put the knob "Internal start / 0 / External start" in position "0".
3. Stop the connected granulator. Refer to the granulator's instruction manual.
4. Press the emergency stop(s).
5. Lock the main switch in position "0".
6. The granulator and the roller feeder are stopped.

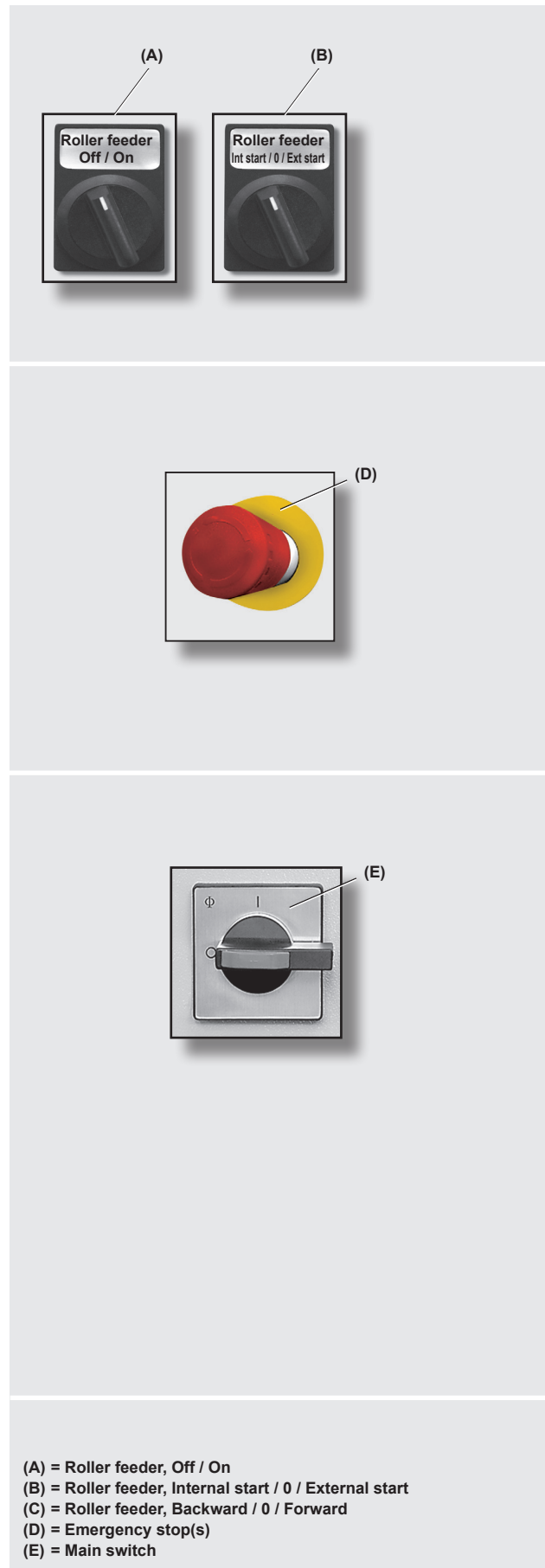

Open the granulator

General rules, Open the granulator

1. Read page 1:3 "Safety rules, During service".

Open the transmission inspection hatch

1. Read page 6:1 "General rules, Open the granulator".
2. Open the transmission inspection hatch. Unscrew the transmission inspection hatch's tightening screws.
3. The transmission is available for inspection.

Open the transmission

The transmission doesn't need to be opened for inspection or adjustment of the drive belt. The belt tension can be checked through the transmission inspection hatch, Read page 6:1 "Open the transmission inspection hatch". The belt tension can be adjusted without opening the transmission, Read page 7:15 "Adjust the belt tension". If additional service is required, contact local distributor or head office.

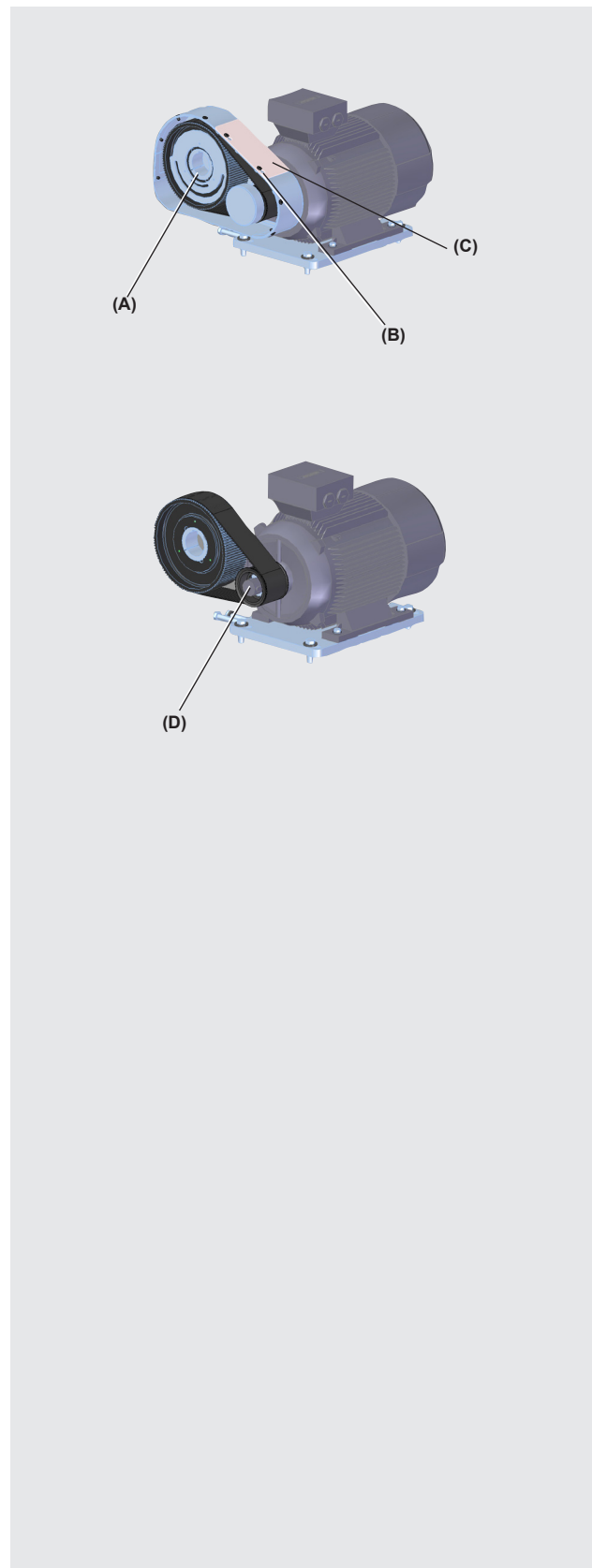

- (A) = Rotor pulley
 (B) = Tightening screws transmission inspection hatch
 (C) = Transmission inspection hatch
 (D) = Motor pulley

Open the granulator

Remove the safety clamp

1. Read page 6:1 “General rules, Open the granulator”.
2. When the granulator stands still the button “Release safety switch” is lit. Press this button and hold it down. The safety switch starts blinking, this indicate that safety clamp can be removed. >Page 2:22 “Safety clamp”. See figures to the right.
3. Remove the safety clamp
4. The safety clamp is removed.

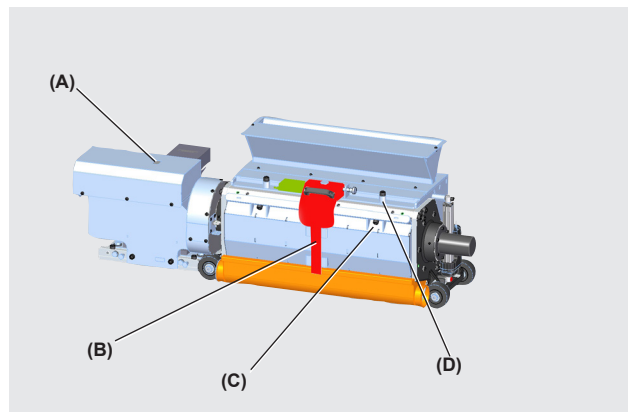

Remove the granule bin

1. Remove the safety clamp. >Page 6:2.
2. Remove the granule bin’s quick coupling ring.
3. Remove the granule bin. Move the granule bin along the grooves in the screen box outer lower edge
4. The granule bin is removed

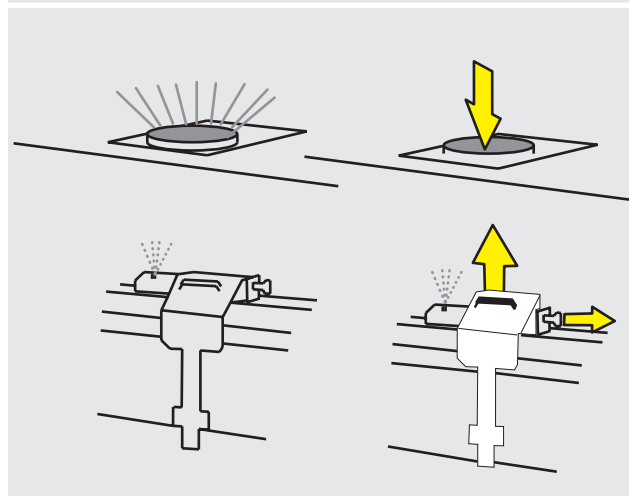

Open the Screen box

1. Remove the safety clamp. >Page 6:2.
2. Remove the granule bin. > Page 6:2
3. Unscrew all screws to the screen box except one screw in the middle. see figure to the right.
4. Carefully unscrew the last screw while supporting the screen box by hand, as the screen box will drop when the last screw is removed.
4. Fold down the screen box.
5. Remove the screen
6. The Screen box is open.

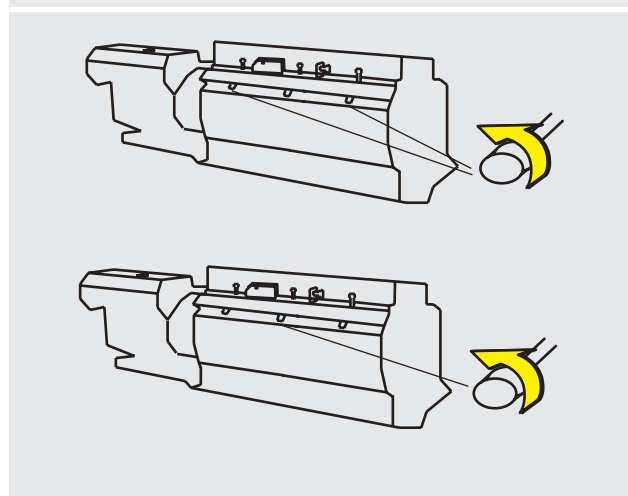
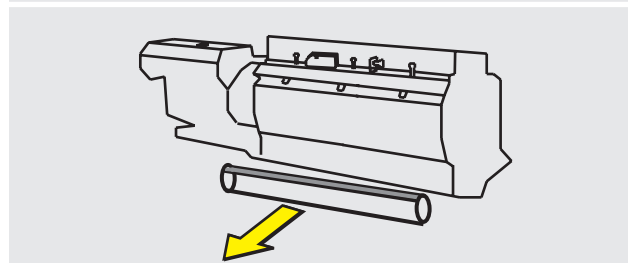

- (A) = Button “Release safety switch”
 (B) = Safety clamp
 (C) = Screws to Screen box
 (D) = Screws to hopper

Open the granulator

Open the Hopper

1. Remove the safety clamp. >Page 6:2.
2. Unscrew the screws holding the hopper in place. See figure to the right.
3. Put the Hopper Open/Close switch on "Open". The switch is located on the electrical cabinet.
4.
 - a) Check that the buttons "Operate 1" and "Operate 2" are lit. (The button "Operate 1" is lit when the rotor stands still. The button "Operate 2" is lit when the cutter housing is unlocked.)
 - b) At the same time (two hand operation), press the buttons "Operate 1" and "Operate 2". Keep the buttons depressed until the jack has opened the hopper.
5. The hopper is opened.

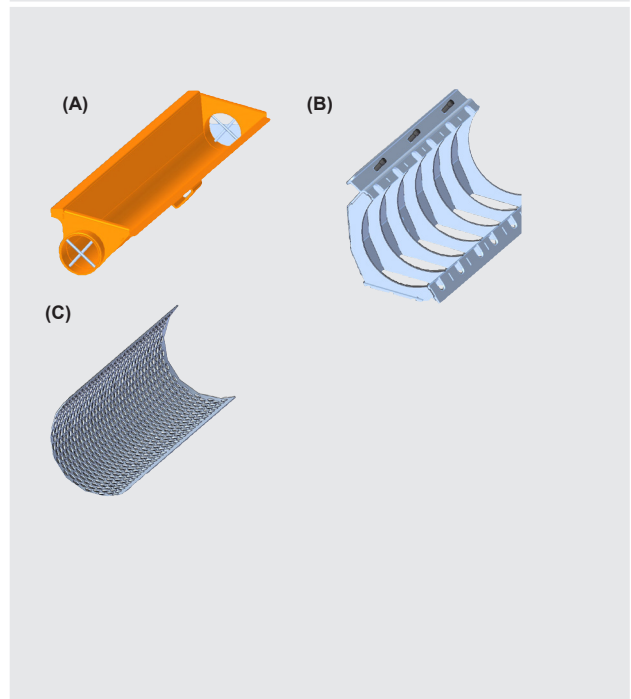
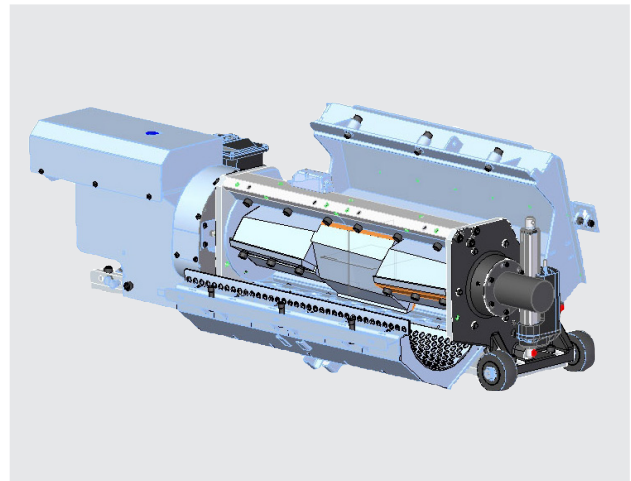
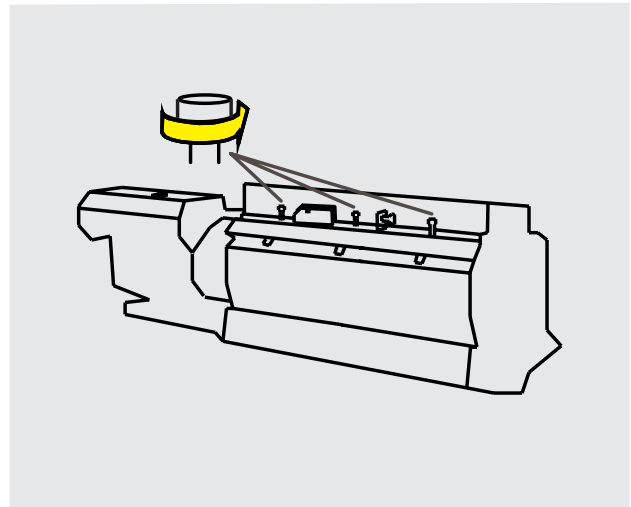

(A) = Granule bin
 (B) = Screen box
 (C) = Screen

Close the granulator

General rules, Close the granulator

1. Read page 1:3 "Safety rules, During service".
2. Check that all surfaces which are going to touch are clean before closing.

Close the hopper

1. Read page 6:4 "General rules, Close the granulator.
2. Close the hopper
 - a) Put the Hopper Open/Close switch on "Close". The switch is located on the electrical cabinet.
 - b) Check that the buttons "Operate 1" and "Operate 2" is lit. (The button "Operate 1" is lit when the rotor stands still. The button "Operate 2" is lit when the cutter housing is unlocked.)
 - c) At the same time (two hand operation), press the buttons "Operate 1" and "Operate 2". Keep the buttons depressed until the jack has closed the hopper.
3. The hopper is closed.

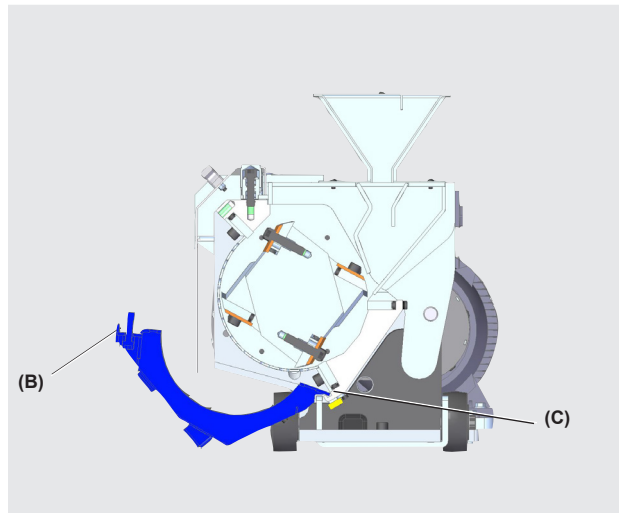
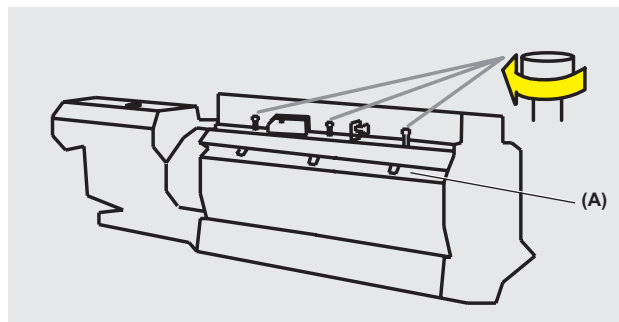

Close the screen box

1. Read page 6:4 "General rules, Close the granulator.
2. Put the screen box in place by mounting the edge of the screen box in the grooves underneath the fixed knife
3. Put the screen in the screen box and close carefully by folding it upwards.
4. Tighten the bolts holding the screen box in place.
5. The screen box is closed.

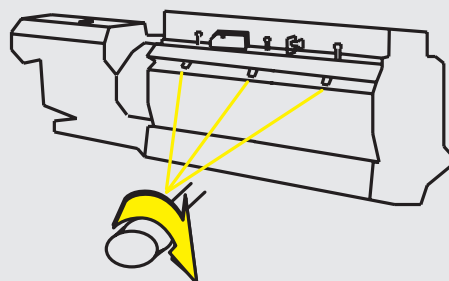

Close the transmission inspection hatch

1. Read page 6:4 "General rules, Close the granulator".
2. Close the transmission inspection hatch. Tighten the inspection hatch's tightening screw.
3. The transmission inspection hatch is closed.

(A) = Bolts holding the hopper in place
 (B) = Screen's upper border
 (C) = Screen's lower border, correctly installed in the grooves

Close the granulator

Install the granule bin

1. Read page 6:4 “General rules, Close the granulator”.
2. Close the screen box. >Page 6:4
3. Install the granule bin. Move the granule bin along the grooves in the screen box lower part
4. Check that the granule bin’s safety switch has mated with the other half on the stand.
>Page 2:22 “Safety switch”.
5. Install the granule bin’s quick coupling ring.
>Page 6:4 image (A).
6. The granule bin is closed.

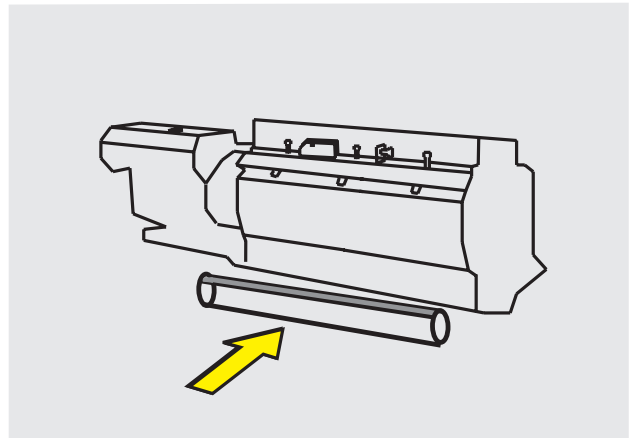

Mount the safety clamp

1. Read page 6:4 “General rules, Close the granulator”.
2. Close the hopper. >Page 6:4.
3. Close the screen box. >Page 6:4
4. Close the granule bin. >Page 6:4.
5. Insert the safety clamp. The safety switch will automatically lock.
6. The safety switch goes from blinking to a steady green light.
7. The safety clamp is mounted.



General rules, Service



1. Read page 1:3 "Safety rules, During service".
2. Check / maintain the machine in accordance with the service schedule.
3. Always sign inspections / service in a service report. Copy the original service report, sign it and save it in a separate service binder. >Page 8:1 "Service report".

Emergency stop(s)

1. Read page 7:1 "General rules, Service".
2. Read page 2:21 "Emergency stop(s)". Check the emergency stop(s):
 - a) Start the granulator. >Page 5:1.
 - b) Stop feeding material. Wait until all material have been fully granulated.
 - c) Press the emergency stop. Check that the granulator stops. If the granulator stops, the emergency stop can be reset and the granulator can be restarted.
 - d) **Danger!** If the granulator continues working, although the emergency stop has been pressed, the granulator must be stopped manually at once. >Page 5:1. There is a serious risk of personal injury! Contact the personnel responsible for the machine's service and safety.



Lubrication

When the rotor bearing housings are equipped with grease nipples, the bearings needs re-lubrication, see also separate instruction. Re-lubrication must only be applied when advised by Conair Contact the Conair headquarters for further information.

If the rotor bearing housings do not have grease nipples (standard) the rotor bearings are lubricated for life and do not need re-lubrication.

Service schedule

Interval	Done by	Check
Once every day	Operator	• Emergency stop(s)
Once every week	Trained personnel	• Electrical components • Safety equipment • Safety relay
Once every month	Trained personnel	• Knife sharpness • Knife clearance • Screen
Once every 6th month	Trained personnel	• Drive belt(s) • Important tightening torques

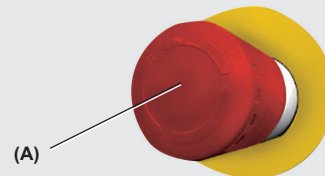

(A) = Emergency stop(s)

Safety equipment

1. Read page 7:1 “General rules, Service”.
2. Read page 2:19 “General rules, Safety equipment”.
Check that all parts of the safety equipment are installed.
3. It is not possible to start the machine if the locking bolt in the RFID switch is not in its extended position in the RFID carrier. When attempting to lock, three tries are made and then the Main switch need to be turned off for 5 seconds and then turned on again. Switch B (refer figure on the right) has got a signal showing:
 - *Blinking Green* = Attempt to lock
 - *Steady Green* = Locked
 - *Blinking Red* = Unlocked position during attempt to lock.
 - *Steady Red* = Locking attempt failed after three tries. No more attempt will be made until main switch is turned off for 5 secs and then turned on again.

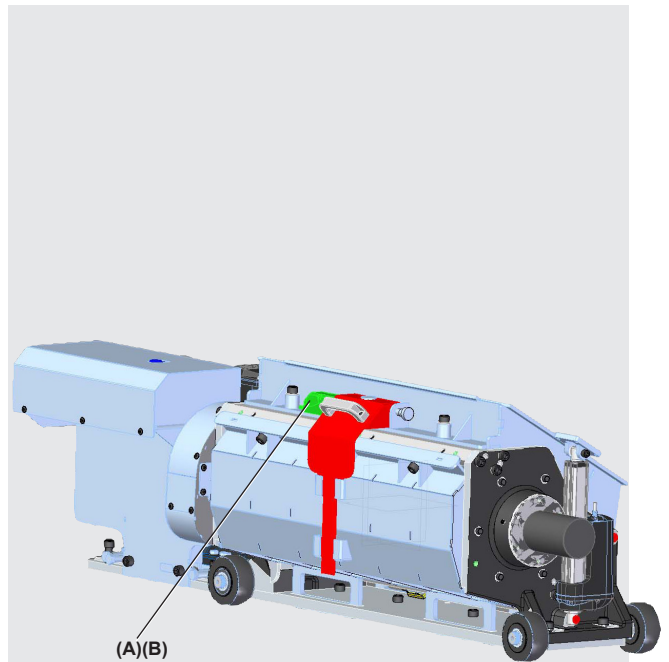

Electrical components

1. Read page 7:1 “General rules, Service”.
2. Read page 4:2 “General rules, Electrical connection”
3. Check all the cables. If there are any damaged or loose cables, connectors or components, authorised personnel must be called at once to do repairs.

(A) = Safety Switch
(B) = RFID switch

Safety relay

1. Read page 7:1 “General rules, Service”.
2. Read page 2:23 “ Reset safety relay”.
3. Reset the emergency stop(s).
4. Check that the main switch is in position “1”.



Danger! Do not put the main switch in position “0”. (When the main switch is put in position “0”, the button ”Reset safety relay” resets, but a possible failure remains).

5. Press the button “Reset safety relay”.
6. Check that the button “Reset safety relay” is lit.
If the button “Reset safety relay” lights up, the safety relay is functioning and the granulator can be started.



Danger! If the button “Reset safety relay” do not light up, this indicates a safety failure. There is a serious risk of personal injury! Contact the personnel responsible for the machine’s service and safety.

Level switch

1. Read page 7:1 “General rules, Service”.
2. Read page 2:24 “Level switch”.
3. Remove the granule bin. >Page 6:2.
4. Adjust the level switch’s sensitivity.

Level switch, Paddle type:

- a) Unscrew the level switch’s cover.
- b) Adjust the tension spring. Use a pair of needle nosed pliers or a tweezers.



To decrease the sensitivity – Move the tension spring to the left, towards “weakest”.

To increase the sensitivity – Move the tension spring to the right, towards “strongest”.

- c) Close the level switch’s cover.
5. Close the granule bin. >Page 6:4.

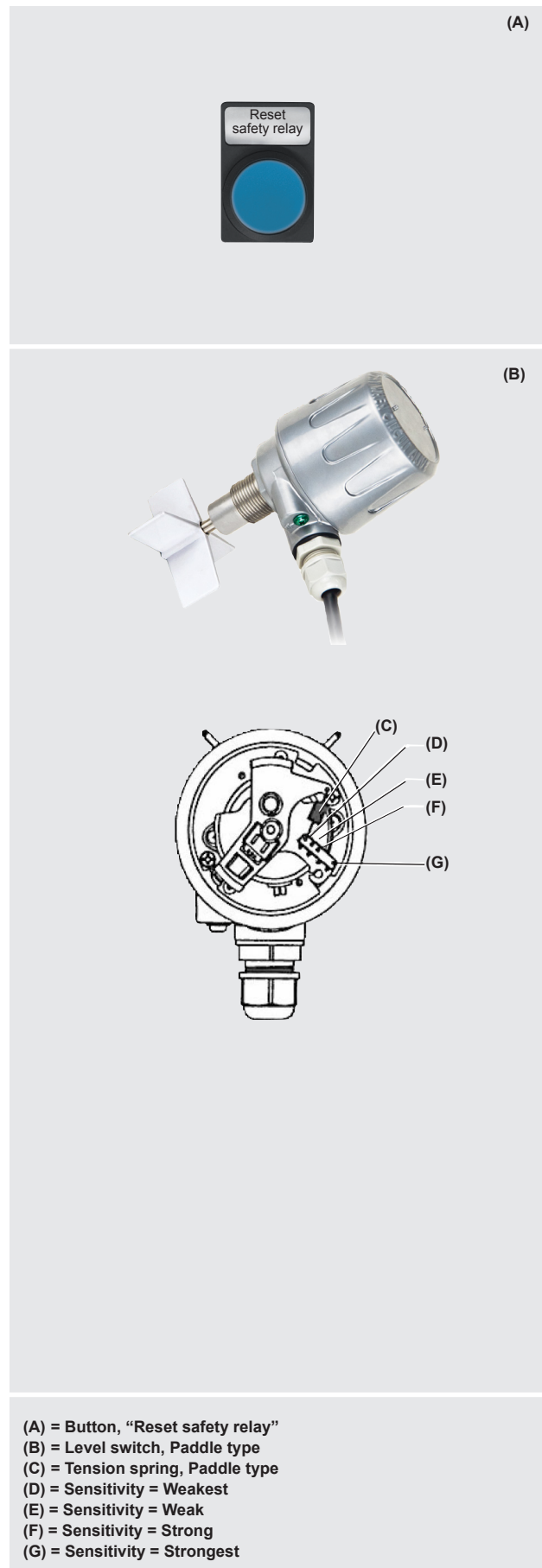

- (A) = Button, “Reset safety relay”
 (B) = Level switch, Paddle type
 (C) = Tension spring, Paddle type
 (D) = Sensitivity = Weakest
 (E) = Sensitivity = Weak
 (F) = Sensitivity = Strong
 (G) = Sensitivity = Strongest

Current relay

1. Read page 7:1 “General rules, Service”.
2. Read page 2:25-2:26 “Current relay”.
3. Set the wanted reaction time: I^ΔDelay (T₁).
4. Set the time delay during start up, OnDelay (T₂), to 0 sec.
5. Check following points in the electrical circuit diagram:
 - Rated current.
 - Y/D-start or Direct-start. If the granulator is Y/D started and equipped with an ammeter, calculate as if granulator is direct started.
6. Calculate the limit value in Ampere “LVA”. Set I^Δ (overcurrent detection value) to LVA-value or slightly lower.
7. Set the hysteresis (HA) to a value lower then the LVA-value. Around one tenth of the LVA-value.
8. Set the function settings to “Memory “ to “NO”, “undercurrent detection” to “off” and “NC Us=on” according to page 2:25-2:26.
9. Start the granulator. >Page 5:1.
10. Check that the current relay’s setting is satisfying, see page 2:25 and 2:26. Adjust as necessary.



Example: Detection of overcurrent

- T₁ is set to 3 sec.
- Rated current is 15 A.
- The granulator is Y/D-started.
- LVA is calculated to 8.7 A.
 $8.7 \text{ A} = 15 / \sqrt{3}$
- HA is set to one tenth of LVA.
 HA is calculated to 0,87 A:
 $0,87 \text{ A} = 0,1 \cdot 8,7 = 8,7 / 10$
- The function setting is set to “Mem? No”, “Excess current” and “NC Us=on”.

The settings in the example means:

During operation, the relay will trip and stop the feed equipment if the granulator’s current consumption exceeds 8.7 A for over 3 seconds.

The function setting “Mem? No” enables the relay to restart the feed equipment when the granulator’s current consumption has sunk to $8,7 - 0,87 = 7,83 \text{ A}$.

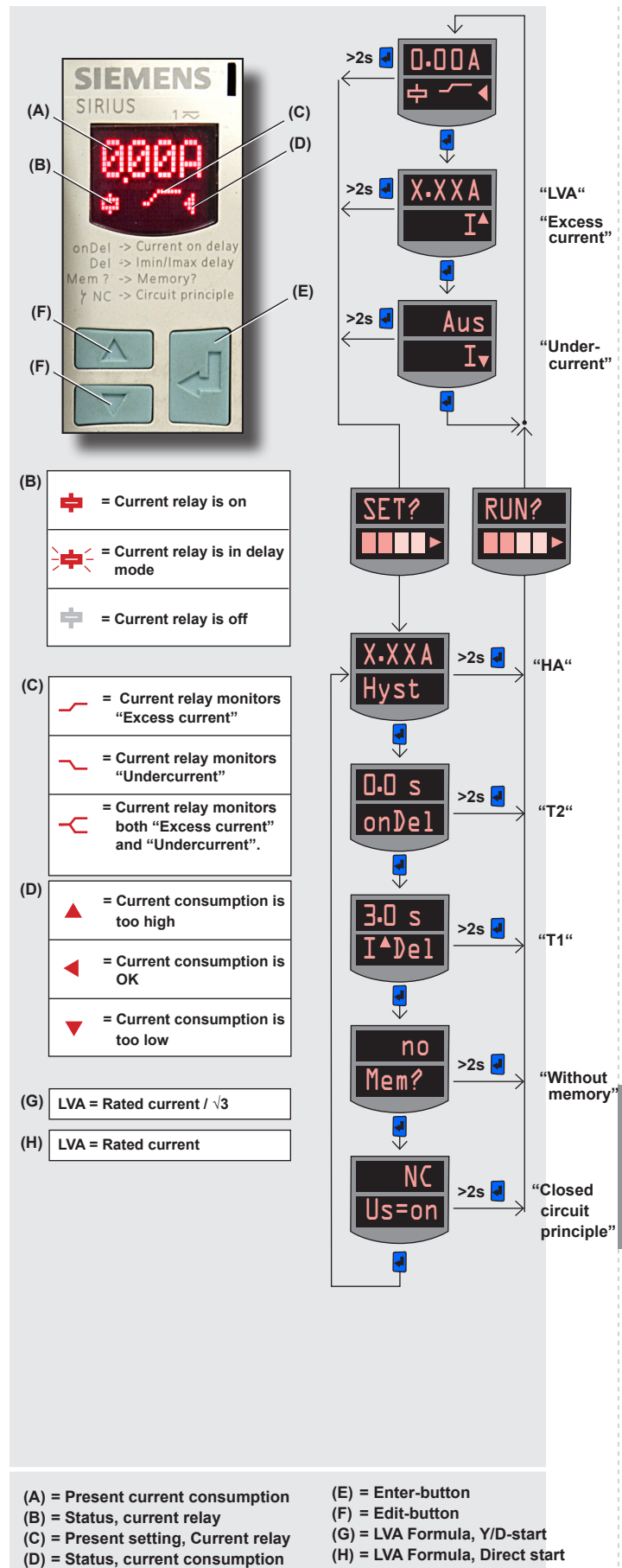

Important tightening torques

Check the tightening torque of important machine parts 30 hours after installation and then regularly every 6 months. Respect specified tightening torques. Use a torque wrench.

1. The rotating knives' tightening screws.
280 Nm.
2. The fixed knives' tightening screws.
300 Nm
3. Screws holding hopper in place.
Max 100 Nm
4. Screws holding screen box in place.
Max 100 Nm

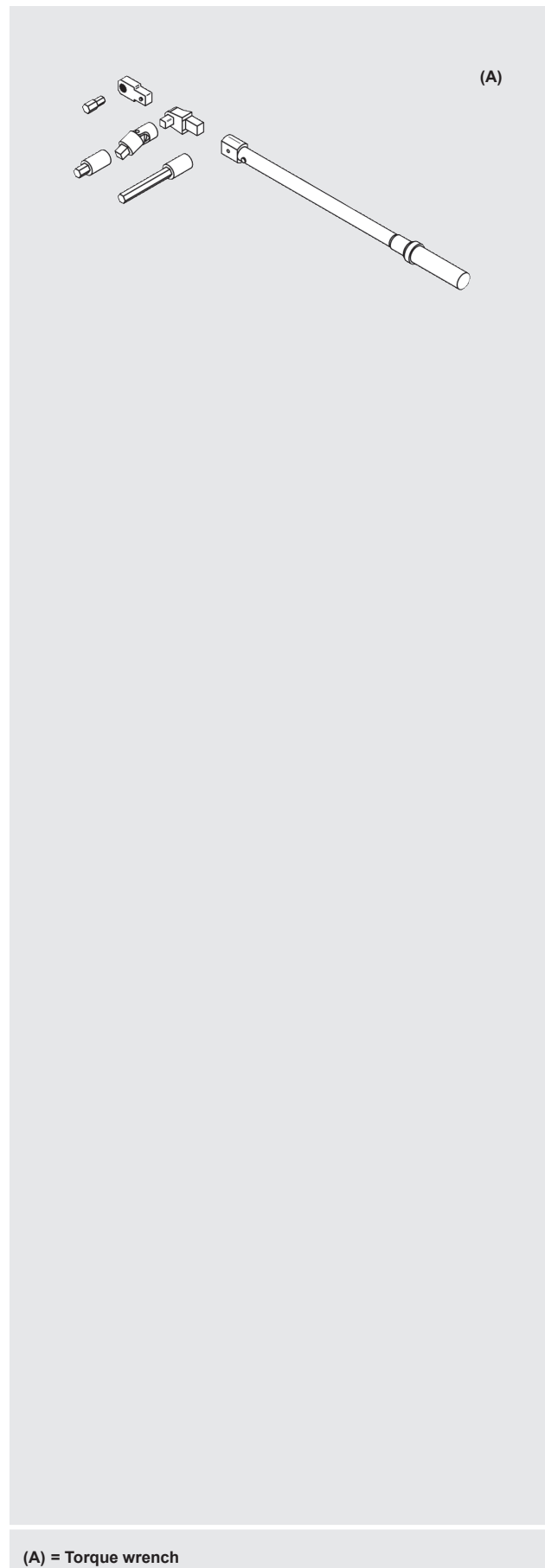

Cleaning

1. Read page 7:1 “General rules, Service”.
2. When granulating material that generates dust:
 - Clean the granulator’s parts once every day or at least once every week.

In normal operation:

- Clean the granulator parts at colour change or at least once every 300 hours.

3. Open the granulator. >Page 6:1.
4. Clean the granulator parts. Use a vacuum cleaner. Clean following parts inside and outside: Inlet, cutter housing, screen, screen box, granule bin and enclosure (option), roller feeder (option).

Important! Do not use compressed air and a blow gun, since granulate and plastic residue could be blown into safety switches. Granulate and plastic residue can make the floor slippery.

5. Additional suffix -U (Blower). Clean the blower, outlet pipe and granule bin very carefully. Use a vacuum cleaner.

Important! When starting, remaining material in the blower, outlet pipe or granule bin can cause serious or irreparable damage to the blower.

6. Close the granulator. >Page 6:4.

Important! If the rotor is stuck, rotate the rotor in the reverse direction, if necessary tap carefully with a piece of wood. Never use any metal object when trying to release the rotor.

Important! If the inlet, cutter housing, screen box and/or granule bin are filled with compact, melt plastic residue – Conair’s distributor or Conair’s head office must be contacted for service.

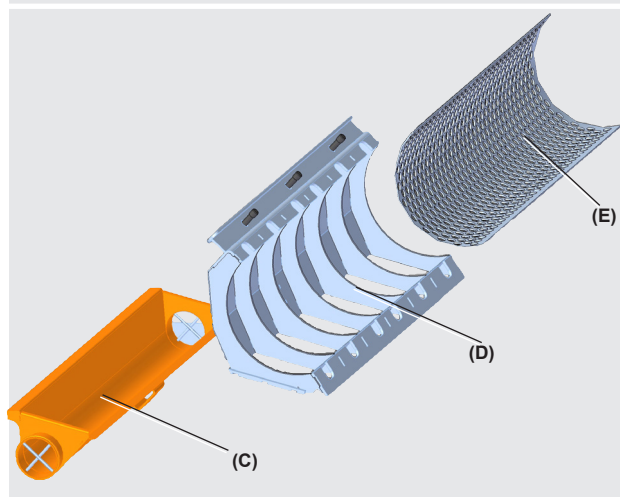
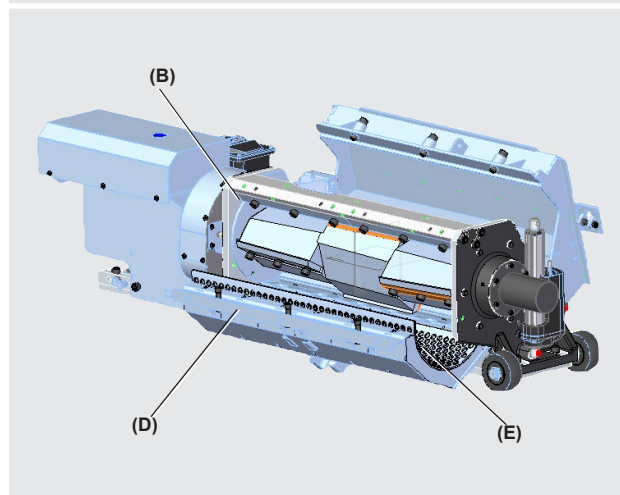
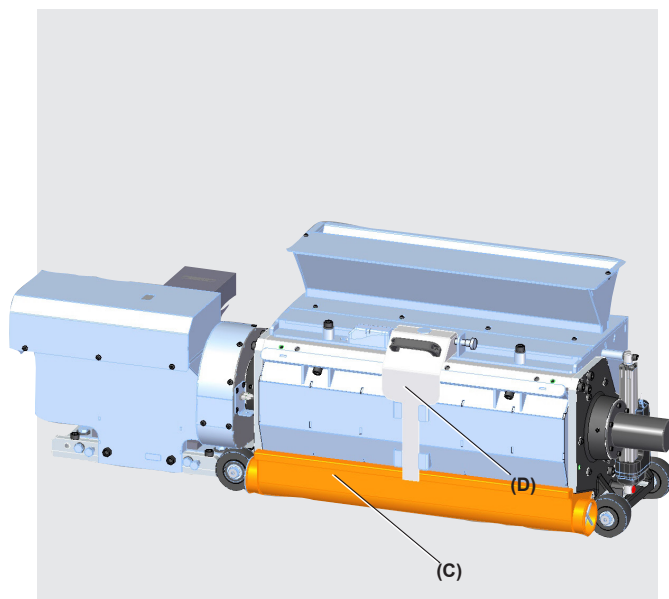

(A) = Roller feeder
 (B) = Cutter housing
 (C) = Granule bin
 (D) = Screen box
 (E) = Screen

Knives

General rules, Knives



1. Read page 7:1 “General rules, Service”.
2. Read page 2:15 “Rotor” and “Rotating knives”.
3. Read page 2:16 “Cutter housing” and “Fixed knives”
4. Read page 2:17 “Grinding fixture”, “Knife clearance” and “Presetting fixture”.
5. All screws and nuts that are sealed with red paint, are permanently set and glued. These screws and nuts must under no circumstances be unscrewed, tightened or changed.
6. Knife sharpness and knife clearance must be checked regularly. The granulator must never be used with blunt knives. Blunt knives cause abnormal wear and damages the granulator. The rotating knives must be replaced or grinded as necessary. The fixed knives must be replaced, grinded or reversed as necessary
7. Every second time tightening screws are unscrewed they must be replaced with new ones.
8. When replacing knives, washers, support rules and tightening screws only use original spare parts supplied by Conair.
9. The rotor can rotate by itself. Always lock the rotor with a piece of wood to prevent the rotor from self-rotating. Risk of cutting or pinch injuries!
10. Respect specified tightening torques. Use a torque wrench.
11. Respect specified measures.

If any of the above listed rules are left unattended, Conair’s responsibility under the Machinery Directive ceases to apply.

Note! When the machine is opened the knives are accessible. The knives are sharp, and they may cause personal injuries even when they are not rotating.

Knives

Remove the rotating knives

1. Read page 7:7 “General rules, Knives”.
2. Open the Screen box. >Page 6:2.
3. Open the Hopper. >Page 6:3.
4. Remove the knives on one knife row at the time.
5. Release the rotor. Rotate the rotor to an appropriate position. Lock the rotor’s position with a piece of wood.
6. Unscrew the rotating knife’s tightening screws.
7. Remove the rotating knife’s supportin rulers.
8. Remove the rotating knife.
9. Repeat point 5–8 until all rotating knives have been removed.

Remove the fixed knives

1. Remove the rotating knives.
 2. Remove one fixed knife at the time. Unscrew the fixed knife’s tightening screws and the fixed knife’s counter thightening screw. Refer to Page 7:12 for images.
- Note!** Do not tighten / unscrew any screws sealed with red paint. These screws are permanently set and glued!
4. Remove the fixed knife and the support rule. (Fixed knife 1st also has washers that must be removed).
 5. Repeat point 2–3 until all fixed knives have been removed.

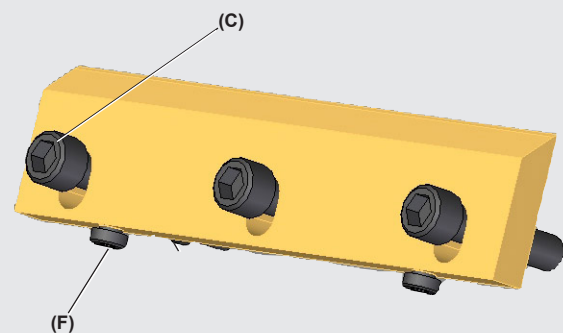
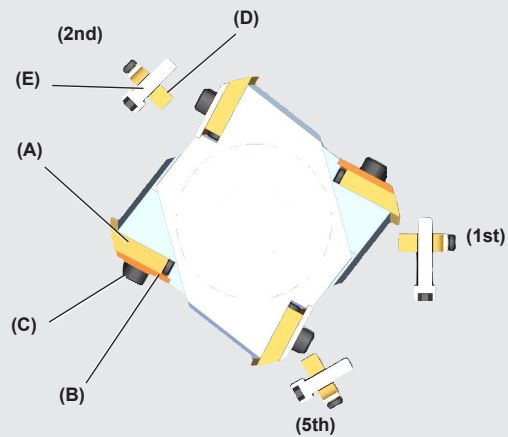
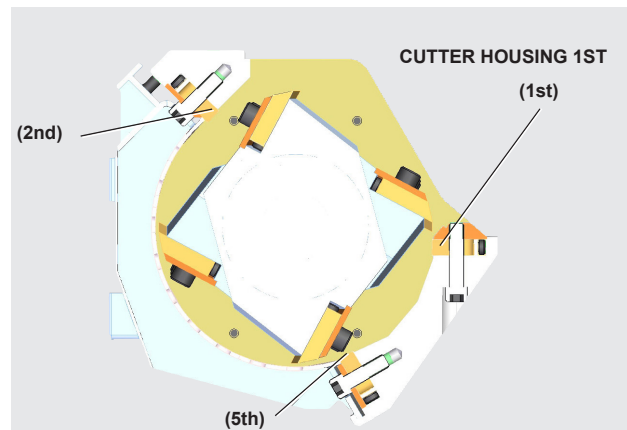

Mark the knife with a marker pen.

- = Tightening screws are correctly torqued.
- = The knife clearance is correct.
- = Knife clearance has been re-checked and is correct.

- (A) = Rotating knife
- (B) = Support ruler, Rotating knife
- (C) = Tightening screw, Rotating knife
- (D) = Fixed knife
- (E) = Tightening screw, Fixed knife
- (F) = Adjusting screw, Rotating knife

Knives

General rules, Grind the knives

1. Read page 7:7 “General rules, Knives”.
2. Always begin grinding the worst and most blunt knife.
3. Grind the knives with accurate precision. It is very important that the relief angle and the cutting angle becomes correct. Respect specified measures.
4. Always cool the knives during grinding. Grind slowly. Make sure that no heat is developed. Knives that are overheated when grinded, loose their hardness, strength and durability. Knives that have been burned or quenched blue, are irreparable and must be discarded.
5. A surface grinder with magnetic table and a grinding fixture ensures that the cutting angles and the relief angles becomes correct.

Grind the fixed knives

1. Read page 7:9 “General rules, Grind the knives”.
 2. Install the fixed knife in the grinding fixture. Refer to the upper figure on the right. Tighten the knife with the grinding fixture’s tightening screws.
 3. Grind the fixed knife’s cutting edge. Use a surface grinder. A correct cutting angle on the fixed knife is 90°. Grind until all irregularities have disappeared.
 4. Remove the knife but keep the settings on the surface grinder.
 5. Measure the knife’s length after grinding.
-  Note! If the fixed knife’s length is less than 40 mm, the old fixed knife must be discarded and replaced by a new fixed knife.
6. Repeat point 2–5 until all fixed knives have been grinded.

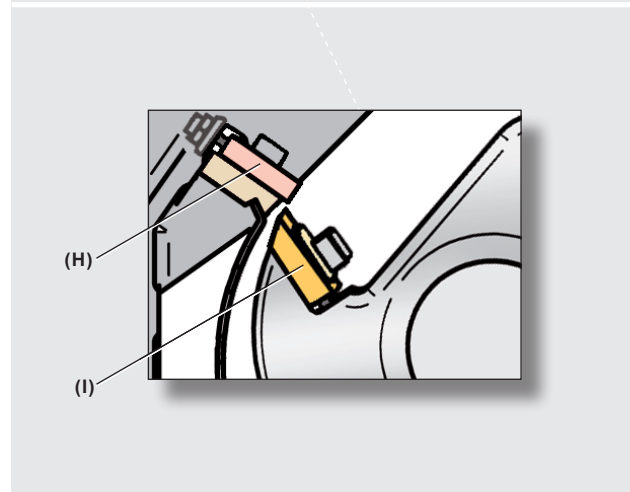
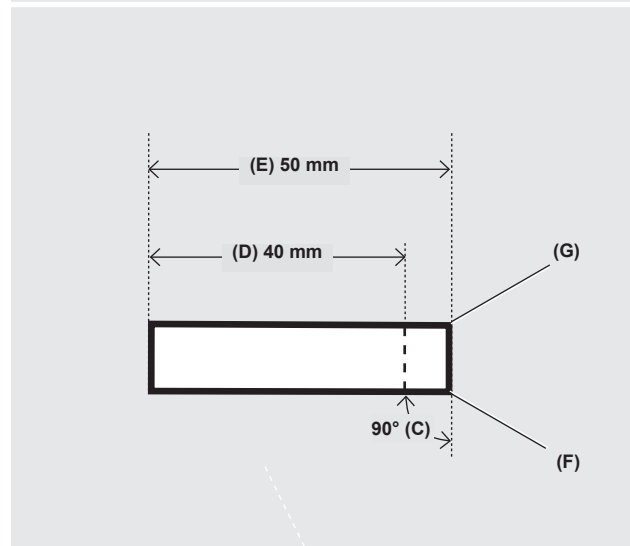
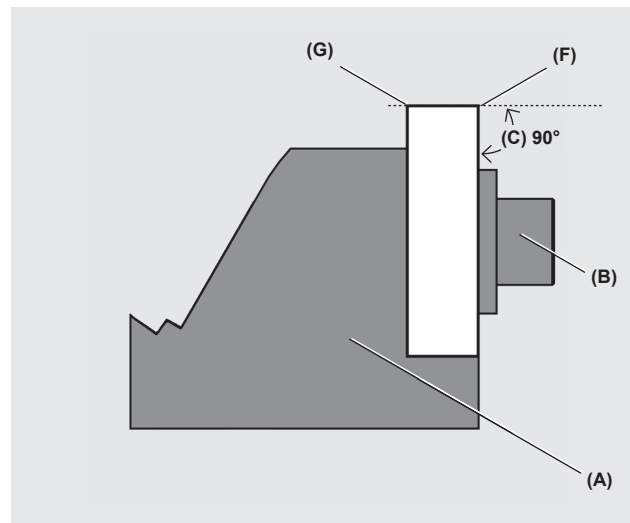

- (A) = Grinding fixture
 (B) = Tightening screw, Grinding fixture
 (C) = Cutting angle, Fixed knife
 (D) = Minimum length, Grinded fixed knife
 (E) = Length, New fixed knife
 (F) = Cutting edge No1, Reversible fixed knife
 (G) = Cutting edge No2, Reversible fixed knife
 (H) = Fixed knife
 (I) = Rotating knife

Knives

Grind the rotating knives

1. Read page 7:9 "General rules, Grind the knives".
2. Install the rotating knife in the grinding fixture. Refer to the upper figure on the right. Install the grinding fixture's washers. Tighten the knife with the grinding fixture's tightening screws.
3. Grind the rotating knife's second relief angle. Use a surface grinder. A correct second relief angle on the rotating knife is 50°. Grind until all irregularities have disappeared.
4. Remove the knife but keep the settings on the surface grinder.



Note! All rotating knives must be grinded equally to maintain the rotor balance. All rotating knives must have the same measure and weight (within a gramme).

5. Repeat point 2–4 until all rotating knives' second relief angles have been grinded.
6. Install the rotating knife in the grinding fixture. Refer to the middle figure on the right. Install the grinding fixture's washers. Tighten the knife with the grinding fixture's tightening screws.
7. Grind the rotating knife's cutting edge and first relief angle. Use a surface grinder. A correct first relief angle on the rotating knife is 55°. Grind until the first relief surface becomes 3 mm.
8. Remove the knife but keep the settings on the surface grinder.
9. Measure the knife's length after grinding.



Note! If the rotating knife's length is less than 60 mm, the old rotating knife must be discarded and replaced by a new rotating knife.

10. Repeat point 6–9 until all rotating knives' cutting edges have been grinded.

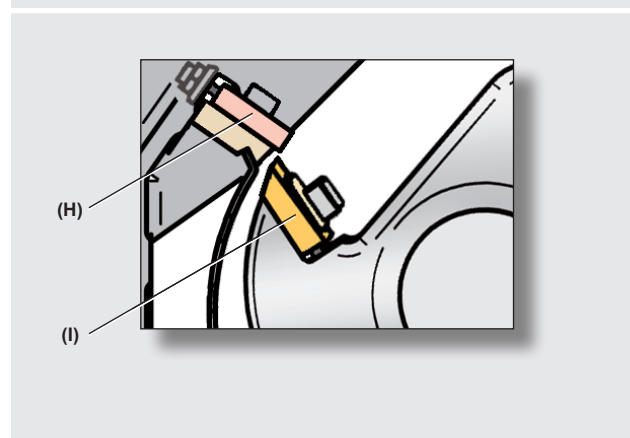
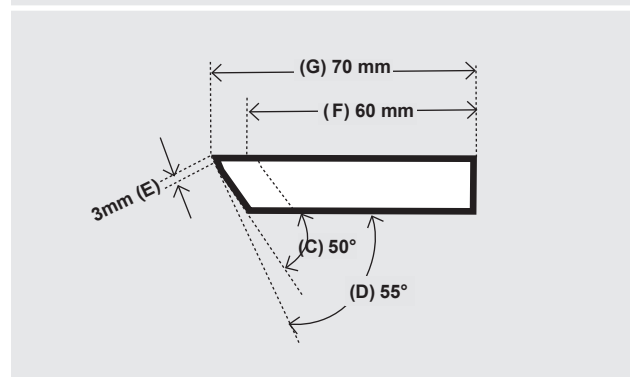
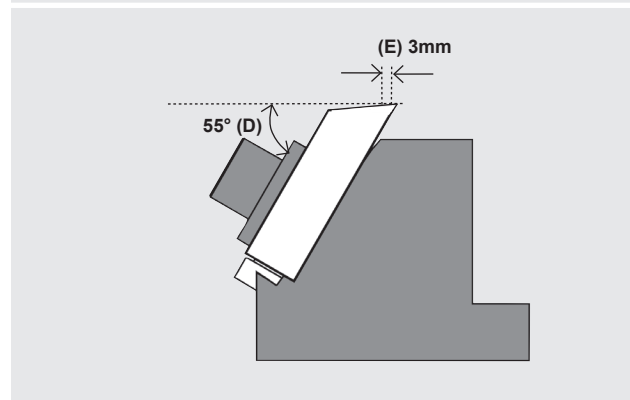
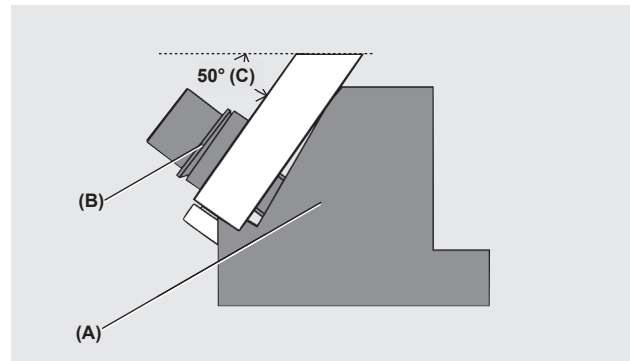

- (A) = Grinding fixture
- (B) = Tightening screws, Grinding fixture
- (C) = Second relief angle, Rotating knife
- (D) = First relief angle, Rotating knife
- (E) = First relief surface, Rotating knife
- (F) = Minimum length, Grinded rotating knife
- (G) = Length, New rotating knife
- (H) = Fixed knife
- (I) = Rotating knife

Knives

General rules, Preset the knives

1. Read page 7:7 “General rules, Knives”.
2. Only preset new or newly grinded knives.

Preset the rotating knives

1. Read page 7:11 “General rules, Preset the knives”.
2. Tighten the knife’s adjusting screws.
3. Install the rotating knife in the presetting fixture. Refer to the upper figure on the right.
4. Install a feeler gauge between the presetting fixture and the knife’s edge.
5. Adjust the knife’s adjusting screws. Use an Allen key. Tighten / unscrew until the feeler gauge begins to bind.
6. Gently remove the feeler gauge and the knife.
7. Repeat point 2–7 until all rotating knives are preset.

Preset the fixed knives

1. Read page 7:11 “General rules, Preset the knives”.
2. Tighten the knife’s adjusting screws.
3. Install the fixed knife in the presetting fixture. Refer to the lower figure on the right.
4. Install the enclosed distance in front of the knife’s edge.
5. Install a feeler gauge between the presetting fixture’s distance and the knife’s edge.
6. Adjust the knife’s adjusting screws. Use an Allen key. Tighten / unscrew until the feeler gauge begins to bind.
7. Gently remove the feeler gauge and the knife.
8. Repeat point 2–8 until all fixed knives are preset.

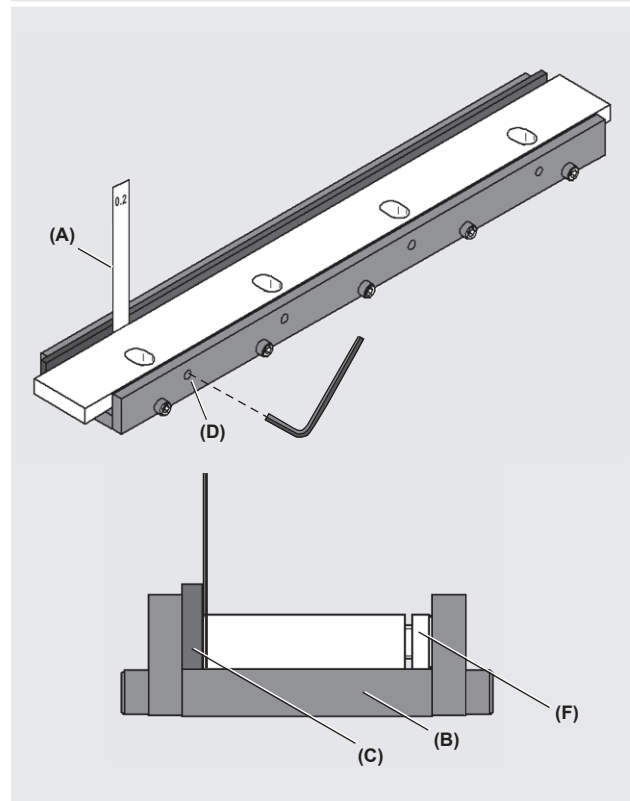
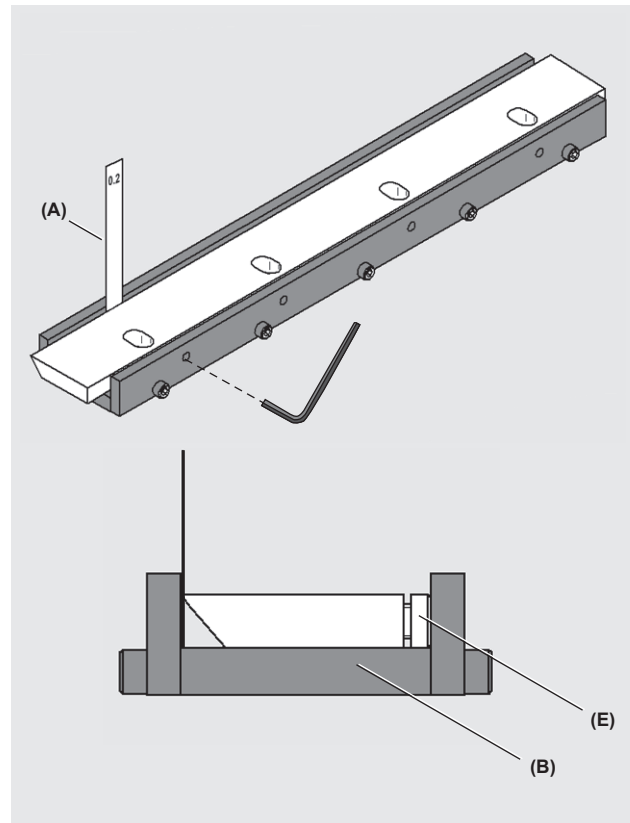

- (A) = Feeler gauge
 (B) = Presetting fixture
 (C) = Distance, Presetting fixture
 (D) = Hole, Presetting fixture
 (E) = Adjusting screws, Rotating knife
 (F) = Adjusting screws, Fixed knife

Knives

Install the fixed knives

1. Read page 7:7 “General rules, Knives”.
2. Preset the fixed knives. >Page 7:11.
3. Open the screen box and the hopper.
>Page 6:2–6:3.
4. Release the rotor. Rotate the rotor to an appropriate position. Lock the rotor’s position with a piece of wood.
5. Check that the knife seat is clean.
6. Install the fixed knife and the support ruler with the counter tightening screws. Tighten the counter tightening screw gently until the tightening screws can be threaded through the cutter house, the fixed knife and the support ruler. Install the tightening screw.
7. Tighten the tightening screw by hand
Tighten the counter tightening screw
Tighten the knife’s tightening screws properly
Tightening torque 300 Nm.



Information! The tightening screws to fixed knife 1st are tightened from the back side of the granulator.



Note! Do not tighten / unscrew any screws sealed with red paint. These screws are permanently set and glued!

8. Mark the knife with a marker pen. Draw a circle: ○
The instruction continues on next page.

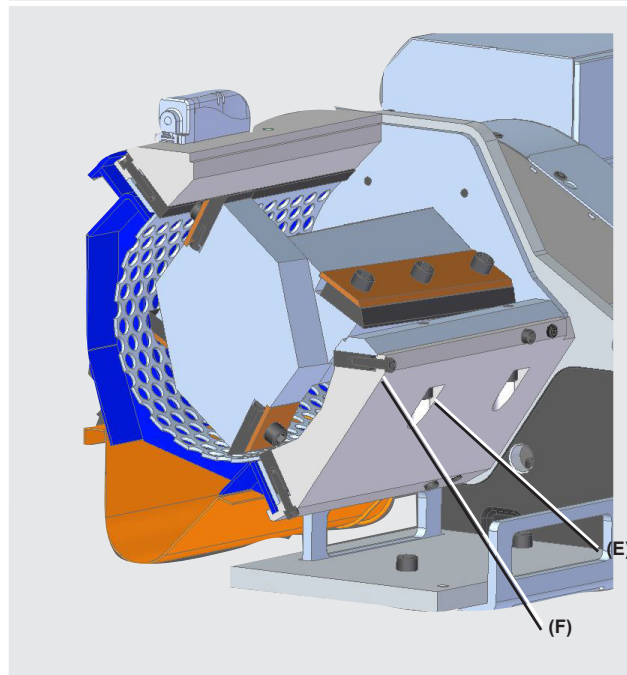
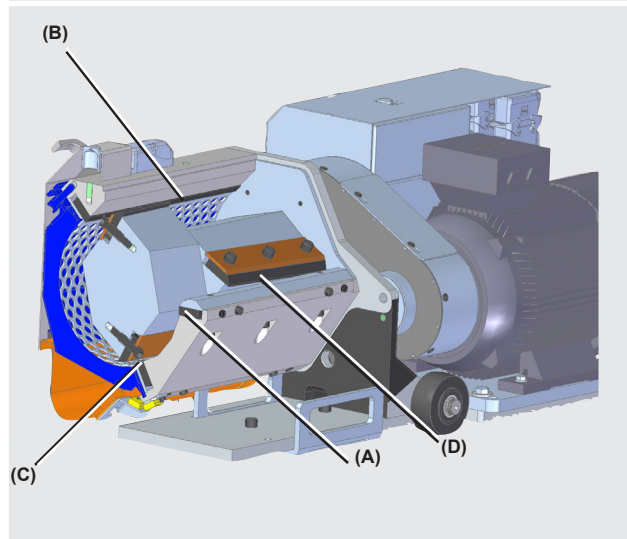
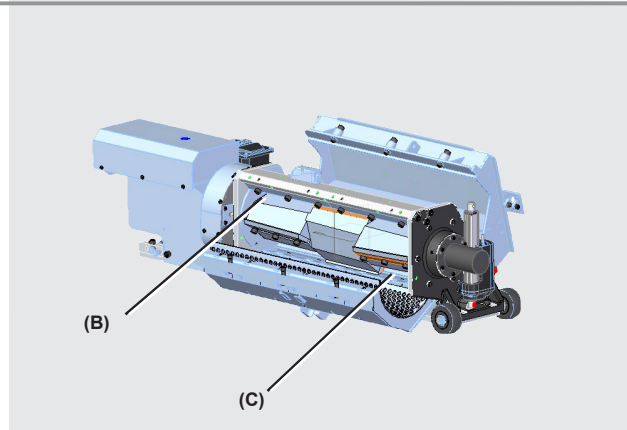

- (A) = 1st knife
- (B) = 2nd knife
- (C) = 5th knife
- (D) = Rotating knife
- (E) = Tightening screw
- (F) = Counter tightening screw

Knives

Install the fixed knives

10. Check the knife clearance. Release the rotor. Rotate the rotor to an appropriate position.



Put a feeler gauge between the fixed knife and the rotating knife. Put the feeler gauge alternately to the right, to the left and in the middle. Correct knife clearance is 0.10 - 0.40 mm. Knife clearance could vary after application.

Mark the knife with a marker pen. Draw a circle and a line that goes through the circle: .

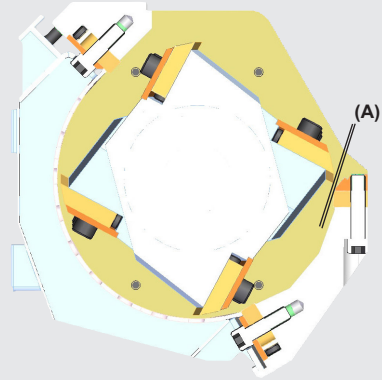
11. Repeat point 5–10 until all fixed knives are installed.
12. Re-check the knife clearance at all knife positions.
>Page 7:13 point 10. Mark all re-checked knives with a marker pen. Draw one more line through the circle: .



Mark the knife with a marker pen.

-  = Tightening screws are correctly torqued.
-  = The knife clearance is correct.
-  = Knife clearance has been re-checked and is correct.

(A) = Knife clearance

Knives

Install the rotating knives

1. Read page 7:7 “General rules, Knives”.
2. Install the fixed knives.
3. Preset the rotating knives. >Page 7:11.
4. Release the rotor. Rotate the rotor to an appropriate position. Lock the rotor’s position with a piece of wood.
5. Check that the knife seat is clean.
6. Install the rotating knife, the ruler and the tightening screws.
7. Press the knife firmly to the bottom of the knife seat. Tighten the knife’s tightening screws. Tightening torque 280 Nm.



Note! Use a rubber head mallet and give the knife a firm punch every now and then meanwhile the tightening torque gradually is increased. This is to ensure that the knife is installed in the very bottom of the knife seat.

8. Mark the knife with a marker pen.
Draw a circle: ○
9. Repeat point 3–7 until all rotating knives have been installed.

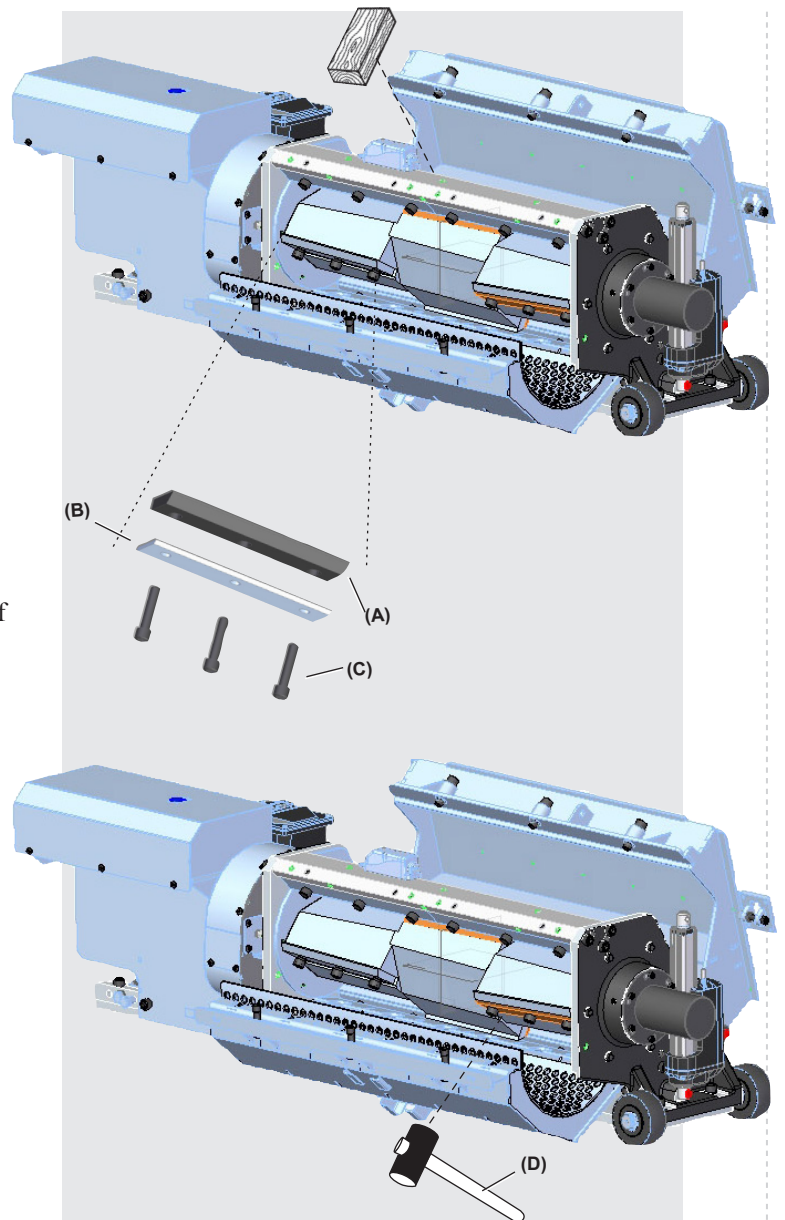

Mark the knife with a marker pen.

- = Tightening screws are correctly torqued.
- = The knife clearance is correct.
- = Knife clearance has been re-checked and is correct.

- (A) = Rotating knife
- (B) = Support ruler
- (C) = Tightening screw, Rotating knife
- (D) = Rubber head mallet

Drive belt

General rules, Drive belt

1. Read page 7:1 “General rules, Service”.
2. Read page 2:18 “Transmission”.
3. First check of belt tension after 0.5–4 hours of operation. Thereafter every 6–12 month.

Check the drive belt

1. Read page 7:15 “General rules, Drive belt”.
2. Open the transmission inspection hatch. >Page 6:1.
3. Check the condition of the drive belt. Check that the drive belt is intact and does not have any cracks.
4. Check the belt tension with a suitable instrument. Correct tension in Page 7:16.
5. Adjust the belt tension as necessary. > Page 7:15
6. Close the transmission inspection hatch. >Page 6:4.

Adjust the belt tension

1. Open the transmission inspection hatch. >Page 6:1.
2. Check the drive belt. >Page 7:15.
3. The belt tension is adjusted by a horizontal adjustment of the motor mounting bracket.
 - Loosen the motor mounting bracket attachment screws (C)
 - Tighten the belt by tightening the tightening screws (D)
 - Loosen the belt tension by loosening the tightening screws
4. Check that the rotor pulley and the motor pulley are in line (tolerance 0.5 mm). Check that the motor and the rotor are parallel. Pull with the adjustment screws to adjust the alignment until the rotor pulley and the motor pulley are in line and the motor and the rotor are parallel.
5. Check the belt tension. >Page 7:15 “Check the drive belt” point 4.
6. Retighten the tightening screws
7. Retighten the motor mounting bracket attachment screws



Note! When drive belts have been adjusted they must be re-checked after 20 hours of operation.

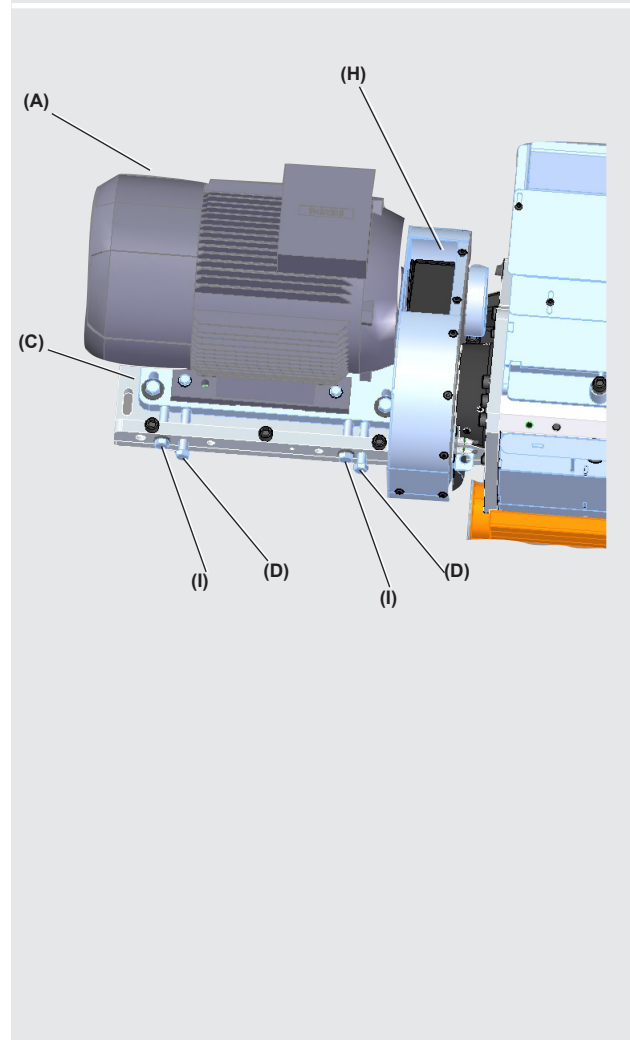
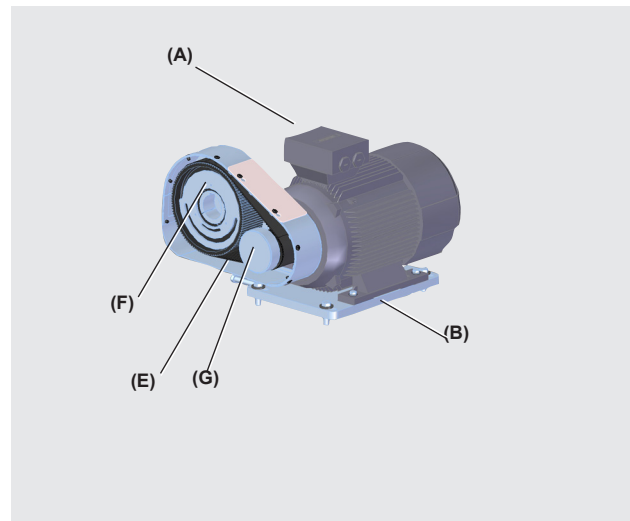

- (A) = Motor
- (B) = Motor mounting bracket
- (C) = Motor mounting bracket attachment screws
- (D) = Tightening screws (pushes the motor mounting bracket)
- (E) = Drive belt(s)
- (F) = Rotor pulley
- (G) = Motor mounting bracket screw
- (H) = Transmission

Belt tension table

Deflection force	11 kW		15 kW	
	Old drive belt	New drive belt	Old drive belt	New drive belt
50 Hz				
Frequency (1/s)				
60 HZ				
Frequency (1/s)				

Deflection force	18.5 kW		22 kW	
	Old drive belt	New drive belt	Old drive belt	New drive belt
50 Hz				
Frequency (1/s)				
60 HZ				
Frequency (1/s)				

Deflection force 174 N	30 kW		kW	
	Old drive belt	New drive belt	Old drive belt	New drive belt
50 Hz				
Frequency (1/s)				
60 HZ				
Frequency (1/s)				

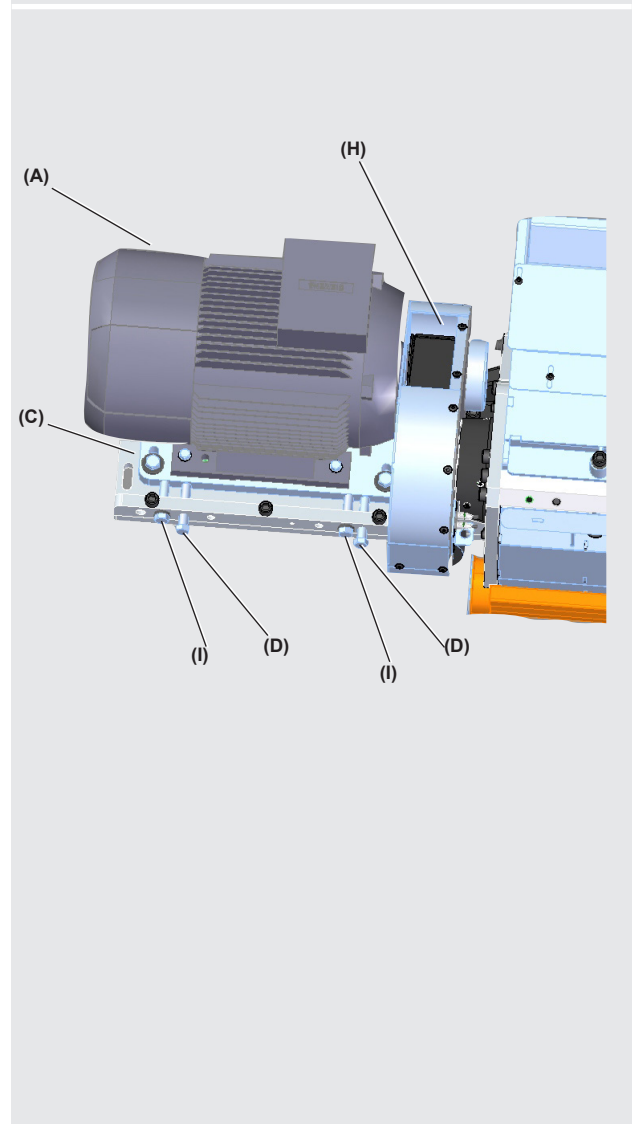
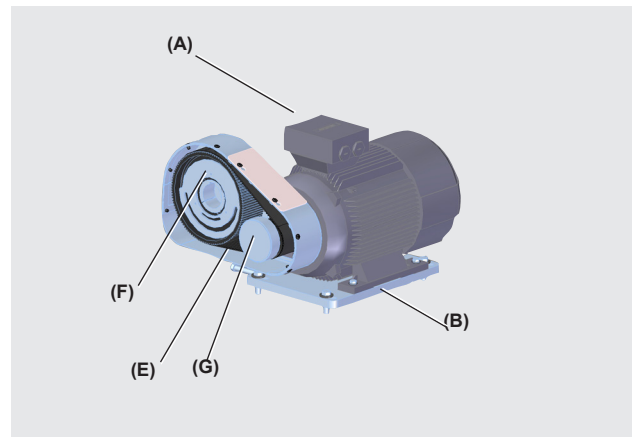

- (A) = Motor
- (B) = Motor mounting bracket
- (C) = Motor mounting bracket attachment screws
- (D) = Tightening screws (pushes the motor mounting bracket)
- (E) = Drive belt(s)
- (F) = Rotor pulley
- (G) = Motor mounting bracket screw
- (H) = Transmission

Fault tracing

Fault	Probable cause	Actions taken
The granulator or any optional equipment do not start or stops unexpectedly.	The emergency stop is activated	1. Reset the emergency stop(s). >Page 5:1.
	The granulator / the optional equipment is not connected to the mains.	1. Connect the granulator to the mains. >Page 4:2. 2. Connect the mains plug on the band conveyor. (Band conveyor = optional).
	The main switch is in position "0".	1. Put the main switch in position "1". >Page 5:1.
	The button "Reset safety relay" has not been pressed.	1. Press the button "Reset safety relay". >Page 5:1 "Start the granulator"
	Screen, screen box, granule bin, inlet, enclosure and/or optional equipment are not properly closed, or their safety switch(es) is/are open.	1. Close the granulator. >Page 6:4. 2. Check that all safety switches are properly installed. >Page 2:22 "Safety switch".
	The granulator's overload protection has tripped since the granulator has been overloaded. or Blower (optional): The blower's overload protection has tripped since the blower has been overloaded.	1. Reset the overload protection. >Page 2:23 "Overload protection". Before restart: 2. Clean the granulator. >Page 7:6. 3. Check the drive belt(s). Adjust the belt tension / replace drive belt(s) as necessary. >Page 7:15. 4. Check knife sharpness and knife clearance. >Page 7:13 point 10.
	The level switch (optional) has stopped the granulator / the optional equipment. or The level switch's mains plug is disconnected.	1. Check the level switch. >Page 7:3. 2. Connect the mains plug on the level switch.
The current relay has stopped the granulator / the optional equipment.	1. If the current relay can be suspected to cause stops, contact electrician.	
The rotor still rotates even if the hopper is opened.	The drive belt(s) is(are) worn or the belt tension is wrong. or The safety equipment is not functioning.	1. Check the drive belt(s). Adjust the belt tension / replace drive belt(s) as necessary. >Page 7:15. 2. Check the safety equipment. >Page 7:2.
		1. Lock the main switch in position "0". 2. Press the emergency stop(s). 3. Contact the personnel responsible for the machine's service and safety. 4. In event of any questions, please contact Conair's local distributor or Conair's head office.
The granulator or any optional equipment do not start after normal fault tracing.		1. Lock the main switch in position "0". 2. Press the emergency stop(s). 3. Contact the personnel responsible for the machine's service and safety. 4. In event of any questions, please contact Conair's local distributor or Conair's head office.



Service actions, Once every month

Month 20 Sign:.....

Rotating knife: Existing knives, Approved. Knives and screws, Replaced. Support rules, Replaced.

Fixed knife: Existing knives, Approved. Knives and screws, Replaced. Support rules, Replaced.

Screen: Existing Screen, Approved. Screen, Replaced. **Other remarks:**.....

Month 20 Sign:.....

Rotating knife: Existing knives, Approved. Knives and screws, Replaced. Support rules, Replaced.

Fixed knife: Existing knives, Approved. Knives and screws, Replaced. Support rules, Replaced.

Screen: Existing Screen, Approved. Screen, Replaced. **Other remarks:**.....

Month 20 Sign:.....

Rotating knife: Existing knives, Approved. Knives and screws, Replaced. Support rules, Replaced.

Fixed knife: Existing knives, Approved. Knives and screws, Replaced. Support rules, Replaced.

Screen: Existing Screen, Approved. Screen, Replaced. **Other remarks:**.....

Month 20 Sign:.....

Rotating knife: Existing knives, Approved. Knives and screws, Replaced. Support rules, Replaced.

Fixed knife: Existing knives, Approved. Knives and screws, Replaced. Support rules, Replaced.

Screen: Existing Screen, Approved. Screen, Replaced. **Other remarks:**.....

Month 20 Sign:.....

Rotating knife: Existing knives, Approved. Knives and screws, Replaced. Support rules, Replaced.

Fixed knife: Existing knives, Approved. Knives and screws, Replaced. Support rules, Replaced.

Screen: Existing Screen, Approved. Screen, Replaced. **Other remarks:**.....

Month 20 Sign:.....

Rotating knife: Existing knives, Approved. Knives and screws, Replaced. Support rules, Replaced.

Fixed knife: Existing knives, Approved. Knives and screws, Replaced. Support rules, Replaced.

Screen: Existing Screen, Approved. Screen, Replaced. **Other remarks:**.....

Service actions, Once every 6th month

Date / 20 Sign:.....

Drive belt(s): Drive belt(s) / Belt tension, Approved. Belt tension, Adjusted. Drive belt(s), Replaced..



Other remarks

Date / 20 Sign:.....

Other remarks:.....

Date / 20 Sign:.....

Other remarks:.....

Date / 20 Sign:.....

Other remarks:.....

Date / 20 Sign:.....

Other remarks:.....

Date / 20 Sign:.....

Other remarks:.....

Date / 20 Sign:.....

Other remarks:.....

Date / 20 Sign:.....

Other remarks:.....

Date / 20 Sign:.....

Other remarks:.....

Date / 20 Sign:.....

Other remarks:.....

Date / 20 Sign:.....

Other remarks:.....

Date / 20 Sign:.....

Other remarks:.....

Date / 20 Sign:.....

Other remarks:.....

General rules, Spare parts



Note! When replacing machinery parts, only use original spare parts supplied by Conair. Spare parts orders should be sent to Conair’s local distributor. The following must be specified when spare parts are ordered:

- Serial number according to the machine’s type plate.
- Machine type according to the machine’s type plate.
- Manufacturing year.
- GB-detail, Specification, Article No and Q (Quantity) according to this spare part catalogue.

The performance of your supplied machine may vary from the standard machines described in this instruction manual. In event of any questions, please contact Conair’s local distributor or Conair’s head office.

Overview

Feed tray, Funnel.....	9:2
Inlet	9:3
Flap(s)	9:4
Hopper.....	9:5
Hopper device	9:7
Safety, Hopper & Cutter housing.....	9:9
Cutter housing.....	9:11
Rotor	9:13
Knives.....	9:14
Screen box, Screen.....	9:16
Granule bin.....	9:17
Transmission, Motor, Flywheel	9:18
Safety, Transmission	9:20
Safety, Enclosure.....	9:21
Safety, Electrical cabinet.....	9:24
Body.....	9:26
Options.....	9:27
Material transport.....	9:28
Blower.....	9:29

Note! Article numbers in grey colour (MF006...) is only for internal use, i.e. grey article numbers can not not be used as a customer article number.

Designations in the spare part catalogue

P	SE	DE	FR	GB-DETAIL	SPECIFICATION	Art No	Q	M	V
(A)	KUTTER	ROTOR	ROTOR	ROTOR		MF0060102	1	120	3BL
1	SKRUV	SCHRAUBE	VIS	SCREW	SHS MC6S 5X14	838151	5	60	
					SHS MC6S 5X14 HARDENED	832257*	5	60	
					SHS MC6S 6X20	834521	10	90	
					SHS MC6S 6X20 HARDENED	834522*	10	90	
2	MUTTER	MUTTER	ÉCROU	NUT		9-40213	9	XX	-S

P = Position number Art No = Article number Q = Quantity M = Model number V = Variant

If anything has been specified in the M “Model No” column, the item only applies to that model No.

If anything has been specified in the V “Variant” column, the item only applies to that machinery variant.

Feed tray, Funnel

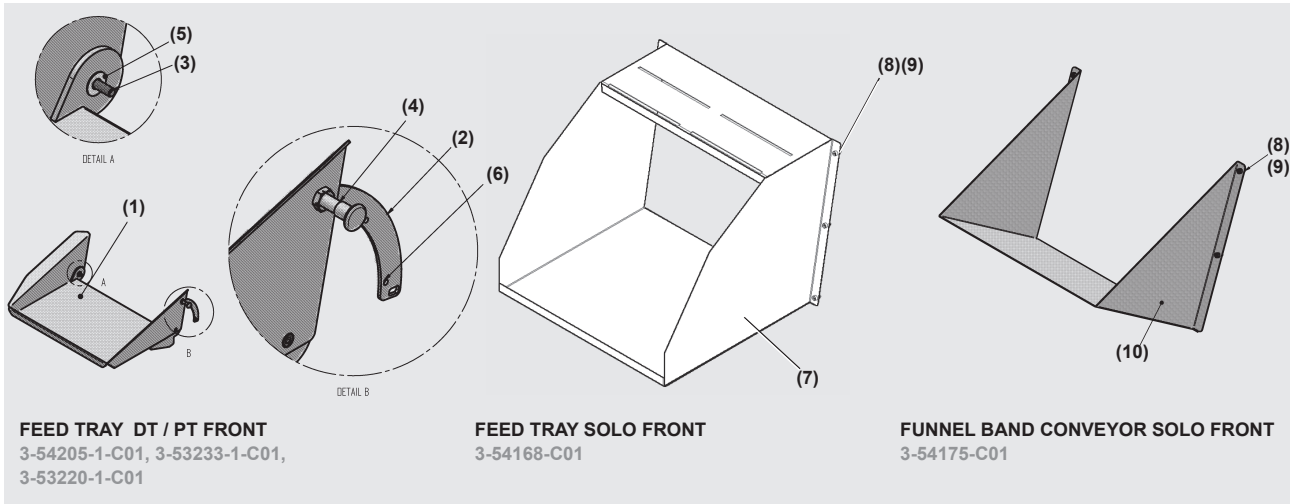

FEED TRAY DT / PT FRONT
3-54205-1-C01, 3-53233-1-C01,
3-53220-1-C01

FEED TRAY SOLO FRONT
3-54168-C01

FUNNEL BAND CONVEYOR SOLO FRONT
3-54175-C01

P	SE	FR	DE	GB - DETAIL	SPECIFICATION	ART NO	Q	M	V	
1	INMATNINGS-BORD	TABLE D'ALIM	AUFGABETIS	FEED TRAY	---	8358697	1	30	DT, PT	
					---	8358172	1	45		
					---	8353992	1	60		
2	HÅLLARE	SUPORTE	HALTER	HOLDER	FEED TRAY	8358546	1	XX	DT, PT	
3	SKRUV	VIS	SCHRAUBE	SCREW	SHS MC6S 8X20	940070	2	XX		
4	POP-NIT	RIVET	NIET	POP-RIVET	STEEL D 4,8X20,0	9-40623	3	XX		
5	FJÄDER	RESSORT	FEDER	DISK SPRING		9-40961	2	XX		
6	INFÄSTNINGS-BULT	BILLE DE POI	KUGELKOPF	POSITIONING BOLT	WN05 30-M8	9-50764	1	XX		
7	INMATNINGS-BORD	TABLE D'ALIM	AUFGABETIS	FEED TRAY	SOLO	8354651	1	45	S	
8	SKRUV	VIS	SCRAUBE	SCREW	SHS MC6S 8X16	9-40032	6	45	S, SB	
9	MUTTER	ÉCROU	MUTTER	NUT	LOC-KING M 8	9-40317	6	45		
10	TRATT	ENTONNOIR	TRICHTERAU	FUNNEL	BAND CONV	8354701	1	45	SB	
(XX = 30, 45, 60)		(DT = DELTA TECH)		(PT = POWER TECH)		(S = SOLO)		(SB = SOLO BAND CONVEYOR)		

Inlet

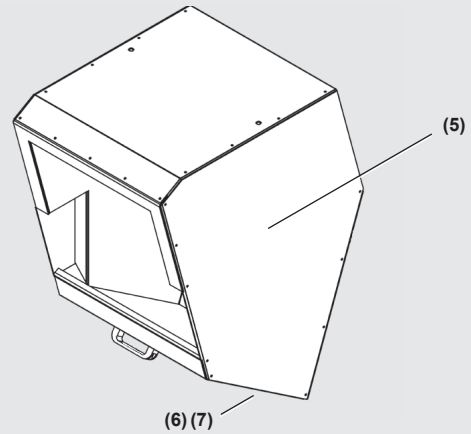
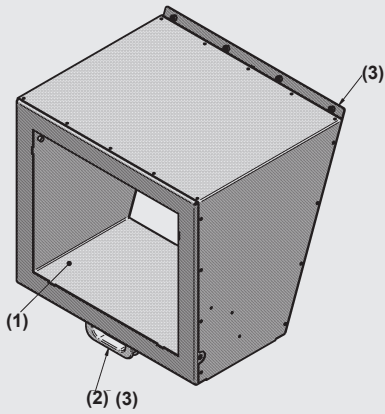

INLET MANUAL FEED DT / PT FRONT (KU INLET)
3-54193-1-C01, 3-54194-1-C01, 3-54195-1-C01

INLET BAND CONVEYOR DT / PT FRONT (KUB INLET)
3-40253-C02, 3-38501-C02, 3-38279-C02

P	SE	FR	DE	GB - DETAIL	SPECIFICATION	ART NO	Q	M	V
1	INLOPP	ENTRÉE	EINLASS	INLET	305X260 ENC	8258673	1	30	MF
					455X260 ENC	8258672	1	45	
					605X260 ENC	8258671	1	60	
2	LIST	BAGUETTE	LEISTE	LIST	7X10 MM	9-70282	1	XX	MF, BC
3	HANDTAG	POIGNÉE	GRIFF	HANDLE	CLAMP VN 130132-M8	9-91984	1	XX	
4	SKRUV	VIS	SCHRAUBE	SCREW	SHS MC6S 8X20	9-40070	5	30	
							5	45	
							6	60	
5	INLOPP	ENTRÉE	EINLASS	INLET	BAND CONV	8240254	1	30	BC
						8238502	1	45	
						8238280	1	60	
6	UNDERPLÅT	PLAQUE INFÉ	UNTERBLECH	BOTTOM PLATE	ENC INLET BAND	8340256	1	30	BC
						8340107	1	45	
						8338290	1	60	
7	SKRUV	VIS	SCHRAUBE	SCREW	MONTAGE DRILWICKPH	9-40750	14	30	
							16	45	
							18	60	

(XX = 30, 45, 60)

(MF = MANUAL FEED)

(BC = BAND CONVEYOR)

Flap(s)

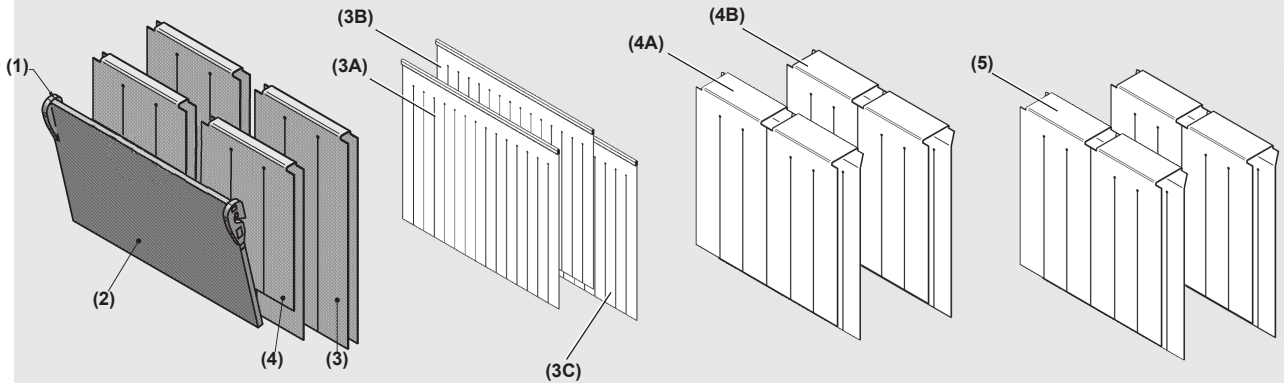

FLAPS MANUAL FEED (KU INLET)
3-54199-C01, 3-54200-1-C01, 3-54201-1-C01

FLAPS BAND CONVEYOR (KUB INLET)
3-40272-C01, 3-40271-C01, 3-40270-C01

FLAPS SOLO
3-54170-C01

FLAPS SOLO WITH BAND CONVEYOR
3-54176-1-C01

P	SE	FR	DE	GB - DETAIL	SPECIFICATION	ART NO	Q	M	V	
1	GÅNGJÄRN	CHARNIÈRE	SCHARNIER	HINGE FLAP		8353923	2	XX	MF	
2	KLAFFPAKET	ENSEMB VOL	KLAPPENPAK	FLAP PARCEL	INLET 305X260	8358695	1	30		
					INLET 455X260	8359694	1	45		
					INLET 605X260	8358693	1	60		
3	KLAFFAR	VOLET	KLAPPEN	FLAPS	318X600	8358692	1	30		
					480X600	8358691	1	45		
					310X500	8385690	2	60		
4	KLAFFAR	VOLET	KLAPPEN	FLAPS	318X300/400	8358689	1	30		
					480X300/400	8358688	1	45		
					310X300/400	8358687	2	60		
3	KLAFFAR	VOLET	KLAPPEN	FLAP	3A) 304X700 PUR STRIPED	8340267	1	30		BC
					3B) 304X900 PUR STRIPED	8340269	1			
					3C) 304X800 PUR STRIPED	8340268	1			
					3A) 454X700 PUR STRIPED	8340265	1	45		
					3B) 454X900 PUR STRIPED	8340266	1			
					3C) MIDDLE 454X740	8320895	1			
					3A) 604X700 PUR STRIPED	8340263	1	60		
					3B) 604X700 PUR STRIPED	8340264	1			
					3C) 604X800 PUR STRIPED	8329254	1			
4	KLAFFAR	VOLET	KLAPPEN	FLAPS	235X400/600	8354650	2	45	S	
					235X500/600	8354649	2			
5	KLAFFAR	VOLET	KLAPPEN	FLAPS	235X500/600	854649	2	45	S-BC	
(XX = 30, 45, 60) (MF = MANUAL FEED) (BC = BAND CONVEYOR) (S = SOLO)										

Hopper

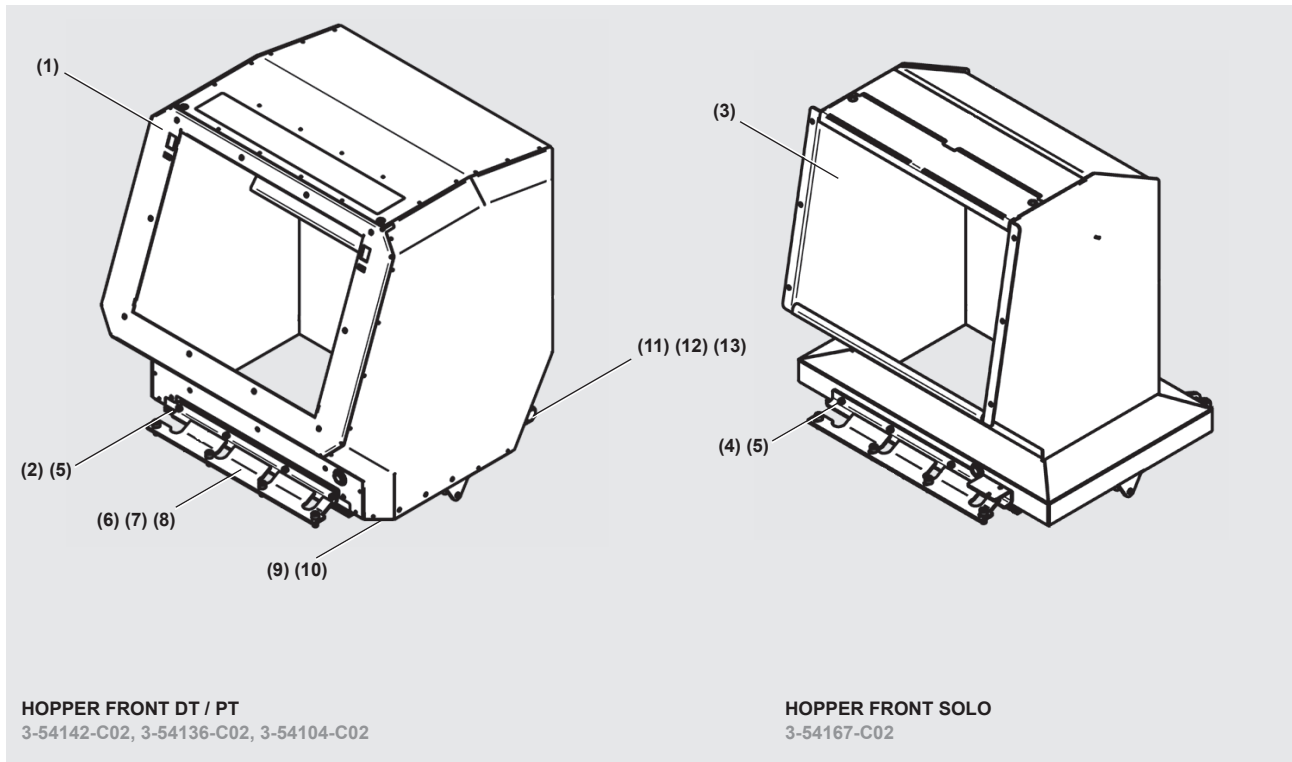

HOPPER FRONT DT / PT
3-54142-C02, 3-54136-C02, 3-54104-C02

HOPPER FRONT SOLO
3-54167-C02

P	SE	FR	DE	GB - DETAIL	SPECIFICATION	ART NO	Q	M	V
1	INMATNING	ALIMENTATIO	TRICHTER	HOPPER	FRONT 300X260	8254592	1	30	F
					FRONT 450X260	8254560	1	45	
					FRONT 600X260	8254622	1	60	
2	LÅSLINJAL	RÈGLE	LINEAL	LOCKING RULER	ROSV	8354603	1	30	F
						8354571	1	45	
						8354633	1	60	
3	INMATNING	ALIMENTATIO	TRICHTER	HOPPER	FRONT 450X260 SOLO	8154654	1	45	S
4	LÅSLINJAL	RÈGLE	LINEAL	LOCKING RULER	SOLO KROSV	8354665	1		
5	SKRUV	VIS	SCHRAUBE	SCREW	SHS MC6S 8X25	9-40097	3	30	F, S
							4	45	
							4	60	
6	LÅSLINJAL	RÈGLE	LINEAL	LOCKING RULER	FRONT BOR. KROSV	8354604	1	30	F, S
						8354572	1	45	
						8354634	1	60	
7	UNDERPLÅT	PLAQUE	BLECH	BOTTOM PLATE	LOCK RULER, KROSV	8354605	1	30	F, S
						8354573	1	45	
						8354635	1	60	
8	SKRUV	VIS	SCHRAUBE	SCREW	SHS MC6S 12X25	9-40051	2	30	F, S
							4	45	
							4	60	
9	TÄTNING	JOINT D'ÉTAN	DICHTUNG	SEALING	FRONT PIECE	8354703	1	30	F, S
						8354704	1	45	
						8354705	1	60	
10	SKRUV	VIS	SCHRAUBE	SCREW	TAPPING TAPTITE 5X12	9-41047	4	XX	
11	CYLINDBULT	BOULON CYL	ZYLINDERBOL	CLEVIS PIN	B20X60X5 ST ISO2341	9-40913	2	XX	
12	SAXPINNE	GOUPILLE F	STIFT	SPLIT PIN	SP 5,0 X 36 FZB	9-41044	2	XX	
13	BRICKA	RONDELLE	SCHEIBE	WASHER	BRB 21,0	9-40313	2	XX	

(XX = 30, 45, 60)

(F = FRONT DELTA TECH / POWER TECH)

(S = HOPPER FRONT SOLO)

Hopper

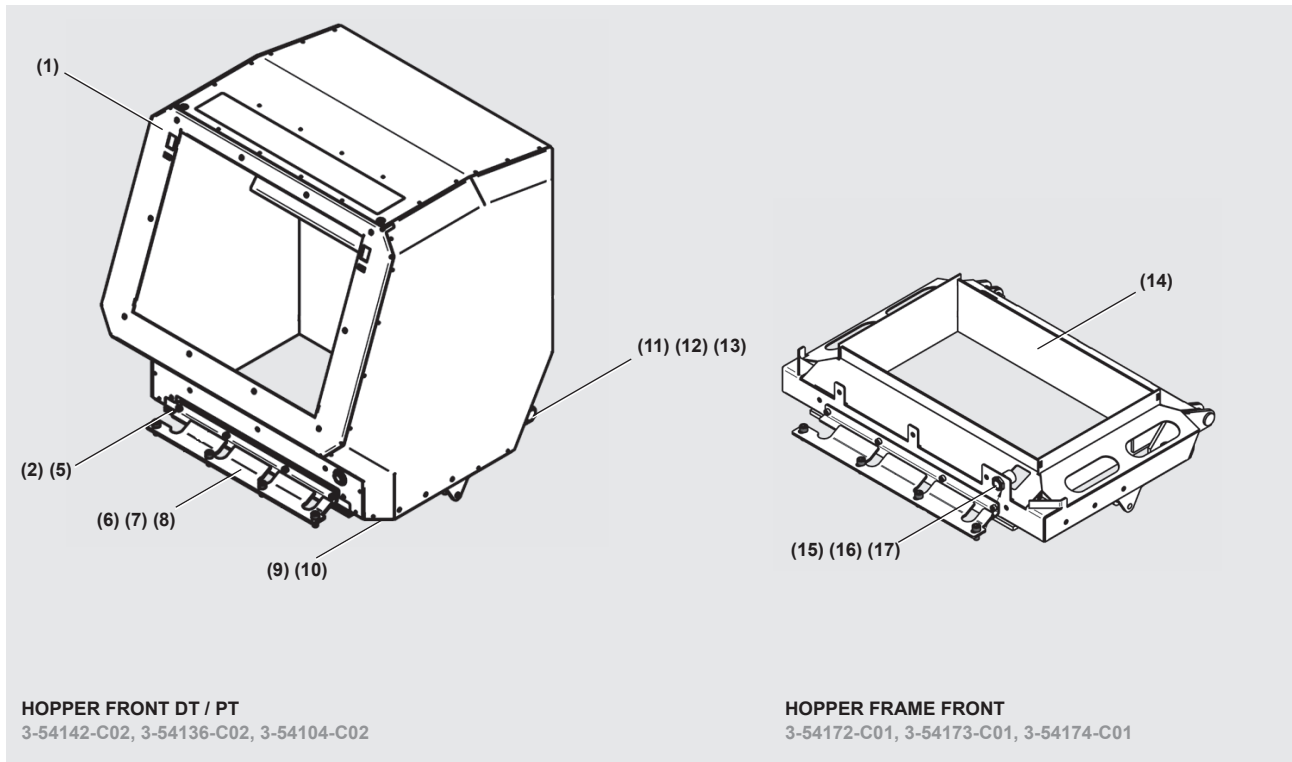

P	SE	FR	DE	GB - DETAIL	SPECIFICATION	ART NO	Q	M	V
14	INMATNRAM	FRAME	FRAM	INNER PART FRONT	(HOPPER FRAME)	8154687	1	30	HF
					450X260 US (HOP FRAME)	8154688	1	45	
					(HOPPER FRAME)	8154689	1	60	
15	SLANG SKYD	PROTECTION	SCHUTZ	HOSE PROTECTION	PAFL 21	9-10864	1	XX	
16	FÖRSKRUVNI	FITTING HOS	FITTING HOSE	FITTING HOSE	AL21 PG16	9-10867	2	XX	
17	MUTTER	ÉCROU	MUTTER	NUT CHEEK	22,5 E1465462 PLAST	9-11303	2	XX	
(XX = 30, 45, 60) (F = <input type="checkbox"/> FRONT DELTA TECH / POWER TECH) (S = HOPPER FRONT SOLO)									

Hopper device

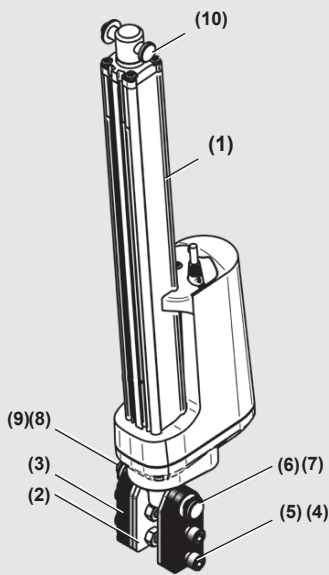

HOPPER DEVICE (JACK)
LINEAR ACTUATOR 6800N CC=530 SL180
 3-54114-C02

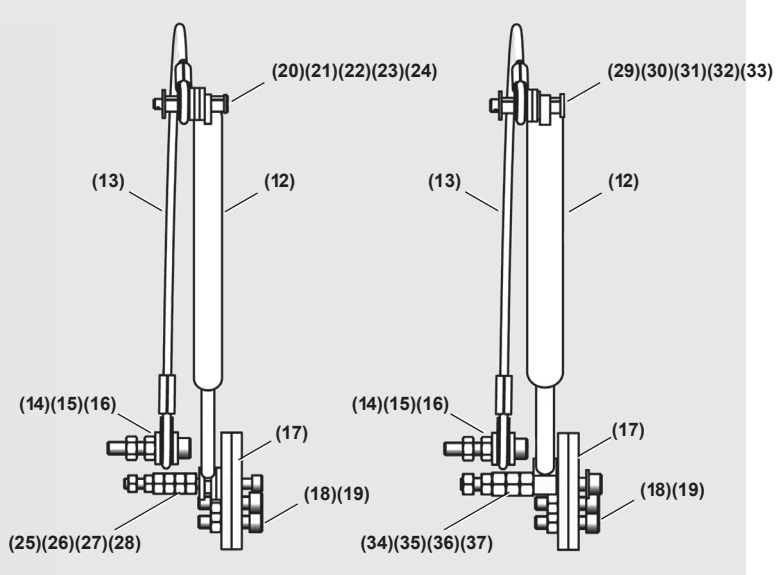

HOPPER DEVICE (GS S)
GAS SPRING 700-1150N
 3-54105-C03

HOPPER DEVICE (GS L)
GAS SPRING 1300-2100N
 3-54105-C03

P	SE	FR	DE	GB - DETAIL	SPECIFICATION	ART NO	Q	M	V
1	STÄLLDON	JACK ELECT	HEBER ELEKT	LINEAR ACTUATOR	LA36 530+140 (6800N)	9-30326	1	XX	JACK
2	FÄSTE	FIXATION	BEFESTIGUN	BRACKET	B=5 LINEAR ACTUATOR	8453427	3	XX	
3	FÄSTE	FIXATION	BEFESTIGUN	BRACKET	B=8 LINEAR ACTUATOR	8453428	4	XX	
4	MUTTER	ÉCROU	MUTTER	NUT	M6M M 10 FZB	9-40030	4	XX	
5	MUTTER	ÉCROU	MUTTER	NUT	BRB 13,0	9-40155	3	XX	
6	SAX PINNE	GOUPILLE F	STIFT	SPLIT PIN	ISO1234 3,2X20ST FZB	9-40946	2	XX	
7	CYLINDBULT	BOULON CYL	ZYLINDERBO	CLEVIS PIN	B12X100X3,2 ISO2341	9-41040	1	XX	
8	BUSSNING	DOUILLE	BÜCHSE	BUSHING	D=25/12-15 RUBBER	8453429	2	XX	
9	SKRUV	VIS	SCHRAUBE	SCREW	SHS MC6S 10X40 DELTA	9-41015	4	XX	
10	CYLINDBULT	BOULON CYL	ZYLINDERBO	CLEVIS PIN	B12X55X3,2 ISO2341	9-41039	1	XX	
11	AUX BLOCK	AUX BLOCK	AUX BLOCK	AUX BLOCK	M22-K01	9-12029	1	XX	ALL GS
12	GASFJÄDER	RESSORTGAZ	GASFEDER	GAS SPRING	REFER TO GAS SPRING TABLE BELOW		1	XX	
13	VAJER	WIRE	WIRE	WIRE	HOPPER STOP WIRE	9-50761	1	XX	
14	SKRUV	VIS	SCHRAUBE	SCREW	SHS MC6S 10X55	9-40293	1	XX	
15	MUTTER	ÉCROU	MUTTER	NUT	M6M M 10 FZB	9-40030	2	XX	
16	BRICKA	RONDELLE	WASHER	WASHER	10.5X25X4 DIN7349 FZB	9-40117	2	XX	
17	FÄSTE	FIXATION	BEFESTIGUNG	BRACKET	B=8 GAS SPRING KROSV	8453635	2	XX	
18	SKRUV	VIS	SCHRAUBE	SCREW	SHS MC6S 10X40 DELTA B	9-41015	2	XX	
19	MUTTER	ÉCROU	MUTTER	NUT	M6M M 10 FZB	9-40030	2	XX	

GAS SPRING, GS S		
011	300 N	9-94299
001	700 N	9-21039
002	800 N	9-21040
003	900 N	9-21041
004	1000 N	9-21042
005	1150 N	9-21043

GAS SPRING, GS L		
006	1300 N	9-21034
007	1500 N	9-21035
008	1700 N	9-21036
009	1900 N	9-21037
010	2100 N	9-21038

MF354102-***

*** = ADD 001, 002, ETC

EXAMPLE:

MF354102-008 = COMPLETE SET GAS SPRING 1700 N

(XX = 30, 45, 60) (JACK = LINEAR ACTUATOR) (GS S = GAS SPRING, SMALL) (GS L = GAS SPRING L) (ALL GS = ALL GAS SPRINGS)

Hopper device

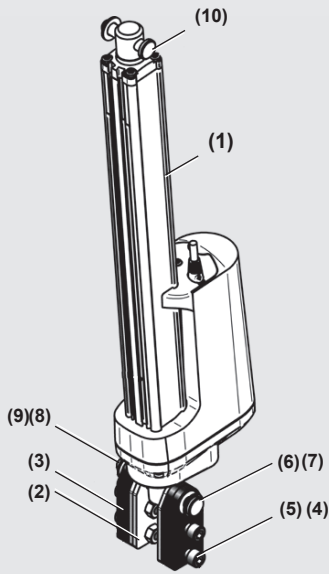

HOPPER DEVICE (JACK)
 LINEAR ACTUATOR 6800N CC=530 SL180
 3-53114-C04

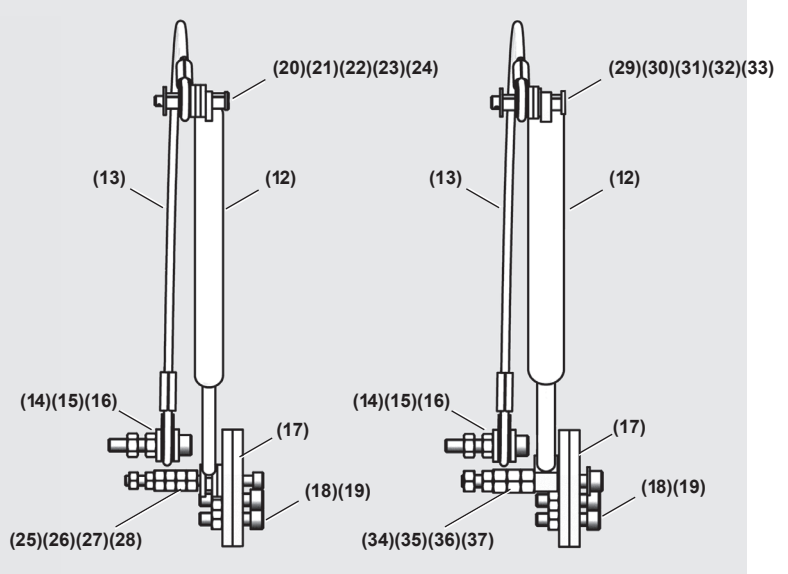

HOPPER DEVICE (GS S)
 GAS SPRING 700-1150N
 3-54105-C02

HOPPER DEVICE (GS L)
 GAS SPRING 1300-2100N
 3-54105-C02

P	SE	FR	DE	GB - DETAIL	SPECIFICATION	ART NO	Q	M	V
20	CYLINDBULT	BOULON CYL	ZYLINDERBO	CLEVIS PIN	B 8X55X3,2 ISO2341	9-41059	1	XX	GS S
21	BRICKA	RONDELLE	WASHER	WASHER	10.5X25X4 DIN7349 FZB	9-40117	3	XX	
22	BRICKA	RONDELLE	WASHER	WASHER	BRB 10,5 FZB	9-40031	1	XX	
23	GLIDLAGER	PALIER LISSE	GLEITLAGER	SLIDE BEARING	PCM 101210 M	9-60057	3	XX	
24	SAX PINNE	GOUPILLE F	STIFT	SPLIT PIN	ISO1234 2X20 FZB	9-41060	1	XX	
25	SKRUV	VIS	SCHRAUBE	SCREW	SHS MC6S 8X100	9-40111	1	XX	
26	MUTTER	ÉCROU	MUTTER	NUT	M6M M 8 FZB	9-40045	2	XX	
27	MUTTER	ÉCROU	MUTTER	NUT	M6M M 10 FZB	9-40030	3	XX	
28	BRICKA	RONDELLE	WASHER	WASHER	10.5X25X4 DIN7349 FZB	9-40117	3	XX	
29	CYLINDBULT	BOULON CYL	ZYLINDERBO	CLEVIS PIN	B10X55X3,2 ISO2341	9-41057	1	XX	GS L
30	BRICKA	RONDELLE	WASHER	WASHER	10.5X25X4 DIN7349 FZB	9-40117	2	XX	
31	BRICKA	RONDELLE	WASHER	WASHER	BRB 10,5 FZB	9-40031	1	XX	
32	GLIDLAGER	PALIER LISSE	GLEITLAGER	SLIDE BEARING	PCM 101210 M	9-60057	3	XX	
33	SAX PINNE	GOUPILLE F	STIFT	SPLIT PIN	ISO1234 3,2X20ST FZB	9-40946	1	XX	
34	SKRUV	VIS	SCHRAUBE	SCREW	SHS MC6S 10X100	9-40235	1	XX	
35	MUTTER	ÉCROU	MUTTER	NUT	M6M M 12 FZB	9-40207	3	XX	
36	MUTTER	ÉCROU	MUTTER	NUT	M6M M 10 FZB	9-40030	2	XX	
37	BRICKA	RONDELLE	WASHER	WASHER	BRB 10,5 FZB	9-40031	1	XX	

(XX = 30, 45, 60) (JACK = LINEAR ACTUATOR) (GS S = GAS SPRING, SMALL) (GS L = GAS SPRING L) (ALL GS = ALL GAS SPRINGS)

Safety, Hopper & Cutter housing

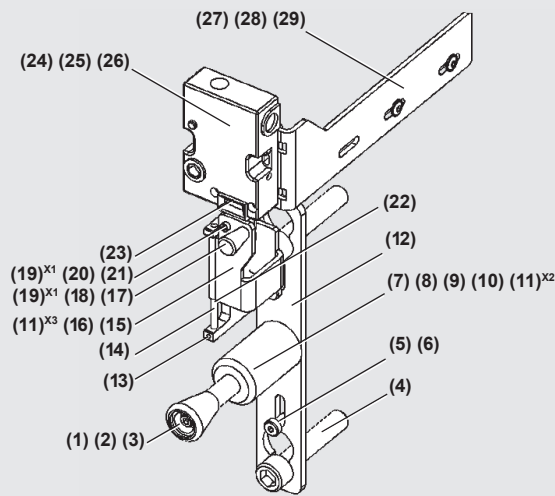

SAFETY DT / PT
2-54430-C02

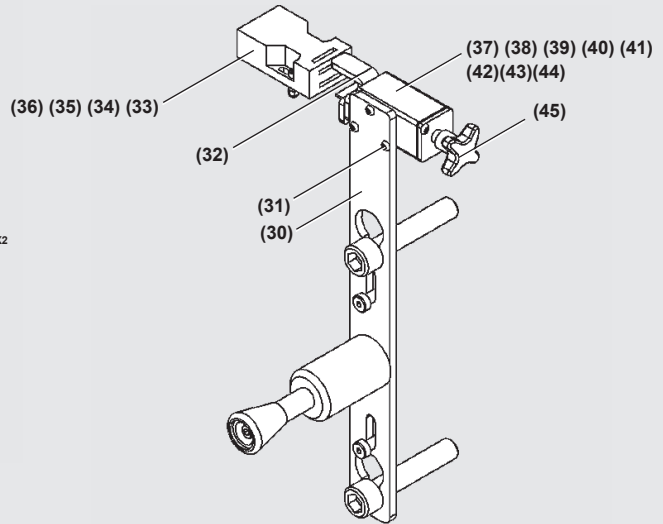

SAFETY SOLO
2-54575-C02

P	SE	FR	DE	GB - DETAIL	SPECIFICATION	ART NO	Q	M	V	
1	KNOPP	POIGNÉE	KNOPF	KNOB	WN 41 40-8	9-50681	1	XX	DT/PT, S	
2	SKRUV	VIS	SCHRAUBE	SCREW	SHS MC6S 8X40	9-40200	1			
3	HANDTAG	POIGNÉE	GRIFF	HANDLE	KNOB	8445937	1			
4	SKRUV	VIS	SCHRAUBE	SCREW	SHS MC6S 20X100	9-40583	2			
5	PASSKRUV	BOULON	PASSBOLZEN	FITTING BOLT	M 8 X 10 X 16MM	9-50745	2			
6	BRICKA	RONDELLE	SCHEIBE	WASHER	SPRING 23X10,2X0,9	9-40961	12			
7	HÅLLARE	SUPPORT	HALTER	HOLDER	SPRING HANDLE	8453401	1			
8	TRYCKFJÄDER	RESSORT PR	DRUCKFEDER	COMPRESSION SPRIN	DY=24,77 DT=2,16 LO	9-50697	1			
9	BRICKA	RONDELLE	SCHEIBE	WASHER	1X32X4 DIN 1441 FZB	9-40960	1			
10	LÅS	VERROU COM	SCHLOSS	LOCK	WASHERS FOR SHAFT	9-40944	1			
11	SKRUV	VIS VIS D'ARR	SCHRAUBE	SCREW	SHS MF6S 5X18	9-40611	5	XX	DT/PT	
							2	XX	S	
12	LÅSBLECK	LAME VERR	SCHLOSSBLE	LOCKING CLIP	SAFETY	8354400	1	XX	DT/PT	
13	STOPPSKRUV	VIS D'ARRÊT	ANSCHLSCHR	GRUB SCREW	SK6SS 5X6	9-40563	1			
14	AXEL	ARBRE	ACHSE	SHAFT	---	8453534	1			
15	SKYDD	PROTECTION	SCHUTZ	PROTECTION	LOCKING CLIP	8353531	1			
16	GÅNGJÄRN	CHARNIÈRE	SCHARNIER	HINGE	LOCKING CLIP	8353883	1			
17	KNOPP	POIGNÉE	KNOPF	KNOB	LN93 20-M5	9-50746	1			
18	SKRUV	VIS	SCHRAUBE	SCREW	SHS MC6S 5X25	9-40250	1			
19	BRICKA	RONDELLE	SCHEIBE	WASHER	BRB 5,3 FZB	9-40243	2			
20	MUTTER	ÉCROU	MUTTER	NUT	LOC-KING M 5	9-40267	1			
21	SKRUV	VIS	SCHRAUBE	SCREW	SHS MC6S 5X16	9-40115	1			
22	FJÄDRANDE T	RESSORT	FEDER	SPRUNG BOLT	GN614 D=6	9-50763	1			
							(XX = 30, 45, 60)	(DT/PT = DELTA TECH & POWER TECH)		(S = SOLO)

Safety, Hopper & Cutter housing

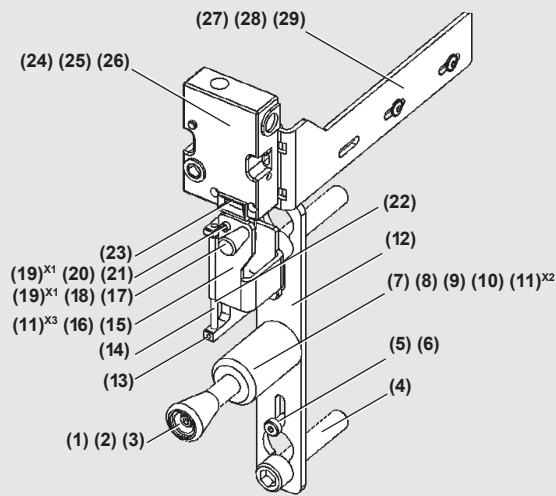

SAFETY DT / PT
2-54430-C02

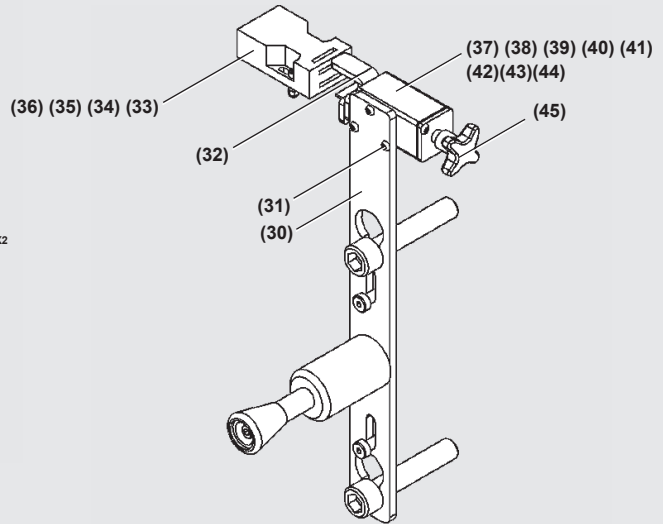

SAFETY SOLO
2-54575-C02

P	SE	FR	DE	GB - DETAIL	SPECIFICATION	ART NO	Q	M	V	
23	NYCKEL	CLÉ	SCHLÜSSEL	KEY	LAT GUARD MASTER	9-11649	1			
24	BRYTARE NYC	INTERUPTEUR	SCHALTER	SWITCH	TUMBLER LOCK TLS1-	9-93207	1			
25	SKRUV	VIS	SCHRAUBE	SCREW	SHS MC6S 5X22	9-40217	2			
26	SKRUV	VIS	SCHRAUBE	SCREW	SHS MC6S 5X35	9-40174	2	XX	DT/PT	
27	HÅLLARE	SUPPORT	HALTER	HOLDER	SWITCH	8353503	1			
28	BRICKA	RONDELLE	SCHEIBE	WASHER	KROSV	8453504	1			
29	SKRUV	VIS	SCHRAUBE	SCREW	SHS K6SF 8X16 10.9	9-40885	2			
30	LÅSBLECK	LAME VERR0	SCHLOSSBLE	LOCKING CLIP	---	8354576	1			
31	SKRUV	VIS	SCHRAUBE	SCREW	HS K6S 5X16	9-40796	3			
32	NYCKEL	CLÉ	SCHLÜSSEL	KEY	OPERATOR CLAMP SC	9-11003	1			
33	BRYTARE	INTERUPTUER	SCHALTER	SWITCH	AZ16-02 ZVRK	9-11002	1			
34	BRICKA	RONDELLE	SCHEIBE	WASHER	BRB 5,3 FZB	9-40243	4			
35	SKRUV	VIS	SCHRAUBE	SCREW	SHS MC6S 5X22	9-40217	2			
36	MUTTER	ÉCROU	MUTTER	NUT	LOC-KING M 5	9-40267	2			
37	FÄSTE	FIXATION	BEFESTIGUN	BRACKET	BREAKING SCREW	8353578	1	XX	S	
38	CYLINDER	CYLINDER	ZYLINDER	CYLINDER	KEY	8353775	1			
39	SKRUV	VIS	SCHRAUBE	SCREW	---	8353582	1			
40	BRICKA	RONDELLE	SCHEIBE	WASHER	---	8453583	1			
41	LOCK	COUVERCLE	DECKEL	COVER	---	8453584	1			
42	BRICKA	RONDELLE	SCHEIBE	LOCK WASHERS	FOR SHAFT DIA=8MM	9-41058	1			
43	SKRUV	VIS	SCHRAUBE	SCREW	SHS K6S 5X12	9-41050	2			
44	STOPPSKRUV	VIS ARRET	ANSCHLSHRA	GRUBSCREW	P6SS 6X12	9-40607	1			
45	STJÄRNVRED	POIGNÉE ÉTO	STERNGRIF	STAR KNOB	GN6335.1 E50-M10	9-50393	1			
							(XX = 30, 45, 60)	(DT/PT = DELTA TECH & POWER TECH)		(S = SOLO)

Cutter housing

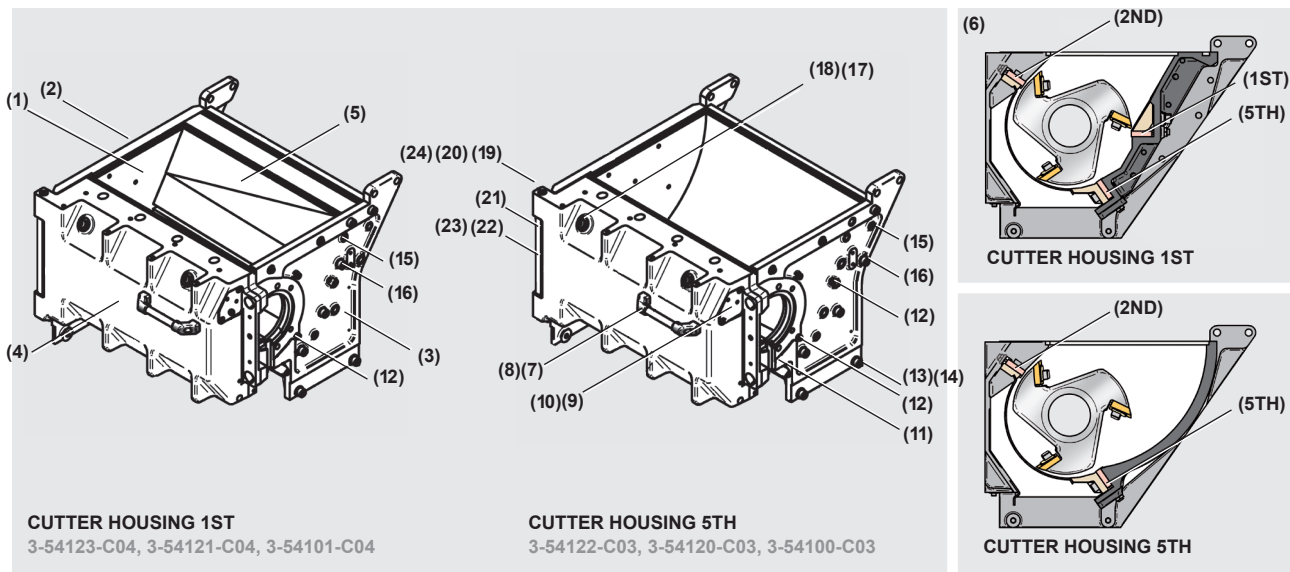

CUTTER HOUSING 1ST
3-54123-C04, 3-54121-C04, 3-54101-C04

CUTTER HOUSING 5TH
3-54122-C03, 3-54120-C03, 3-54100-C03

P	SE	FR	DE	GB - DETAIL	SPECIFICATION	ART NO	Q	M	V
1	SIDA INRE	CÔTÉ INTÉRI	SEITE INNERE	SIDE INNER	1ST	8254309	2	XX	1ST CU
					1ST HA	8454331	2	XX	1ST CU H
					5TH	8254308	2	XX	5TH CU
					5TH HA	8454332	2	XX	5TH CU H
2	SIDA V	CÔTÉ G	SEITE L	SIDE L	BLACK	8154352	1	XX	ALL
3	SIDA H	CÔTÉ D	SEITE R	SIDE R	BLACK	8154353	1	XX	
4	FRONTSIDA	CÔTÉ AVANT	VORDERSEITE	FRONTSIDE	BLACK	8154329	1	30	
5	BAKSIDA	CÔTÉ ARRIÈ	RÜCKSEITE	BACK SIDE	1ST, BLACK	8154326	1	45	1ST CU
						8154302	1	60	
						8154328	1	30	
					1ST HA, BLACK	8454370	1	30	1ST CU H
						8454372	1	45	
						8454374	1	60	
					5TH, BLACK	8154327	1	30	5TH CU
						8154324	1	45	
						8154300	1	60	
					5TH HA, BLACK	8454371	1	30	5TH CU H
						8454373	1	45	
						8454375	1	60	
6	STÖDLINJAL	RÈGLE D'APP	KLEMMLEISTE	SUPPORT RULE	1ST	8254317	1	30	1ST
						8253333	1	45	
						8253338	1	60	
					2ND	8354313	1	30	2ND
						8353334	1	45	
						8253387	1	60	
					5TH	8254312	1	30	5TH
						8254323	1	45	
						8254310	1	60	

(1ST CU = CUTTER HOUSING 1ST)
(1ST CU H = CUTTER HOUSING 1ST HARDENED)
(XX = 30, 45, 60)

(5TH CU = CUTTER HOUSING 5TH)
(5TH CU H = CUTTER HOUSING 5TH HARDENED)
(ALL = ALL VARIANTS)

(1ST = KNIFE POSITION 1ST)
(2ND = KNIFE POSITION 2ND)
(5TH = KNIFE POSITION 5TH)

Cutter housing

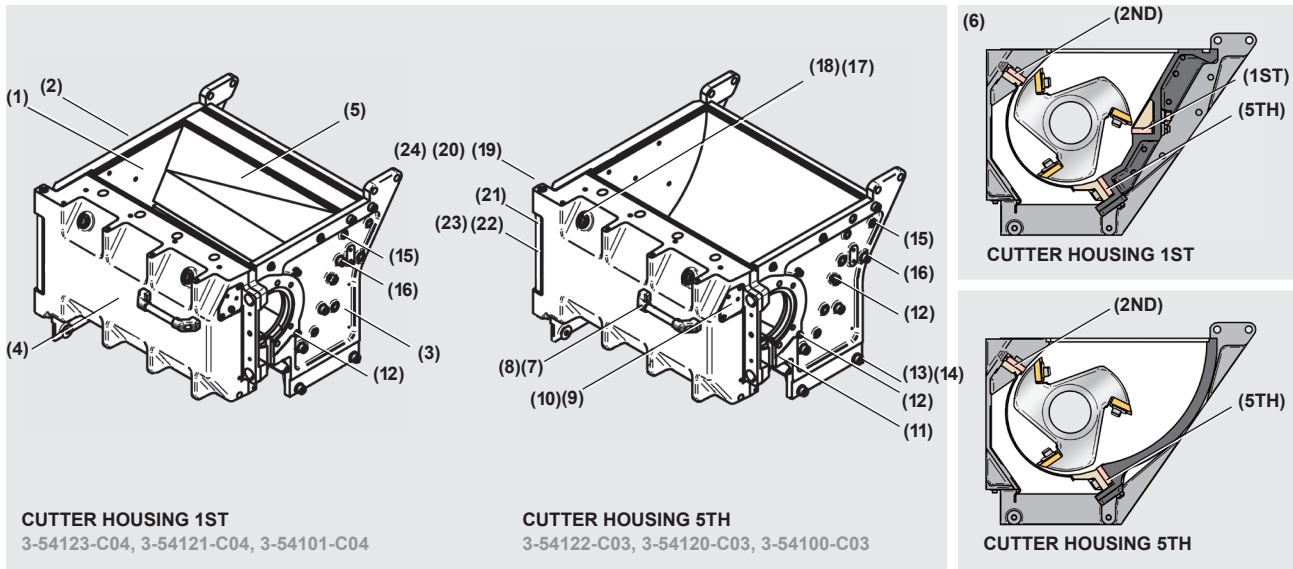

P	SE	FR	DE	GB - DETAIL	SPECIFICATION	ART NO	Q	M	V
7	HANDTAG	POIGNÉE	GRIFF	HANDLE	CLAMP WN428 20-200	9-50751	1	XX	ALL
8	SKRUV	VIS	SCHRAUBE	SCREW	SHS MC6S 8X20	9-40070	2	XX	
9	TÄCKPLÅT	PLAQUE REC	ABDECKPLAT	COVER PLATE	RIGHT	8354314	1	XX	
					LEFT	8354315	1	XX	
10	SKRUV	VIS	SCHRAUBE	SCREW	SHS MF6S 8X12 10.9	9-41053	4	XX	
11	SKRUV	VIS	SCHRAUBE	SCREW	SHS MF6S 10X20	9-40116	2	XX	
12	SKRUV	VIS	SCHRAUBE	SCREW	SHS M10X32 MC6S	8453629	10	XX	1ST CU
							12	XX	5TH CU
13	BRICKA	RONDELLE	SCHEIBE	WASHER	BRB 17,0	9-40035	4	XX	ALL
14	SKRUV	VIS	SCHRAUBE	SCREW	SHS MC6S 16X30 UNBR	9-40436	4	XX	
15	CYLINDR PIN	GOUPILLE CY	ZYLIND STIFT	PARALLELL PIN	INSIDE THREADED	9-50748	6	XX	1ST CU
							4	XX	5TH CU
16	SKRUV	VIS	SCHRAUBE	SCREW	SHS MC6S 16X40 12.9	9-41002	10	XX	1ST CU
							8	XX	5TH CU
17	SKRUV	VIS	SCHRAUBE	GRUBSCREW	T6SS 16X40	8453322	6	XX	1ST CU
							4	XX	5TH CU
18	MUTTER	ÉCROU	MUTTER	NUT	LOW ML6M M 16	9-40373	6	XX	1ST CU
							4	XX	5TH CU
19	GLIDLAGER	PALIER LISSE	GLEITLAGER	SLIDE BEARING	.PCM 202320 M	9-90583	5	XX	ALL
20	AXEL	ARBRE	ACHSE	SHAFT	HINGE FRONT SIDE	80069810	2	XX	
21	GÅNGJÄRN	CHARNIÈRE	SCHARNIER	HINGE	FRONT SIDE BLACK	80069851	1	XX	
22	CYLINDR PIN	GOUPILLE CY	ZYLIND STIFT	PARALLELL PIN	10X45 HARDENED	9-50747	2	XX	
23	SKRUV	VIS	SCHRAUBE	SCREW	SHS MC6S 16X45	9-40674	2	XX	
24	SKRUV	VIS	SCHRAUBE	SCREW	SHS MC6S 8X130	9-40791	2	XX	

(1ST CU = CUTTER HOUSING 1ST) (5TH CU = CUTTER HOUSING 5TH) (1ST = KNIFE POSITION 1ST)
 (1ST CU H = CUTTER HOUSING 1ST HARDENED) (5TH CU H = CUTTER HOUSING 5TH HARDENED) (2ND = KNIFE POSITION 2ND)
 (XX = 30, 45, 60) (ALL = ALL VARIANTS) (5TH = KNIFE POSITION 5TH)

Rotor

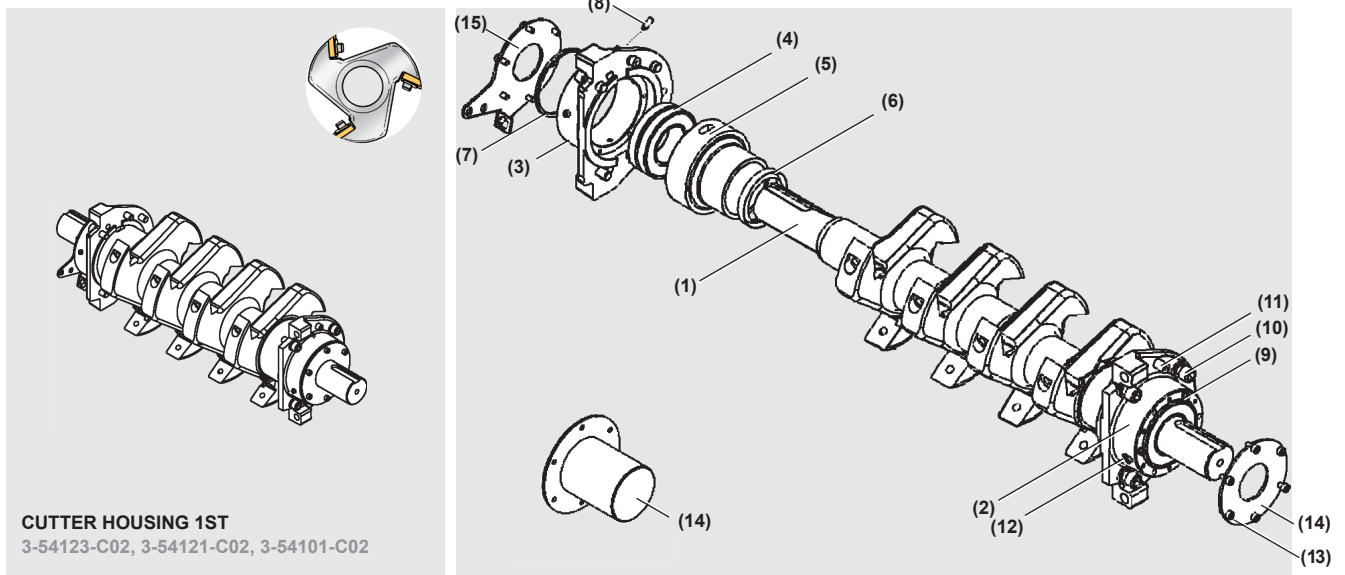

CUTTER HOUSING 1ST
3-54123-C02, 3-54121-C02, 3-54101-C02

P	SE	FR	DE	GB - DETAIL	SPECIFICATION	ART NO	Q	X	V
1	KUTTER	ROTOR	ROTOR	ROTOR	3BL CAST	8154344	1	30	3BL
						8154342	1	45	
						8154340	1	60	
2	LAGERHUS	BOÎTIER PALI	LAGER GEHÄ	BEARING HOUSING	RIGHT	8154354	1	XX	ALL
3	LAGERHUS	BOÎTIER PALI	LAGER GEHÄ	BEARING HOUSING	LEFT	8154359	1	XX	
4	LAGER	PALIER	LAGER	BEARING	BS2-2213-2CS	9-60237	2	XX	
5	LABYRINTRI	BAUGE	LABYRINTRIN	LABYRINTH RING	---	8354355	2	XX	
6	TÄTNINGSRI	BAGUE ÉTAN	DICHT RING	SEALING RING	CR 90X140X12	9-60233	2	XX	
7	RING	BAGUE	RING	RING	D=130/121X5 GUIDE	8453356	1	XX	
8	STOPPSKRUV	VIS D'ARRÊT	ANSCHLSCHR	GRUB SCREW	T6SS 8X22	9-41054	3	XX	
9	SKRUV	VIS	SCHRAUBE	SCREW	SHS MC6S 6X60	9-40450	6	XX	
10	SKRUV	VIS	SCHRAUBE	SCREW	SHS MC6S 16X40 12.9	9-41002	8	XX	
11	CYLINDR PIN	GOUPILLE CY	ZYLIND STIFT	PARALLELL PIN	INSIDE THREADED	9-50748	4	XX	
12	SKRUV	VIS	SCHRAUBE	SCREW	SHS MC6S 6X6	9-40722	2	XX	
13	SKRUV	VIS	SCHRAUBE	SCREW	SHS MC6S 8X16	9-40032	12	XX	
14	LAGERLOCK	CHAPEAU PAL	LAGERDECKE	BEARING COVER	RIGHT	8354357	1	XX	
						8354418	1	XX	WE
						8354357	2	XX	WEF
15	LAGERLOCK	CHAPEAU PAL	LAGERDECK	BEARING COVER	LEFT	8354358	1	XX	ALL

(XX = 30, 45, 60) (3BL = 3-BLADE ROTOR) (ALL = ALL VARIANTS)
(E = ENCLOSED GRANULATOR) (WE = WITHOUT ENCLOSURE) (WEF = WITHOUT ENCLOSURE BUT WITH FLYWHEEL)

Knives

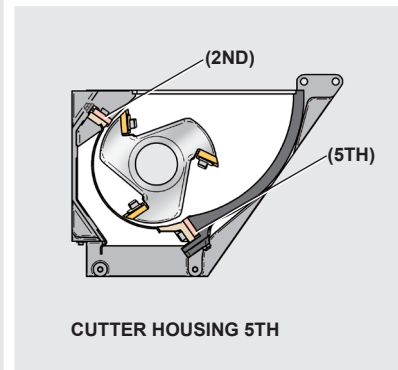
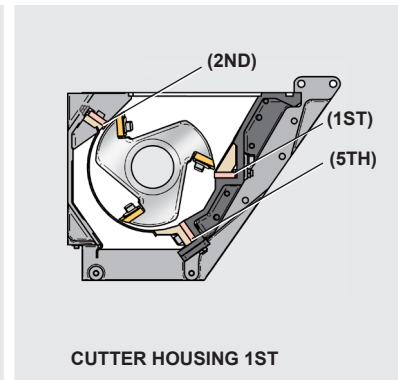
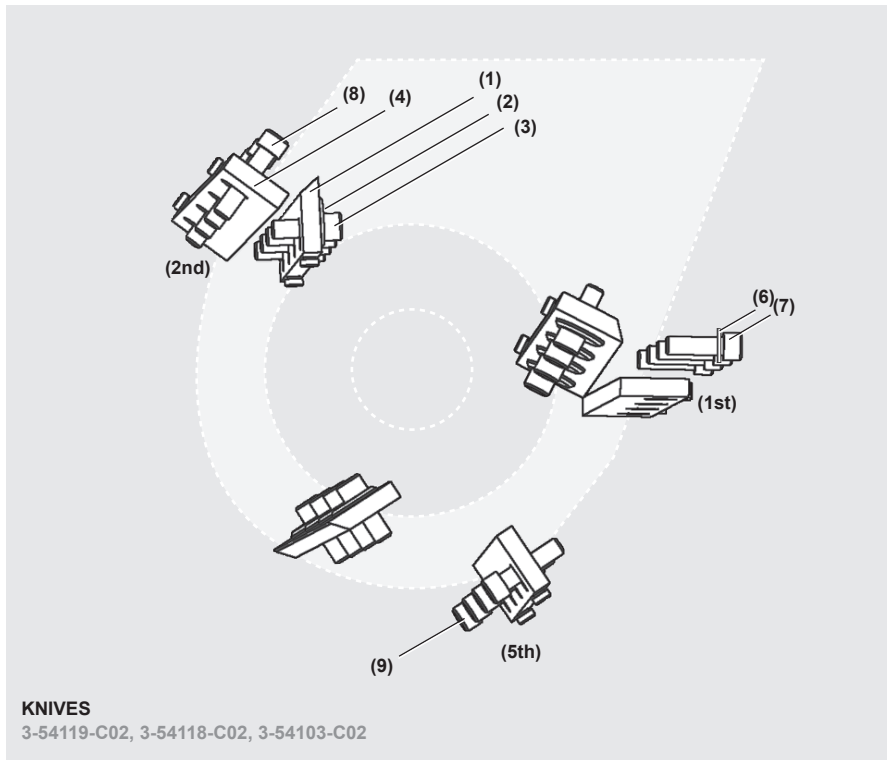

KNIVES
3-54119-C02, 3-54118-C02, 3-54103-C02

P	SE	FR	DE	GB - DETAIL	SPECIFICATION	ART NO	Q	X	V	
1-9	KNIVSATS	KIT COUTEAUX	MESSERSATZ	KNIFE KIT	COMPLETE KIT WITH: FIXED KNIVES, ROT KNIVES, WASHERS, SCREWS & DISTANCES.	MF354119-*** MF354118-*** MF354103-***	1 1 1	45 60 90	3BL	
1	KNIV ROT	COUTEAUX RO	ROTORMESSE	KNIFE ROT	---	8353368 8353364 8353360	3 3 3	30 45 60	ALL	
2	BRICKA	RONDELLE	SCHEIBE	WASHER	KNIFE ROTATING	8411835	6 9 12	30 45 60		
3	SKRUV	VIS	SCHRAUBE	SCREW	SHS MC6S 16X45 UNBR	9-41046	6 9 12	30 45 60		
4	KNIV FAST	COUTEAUX FIX	STATORMESS	KNIFE FIXED	---	8353370 8353366 8353362	1*** 1*** 1***	30 45 60		
5*	DISTANS	ENTRETOISE	ABSTANDSTÜ	DISTANCE	SUPPORT RULE	8354368 8353696 8353697	1 1 1	30 45 60		DU

-*** = ADD -12, -25 OR -125 (-12=1ST& 2ND) (-25=2ND & 5TH) (-125=1ST, 2ND & 5TH)

EXAMPLE: MF353118-12 = COMPLETE KNIFE KIT WITH SCREWS, WASHERS AND ROT KNIVES FOR 3-BL ROTOR, MODEL 60 AND FIXED KNIVES FOR KNIFE SEAT 1ST AND 2ND.

(XX = 30, 45, 60) (ALL = ALL VARIANTS)
(5* = DISTANCE "KNIFE DUMMY" IS NOT SHOWN IN FIGURE)
(1*** = ONE KNIFE PER KNIFE POSITION)
(10** = SUPPORT RULE IS NOT SHOWN IN FIGURE)

(1ST = KNIFE POSITION 1ST)
(2ND = KNIFE POSITION 2ND)
(5TH = KNIFE POSITION 5TH)
(DU = KNIFE DUMMY FITS ALL KNIFE POS)

Knives

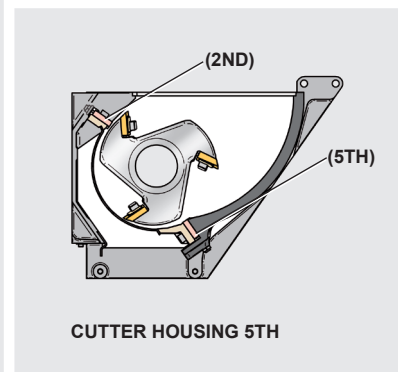
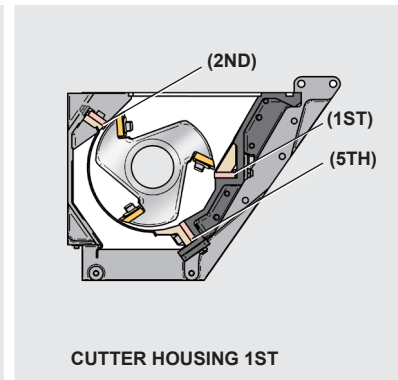
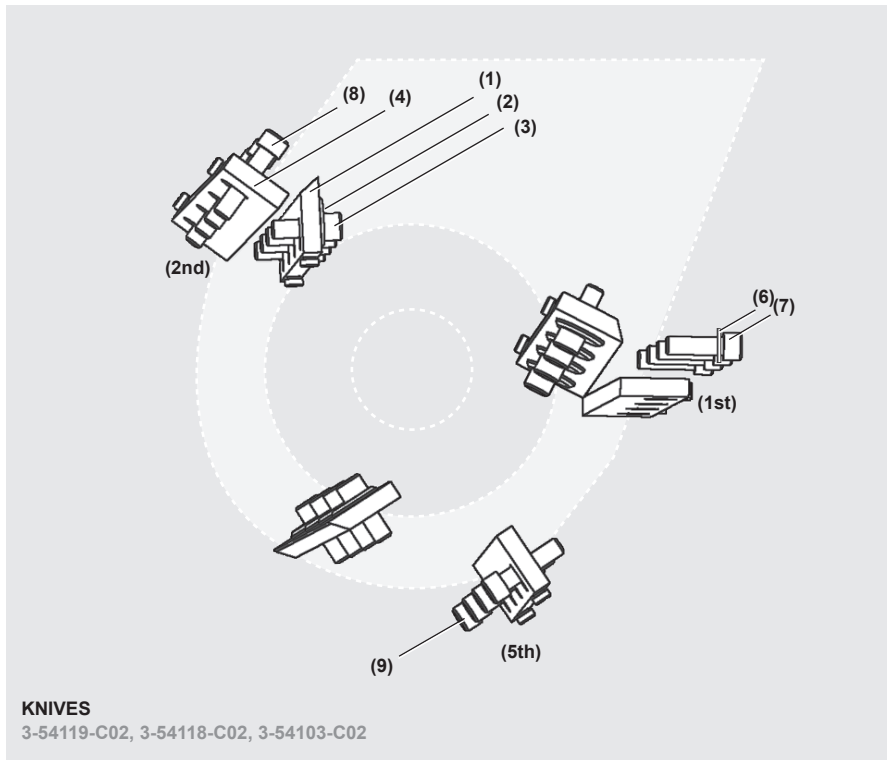

KNIVES
3-54119-C02, 3-54118-C02, 3-54103-C02

P	SE	FR	DE	GB - DETAIL	SPECIFICATION	ART NO	Q	X	V
6	BRICKA	RONDELLE	SCHEIBE	WASHER	HARDENED M16 FZV 69	9-40784	2	30	1ST
							3	45	
							4	60	
7	SKRUV	VIS	SCHRAUBE	SCREW	SHS MC6S 16X50 UNBR	9-40074	2	30	1ST
							3	45	
							4	60	
8	SKRUV	VIS	SCHRAUBE	SCREW	SHS MC6S 16X50 UNBR	9-40074	2	30	2ND
							3	45	
							4	60	
9	SKRUV	VIS	SCHRAUBE	SCREW	SHS MC6S 16X60 UNBR	9-40074	2	30	5TH
							3	45	
							4	60	
10**	STÖDLINJAL	RÈGLE D'APP	KLEMMLEIST	SUPPORT RULE	1ST	8254317	1	30	1ST
						8253333	1	45	
						8253338	1	60	
					2ND	8354313	1	30	2ND
						8353334	1	45	
						8253387	1	60	
					5TH	8254312	1	30	5TH
						8254323	1	45	
						8254310	1	60	

(XX = 30, 45, 60)
 (5* = DISTANCE "KNIFE DUMMY" IS NOT SHOWN IN FIGURE)
 (1*** = ONE KNIFE PER KNIFE POSITION)
 (10** = SUPPORT RULE IS NOT SHOWN IN FIGURE)

(1ST = KNIFE POSITION 1ST)
 (2ND = KNIFE POSITION 2ND)
 (5TH = KNIFE POSITION 5TH)
 (DU = KNIFE DUMMY FITS ALL KNIFE POS)

Screen box, Screen

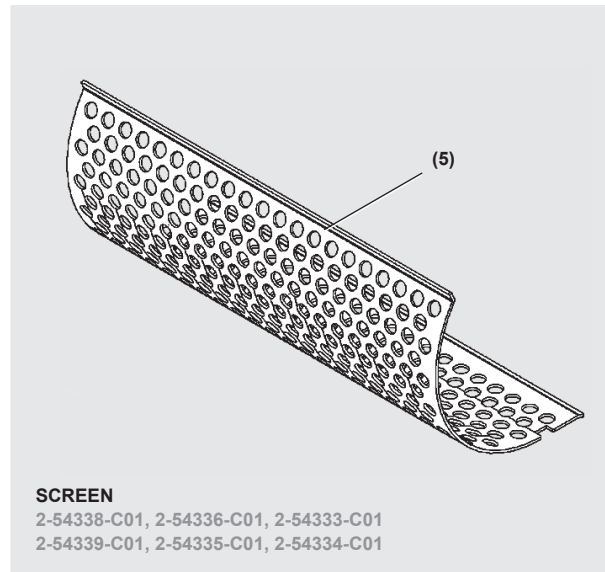
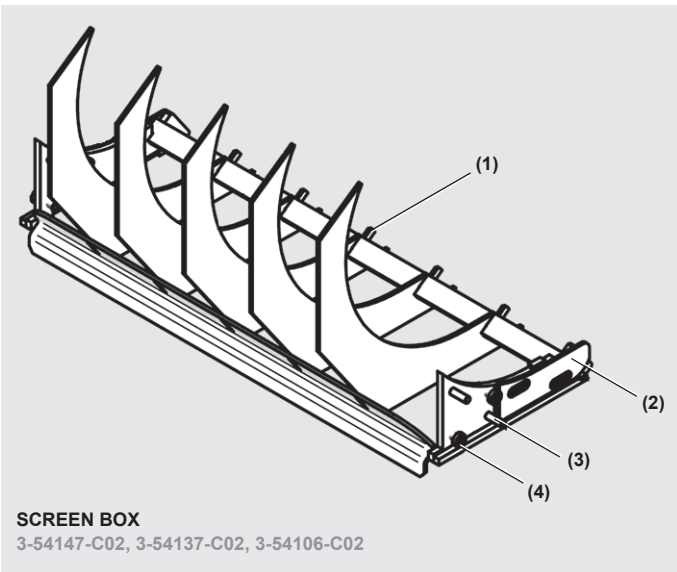

P	SE	FR	DE	GB - DETAIL	SPECIFICATION	ART NO	Q	M	V
1	GALLERLÅDA	BOÎTE DE TAM	SIEBKASTEN	SCREEN BOX	---	8154397	1	30	ALL
						8154383	1	45	
						8154444	1	60	
2	GALLERBÅGE	COURBE DE T	SIEBBOGEN	SCREEN BOW	OUTER LEFT	8354394	1	XX	ALL
					OUTER RIGHT	8354395	1	XX	
3	SPÄNNSTIFT	GOUPILLE SE	SPANNSTIFT	SPRING PIN	FRP 8 X 18 ISO8752	9-50767	2	XX	ALL
					FRP 8 X 32	9-50079	2	XX	
4	SKRUV	VIS	SCHRAUBE	SCREW	SHS K6S 10X18 ISO7380	9-41075	4	XX	ALL
5	GALLER	GRILLE	SIEB	SCREEN		8254338-YY	1	30	STD
						8254336-YY	1	45	
						8254333-YY	1	60	
						8254339-YY*	1	30	H
						8254335-YY*	1	45	
8254334-YY*	1	60							

(XX = 30, 45, 60) (STD = STANDARD PERFORMANCE) (H = HARDENED) (ALL = ALL VARIANTS)

(YY = SCREEN HOLE DIAMETER IN MM + TYPE OF SCREEN)

(YY* = HARDENED SCREEN, ADD "N" AFTER THE HOLE DIAMETER)

EXAMPLE: 8254338-08 = STANDARD SCREEN FOR G300-30 WITH 8 MM HOLES

EXAMPLE: 8254338-08TD11= OPEN AREA SCREEN FOR G300-30 WITH 8 MM HOLES

EXAMPLE: 8225439-08N = HARDENED SCREEN FOR G300-30 WITH 8 MM HOLES

-YY STANDARD SCREEN		
D	TD	OPEN %
04	6	40
05	8	35
06	9	40
08	12	40
10	15	40
12	17	45
17	26	39
25	39	38

-YY OPEN AREA SCREEN		
D	TD	OPEN %
04	5.5	48
05	7	45
06	8	50
08	11	48
10	14	46
12	16	51
17	24	45
25	36	44

Granule bin

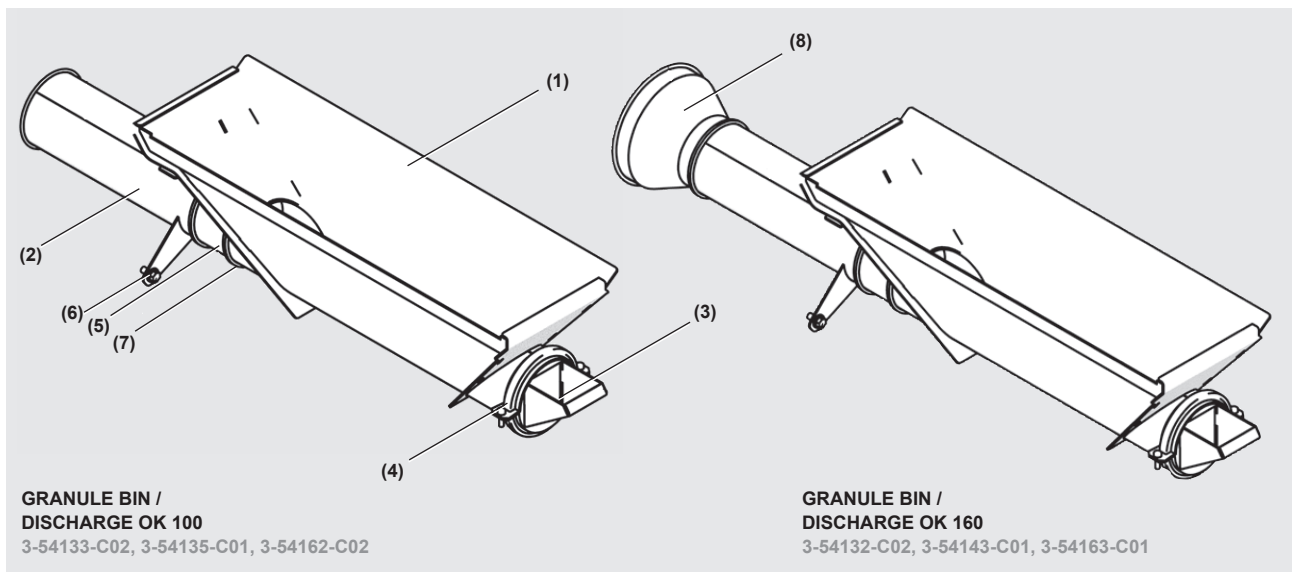

P	SE	FR	DE	GB - DETAIL	SPECIFICATION	ART NO	Q	M	V
1	GRANULATLÅD	BAC À GRANU	MAHLGUTKAS	GRANULE BIN	OK100	8154542	1	30	ALL
						8154473	1	45	
						8154548	1	60	
2	STOS UTLOPP	RACC SORTIE	STUTZEN, AU	FLANGE OUTLET	OK100	8354458	1	XX	OK100, D
						8354475	1	XX	OK100, F
						8354458	1	XX	OK160
3	LUFTINTAG	ENTRÉE D'AIR	LUFTEINLASS	AIR INLET	OK 100, BLACK	8353470	1	30	ALL
						8354467	1	45	
						8353470	1	60	
4	BULTKOPPL	BOULON ASS	BOLZEN KUPP	BOLT COUPLING	OK100	9-20729	2	XX	OK100
							3	XX	OK160
5	RÖR	TUYAU	ROHR	PIPE	OK100X60, BLACK	8453456	1	XX	ALL
6	SKRUV	VIS	SCHRAUBE	SCREW	TAPPING TAPTITE 8X16	9-40444	1	XX	
7	SNABBKOPPL	RACCORD RA	SCHNELLKUP	QUICK COUPLING	OK100	9-20415	1	XX	
8	ÖVERGÅNG	RÉDUCTION	ÜBERGANG	REDUCER	OK100-OK160 L=110 NOA	8417784	1	XX	OK160
(XX = 30, 45, 60) (OK100 = DISCHARGE WITH OUTLET PIPE Ø 100MM) (OK106 = DISCHARGE WITH OUTLET PIPE Ø 160MM) (ALL = ALL VARIANTS) (D = BLOWER DETACHED) (F = BLOWER FIXED)									

Transmission, Motor, Flywheel

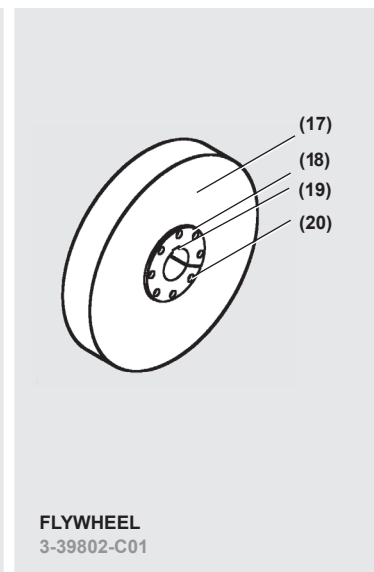
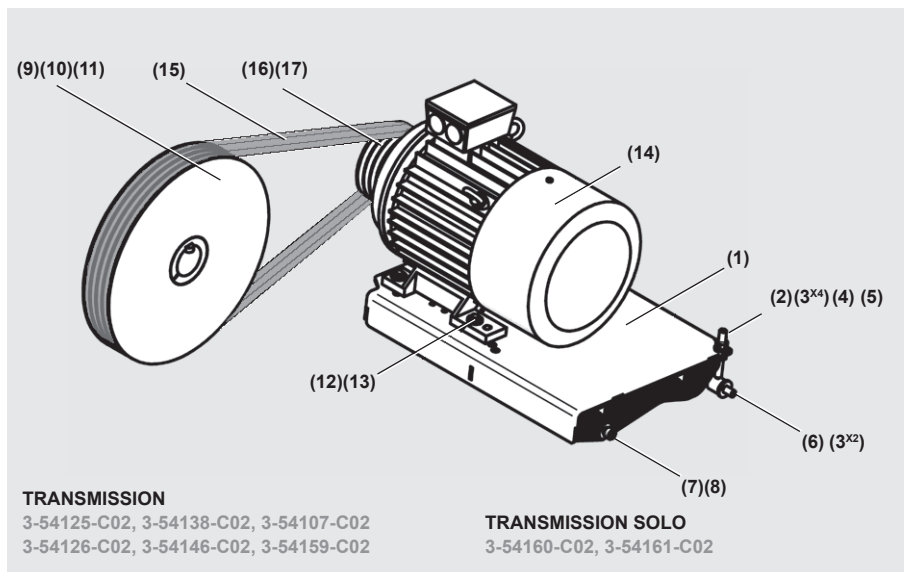

P	SE	FR	DE	GB - DETAIL	SPECIFICATION	ART NO	Q	X	V	
1	MOTORBRYG	SUPPORT MO	MOTORBEFES	□ □ MOUNTING	BRAKET BLACK	8254431	1	30	ALL	
						8254421	1	45		
						8254409	1	60		
2	REMSTRÄCK	TENDEUR CO	KEILRIEMSPA	BELT STRETCHER	L=140 BLACK	8353426	2	XX	ALL	
3	BRICKA	RONDELLE	SCHEIBE	WASHER	BRB 17,0	9-40035	6	XX		
4	MUTTER	ÉCROU	MUTTER	NUT	M6M M 16	9-40034	2	XX		
5	MUTTER	ÉCROU	MUTTER	NUT	LOC-KING M 16	9-40078	2	XX	ALL	
6	SKRUV	VIS	SCHRAUBE	SCREW	HHS M6S 16X70	9-40254	2	XX		
7	SKRUV	VIS	SCHRAUBE	SCREW	SHS MC6S 16X40 12.9	9-41002	2	XX		
8	BRICKA	RONDELLE	SCHEIBE	WASHER	NL16	9-40986	2	XX	DT/PT	
9	REMSKIVA	POULIE	RIEMENSCHAI	PULLEY	ROTOR SPB3 DW=360	8206306	1	XX		
					SPB 180-2/2517 T1 (ROTOR)	9-30315	1	45		S
10	KLÄMBUSSN	COUSSINET S	KLEMMBÜCH	FLANGE BUSHING	D=100/65 (ROTOR)	8215659	1	XX	DT/PT	
					2517 D65 (ROTOR)	9-30318	1	45	S	
11	KIL	CLAVETTE	KEIL	KEY	R 18X11X75 H7	9-50182	1	XX	ALL	
12	SKRUV	VIS	SCHRAUBE	SCREW	HHS M6S 12X50	9-40056	4	XX		
13	BRICKA	RONDELLE	SCHEIBE	WASHER	HARDENED M12 AMF DI	9-40060	4	XX		
14	MOTOR	MOTEUR	MOTOR	MOTOR		REFER TO MOTOR TABLE BELOW				
15	KILREM	COURROIE TR	KEILRIEMEN	V-BELT	XPB 1850 LW	9-30306	1	XX	A, B	DT/PT
					ROFLEX RE-X XPB 1800		9-30324	2	45	
16	REMSKIVA	POULIE	RIEMENSCHAI	PULLEY	MOTOR SPB3 DW=180	8306344	1	XX	50HZ,DT/PT	
					SPB 180-2/2517 T1 (MOTOR)	9-30311	1	45	50HZ,S	
					MOTOR SPB DW=160	8307526	1	XX	60HZ,DT/PT	
					SPB 150-2/2012 T2 (MOTOR)	9-30312	1	45	60HZ,S	

(XX = 30, 45, 60) (ALL = ALL VARIANTS) (DT/PT = DELTA TECH / POWER TECH) (S = SOLO)
(A,B,C,D,E,F = REFER TO MOTOR TABLE BELOW)

Transmission, Motor, Flywheel

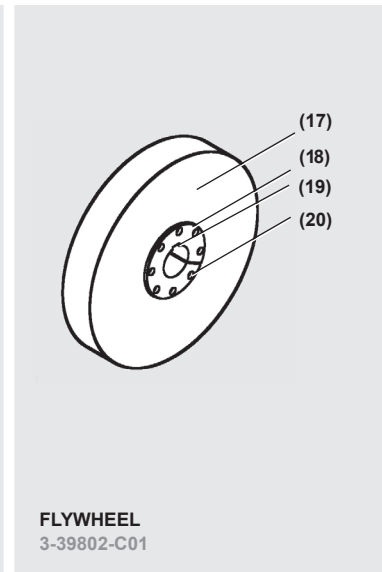
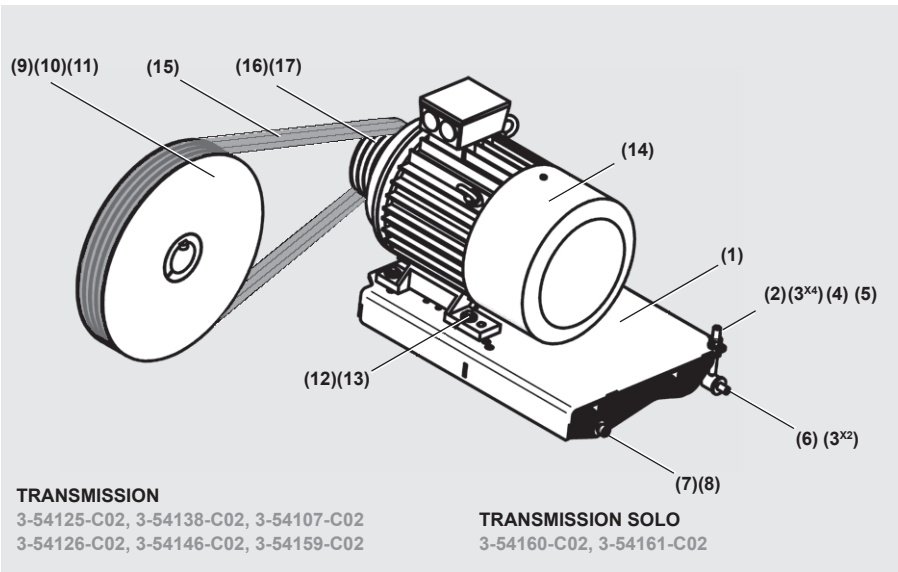

TRANSMISSION
3-54125-C02, 3-54138-C02, 3-54107-C02
3-54126-C02, 3-54146-C02, 3-54159-C02

TRANSMISSION SOLO
3-54160-C02, 3-54161-C02

FLYWHEEL
3-39802-C01

P	SE	FR	DE	GB - DETAIL	SPECIFICATION	ART NO	Q	X	V					
17	KLÄMBUSSN	COUSSINET S	KLEMMBÜCH	EXPANDING BUSHI	TAPER-LOCK TL2517 D=3	9-30118	1	XX	A, B					
					TAPER-LOCK TL2517 D=4	9-30119	1	XX	C, D					
					TAPER-LOCK TL2517 D=4	9-30225	1	XX	E, F					
					2517 D38 (MOTOR)	9-30317	1	45	A 50HZ					
					2012 D38 (MOTOR)	9-30319	1	45	A 60HZ					
18	SVÄNGHJUL	VOLANT MOT	SCHWUNGRA	FLYWHEEL	---	8206347	1	XX	FLYWHEEL					
					19	KLÄMBUSSN	COUSSINET S	KLEMMBÜCH		FLANGE BUSHING	D=100/65	8215659	1	XX
					20	KIL	CLAVETTE	KEIL		KEY	R 18X11X75 H7	9-50182	1	XX
					21	SKRUV	VIS	SCHRAUBE		SCREW	SHS MC6S 10X30 UNBR	9-40005	6	XX

(XX = 30, 45, 60) (DT/PT = DELTA TECH / POWER TECH) (S = SOLO) (A,B,C,D,E,, F = REFER TO MOTOR TABLE BELOW)

MOTOR TABLE	DT/PT 50 HZ (MF054125, MF054138, MF054107)			DT/PT 60HZ (MF054126, MF054146, MF054159)		
	1	2	3	1	2	3
	(200-219V / 50HZ)	(220-240V / 50HZ)	(380-420V / 50HZ)	(200-219V / 60HZ)	(440-480V / 60HZ)	(380-420V / 60HZ)
A (5.5 KW)	9-92830	9-11240	9-11171	9-92830	9-11171	9-92429
B (7.5 KW)	9-92388	9-11173	9-11172	9-92388	9-11172	9-92738
C (11 KW)	9-93809	9-11174	9-11163	9-93809	9-11163	9-93392
D (15 KW)	9-92497	9-92281	9-11181	9-92497	9-11181	9-92357
E (18.5 KW)	9-92840	9-10015N	9-10019N	9-92840	9-10019N	9-92868
F (22 KW)	9-92739	9-92866	9-11217	9-92739	9-11217	9-92869

MOTOR TABLE	SOLO 50 HZ (MF054160)			SOLO 60HZ (MF054161)		
	1	2	3	1	2	3
	(200-219V / 50HZ)	(220-240V / 50HZ)	(380-420V / 50HZ)	(200-219V / 60HZ)	(440-480V / 60HZ)	(380-420V / 60HZ)
A (7.5 KW)	9-12201	9-12202	9-12203	9-12207	9-12208	9-12209
B (15 KW)	9-12204	9-12205	9-12206	9-12210	9-12211	9-12212

EXAMPLE: SOLO MOTOR 15 KW & 220-240V/50 HZ = ART NO 9-12205

Safety, Transmission

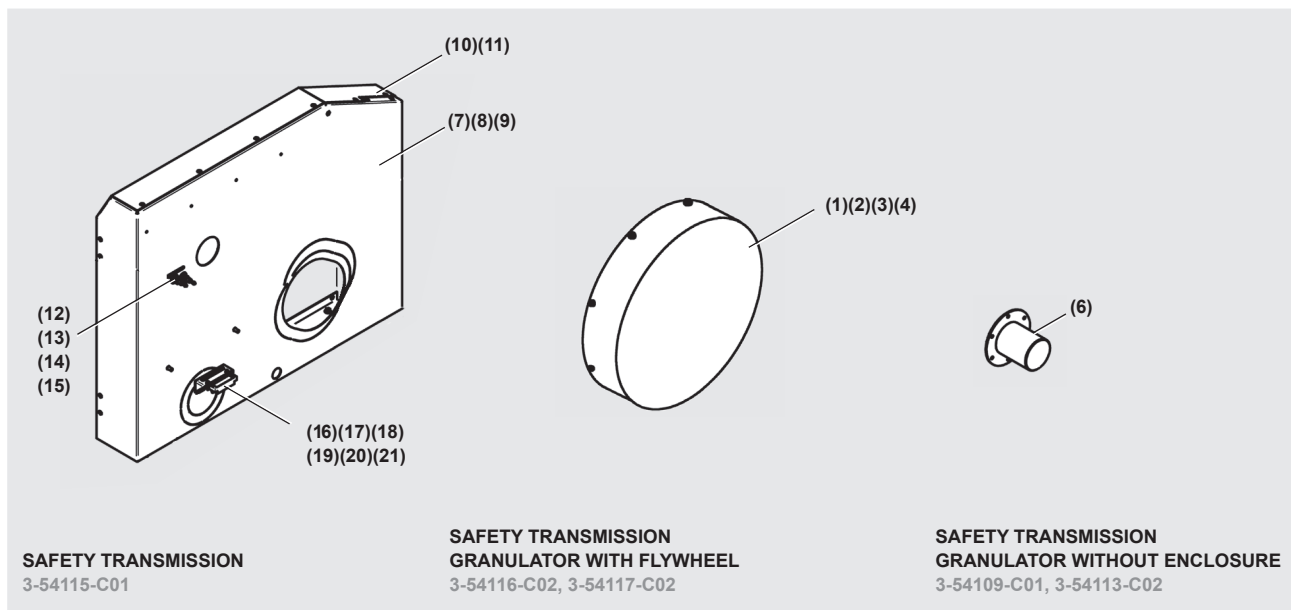

P	SE	FR	DE	GB - DETAIL	SPECIFICATION	ART NO	Q	M	V
1	SVÄNGHJULSS	PROTECTION	SCHUTZ SCH	FLYWHEEL GUARD	INNER & OUTER	80061205	1	XX	F
2	LAGER LOCK	PLAQUE	DECKEL LAGE	BEARING COVER	BLACK	8354357	1	XX	
3	SKRUV	VIS	SCHRAUBE	SCREW	TAPPING TAPTITE 8X16	9-40444	8	XX	
4	SKRUV	VIS	SCHRAUBE	SCREW	SHS MC6S 8X30	9-40007	6	XX	
6	SKYDD	PROTECTION	SCHUTZ	PROTECTION	SHAFT BLACK	8354418	1	XX	WE
7	KÅPA	CAPOT	HAUBE	COVER	L INNER AND OUTER	8254416	1	XX	ALL
8	SKRUV	VIS	SCHRAUBE	SCREW	TAPPING TAPTITE 8X16	9-40444	6	XX	
9	MUTTER	ÉCROU	MUTTER	NUT	BLIND RIVET M 8 STEEL	9-50750	26	XX	
10	KAPSLING	ENCAPSULAG	KAPSELUNG	ENCLOSURE		8254417	1	XX	
11	SKRUV	VIS	SCHRAUBE	SCREW	SHS K6SF 8X16 10.9	9-40885	22	XX	DT/PT
12	GIVARE	CAPTEUR	GEBER	TRANSMITTER	STAND STILL MONITO	8353431	1	XX	
13	SENSOR	SENSOR	SENSOR	SENSOR	IA12DSN04PO-3M	9-11758	2	XX	
14	SKRUV	VIS	SCHRAUBE	SCREW	SHS MF6S 8X20 10.9	9-41041	3	XX	
15	PLUGG	PLUG	PLUG	PLUG	IKPK 28-24 S	9-50727	2	30	SOLO
16	FÄSTE	FIXATION	BEFESTIGUN	BRACKET	SWITCH MAGNET, BLAC	8354419	1	XX	ALL
17	BRYTARE MAG	INTERUPTEUR	SCHALTER	SWITCH MAGNET	BNS 33-12Z	9-11727	1	XX	
18	BRYTARE MAG	INTERUPTEUR	SCHALTER	SWITCH MAGNET	FOR, BPS 33-2326	9-11728	1	XX	
19	SKRUV	VIS	SCHRAUBE	SCREW	SHS K6SF 8X16 10.9	9-40885	24	XX	
20	SKRUV	VIS	SCHRAUBE	SCREW	SHS MC6S 4X25	9-40638	4	XX	
21	MUTTER	ÉCROU	MUTTER	NUT	LOC-KING M 4 LOW	9-40315	4	XX	

(XX = 30, 45, 60) (F= FLYWHEEL) (WE = WITHOUT ENCLOSURE) (ALL = ALL VARIANTS) (DT/PT = DELTATECH & POWERTECH) (S = SOLO)

Safety, Enclosure

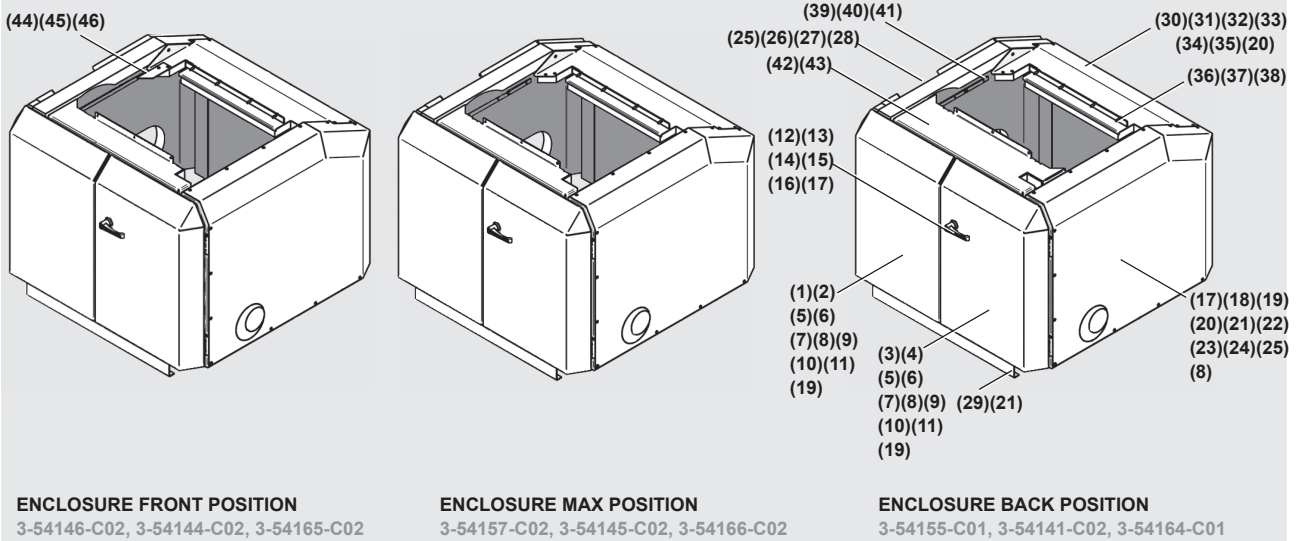

P	SE	FR	DE	GB - DETAIL	SPECIFICATION	ART NO	Q	M	V
1	DÖRR V	PORTE	TÜR L	DOOR L	---	8254607	1	30	ALL
						8254535	1	45	
						8254637	1	60	
2	BAKPLÅT V	PLAQUE ARR	BLECH HINT L	BACK PLATE L	DOOR L	8254607	1	30	ALL
						8254535	1	45	
						8254637	1	60	
3	DÖRR H	PORTE	TÜR R	DOOR R	---	8254607	1	30	ALL
						8254535	1	45	
						8254637	1	60	
4	BAKPLÅT H	PLAQUE ARR	BLECH HINT R	BACK PLATE R	DOOR R	8354610	1	30	ALL
						8354540	1	45	
						8354640	1	60	
5	GÅNGJÄRN	CHARNIÈRE	SCHARNIER	HINGE	STAINLESS STEEL BLA	9-50585	4	XX	ALL
6	LIST	BAGUETTE	LEISTE	LIST	CLIPS ART. NR. 53	9-70156	1	XX	
7	LIST	BAGUETTE	LEISTE	LIST	EPDM BLACK	9-90922	1	XX	
8	MUTTER	ËCROU	MUTTER	NUT	BLIND RIVET M 8 STEEL	9-50750	38	XX	
9	SKRUV	VIS	SCHRAUBE	SCREW	MONTAGE DRILWICKPH	9-40750	36	XX	ALL
10	ABSORBENT	ISOLATION	SCHALLSCHU	ABSORBER	DOOR FRONT	(3-54615)*	2	30	
						(3-54586)*	2	45	
						(3-54643)*	2	60	
11	ABSORBENT	ISOLATION	SCHALLSCHU	ABSORBER	DOOR BACK	(3-54616)*	2	30	
						(3-54587)*	2	45	
						(3-54644)*	2	60	
12	LÅS	VERROU	SCHLOSS	LOCK	DOOR	9-50756	1	XX	ALL
13	SKRUV	VIS	SCHRAUBE	SCREW	SHS MC6S 8X35	9-40126	1	XX	
14	DISTANS	ENTRETOISE	ABSTANDSTÜ	DISTANCE	LOCK DOOR	8345341	1	XX	
15	MUTTER	ËCROU	MUTTER	NUT	BLIND RIVET M 6 HEX	9-50550	7	XX	
16	SKRUV	VIS	SCHRAUBE	SCREW	SHS MC6S 6X30	9-40077	5	XX	
17	MUTTER	ËCROU	MUTTER	NUT	M6M M 6	9-40027	2	XX	

(XX = 30, 45, 60) (ALL = ALL VARIANTS) (B = BACK POSITION) (F = FRONT POSITION) (M= MAX POSITION) (* = REFER TO POS 47)

Safety, Enclosure

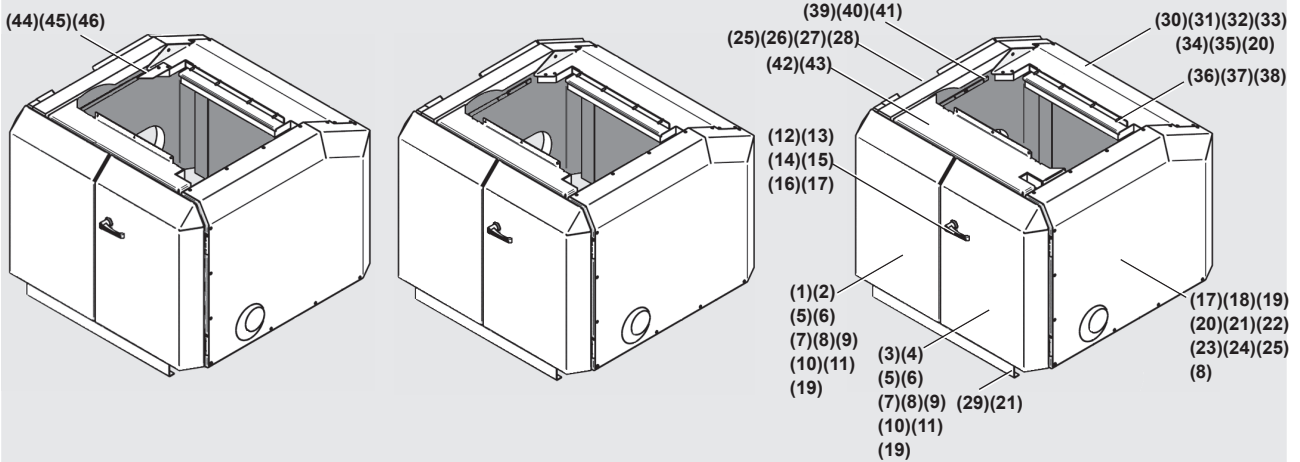

ENCLOSURE FRONT POSITION
3-54146-C02, 3-54144-C02, 3-54165-C02

ENCLOSURE MAX POSITION
3-54157-C02, 3-54145-C02, 3-54166-C02

ENCLOSURE BACK POSITION
3-54155-C01, 3-54141-C02, 3-54164-C01

P	SE	FR	DE	GB - DETAIL	SPECIFICATION	ART NO	Q	M	V
18	KÁPA	CAPOT	HAUBE	COVER	R BLACK	8254520	1	XX	ALL
19	KAPSLING	ENCAPSULAG	KAPSELUNG	ENCLOSURE	COVER R	8254521	1	XX	
20	SKRUV	VIS	SCHRAUBE	SCREW	SHS K6SF 8X16 10.9	9-40885	49	XX	
21	SKRUV	VIS	SCHRAUBE	SCREW	TAPPING TAPTITE 8X16	9-40444	13	XX	
22	ABSORBENT	ISOLATION	SCHALLSCHU	ABSORBER	COVER R FRONT	(3-54579)*	1	XX	
23	ABSORBENT	ISOLATION	SCHALLSCHU	ABSORBER	COVER R TOP	(3-54580)*	1	XX	
24	ABSORBENT	ISOLATION	SCHALLSCHU	ABSORBER	COVER R SIDE	(3-54582)*	1	XX	
25	ABSORBENT	ISOLATION	SCHALLSCHU	ABSORBER	COVER R BACK	(3-54581)*	2	XX	
26	ABSORBENT	ISOLATION	SCHALLSCHU	ABSORBER	COVER L FRONT	(3-54583)*	1	XX	ALL
27	ABSORBENT	ISOLATION	SCHALLSCHU	ABSORBER	COVER L TOP	(3-54584)*	1	XX	
28	ABSORBENT	ISOLATION	SCHALLSCHU	ABSORBER	COVER L SIDE	(3-54585)*	1	XX	
29	BOTTENPLÁT	PLAQUE FON	BODENBLECH	BOTTOM PLATE	---	8354621	1	30	
						8354538	1	45	
						8354642	1	60	
30	KÁPA	CAPOT	HAUBE	COVER	BACK	8254613	1	30	ALL
						8254537	1	45	
						8254641	1	60	
31	HANDTAG	GRIFFE	GRIFFE	HANDLE	P2-53 SOUTHCO	9-50757	2	XX	
32	LIST	BAGUETTE	LEISTE	LIST	SEALING/CLIPS	9-70040	1	XX	
33	LIST	BAGUETTE	LEISTE	LIST	CLIPS ART. NR. 53	9-70156	1	XX	
34	ABSORBENT	ISOLATION	SCHALLSCHU	ABSORBER	COVER BACK UPPER	(3-54617)*	1	30	
						(3-54588)*	1	45	
						(3-54645)*	1	60	
35	ABSORBENT	ISOLATION	SCHALLSCHU	ABSORBER	COVER BACK LOWER	(3-54618)*	1	30	
						(3-54589)*	1	45	
						(3-54646)*	1	60	
36	TÄTNING	SEALING	DICHTUNG	SEALING	BACK PIECE, BLACK	8354614	1	30	ALL
						8354503	1	45	
						8353528	1	60	
37	LIST	BAGUETTE	LEISTE	LIST	EPDM BLACK	9-90922	1	XX	
38	SKRUV	VIS	SHRAUBE	SCREW	SHS MC6S 8X25	9-40097	4	XX	

(XX = 30, 45, 60) (ALL = ALL VARIANTS) (B = BACK POSITION) (F = FRONT POSITION) (M= MAX POSITION) (* = REFER TO POS 47)

Safety, Enclosure

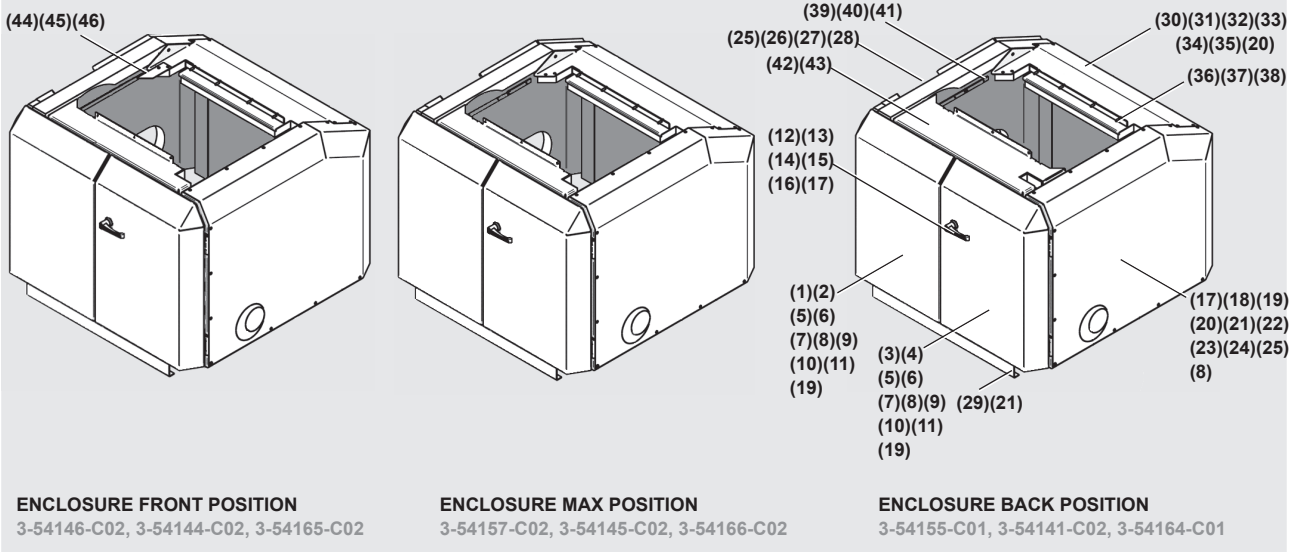

P	SE	FR	DE	GB - DETAIL	SPECIFICATION	ART NO	Q	M	V
39	HÅLLARE	SUPPORT	HALTER	HOLDER	LIST	8354524	2	XX	ALL
40	LIST	BAGUETTE	LEISTE	LIST	EPDM BLACK	9-90922	1	XX	
41	POP-NIT	RIVET	NIET	POP-RIVET	AL PRESSURE TIGHT	9-40623	8	XX	
42	DISTANS	ENTRETOISE	ABSTANDSTÜ	DISTANCE	HOPPER	8254611	1	30	B
						8253672	1	45	
						8253527	1	60	
						8254612	1	30	F, M
						8254504	1	45	
43	ABSORBENT	ISOLATION	SCHALLSCHU	ABSORBER	DISTANCE	(3-54619)*	1	30	B
						(3-54590)*	1	45	
						(3-53660)*	1	60	
44	PLÅT	PLAQUE	PLATTE	SIDE PLATE	SEALING BACK, BLACK	8453479	2		F
45	SKRUV	VIS	SCHRAUBE	SCREW	SHS K6S 6X14	9-40800	4	XX	
46	MUTTER	ECROU	MUTTER	NUT	BLIND RIVET M 6 STEEL	9-50749	4		
47	ABSORBENT	ISOLATION	SCHALLSCHU	ABSORBER	KIT FRONT & BACK	8354510	1	30	ALL
						8354511	1	45	
						8354512	1	60	
					KIT SIDE	8354513	1	XX	

(XX = 30, 45, 60) (ALL = ALL VARIANTS) (B = BACK POSITION) (F = FRONT POSITION) (M= MAX POSITION) (* = REFER TO POS 47)

Safety, Electrical cabinet

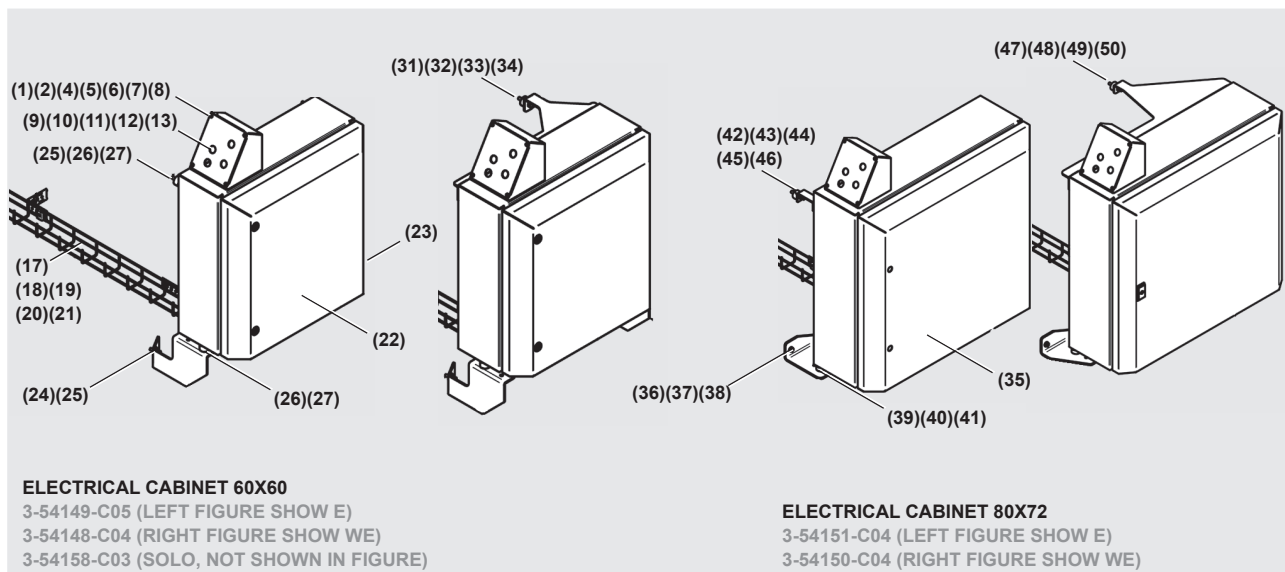

P	SE	FR	DE	GB - DETAIL	SPECIFICATION	ART NO	Q	M	V
1	MANÖVERPAN	PANN COMMA	BEDIENPULT	OPERATING PANEL	ELECTRICAL COM	8453467	1	XX	DT/PT
2	MANÖVERPAN	PANN COMMA	BEDIENPULT	OPERATING PANEL	ELECTRICAL COM	8353465	1	XX	
4	SKRUV	VIS	SCHRAUBE	SCREW	SHS SHS MC6S 5X10	9-40071	6	XX	
5	MUTTER	ÉCROU	MUTTER	NUT	BLIND RIVET M 5 STEEL	9-50247	4	XX	
6	SKRUV	VIS	SCHRAUBE	SCREW	SHS K6S 5X16	9-40796	4	XX	
7	SKYLT	PLAQUE	SCHILD	SIGN	FRAME M225-ST-X	9-12106	1	XX	
8	SKYLT	PLAQUE	SCHILD	SIGN	M22-XST	9-12107	1	XX	
9	NÖDSTOPP	ARR	NOT-AUS	EMERGENCY STOP	M22-PV	9-12025	1	XX	
10	TRYCKKNAPP		TASTE	PUSH-BUTTON	LAMP M22-DL-W-X1	9-12026	1	XX	
11	TRYCKKNAPP		TASTE	PUSH-BUTTON	M22-D-S-X0	9-12027	1	XX	
12	TRYCKKNAPP		TASTE	PUSH-BUTTON	LAMP M22-DL-B	9-12173	1	XX	
13	ADAPTER	ADAPTER	ADAPTER	ADAPTER	AUX BLOCK M22-A	9-12028	4	XX	
14	AUX BLOCK	AUX BLOCK	AUX BLOCK	AUX BLOCK	M22-K01	9-12029	4	XX	
15	AUX BLOCK	AUX BLOCK	AUX BLOCK	AUX BLOCK	M22-K10	9-12030	2	XX	
16	AUX BLOCK LA	AUX BLOCK LA	AUX BLOCK LA	AUX BLOCK LAMP	M22-LED-W	9-12031	2	XX	
17	KABELSTEGE	SUPP KABL	KABELHALTE	CABLE LADDER	(3-54460)	9-11461	1	30	
					(3-54456)	9-11461	1	45	
					(3-45501)	9-11461	1	60	
18	KABELSTEGE	SUPP CABL	KABELHALTE	CABLE LADDER	JOINT B2	9-11464	2	XX	
19	KABELSTEGE	SUPP CABLE	KABELHALTE	CABLE LADDER	ANGLE B27	9-11466	2	XX	
20	SKRUV	VIS	SCHRAUBE	SCREW	TAPPING TAPTITE 8X16	9-40444	2	XX	
21	SKRUV	VIS	SCHRAUBE	SCREW	KIT CABLE LADDER	9-11469	2	XX	

(XX = 30, 45, 60)
 (ALL = ALL VARIANTS)

(60X60 = ELECTRICAL CABINET 600X600X265)
 (80X72 = ELECTRICAL CABINET 800X720X290)
 (DT/PT = DELTATECH / POWERTECH)

(E = ENCLOSED GRANULATOR)
 (WE = GRANULATOR WITHOUT ENCLOSURE)
 (S = SOLO)

Safety, Electrical cabinet

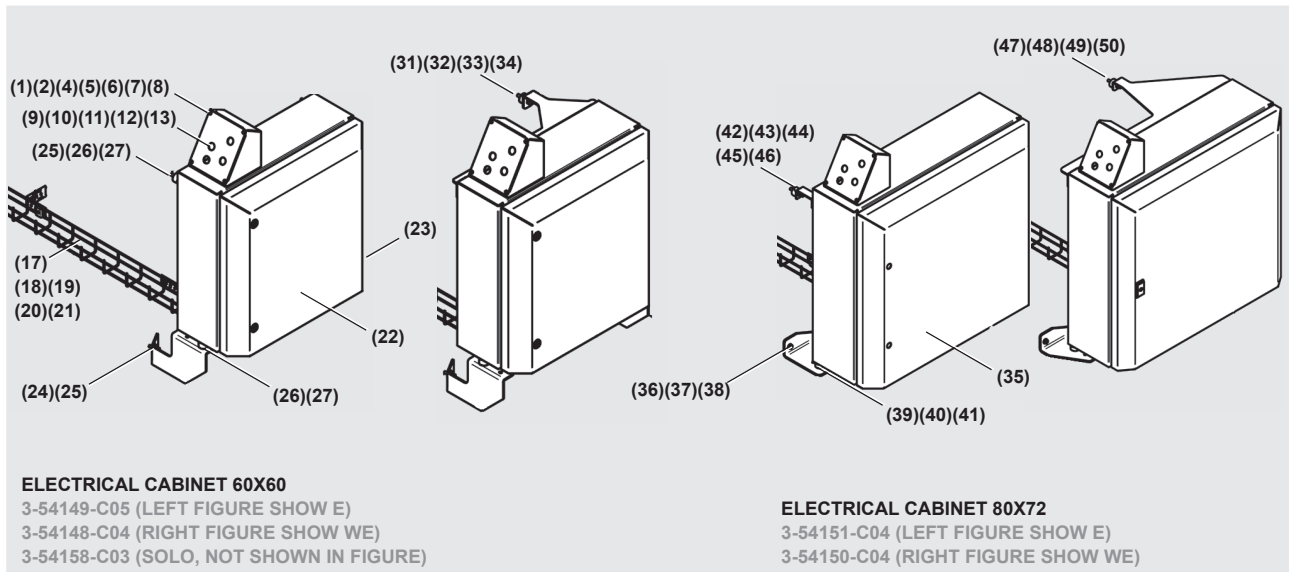

P	SE	FR	DE	GB - DETAIL	SPECIFICATION	ART NO	Q	M	V
22	TOMKAPSLING	ENCAPSULAG	KAPSELUNG	CUBICLE	600X600X265		1	XX	60X60, DT
					600X600X210		1	45	60X60, S
23	FÄSTE	FIXATION	BEFESTIGUN	BRACKET	ELECTRICAL CAB (RIGHT)	8353463	1	XX	60X60
24	FÄSTE	FIXATION	BEFESTIGUN	BRACKET	ELECTRICAL CAB (LEFT)	8353462	1	XX	
25	SKRUV	VIS	SCHRAUBE	SCREW	TAPPING TAPTITE 8X16	9-40444	4	XX	
26	DÄMPARE	AMORTISSEU	DÄMPFER	DAMPER	D=30 X 20 M8X20	9-90571	2	XX	
27	MUTTER	ÉCROU	MUTTER	NUT	LOC-KING M 8	9-40317	4	XX	
28	MUTTER	ÉCROU	MUTTER	NUT	BLIND RIVET M 8 STEEL	9-50276	2	XX	60X60 E
29	DÄMPARE	AMORTISSEU	DÄMPFER	DAMPER	D=30 X 20 M8X20	9-90571	2	XX	
30	MUTTER	ÉCROU	MUTTER	NUT	LOC-KING M 8	9-40317	2	XX	
31	FÄSTE	FIXATION	BEFESTIGUN	BRACKET	ELECTRICAL CAB. BLAC	8354468	1	XX	60X60 WE
32	MUTTER	ÉCROU	MUTTER	NUT	LOC-KING M 8	9-40317	3	XX	
33	SKRUV	VIS	SCHRAUBE	SCREW	SHS K6S 8X20	9-40662	2	XX	
34	DÄMPARE	AMORTISSEU	DÄMPFER	DAMPER	D=30 X 20 M8X20	9-90571	1	XX	
35	TOMKAPSLING	ENCAPSULAG	KAPSELUNG	CUBICLE	800X72000X290		1	XX	80X80, DT
36	FÄSTE	FIXATION	BEFESTIGUN	BRACKET	ELECTRICAL CAB. BLAC	8354438	1	XX	
37	SKRUV	VIS	SCHRAUBE	SCREW	TAPPING TAPTITE 8X16	9-40444	2	XX	
38	SKRUV	VIS	SCHRAUBE	SCREW	SHS MK6SF 10X40	9-41056	2	XX	
39	DÄMPARE	AMORTISSEU	DÄMPFER	DAMPER	D=30 X 20 M8X20	9-50754	2	XX	
40	MUTTER	ÉCROU	MUTTER	NUT	LOC-KING M 8	9-40317	2	XX	
41	SKRUV	VIS	SCHRAUBE	SCREW	SHS MF6S 8X12 10.9	9-41053	2	XX	
42	FÄSTE	FIXATION	BEFESTIGUN	BRACKET	ELECTRICAL CAB. BLAC	8353619	2	XX	80X80 E
43	MUTTER	ÉCROU	MUTTER	NUT	BLIND RIVET M 8 STEEL	9-50276	2	XX	
44	SKRUV	VIS	SCHRAUBE	SCREW	SHS K6S 8X20	9-40662	2	XX	
45	MUTTER	ÉCROU	MUTTER	NUT	LOC-KING M 8	9-40317	4	XX	
46	DÄMPARE	AMORTISSEU	DÄMPFER	DAMPER	D=30 X 20 M8X20	9-90571	2	XX	
47	FÄSTE	FIXATION	BEFESTIGUN	BRACKET	ELECTRICAL CAB. BLAC	8354469	1	XX	60X60 WE
48	MUTTER	ÉCROU	MUTTER	NUT	LOC-KING M 8	9-40317	3	XX	
49	SKRUV	VIS	SCHRAUBE	SCREW	SHS K6S 8X20	9-40662	2	XX	
50	DÄMPARE	AMORTISSEU	DÄMPFER	DAMPER	D=30 X 20 M8X20	9-90571	1	XX	

(XX = 30, 45, 60)
 (ALL = ALL VARIANTS)

(60X60 = ELECTRICAL CABINET 600X600X265)
 (80X72 = ELECTRICAL CABINET 800X720X290)
 (DT/PT = DELTATECH / POWERTECH)

(E = ENCLOSED GRANULATOR)
 (WE = GRANULATOR WITHOUT ENCLOSURE)
 (S = SOLO)

Body

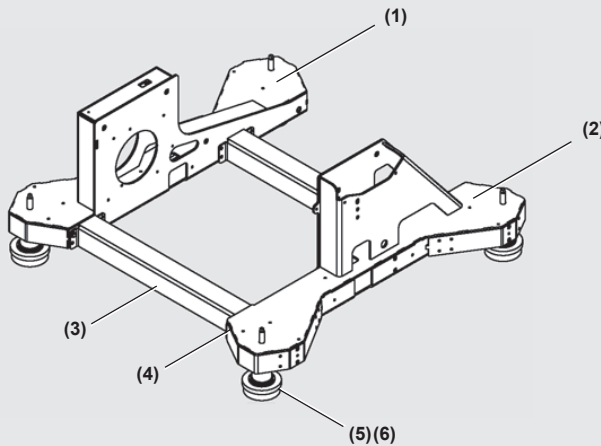

BODY MACHINE SHOE / WHEELS
3-54127-C02, 3-54140-C02, 3-54110-C02

P	SE	FR	DE	GB - DETAIL	SPECIFICATION	ART NO	Q	M	V
1	STATIV	BÂTI	GESTELL	STAND	L BLACK	8254401	1	XX	ALL
2	STATIV	BÂTI	GESTELL	STAND	R BLACK	8254406	1	XX	
3	STAG	ETAI	STREBE	SUPPORT	STAND, BLACK	8354429	2	30	ALL
						8354420	2	45	
						8253412	2	60	
4	SKRUV	VIS	SCHRAUBE	SCREW	TAPPING TAPTITE 8X16	9-40444	8	XX	
5	MASKINSKO	SEMELLE	MASCHFUSS	MACHINE SHOE	SUNNE SIZE 2	9-50308	4	XX	MS, MSL
6	DISTANS	ENTRETOISE	ABSTANDSTÜ	DISTANCE	MACHINE SHOE, BLACK	8453413	4	XX	MS
					D=60X72 MACHINE SHOE	8454767	4	XX	MSL
					CASTOR, BLACK	8453416	4	XX	AW
7	MUTTER	ÉCROU	MUTTER	NUT	LOC-KING M 12	9-40059	4	XX	
8	BRICKA	VIS	SCHRAUBE	SCREW	BRB 13,0	9-40155	4	XX	AW
9	SKRUV	VIS	SCHRAUBE	SCREW	HHS M6S 12X80	9-40627	4	XX	
10	HJUL	ROUE	RAD	CASTOR	D=100 FIXED 107565	9-50766	4	XX	WF
					SD4-100-101	9-50056	4	XX	WM
					D=100 FIXED 107565	9-50766	2	XX	WM+F
					SD4-100-101	9-50056	2	XX	

(XX = 30, 45, 60) (ALL = ALL VARIANTS) (MS = MACHINE SHOE) (MSL = MACHINE SHOE LOW)
 (WF= WHEELS FIXED) (WM = WHEELS MOVABLE) (WM+F = WHEELS FRONT MOVABLE BACK FXED) (WA = ALL WHEELS)

Options

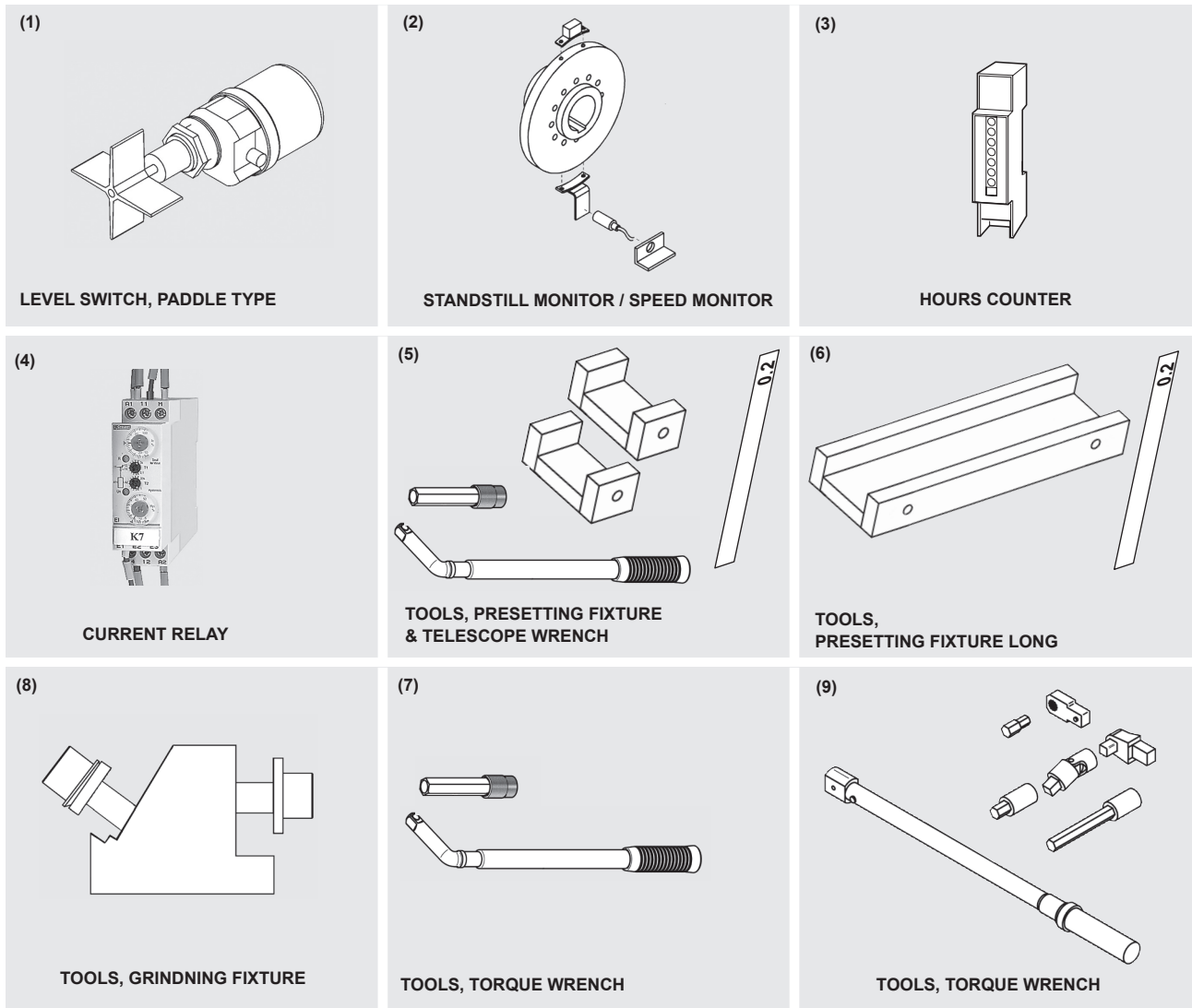

P	SE	FR	DE	GB - DETAIL	SPECIFICATION	ART NO	Q	M
1	NIVÁVAKT	INDIC. NIV	NIVÁWÄCHT	LEVEL INDICATOR	PADDLE SWITCH	*	1	
2	STILLES.VAK	INDIC. ARRET	STILL.WÄCH	STAND STILL WA	----	*	1	
3	TIMRÄKNARE	COMPT. HOU	STUNDENZÄH	HOURS COUNTER	----	*	1	
4	STRÖMRELÄ	RELAJ SÉLEC	STROMRELAJ	CURRENT RELAY	CROUZET	*	1	
5	VERKTYG	OUTIL	WERKZEUG	TOOLS	TELESCOPE WRENCH & PRESETTING FIXTURE, SHORT	MF353113	1	
6	VERKTYG	OUTIL	WERKZEUG	TOOLS	PRESETTING FIXTURE, L=570	MF353700	1	
					PRESETTING FIXTURE, L=870	MF353732	1	
7	VERKTYG	OUTIL	WERKZEUG	TOOLS	TELESCOPE WRENCH	MF353152	1	
8	VERKTYG	OUTIL	WERKZEUG	TOOLS	GRINDING FIXTURE, SF350 260	MF353745	1	
9	VERKTYG	OUTIL	WERKZEUG	TOOLS	TORQUE WRENCH, KIT	MM353213	1	

* WHEN ORDERING THIS DETAIL : SPECIFY GB-DETAIL AND SPECIFICATION + THE SERIAL NO OF YOUR GRANULATOR.

Material transport

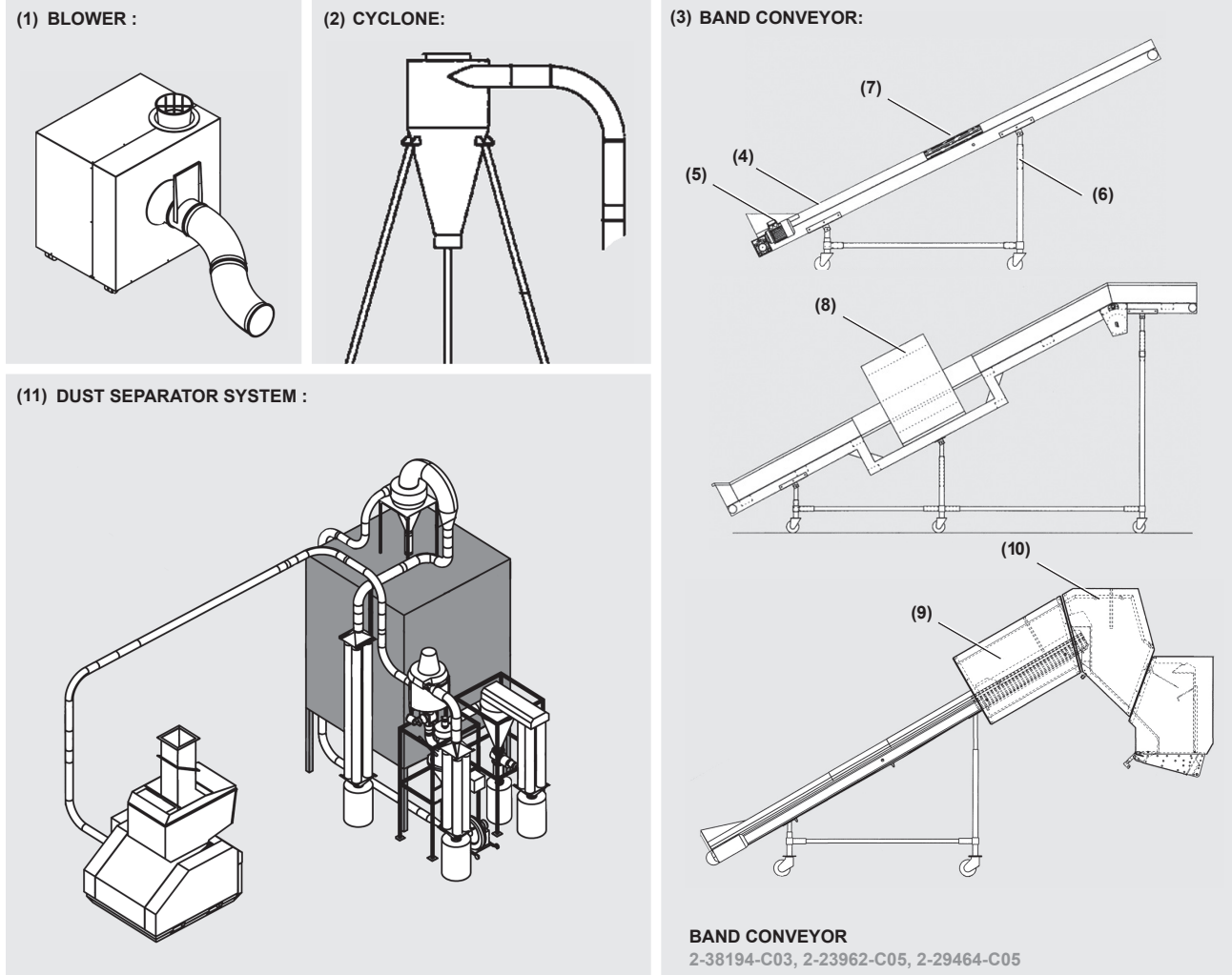

P	SE	FR	DE	GB - DETAIL	SPECIFICATION	ART NO	Q	-X
1	FLÅKT	VENTILATEUR	GEBLÄSE	BLOWER COMPLETE	F7, F15, F25	REFER TO PAGE 9:28		
2	CYKLON	CYCLONE	CYKLON	CYCLONE	AX7.5 AX12 AX16	*	1	AX
3	BANDTRANS	CONV BAND	BANDFÖRED	BAND CONV COMPLET	B300 B450 B600	*	1	B
4	BAND	BAND	BAND	BAND	BAND CONVEYOR	*	1	
5	MOTOR	MOTEUR	MOTOR	MOTOR	BAND CONVEYOR	*	1	
6	STATIV	FONDATION	GESTELL	STAND	BAND CONVEYOR	*	1	
7	MET DETEKT	DÉT MÉTAL	MET DETEKT	METAL DETECTOR	AREA	*, **	1	
8	MET DETEKT	DÉT MÉTAL	MET DETEKT	METAL DETECTOR	TUNNEL	*, **	1	
9	LJUDFÄLLA	SILENCIEUX	SCHALLHAUB	SOUND TRAP		*	1	
10	INLOPP	ENTRÉE	EINLASS	INLET		***	1	
11	DAMMSEP SY	FILTR POUSS	STAUBFILTER	DUST SEPARATOR SYS	TRACS, DS400, TP2119, TP2111	** ** ** **	1	DS

(U = BLOWER) (B = BAND CONVEYOR) (DS = DUST SEPARATOR SYSTEM)

* WHEN ORDERING THIS DETAIL SPECIFY: GB-DETAIL AND SPECIFICATION + THE SERIAL NO OF YOUR GRANULATOR.

** BEFORE ORDERING SPARE PARTS TO THIS DETAIL, PLEASE REFER TO THE SEPARATE INSTRUCTION MANUAL.

*** BEFORE ORDERING THIS DETAIL PLEASE REFER TO PAGE 9:1 "HOPPER" AND PAGE 9:2 "FLAPS".

Blower

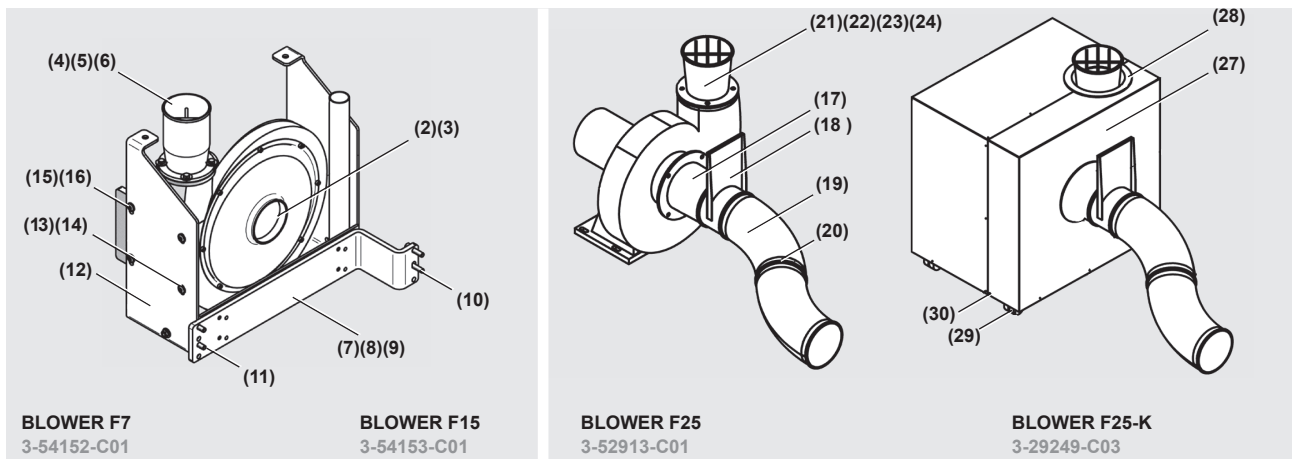

P	SE	FR	DE	GB - DETAIL	SPECIFICATION	ART NO	Q	V
1	FLÄKT	VENTILATEUR	BLASER	BLOWER	F7, F15, F25	REFER TO TABLE BELOW		
2	STOS	RACCORD	STUTZEN	FLANGE	INL F7-D=101 L=20	8330267	1	F7, F15
3	SKRUV	VIS	SCHRAUBE	SCREW	SHS MC6S 6X16	9-40039	8	
4	STOS	RACCORD	STUTZEN	FLANGE	OUTL F7-OK100 L=160	8313138	1	F7
					OUTL F15-OK100 L=150	8310332	1	F15
5	SKRUV	VIS	SCHRAUBE	SCREW	HHS M6S 8X20	9-40426	4	F7, F15
6	BRICKA	RONDELLE	SCHEIBE	WASHER	BRB 8,4 DIN-9021 Y	9-40592	4	
7	FÄSTE	FIXATION	BEFESTIGUN	BRACKET	BLOWER	8354505	1	
8	SKRUV	VIS	SCHRAUBE	SCREW	SHS MC6S 10X16	9-40201	4	
9	BRICKA	RONDELLE	SCHEIBE	WASHER	BRB 10,5 FZB	9-40031	4	
10	SKRUV	VIS	SCHRAUBE	SCREW	SHS MC6S 10X40 UNBR	9-40004	2	
11	SKRUV	VIS	SCHRAUBE	SCREW	SHS MF6S 10X30	9-40347	2	
12	HÅLLARE	SUPPORT	HALTER	HOLDER	BLOWER BLACK	8354506	1	
13	HÅLLARE	SUPPORT	HALTER	HOLDER	BLOWER F7/F15 BLACK CHR	8424655	1	
14	SKRUV	VIS	SCHRAUBE	SCREW	SHS MK6SF 10X40	9-41056	4	
15	MUTTER	ÉCROU	MUTTER	NUT	LOC-KING M 10	9-40015	2	
16	BRICKA	RONDELLE	SCHEIBE	WASHER	BRB 10,5 FZB	9-40031	2	
17	STOS	RACCORD	STUTZEN	FLANGE	INL F25-OK160 L=150	8208679	1	F25, F25-K
18	SPJÄLL	REGULATEUR	DROSSEL	SLIDING DAMPER	OK160 L=100	9-20197	1	
19	RÖR	TUYAU	ROHR	PIPE BEND	BEND OK160 45 DEG NOAB	8417781	2	
20	SNABBKOPPL	RACCORD RA	SCHNELLKUP	QUICK COUPLING	OK160	9-20107	4	
21	STOS	RACCORD	STUTZEN	FLANGE	OUTL F25-OK160 L=160	8208684	1	
22	SKRUV	VIS	SCHRAUBE	SCREW	HHS M6S 12X40	9-40022	8	
23	MUTTER	ÉCROU	MUTTER	NUT	M6M M 12 FZB	9-40207	8	
24	BRICKA	RONDELLE	SCHEIBE	WASHER	BRB 13,0	9-40155	12	
25*	KONTAKTDON	CONTACTEUR	NETZSTECKE	CONNECTOR	6-POLE CABLE HOOD	9-11006	1	F25-K
26*	KONTAKTDON	CONTACTEUR	NETZSTECKE	CONNECTOR	6-POLE HIGH CHASSIS	9-11032	1	
27	BULLERHUV	CAPOT ANTI	SCHALLDÄMP	SOUND HOOD	F25	8206036	1	
28	HJUL	ROUE	RAD	CASTOR	D=50 MM 41050002015	9-50427	4	
29	TÄTNINGSRIN	JOINT D'ÉTAN	DICHTUNGSRI	SEALING RING	PRESSED 230/130X4	9-70153	2	
30	SKRUV	VIS	SCHRAUBE	SCREW	MONTAGE DRILWICKPH4,8X16	9-40750	20	

MOTOR TABLE		1	2	3	4	5
		(200-220V / 50HZ)	(200-220V / 60HZ)	(380V / 60HZ)	(220-420V / 50HZ) (380-420V / 50HZ) (655-724V / 50HZ)	(440-480V / 60HZ)
A	F7	9-20877	9-20878	9-92187	9-920206	9-92828
A	F15	9-20879	9-20880	9-92136	9-20421	9-92829
A	F25	9-20881	9-20882	9-92312	9-20210	

We're Here to Help

Conair has made the largest investment in customer support in the plastics industry. Our service experts are available to help with any problem you might have installing and operating your equipment. Your Conair sales representative also can help analyze the nature of your problem, assuring that it did not result from misapplication or improper use.

Additional manuals and prints for your Conair equipment may be ordered through the Customer Service or Parts Department for a nominal fee.

Most manuals can be downloaded free of charge from the product section of the Conair website.

www.conairgroup.com

How to Contact Customer Service

To contact Customer Service personnel, call:



NOTE: Normal operating hours are 8:00 am - 5:00 pm EST. After hours emergency service is available at the same phone number.

From outside the United States, call: 814-437-6861

You can commission Conair service personnel to provide on-site service by contacting the Customer Service Department. Standard rates include an on-site hourly rate, with a one-day minimum plus expenses.

Before You Call...

If you do have a problem, please complete the following checklist before calling Conair:

- Make sure you have all model, control type from the serial tag, and parts list numbers for your particular equipment. Service personnel will need this information to assist you.
- Make sure power is supplied to the equipment.
- Make sure that all connectors and wires within and between control systems and related components have been installed correctly.
- Check the troubleshooting guide of this manual for a solution.
- Thoroughly examine the instruction manual(s) for associated equipment, especially controls. Each manual may have its own troubleshooting guide to help you.

Equipment Guarantee

Conair guarantees the machinery and equipment on this order, for a period as defined in the quotation from date of shipment, against defects in material and workmanship under the normal use and service for which it was recommended (except for parts that are typically replaced after normal usage, such as filters, liner plates, etc.). Conair's guarantee is limited to replacing, at our option, the part or parts determined by us to be defective after examination. The customer assumes the cost of transportation of the part or parts to and from the factory.

Performance Warranty

Conair warrants that this equipment will perform at or above the ratings stated in specific quotations covering the equipment or as detailed in engineering specifications, provided the equipment is applied, installed, operated and maintained in the recommended manner as outlined in our quotation or specifications.

Should performance not meet warranted levels, Conair at its discretion will exercise one of the following options:

- Inspect the equipment and perform alterations or adjustments to satisfy performance claims. (Charges for such inspections and corrections will be waived unless failure to meet warranty is due to misapplication, improper installation, poor maintenance practices or improper operation.)
- Replace the original equipment with other Conair equipment that will meet original performance claims at no extra cost to the customer.
- Refund the invoiced cost to the customer. Credit is subject to prior notice by the customer at which time a Return Goods Authorization Number (RGA) will be issued by Conair's Service Department. Returned equipment must be well crated and in proper operating condition, including all parts. Returns must be prepaid.

Purchaser must notify Conair in writing of any claim and provide a customer receipt and other evidence that a claim is being made.

Warranty Limitations

Except for the Equipment Guarantee and Performance Warranty stated above, Conair disclaims all other warranties with respect to the equipment, express or implied, arising by operation of law, course of dealing, usage of trade or otherwise, including but not limited to the implied warranties of merchantability and fitness for a particular purpose.