

Automatic Cutting for Large or High Density Extruded Products

Conair TS Series Up-Cut Saws offer heavy-duty cutting performance for larger, thicker extrusions that cannot be effectively cut with fly knife cutters.

The TS Traveling Saw, moves along with the process speed to cut pipe or profiles exacting to lengths with a carbide-tipped circular saw blade that rises from below the moving table. The operation is fully shielded to prevent injury and operates fully automatic.



Model TS-524

Follows the Process for Accuracy

Quality materials and workmanship go into every TS Saw. The combination of heavy-duty, steel-welded design and construction offers you the most reliable saw operation with the least amount of maintenance.

The cutting motor on the TS Saw is direct drive eliminating belts, reducing maintenance and allowing for the highest blade speeds for faster cycle times. Carbide tipped blades provide prolonged durability and resistance to product melting. Application specific blade styles are also available from Conair to optimize cutting of any type of extruded material.

An integrated, heavy-duty linear bearing system provides table top travel, driven by a precision servo motor that easily matches table motion to line speed.

Standard table travel is 20 and 24 inches {508 and 610 mm}. Longer table travel is available as an option.

▶ Reduced machine maintenance

A heavy-duty, precision servo system provides smooth and consistent table top movement.

▶ Precision cut lengths

Optional servo table travel with planetary reducers and a heavy-duty timing belt eliminates costly secondary operations, offers extreme cut-to-length repeatability and eliminates pneumatic adjustments for table travel.

▶ Increased productivity

The simplified arbor motor design reduces maintenance and increases blade rotation allowing faster line speeds. Blade speed is matched to blade diameter selection.

▶ Wide-open access

TS Saws feature access door panels for easy servicing. A NEMA-12 electrical enclosure with rotary lockable disconnect, a table top blade guard and a blade shroud design for ease of vacuum dust/chip removal are standard features.

▶ Easy to navigate touchscreen

Front-mounted touchscreen control allows start and stop control adjust blade travel, cutting speed and clamping pressure from one convenient location.

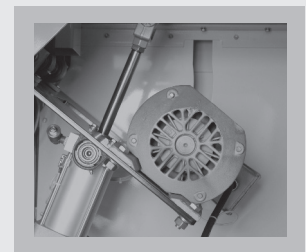
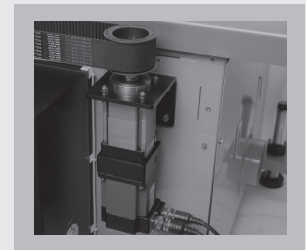

Specifications

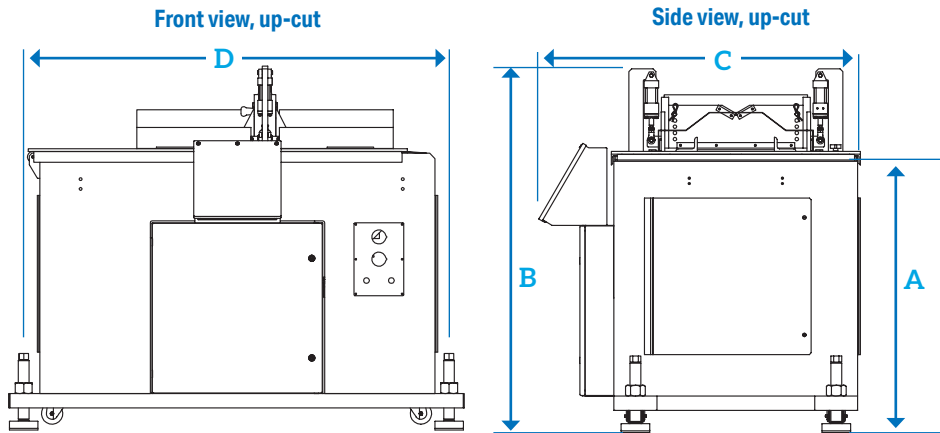

Models	TS524UP	TS724UP	TS920UP
Dimensions inches (mm)			
A	39.5 {1003.3}	37 {939.8}	37.5 {952.5}
B	57.125 {1450.98}	48.5 {1231.9}	50 {1270}
C	45 {1143}	46.25 {1174.75}	56.25 {1428.75}
D	64 {1625.6}	64 {1625.6}	67.5 {1714.5}

Models	TS524UP	TS724UP	TS920UP
Performance characteristics			
Applications	Pipe or Profile		
Pipe diameter capacity inches (mm)	5 {127}	7 {178}	9 {228}
Profile capacity inches (mm) H x W*	1 x 14 {25.4 x 355}	2 x 16 {50.8 x 406}	2.75 x 23 {69 x 584}
Blade diameter inches (mm)	18 {457}	22 {559}	27 {686}
Blade type	Carbide tipped		
Blade drive motor Hp (kW)	3 {2.4}	3 {2.4}	5 {3.73}
Blade speed	Variable blade speed standard on all models [†]		
Dimensions inches (mm)			
Height to centerline	42 {1067} (± 2)		
Maximum table travel	24 {609}	24 {609}	20 {508}
Voltage Full load amps[‡]			
460V/3 phase/60 Hz	Consult Conair		

Specification Notes

* Profile capacity H x W dimensions are provided for guidance only. The actual capacity can vary depending on the profile you are attempting to produce.

[†] Maximum blade surface speeds are individually configured based on each models blade diameter.

[‡] FLA data for reference purposes only. Does not include any options or accessories on equipment. For full FLA detail for power circuit design of specific machines and systems, refer to the electrical diagrams the equipment order and the nameplate applied to the machine.

Specifications may change without notice. Consult with a Conair representative for the most current information.

Control

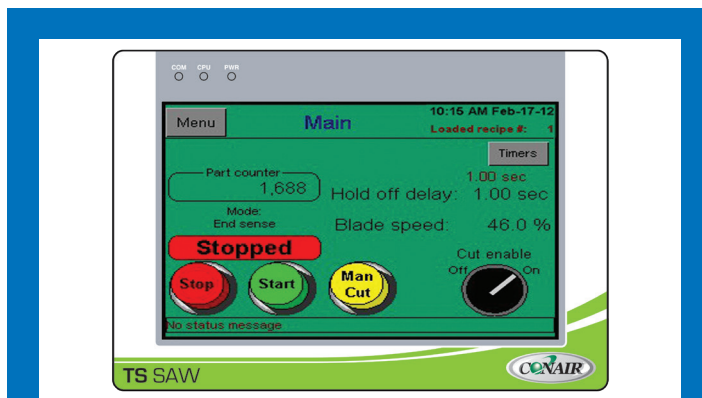

The TS Up-Cut features a full-color touchscreen control. Switch cutting modes, adjust blade speed, customize operation, save recipes, and create unique user privileges all from a touchscreen control that allows for easy communication to other devices. All Conair controls are designed with the same style icon/button operation, making learning a new piece of equipment easy and comfortable.

Options

- Special power: 230/3/60, 380/3/50 or 575/3/60
- Electronic cut to length measuring system with digital automatic reset counter and encoder for mounting to puller
- Servo drive package for saw table travel. System uses an AC servo motor with a precision planetary gear drive assembly
- Left-to-right extrusion direction
- Custom paint
- Special non-auto powder coat
- Chip collection system
- UL certification