

Accurate Small Batch Gravimetric Blending For Medical Use

Get accurate blends, better mixing, faster material changes and increased profits with Conair's MedLine® TrueBlend™ Series Blenders. Steep-sided material compartments allow resin to flow evenly and freely through vertical dispense valves into the weigh chamber. Efficient mixing assures full integration of all recipe ingredients. Fully-enclosed cabinet design assures no pellet spillage and clean operation. Standard convenient features such as quick access material compartment bins, a hinged chassis access door and removable components in the mixing chamber reduce downtime during cleanout.



Model TB45-4

Throughput Rates to 175 Pounds an Hour

The MedLine® TrueBlend™ TB45 Series Blenders offer small extruders and small tonnage injection molding machines a superior way to blend color and additives centrally or at the throat of the processing machine.

The blender dispenses up to four materials from respective material compartments into a common weigh chamber. The control determines the correct weight of each ingredient based on setpoints entered on the touch screen display. Up to 3000 recipes and 4000 resin names can be entered and stored in the processor.

Unique fast-acting "no stick" vertical valves control the amount of material dispensed. All dispense valves use two-way air cylinders assuring positive operation.

Choose between throat mounted or central blender models. Options include an integrated loader control feature, and a flow control valve for central blending applications.

Conair's MedLine blenders are designed to work in cleanroom environments with Conair's other MedLine solutions in extrusion, conveying, heat transfer, and drying.



▶ Calibrated to ISO standards

The MedLine TB45 is calibrated to ISO standards, perfect for any cleanroom application. The touch screen is chemical resistant, and easily cleaned by isopropyl alcohol. The RAL 9003 paint maintains the clean bright look you would expect in a cleanroom. Contact points are stainless steel.

▶ Blend accuracy to 1/2 of 1%

Colorant and/or additive weights are held to within 0.5% of setting. A selectable Precision Additive™ feature is also available for additives for even greater accuracy. The microprocessor control automatically calibrates after every cycle and compensates for variations in dispense method, resin bulk density or particle geometry.

▶ Easy-to-use control

Intuitive 7-inch LCD touchscreen control with full color graphics allows quick and easy setup of blender setpoints. All setpoints are displayed simultaneously. Enter the percentages of the blend on the touchscreen display and the blender does the rest. The system automatically weighs the recipe ingredients in the proper sequence and maintains the correct blend relationship. Any position can be identified as one of the four material type selections adding flexibility to your application setup.



▶ Convenient, easy clean out

Easy access to all material contact points for fast and safe cleaning during color or resin changes. Quick access material compartment bins, a removable weigh bin, mix agitator and mix chamber liner allow quick efficient cleaning. The blender features a built-in manual material shut-off valve below the mixing chamber, this can be replaced with the automatic flow control valve for remote and central blending applications.



Features

Intuitive, SB-5 touchscreen control offers the industry's best multi-component accuracy

This easy-to-use touchscreen control allows for fast setup of blender setpoints and automatically weighs recipe ingredients in the proper sequence to maintain correct blend relationship. Any position can be identified as any of the four material type selections, adding flexibility to your application setup.

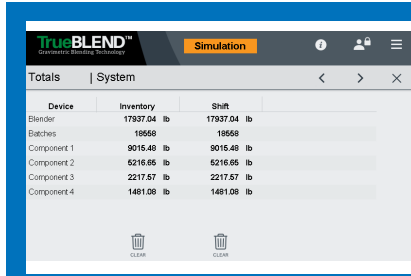

Instantly see your materials usage
Material usage / totals screen tracks the number of batches, weights dispensed by bin and weight dispensed in total since the last reset.

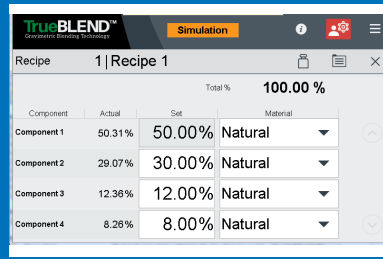

View and make changes to the active recipe
Save and recall up to 3000 recipes and 4000 resin names in the Recipe Book.

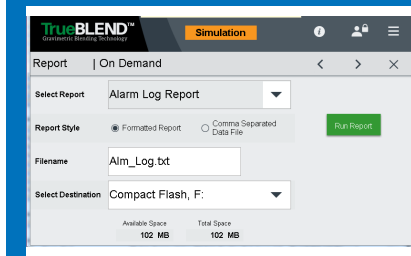

Built-in reporting
Every SB-5 Blender control is equipped with the capability to help users track their settings, alarms, material consumption, shift and inventory needs.

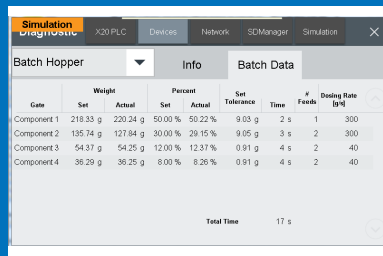

On-call diagnostics
Diagnostic screen displays target set point percentage and actual percentage dispensed. Also displays start and finish weights for each material per batch. Verifies true and accurate blend performance.

SmartBlend™ SB-5

Premium touchscreen control offers these high performance functions to target the unique process needs of molders and extruders.

- Best choice for the needs of rapidly changing custom jobs or sophisticated extrusion and molding applications with complex and highly critical recipes.
- Progressively approaches each ingredient target. Never overshoots. If setpoint is not met, remainder is recalculated to correct.
- Precision metering yields industry's best batch-to-batch accuracy.
- Precision ratio control - all components.
- Individual material accuracy settings.
- SMTP email alarm notification capable.
- VNC viewer for displaying and using the control screen on a larger monitor.
- SmartServices® ready.

Which package is right for you?

Standard Packages - 4 Component	TS	LS†
Features		
Material bin sight glasses	•	•
Touchscreen control	•	•
Loading control option		•
Machine mount with manual slide gate discharge †	•	•
Remote/bin mount with pneumatic slide gate discharge †	•	•
Calibration to ISO standards	•	•
RAL 9003 paint	•	•
Chemical resistant touch screen	•	•
Stainless steel material contact points	•	•
Feature Notes		
* Includes an optional integrated loader control feature.		
† Choose between either machine or remote mounted blender packages.		
Specifications may change without notice. Consult with a Conair representative for the most current information.		



Features

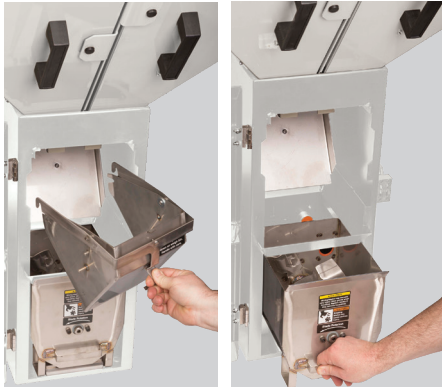

Simple and quick cleanout

Easy access to all material contact points for fast and safe cleaning during color or resin changes. Material compartment access doors, removable weigh bin, mix agitator and mix chamber allow quick efficient cleaning.



Optional floor stand with reservoir

Blender installs easily to this floor stand, which is equipped with a material reservoir. Each blender stand features:

- Sturdy design
- Easy cleanout
- Fork-lift provisions
- Drawer magnet provision
- One standard material takeaway tube (up to two additional material tubes are available as options)
- Available with one or two cubic foot reservoir capacities
- Optional casters (one cubic foot capacity model only - TBBS01)

Options



Air blow-off for mix chamber level sensor

This feature is integrated into the blender mix chamber to blow excessive dust and fines away from the mixing chamber sensor and ensure accurate level sensor reading.



Remote HMI operator cable

Place the SB-5 control up to six meters away with convenient plug-in cable set.



Remote mixer demand sensor

This sensor provides a fill-to-level option in a surge bin or other material receptacle that sits below a remote mounted blender.



Material level alarm control

Eliminate costly material shortage problems and machine downtime with this early warning system. The control monitors up to six material levels. Each sensor can be set as a high or low warning. See Level Alarm Control specification sheet.



Drain chute

For fast, safe, thorough and simple blender draining prior to cleanout. The drain chute quickly installs over the blender front opening.

Specifications

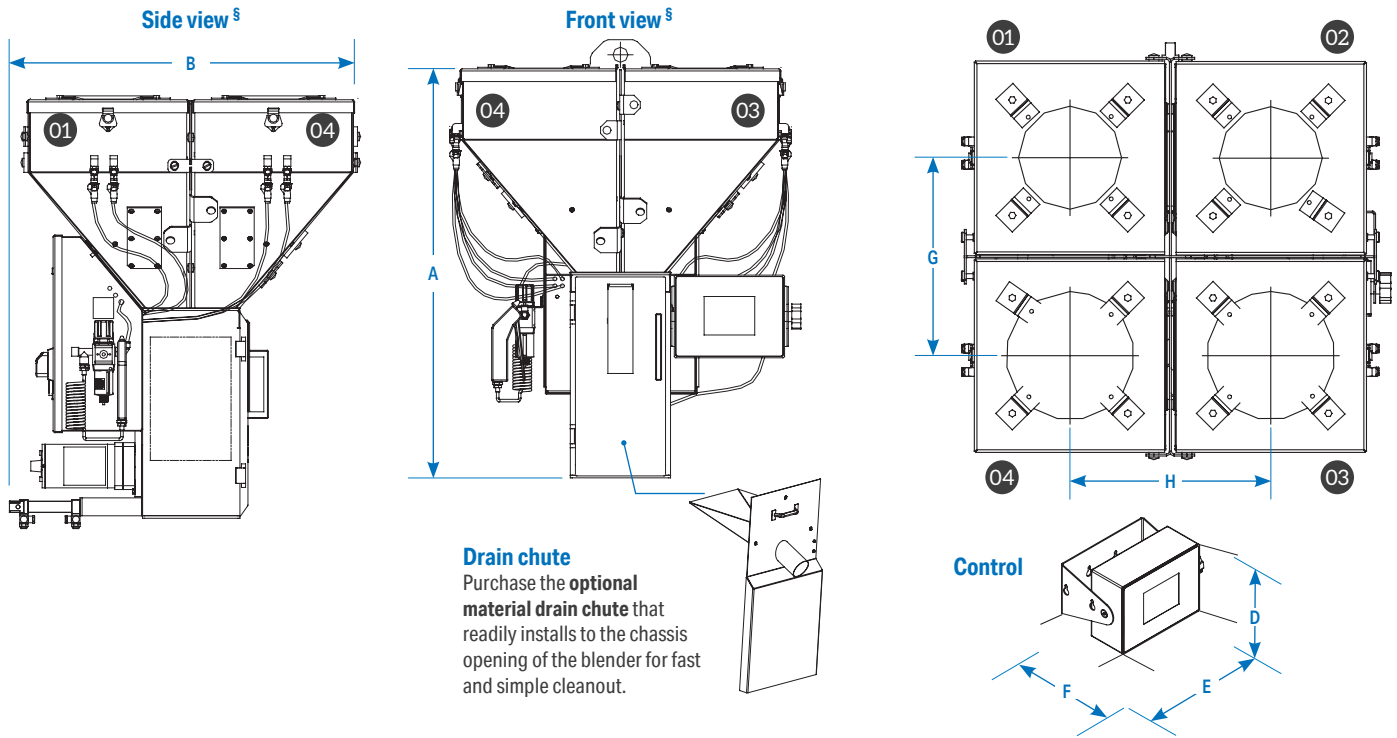

Drain chute
Purchase the **optional material drain chute** that readily installs to the chassis opening of the blender for fast and simple cleanout.

Models	TB45-4
Performance characteristics	
Batch size lbs {g}	1.0 {450}
Maximum throughput lbs/hr {kg/hr}*	175 {79}
Bin capacity - main ingredient ft ³ {liter}	0.2 {5.7}
Bin capacity - minor ingredient ft ³ {liter}	0.2 {5.7}
Maximum number of materials	4
Number of vertical discharge valves	4
Number (size) of major bin valves	2 - (40 mm)
Number (size) of minor bin valves	2 - (20 mm)
Dimensions inches (mm)	
A - Height above mounting plate†	32.50 {826}
B - Width	25.00 square {635}
C - Depth	27.00 square {686}
D - Control height	6.50 {165}
E - Control width	8.75 {222}
F - Control depth	6.75 {172}
G - Loader center distance	12.75 {324}
H - Loader center distance	12.91 {328}
Approximate weight lbs {kg}	
Installed	150 {68}
Shipping	230 {104}
Voltage Full load amps**	
115V/1 phase/60 hz	1.0
230V/1 phase/50 hz	0.5
Compressed air requirements	
Discharge valves	90 psi @ 0.2 ft ³ /min {6 bars @ 0.09 liters/sec}; 1/4 inch NPT fitting
Maximum loader sizes	
8-inch loaders	Number of loaders - 4

Application Notes Dimensions shown in inches and (mm).

Mixing chamber access door - this side of the interface

1-22/32 {45} diameter centered

Mounting bolt hole size (4 holes) 7/16 inch {11.0 mm}. Predrilled 5 x 5 mounting pattern as standard.

Specification Notes

- * Maximum throughput rates are based on 35 lb/ft³ pelletized material, using all standard valve sizes. Use of reducer inserts will lower the rate shown. Throughput rates are based on:
 - A 4-position blender recipe of 20% regrind, 80% natural, 3% color and 2% additive material.
- † The optional flow control valve will mount inside the chassis in the space of the manual slide valve. The optional automatic flow control valve is recommended when mounting the blender on a stand, surge bin or hopper.
- ‡ Hopper positions three and four are supplied with eight inch cover plates as standard.
- § Numbers in top view drawings represent hopper positions.
- ** FLA data for reference purposes only. Does not include any options or accessories on equipment. For full FLA detail for power circuit design of specific machines and systems, refer to the electrical diagrams of the equipment order and the nameplate applied to the machine.

Specifications may change without notice. Consult with a Conair representative for the most current information.

