

Easier Access, for Simplified Medical Use

Cleaning and maintaining your medical loaders is now faster, easier and safer than ever before. That's because the unique angled canister design of the Conair MedLine® Access™ Loader (AL) means workers don't need to climb as high or work as hard to service the drop-in filter or wipe out the stainless steel canister.

A hinged lid opens easily, without tools, tilts back and locks out of the way safely leaving both hands free for cleaning or service.

The RAL 9003 MedLine white paint, and the stainless steel construction make the AL a perfect self-contained loader for medical applications outside the cleanroom.



Access Model AL-2
with ELC Control

Value-added Features at No Additional Cost

The Access™ Loader (AL) Series delivers all the performance and reliability you expect from Conair, plus added features and benefits at no extra cost. The RAL 9003 (white) hinged lid tilts back and locks out of the way. Pulsed filter cleaning is included as standard and greatly extends operating time before filter cleaning is required.

The powerful vacuum motor is protected by a sound-dampening plastic housing that is both attractive and durable. For more challenging loading applications, the AL can be supplied with a long-life, extra powerful brushless motor.

Access Loaders are equipped with Conair Easy Loading Controls (ELC) featuring a graphical illustration of loader functions with LED lights. Expanded loading functions are available with use of an optional ControlMate™ pendant.

▶ **The world's most reliable discharge valve**

Surrounded by protective feet, the large, cast aluminum outlet closes off with a stainless steel, weight-biased flapper against a rugged, high temperature seal. The non-contact demand level sensor is fool-proof.

▶ **Select option packages to suit your needs**

Popular options are combined for easy selection and integrated into your loader purchase.

▶ **Full-featured Control**

The Easy Loading Control (ELC) and optional ControlMate™ pendant provide simple, reliable loading operation and can also control line purging, ratio loading and many other loading parameters.



▶ **Optional customizable ratio valve**

The ratio valve's top and bottom material inlets can be conveniently positioned facing forward or backwards for convenient connection to your material lines.

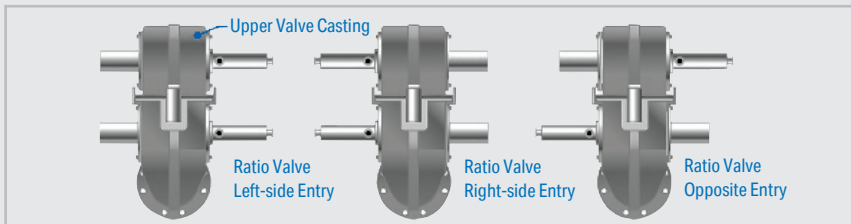

How it Works

Loading control

Each on-demand loading sequence is clearly exhibited on the graphical control face with bright, simple LED lights. A "no-load" alarm light and buzzer are included.

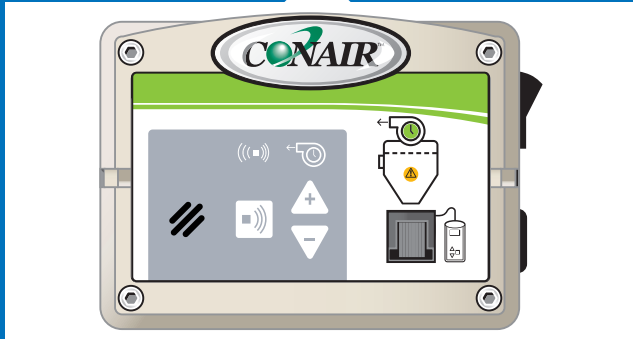

The discharge flapper, when held open by material, prevents loading (Figure 1). When the material level drops and the flapper swings shut (Figure 2) the loader's demand switch tells the loader control to turn on the vacuum motor and start loading resin. The material is drawn into the loader body until the loading timer stops the motor. Loading stops and resin is dumped from the loader while the blowback bursts clean the filter.

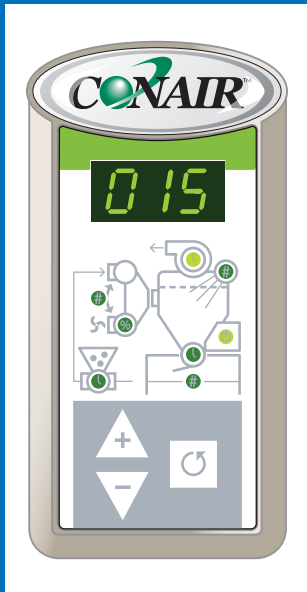

Figure 1



Figure 2

ControlMate™ Pendant (optional)



ControlMate™ Pendant

The ControlMate pendant expands your loader's capabilities while providing convenient remote controls for your Access Loader. The ControlMate includes a 15 foot connection cable and handy holster.

A helpful graphic and array of LEDs, illustrate expanded loading functions like ratio loading and line purging while a three-digit numeric display shows each functions setting as it is selected.

• Interchangeable programming

One pendant can be moved from one ELC control to another to program advanced settings. The same ControlMate pendant can even be used with Conair's ELC-16 central vacuum controls.

Note: ControlMate pendants hold no program data, so one pendant can be freely used with the entire family of Conair ELC controls. Data, once programmed with the ControlMate, safely resides in each ELC control.

• Change up to 16 parameters

The additional loading functions available with the ControlMate Pendant include:

- | | | |
|--------------------|-----------------------|--|
| • On/Off | • Load time | • Fill sensor present |
| • Unload time | • Blowback | • Load and hold |
| • Load attempts | • Priority demand | • Purge / Adjustable Purge Valve (APV) |
| • Ratio layers | • Fill sensor logic | • Ratio installed |
| • Ratio percentage | • Demand sensor logic | • Blowback installed |
| • Purge time | | |

Note: Some ControlMate functions require additional components for their operation, i.e.: Ratio Valve, Purge Valve.

ControlMate™ Function

01

Push the Function button  until the appropriate LED indicator is illuminated to change any loading parameter.

02

Use the (+) or (-) buttons located to the left of the Function button to change a loading parameter to your requirements.

03

Once your parameters are changed there is no need for further keys strokes, all parameters are instantly saved to the ELC control.

Features



01
Stainless steel cylindrical, angled body provides easy access to internal drop-in disc filter.

02
All material contact surfaces are built of pristine stainless steel or aluminum to prevent corrosion.

03
ELC-M loading control with intuitive loader display. Enhanced control capabilities are possible with the optional ControlMate pendant.

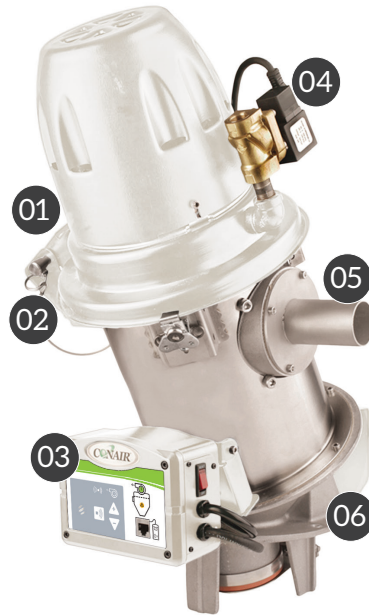

04
Blowback solenoid for the removal of dust or particulates that accumulate on the loader's internal disc filter.

05
Bolt-on replaceable inlet stub (1.75 inches {44.45 mm} standard). May be re-oriented for optimum material line routing.

06

- Anodized base
- Protective stand-offs
- Integral discharge flapper

Options



Stainless steel JIT Hopper
Fill machine throats directly with "Just-In-Time" stainless steel hoppers. Three sizes are available:

- 10 lb capacity for AL-2 loaders
- 20 lb capacity for AL-5 loaders
- 40 lb capacity for AL-5 loaders

Hinged lids with hold-up arms allow easy access for cleaning and inspection without removing the loader. A drop-in grate magnet may be included. A remote demand sensor bracket and clean out chute are provided on JIT-20 and JIT-40 models.



Glass Hopper
AL-2 model Access Loaders can be mounted directly to a machine throat with a pristine direct feed glass hopper. Three capacities are available to accommodate throughput and/or shot size needs. Quick disconnect clamps allow easy loader removal. An optional drop-in grate magnet maybe provided. A height-adjustable demand sensor bracket is included, allowing fill level adjustments.

Remote demand sensor
Move the fill level of the vessel being loaded to an alternate level to meet process needs. The remote demand sensor is useful on JIT hoppers (as shown above, left), glass hoppers, drying hoppers and bins. May also be used on granulators, to start off-loading when regrind is present. Extension cables are available.

Ratio valve
This dual inlet material valve mounts to the Access Loader for loading regrind alternatively with virgin material. Ratio Valve is nickel-plated (high wear). Requires ControlMate pendant for V/R time settings. Ratio Valve field retrofit kits are available.



High-wear kit
T-1 tool steel deflector plate is added to the inside of the loader's body to reduce wear from highly abrasive materials, such as glass-filled compounds.

Volume fill sensor
Provides efficient, automatic shut-off of the vacuum motor when the loader is full. An alarm light signals if the fill sensor has not been reached during loading.

Adjustable inlet positions
The loader body may be rotated to position the material inlet to the best location for your conveying line.

Specifications

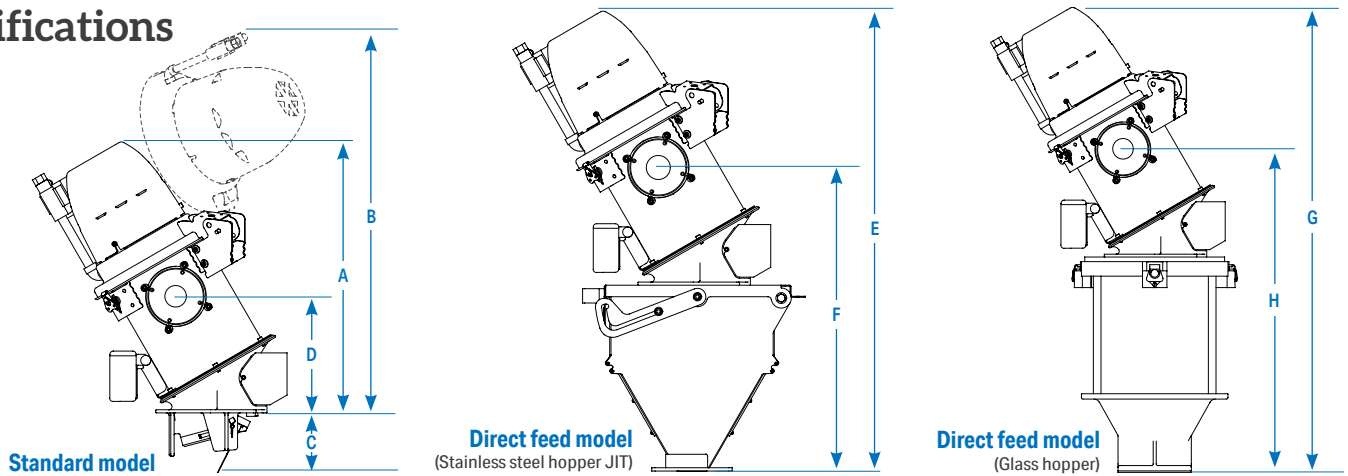

Model	AL-2	AL-5	AL-5*
Performance characteristics			
Loader volume ft ³ {liters}	0.2 {6.0}	0.5 {14}	
Loader body diameter inches {mm}	8.0 {203.0}	12.0 {304.0}	
Material inlet diameter inches {mm}	1.75 {44.5} (std.), 1.5 {38.1} (opt.)	1.75 {44.5} (standard), 2.0 {50.8} (opt.)	
Loader maximum temperature rating °F {°C}	180 {82}	180 {82}	150 {66}
Vacuum motor	5/8 Hp - 2 Brush	7/8 Hp - 4 Brush	1.3 Hp - Brushless
Nominal throughput [†] lbs/hr {kg/hr}	200.0 {90.0}	500.0 {227.0}	1000.0 {454.0}
Maximum conveying distance ft {m}	50.0 {15.2}	75.0 {22.9}	120.0 {36.6}
Discharge type	Gravity flapper		
Demand sensor	Integrated reed switch / Remote capacitance sensor (optional)		
Compressed air requirements	80 psi {5.52 bar}, 2 ft ³ /min {0.057 m ³ /min}, NPT fitting: 3/8 inch		
Dimensions inches {mm}			
A - Height above mounting plate	20.4 {518.2}	23.2 {588.52}	
B - Height above mounting plate with open lid	29.7 {754.4}	34.0 {863.6}	
C - Depth below mounting plate	4.9 {124.5}	8.1 {206.3}	
D - Height to center of material inlet	8.8 {223.5}	8.6 {219.5}	
Mounting details			
	See Figure 1		See Figure 2
Approximate weight lb {kg}			
Installed	28 {13}	49 {22}	
Shipping	50 {23}	65 {30}	
Voltage[‡] Full load amps @ VAC			
	8 @ 110, 4 @ 220	14 @ 110, 7 @ 220	17 @ 110

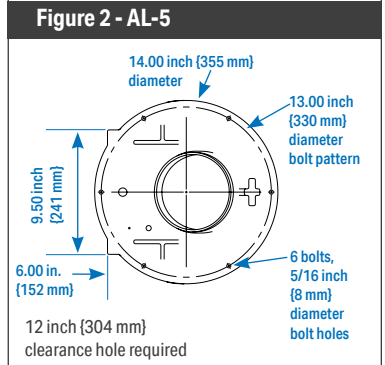
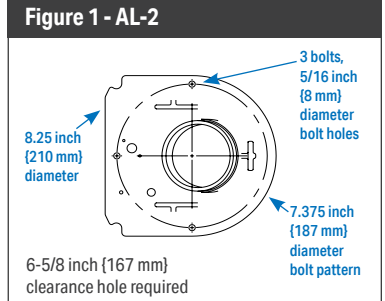

Stainless Steel JIT Hopper

Model	AL-2	AL-5	
JIT Hopper model	JIT-10	JIT-20	JIT-40
JIT Hopper capacity lb {kg}	11.1 {5.1}	24.3 {11.0}	41.5 {18.8}
Dimensions with Access Loader inches {mm}			
E - Height above mounting plate	34.3 {871.2}	42.1 {1069.3}	45.2 {148.1}
F - Height to center of material inlet	22.6 {574.0}	27.7 {703.6}	30.8 {782.3}
Mounting details			
	See Figure 3		
Approximate weight lb {kg}			
Installed	45 {20}	80 {36}	85 {39}
Shipping	67 {30}	96 {44}	101 {46}

Glass Hopper

Model	AL-2		
Glass Hopper model	3 lb	11 lb	21 lb
Glass Hopper capacity lb {kg}	3.0 {1.4}	11.0 {4.9}	21.0 {9.5}
Dimensions with Access Loader inches {mm}			
G - Height above mounting plate	32.4 {822.5}	38.1 {966.7}	49.6 {1260.6}
H - Height to center of material inlet	20.8 {527.1}	26.5 {672.6}	38.0 {965.2}
Mounting details			
	See Figure 4		
Approximate weight lb {kg}			
Installed	43 {19}	49 {22}	59 {27}
Shipping	65 {30}	71 {32}	82 {37}

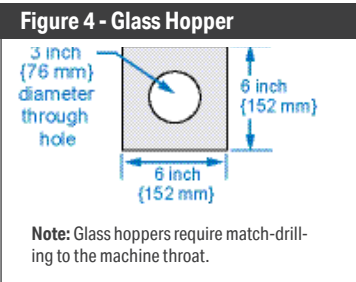
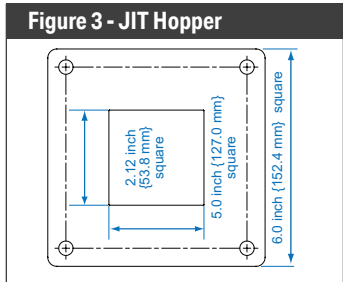

Specification Notes

- * Available with brushless motor as standard. 1.5 inch (38.1 mm) material inlet not available with brushless motor.
- † Throughputs beyond the recommended ratings should not be attempted unless you are conveying virgin material from close distances. Higher throughputs could result in shortened brush and/or filter life. For higher throughputs, consult Conair for a quote on central vacuum loaders.
- ‡ Brushless motors are only available in 110 VAC.

All Access Loaders are shipped with 15 ft (4.572 m) of flex hose and a vertical feed tube. Specifications may change without notice. Consult with a Conair representative for the most current information.

