

Automatic Machine-side Drying

Conair Carousel Plus™ dehumidifying dryers guarantee moisture removal from resins, regardless of moisture content. You can be assured your molded or extruded products will be unaffected by moisture content that can jeopardize their quality.

These D Series dryers feature automatic Temperature Setback (to protect resin and save energy), and automatic Dewpoint Control (for changing moisture content). Equipped with highly efficient desiccant wheels, long-life tube heaters and powerful blowers, Conair D Series Dryers can be coupled with 1 or more hoppers for efficient resin drying up to 400 lbs/hr {181.4 kg/hr} (see chart, next page).

D150 through D400 dryers offer two levels of touchscreen controls, for the simplest, yet most sophisticated control over the drying of your valuable resin.



Model D150
Shown with
DC-C control

Throughputs from 150 to 400 lb/hr; Simple UX for new operators

Conair Carousel Plus Dryers use molecular sieve desiccant that is bonded onto a fiberglass substrate and formed into a light, compact, continuously rotating wheel that never breaks down, while providing low-pressure, free-flow of dehumidified air.

The result is rock-steady, spike-free drying temperatures and low, consistent dewpoint levels, critical for processing moisture and temperature sensitive resins. Desiccant is efficiently regenerated at reduced temperatures, making Conair Carousel Plus Dryers the most energy efficient dryer you can buy. Maximum uptime with minimal energy usage.

The optional air-to-air aftercooler eliminates the need for cooling water, saving additional installation and operation costs.

Also available as a mobile drying and conveying unit. Refer to the dX spec sheets for more info.

▶ Pleasant user experience (UX) with a simple-to-use touchscreen control

The DC-B control platform maximizes user confidence. Designed with new operators in mind, the 4-inch "Plus", or 7-inch "Premium" touchscreen control has new intuitive navigation, with tutorial help screens. Training new operators is easy and quick, making even the most novice operators feel comfortable. The color touch screens feature detailed trending, auto start, password protection and recipe control.

▶ Closed-loop drying and optional included conveying system

Each dryer uses a 2-blower closed-loop drying system which makes them ultra consistent and efficient, no matter what the location or time of year.

▶ Maximum uptime, maximum reliability, smaller footprint

With significantly reduced part count, easy access and less wear, you can expect many years of trouble-free operation. There are no indexing desiccant beds, no complex air valves, and no loose desiccant beads. The desiccant wheel is solid, and continuously rotating. Start and stop timers allow you to pre-dry resin, so it's ready when needed.

▶ Precise, adjustable dewpoint control

Included on all Carousel Plus Dryers, Dewpoint Control allows the system to adjust - in real time - to changing incoming moisture of the material while holding a user selected dew point value. This insures a rock solid dew point at the lowest energy usage.

DC-B Control Features and Options

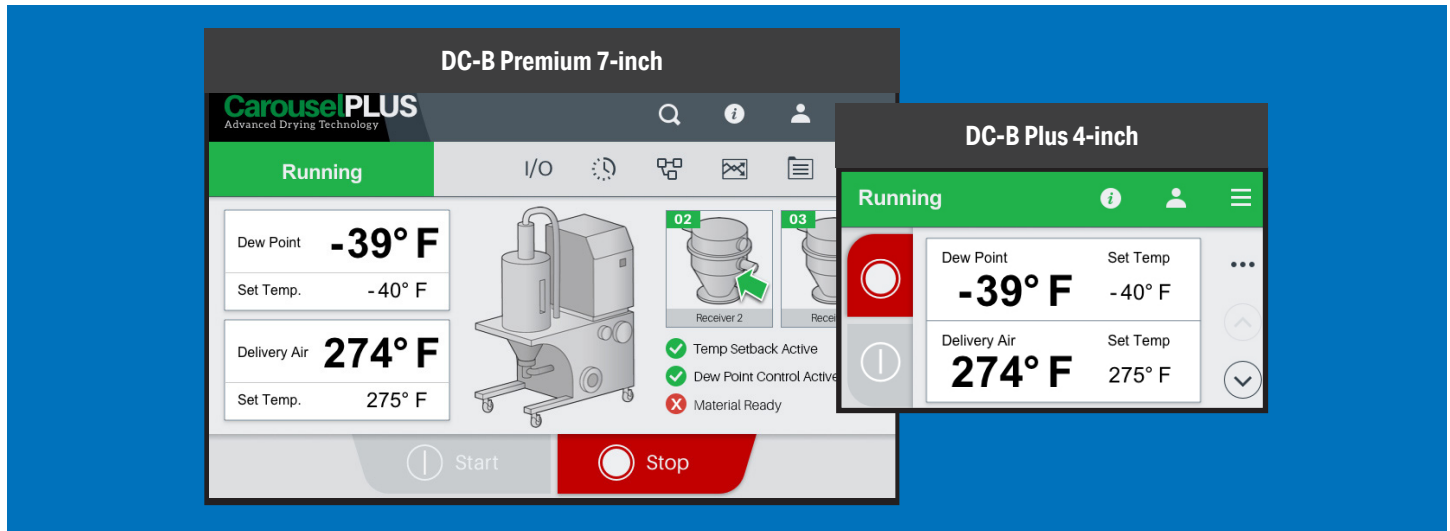

Control	DC-B Plus	DC-B Premium
Standard		
Processor	PLC	PLC
Display / HMI screen	4-inch color	7-inch color
Real-time data trending	●	●
Auto start/stop (7 days)	●	●
English / Metric units	●	●
Multi-level password protection	●	●
Temperature Setback (manual/auto)	○	●
Dewpoint monitor and control	●	●
Energy Usage Monitor	●	●
Audible and Visual alarms	●	●
Predictive maintenance	●	●
Recipe library control	●	●
On-screen help	●	●
VNC viewer	●	●
Wheel rotation sensor	●	●
Available options		
Drying Monitor w/ Material Ready		○
Vacuum conveying control	○	○
Number of vacuum receivers	1	2
Optional inputs (fill)	0	2
Optional outputs (ratio/purge)	0	1
Airflow measurement		○
Process filter check		○
Water flow control		○
Water flow on/off	○	
UL 508A panel design	○	○
Volatile trap (water-cooled only)	○	○
Precooler (to run below 150°F)	○	○
Communications (OPC-UA or Modbus TCP/IP)	○	○
Air-cooled aftercooler	○	○

● Standard ○ Option

Feature Descriptions (see chart for standard vs options)

- **Audible and visual alarm** - A flashing alarm beacon and horn.
- **Temperature setback** - Automatically reduces the drying temperature to a lower standby mode when the machine throughput is reduced or stopped.
- **Dewpoint monitor** - Monitor dryer performance with a digital readout.
- **Dewpoint control** - Allows the dryer to maintain an operator-selected dewpoint and adjust automatically to changing moisture content.
- **Drying Monitor™** - Save time and money by not using improperly dried material. Drying Monitor automatically monitors the heat profile in the hopper, using a 6-zone temperature probe, preventing over or under drying material. An alarm will alert operators of issues.
- **Material ready** - "Material ready" is a feature that alerts the operator once the material is properly dried. No more bad parts from improper drying when the resin wasn't ready!
- **On-screen help** - A simple click of the contextual help button gives information to the operator about functions and setpoints for each screen/button. The perfect tutorial for new operators.
- **Preventive maintenance** - Recommended maintenance intervals are programmed into the control, so you'll never wonder if it's time to perform maintenance, or forget about key tasks. This is just another way to prevent unplanned downtime.
- **Communications** - Allows the dryer to talk with Conair's SmartServices cloud or your own network via Modbus TCP/IP or OPC-UA communication protocols. Capabilities include viewing data in real time, pushing commands to the dryer, or controlling the system remotely using the built-in VNC virtual connection.
- **Air-to-air aftercooler** - no cooling water hook-up is required for operation. An aftercooler is used to reduce the temperature of the return air from the hopper, which improves the efficiency of the desiccant. Conair dryers can dry between 150-375°F {65.6-190.5°C} as standard with the water or air-cooled after cooling.
- **Process filter check** - A clogged filter will not only decrease dryer performance, it can cause bad end parts, damage the desiccant wheel, pose a safety hazard, or result in unscheduled downtime and increased repair costs. A differential pressure sensor across the filter lets you know when it's ready for a change.



Specifications

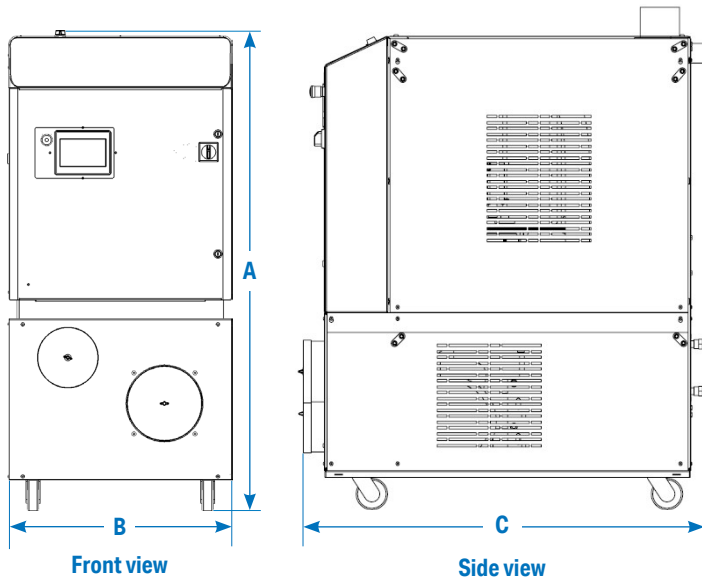

Application Notes

All dryers are supplied with an aftercooler as standard. The aftercooler reduces the temperature of the return air from the drying hopper, improving the efficiency of the desiccant. If using the water-cooled aftercooler, the aftercooler must be connected to supply water with the proper flow rate and temperature.

Central drying

Central dryers have no process heaters and are used to supply dry air to multiple drying hoppers. The central dryer, equipped with a desiccant wheel and regeneration system, supplies dehumidified air, which is heated to individual set points by the heaters and controls located at each drying hopper. These D Series dryers are not able to be used as central drying systems.

Additional filtration options

The standard return air cartridge filter is sized for the airflow of each dryer model and is suited for most applications. You should consider adding an optional dust collector and/or volatile trap if:

- The material contains excessive fines. An additional dust collector or cyclone will extend time between filter cleaning.
- The material produces volatiles during drying which condense into a waxy or oily residue. A volatile trap will help to protect the desiccant.

Models	D150	D200	D300	D400
Performance characteristics (with full hopper)				
Drying temperature *	100° - 375°F (38° - 191°C) with options			
Dewpoint	-40°F (-40°C)			
Dimensions inches (cm)				
A - Height	64.1 {162.8}			
B - Overall width	27.2 {69.1}			
C - Depth	49.3 {125.2}			
Outlet/inlet tube size OD	2.5 {63.5} or 5.0 {127}		5.0 {127}	
Approximate weight lbs (kg)				
Installed	610 {276.7}	620 {281.2}	660 {299.4}	740 {335.7}
Shipping	710 {322.1}	720 {326.6}	760 {344.7}	840 {381}
Voltage - Full load amps (standard dryer / central drying)				
230 V/3 phase/60 Hz	42.5 / 17.4	55.6 / 17.9	65.6 / 28	N/A
400 V/3 phase/50 Hz†	24.6 / 10.1	32.2 / 10.6	38 / 16.3	64.3 / 21
460 V/3 phase/60 Hz	21.4 / 8.6	27.7 / 8.9	32.8 / 14	55.7 / 18.1
575 V/3 phase/60 Hz	17.2 / 7.1	22.4 / 9	26.5 / 13.1	44.7 / 16.7
Water-cooled requirements (for aftercooler or precooler)‡ §				
Recommended temperature**	45° - 85°F (7.2° - 29.4°C)			
Water flow gal./min. {liters/min.}	3 {11.4}			
Water connections NPT	3/4 inch			

Specification Notes

- * Total kW listed at a process setpoint of 250°F (121°C) and a regeneration temperature of 350°F (177°C).
- † Dryers running at 50 Hz will have 17% less airflow, and a 17% reduction in material throughput.
- ‡ When drying below 150°F (66°C) a precooler is required.
- § When ambient temperature is above 110°F (43°C) and drying above 375°F (191°C) a water-cooled aftercooler is required.
- ** Temperatures above or below the recommended levels may affect dryer performance. Tower, chiller or municipal water sources can be used.
- †† FLA data for reference purposes only. Does not include any options or accessories on equipment. For full FLA detail for power circuit design of specific machines and systems, refer to the electrical diagrams of the equipment order and the nameplate applied to the machine. Specifications may change without notice. Consult a Conair representative for the most current information.

