



www.conairgroup.com

USER GUIDE  
UGB022-0519  
Software Version V1.07

# TrueFeed™ Touch

## Gravimetric Feeder



Please record your equipment's model and serial number(s) and the date you received it in the spaces provided.

It's a good idea to record the model and serial number(s) of your equipment and the date you received it in the User Guide. Our service department uses this information, along with the manual number, to provide help for the specific equipment you installed.

Please keep this User Guide and all manuals, engineering prints and parts lists together for documentation of your equipment.

Date:

Manual Number: UGB022-0519

Serial Number(s):

Model Number(s):

**DISCLAIMER:** Conair shall not be liable for errors contained in this User Guide or for incidental, consequential damages in connection with the furnishing, performance or use of this information. Conair makes no warranty of any kind with regard to this information, including, but not limited to the implied warranties of merchantability and fitness for a particular purpose.



# INDEX

## Table of Contents

<b>1. Introduction</b>	<b>3</b>
1.1 Symbols	3
1.2 Terms	3
<b>2. General information</b>	<b>4</b>
2.1 Safety	4
2.2 Certification	4
2.3 Operating environmental conditions	4
<b>3. Overview Dosing unit</b>	<b>5</b>
3.1 TrueFeed™ Component overview	5
3.2 Weighing frame	6
3.3 Motor and dosing system	6
<b>4. Metering principle</b>	<b>7</b>
<b>5. Dosing systems / Capacities</b>	<b>8</b>
<b>6. Installation</b>	<b>10</b>
6.1 Transport	10
6.2 Receipt	10
6.3 Mechanical Installation	10
6.4 Electrical installation	11
<b>7. Operation</b>	<b>12</b>
7.1 The Interface	12
7.2 Start-up & Login	12
7.3 Configuration	14
7.4 Production	20
7.5 Save data function	25
7.6 Filling the hopper	26
7.7 Alarms	32
7.8 Recipe function	34
7.9 USB menu	36
7.10 Screenlock	36
7.11 Consumption counters	37
7.12 Material Calibration	38
<b>8. Dual Station</b>	<b>40</b>
8.1 Electrical installation	40
<b>9. System performance</b>	<b>42</b>
<b>10. Trouble shooting</b>	<b>43</b>
<b>APPENDIX A: TrueFeed Wiring Diagram</b>	<b>44</b>
<b>APPENDIX B: TrueFeed Technical Specifications</b>	<b>45</b>
<b>APPENDIX C: TrueFeed Decl. of Conformity</b>	<b>46</b>

# 1. Introduction

Thank you for purchasing a Conair metering device. This manual is addressed to operators and **qualified technicians** taking care of the metering of dry additives to ensure correct use of the Conair dosing unit.

① **IMPORTANT NOTE: THIS MANUAL MUST BE READ BEFORE INSTALLING THE DOSING UNIT. KEEP THIS MANUAL IN A PLACE ACCESSIBLE FOR ALL OPERATORS.**

## 1.1 Symbols

① Important note



Attention; safety regulations for the operator

## 1.2 Terms

**Operator:** A person charged to operate, adjust, maintain and clean the machine.

**Qualified Technician:** A specialized, suitable trained person authorized to execute the installation, non-routine maintenance, or repairs requiring special knowledge of the machine and how it operates.

## 2. General information

### 2.1 Safety



The equipment is only designed and may only be used for the dosing of dry additives. Any use that is not in conformity with the instructions is considered improper and as such frees the manufacturer from any liability regarding damage to things and/or persons.



Before switching on the unit for the first time, ensure that the main power voltage applied is between 80 and 260Vac.



Always switch off the Conair control cabinet and disconnect the main power plug from electrical power before performing maintenance.



Ensure that all parts are securely fixed to the extruder or injection molding machine.



Dangerous voltages are present inside the control cabinet for up to 2 minutes after it has been switched off.

### 2.2 Certification

The Conair dosing unit is designed and produced in conformity with the following European regulations:

- CE standards for machinery (health, safety, environment)
- EMC (electromagnetic compatibility)
- VEM (safety electric material)
- 2006/42/EG (See the declaration of conformity, Appendix E)

### 2.3 Operating environmental conditions

- The unit must be protected against weather conditions
- Operating temperature -4 to +158°F {-20 to +70°C}
- Protection class: IP-50

# 3. Overview Dosing unit

## 3.1 TrueFeed™ Component overview

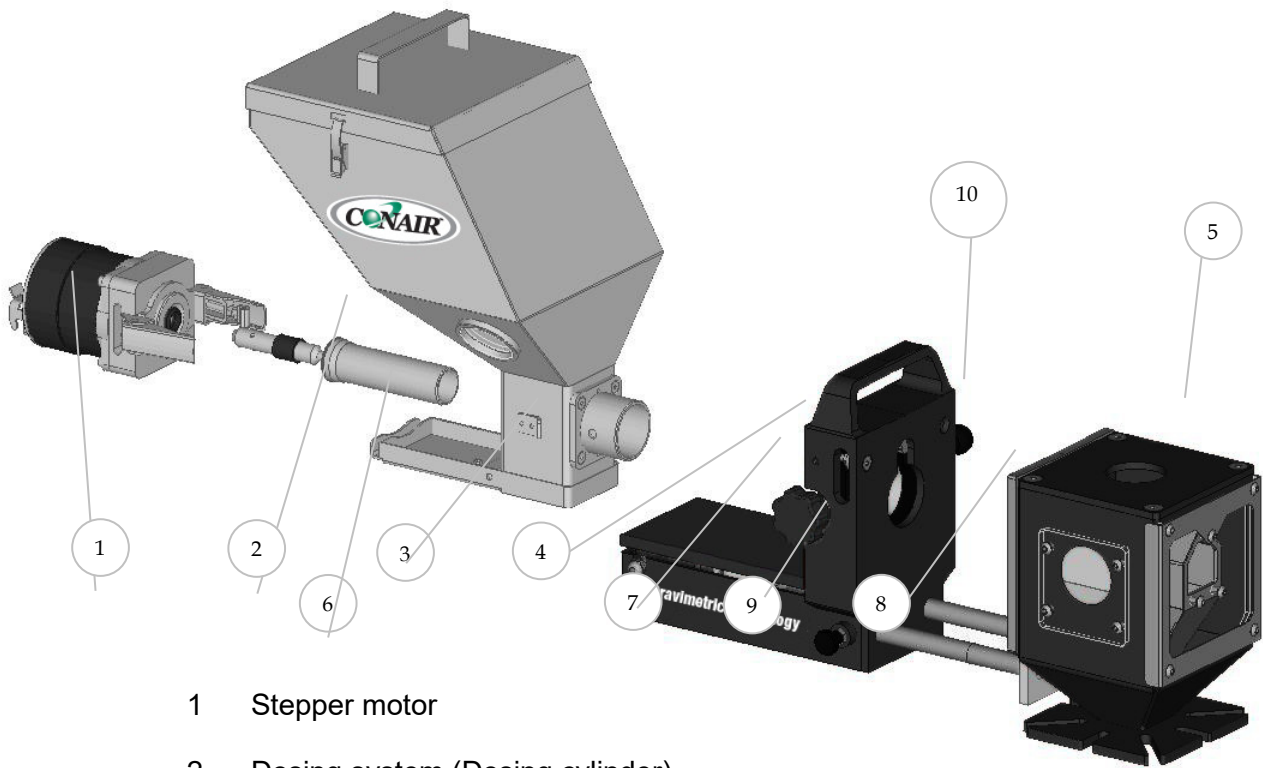

- 1 Stepper motor
- 2 Dosing system (Dosing cylinder)
- 3 Hopper 0.2 ft<sup>3</sup> {6 liter}
- 4 Curled knob M10x40
- 5 Standard NST40 Neckpiece
- 6 Material discharge slide (in closed position)
- 7 TrueFeed Load frame
- 8 *OPTIONAL Slide frame*
- 9 *Slide locking bolt  
(locking the slide-out position)  
Only supplied together with the optional slide mechanism*
- 10 *Slide locking bar (locking the slide-in position)  
Only supplied together with the optional slide mechanism*

### 3.2 Weighing frame

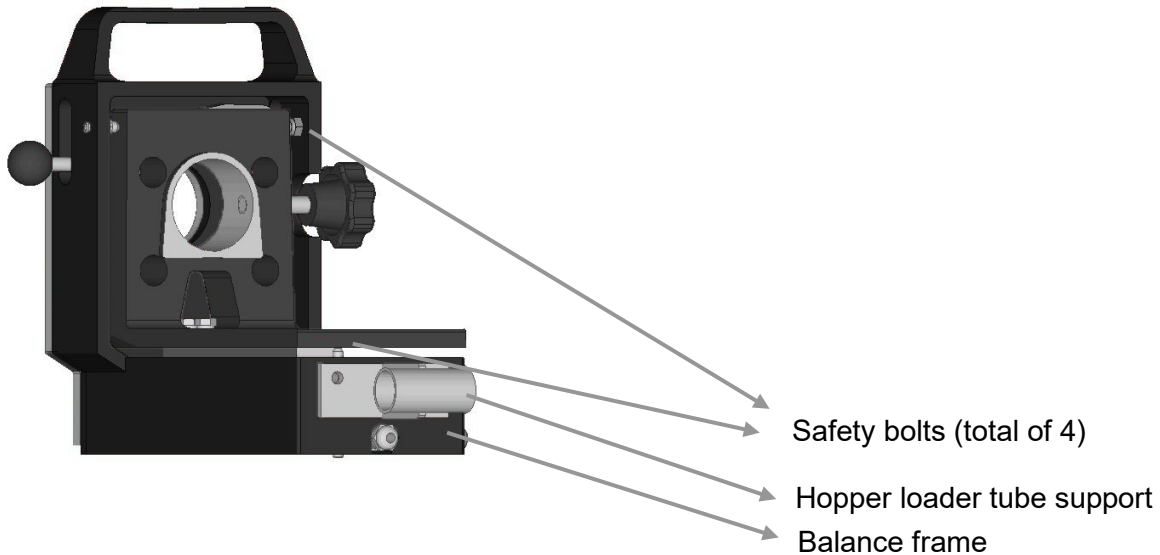

The black part is the weighing frame.

**Do not touch this weighing frame (and dosing unit) while dosing.**

It will have influence on the dosing.

Do not touch the safety bolts under the weighing platform. These are for overload protection.

There must be some space between the safety bolts and the frame.

### 3.3 Motor and dosing system

There are mainly two dosing systems, the dosing cylinder and the feed screw.  
(for more information see chapter 5)

The serial number of the motor can be found on the backside of the motor.



#### **Motor axle:**

The motor shaft is equipped with one flat side which fits exact in shaft of the dosing cylinder.

To connect the dosing cylinder just put it on the motor axle while turning it to find the flat side, then press the dosing cylinder completely backwards.

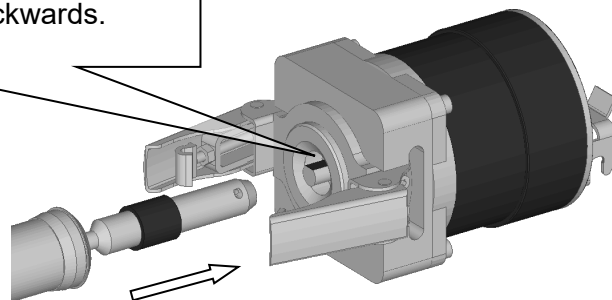

## 4. Metering principle

The Dosing Cylinder® of Conair combined with a very precise adjustable stepper motor ensures that the additive output is accurate and regular. The neckpiece (a mixing chamber) is designed to blend the main material and the additive homogeneously. Conair has on stock a large range of machine neckpieces that usually makes a perfect fit to the injection molding machine or extruder. The most common mounting of the neckpiece is between the production machine and the hopper. In the figure below a cut through of the NST40 neckpiece can be seen.

### Standard neckpiece

During operation, the virgin material runs from the machine hopper through the neckpiece into the machine. Inside the neckpiece the Virgin material flow is divided into two streams by the cover plate. In the space below the cover plate, the rotating cylinder is dosing additive.

Additive is added directly into the center of the virgin material flow, just before it enters the production machine. This is a great advantage over metering devices that use batch pre-mixing because pre-mixing can actually cause material separation. Separation of materials results in an irregular additive flow into the production machine.

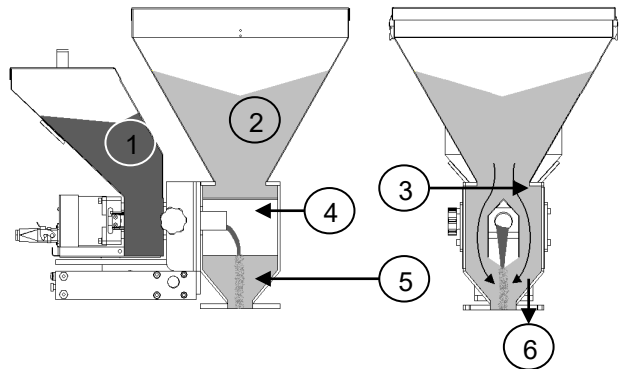

Fig. 3

1. Color
2. Virgin material
3. Neckpiece
4. Dosing cylinder
5. Cover plate
6. To production machine

# 5. Dosing systems / Capacities

Depending on the application a different dosing system might be needed. Use the following table to determine roughly the best system for the application. For more detailed information please contact your agent or Conair.

## Dispensing Cylinders



Feeding system	Pellet material	Regrind / hard-to-flow material	Feed rate† gram/sec	Feed rate† kg/hr	Feed rate† lb/hr
GLX	Yes	No	0.01 to 1.1	0.05 to 4.1	0.11 to 8.9
GX	Yes	No	0.1 to 5.0	0.5 to 12.6	1.11 to 28.0
HX‡	No	No	0.007 to 0.4	0.03 to 1.3	0.56 to 2.78
A-8LT	Yes	Yes	0.01 to 1.1	0.05 to 4.1	0.11 to 8.9
A-15LT	Yes	Yes	0.1 to 5.0	0.5 to 12.6	1.11 to 28.0
A-20LT	Yes	No	0.4 to 14.0	1.3 to 50.4	2.78 to 112.0
A-20HT*	Yes	Yes	0.4 to 14.0	1.3 to 50.4	2.78 to 112.0
A-30HR*	Yes	Yes	1.4 to 35.0	5.0 to 126.0	11.1 to 280.0

\* Used for regrind and irregular shaped materials.

† Feed rates are based on materials with a bulk density of 35 lb/ft<sup>3</sup>.

‡ For granular/free-flowing powder.

Note \* Used for regrind and irregular materials.

Note † Feed rates are based on materials with bulk density of 35 lb/ft<sup>3</sup>.

Note ‡ For granular / free-flowing powder.

### Which type of dosing system do I need with which neckpiece?

TYPE	CODE FOR STANDARD NECKPIECE	CODE FOR WATERCOOLED NECKPIECE
GLX	GLX	GLXC
GX	GX	GXC
HX	HX	HXC
A8LT	A8	A8C
A15	A15	A15C
A20LT	A20	A20C
A20HT	A20HT	A20HTC
A30HT	A30	A30C

All Conair dosing units are standard equipped with the stepper motor 2A (LT), in case of using the feed screw A30 the stepper motor 4.5A (HT) will be supplied. Also a screw A20 can be connected to the HT motor.

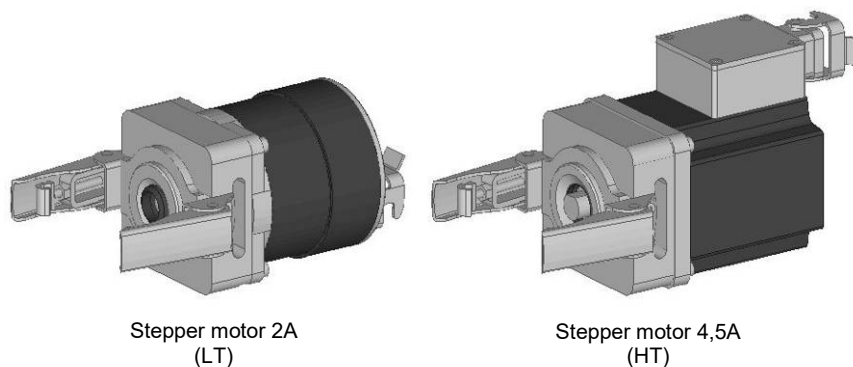

ⓘ Do not select the HT motor if LT motor is connected. This will damage the motor. If LT motor is selected and HT motor is connected there will be less motor torque and this can influence the dosing.

The controller of the dosing unit makes a distinction between two groups of materials, normal granules and micro granules. To determine the kind of material in your application use the description below.

**Material types**

**Normal Granules:  
(NG)**

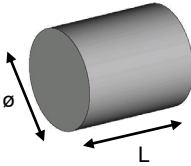

$\varnothing < 0.2 \text{ in. } \{4 \text{ mm}\}$   $L < 0.2 \text{ in. } \{4 \text{ mm}\}$  \*

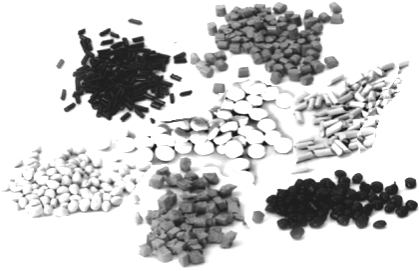

**Micro / Mini Granules:  
(MG)**

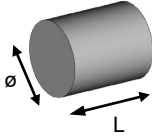

The term Micro/Mini Granules also includes free flowing powder.  $\varnothing < 0.1 \text{ in. } \{2.5 \text{ mm}\}$   $L < 0.1 \text{ in. } \{3 \text{ mm}\}$  \*



\* For other sizes contact a Conair representative.

The actual capacity of the dosing system depends on:

- The volume weight of the material (*bulk density*)
- The specific weight of the material (*specific density*)
- The granular shape of the material
- The granule size
- The surface structure of the material

Granular material can be normal or micro. The granular material and powder material has to be free flowing, non-static and not sticky.

# 6. Installation

## 6.1 Transport

To protect the Conair unit against damage during transport, the unit is packed in a cardboard box filled with polyurethane foam. Delivery terms are Ex-Works Sneek, The Netherlands. Buyer is responsible for the transport. Conair cannot be held liable for any damage during transport.

## 6.2 Receipt

Check the unit thoroughly upon receipt. Pass any remarks to the local agent or Conair within 8 days upon receipt of goods.

## 6.3 Mechanical Installation

Most mechanical parts are pre-assembled, making installation quick and simple.

1. When installing a foreign main material hopper on top of the neckpiece, the **top flange** of the NST40 neckpiece need to be adapted. The lid of the neckpiece can be dismantled for easy machining.
2. - Install the neckpiece directly on top of the entrance of the production machine.  
- Install the neckpiece in a **90-degree** angle to the machine barrel. This will optimize the dosing accuracy in relation to vibrations of the production machine.  
- Make sure that the complete unit is mounted **horizontally leveled** and fixed securely.  
- Assure proper grounding to control cabinet, neckpiece and dosing unit.
3. Connect the **hopper assembly** to the neckpiece by turning the **curled knob** clockwise. Make sure that the curled knob is tightened firmly.
4. Mount the controller vibration free and conform specified temperatures.

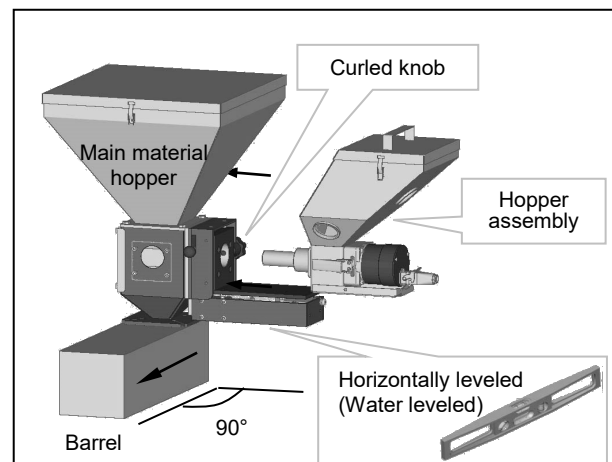
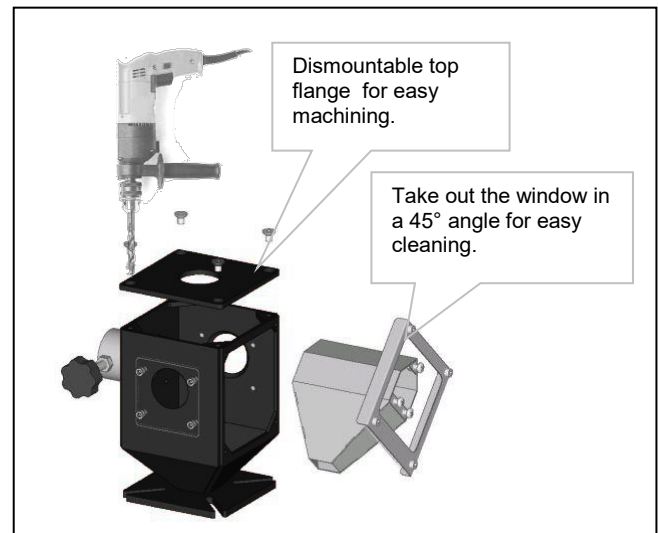

Install the throat adapter at a 90-degree angle to the machine barrel. As shown in the picture above.

## 6.4 Electrical installation

The TrueFeed controller is standard equipped with 3 connections:

- Main power cable
    - ① Before switching on the unit for the first time, ensure the main power voltage being applied is between 80 and 260Vac.
  - Input cable
  - Motor cable (not for MCWeight application)
- ① Be aware that the cables will not be influenced by external circumstances as electromagnetic fields!
- ① Mount the controller on a place which is vibration free and is not a hot surface.

Optional are:

- Alarm flash light, complete with cable
- Compressed air solenoid valve complete with cable (for automatic hopper loader)

# 7. Operation

## 7.1 The Interface

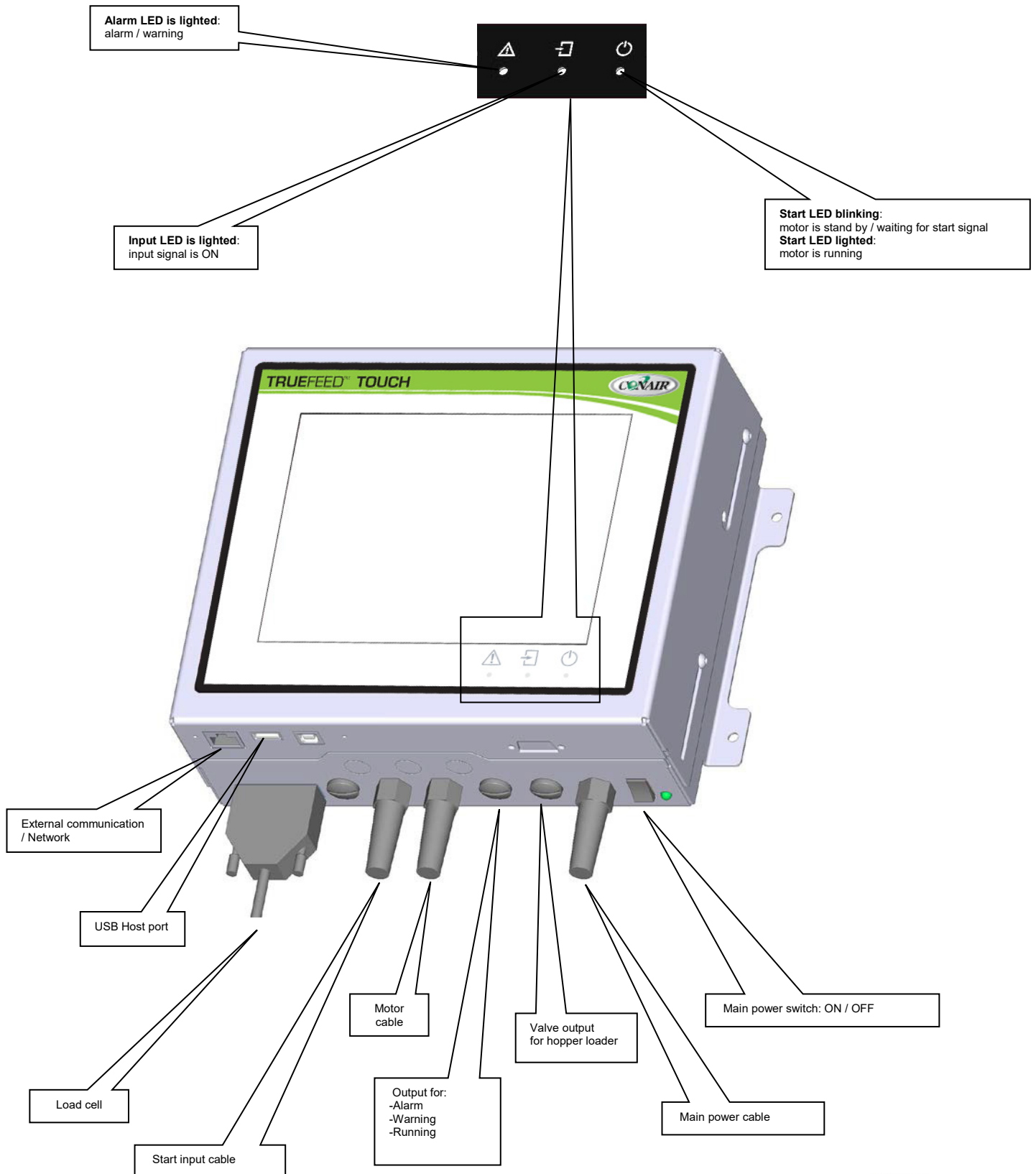

## 7.2 Start-up & Login

After switching on the main power of the TrueFeed, the screen will remain black for about 15 seconds, followed by various screens where the last is showing the software version.

After about 90 seconds the home screen appears.

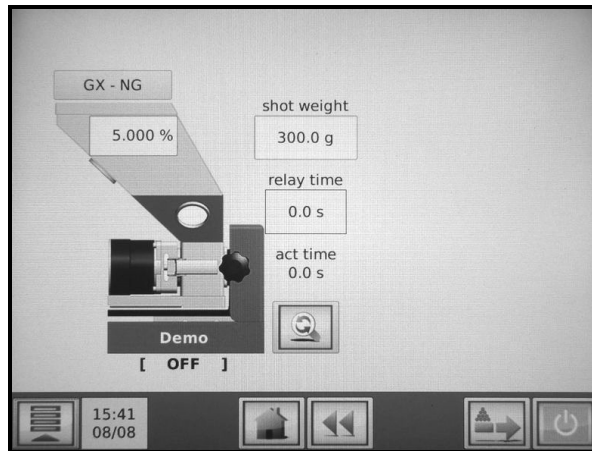



The TrueFeed controller has three user levels:

1. Operator
2. Tooling
3. Supervisor

The functions which are accessible per user level are shown in the table below.

The operator level is the standard level; only the important settings for production can be done. The rest of the settings / menus are invisible or locked.

For changing to another user level, press on the menu icon  (left bottom corner) and the user button appears.  When pressing the user button, the login menu is entered.

Press the LOGIN button and enter the password (4 numerals) and confirm. The passwords for the Tooling and Supervisor user levels can be defined by the supervisor in the ADVANCED CONFIGURATION  menu.



		USER LEVEL Can be changed in LOGIN menu.		
Function	Description:	SUPERVISOR Default code 2222	TOOLING Default code 1111	OPERATOR Default code 0000
[LOGIN]	To enter the different user levels.	YES	YES	YES
[CONFIGURATION]	To configure the dosing system.	YES	YES	NO
[PRODUCTION]	To do the production settings. *In OPERATOR level jobs and materials are read only.	YES	YES	YES*
[HOPPER LOADER]	To do the hopper loader settings, only visible when a hopper loader is selected.	YES	YES	NO
[LEARN]	To learn material properties, only visible when control mode is set to GRAVI (Gravimetric).	YES	YES	NO
[LOAD CELL]	To calibrate the load cell.	YES	YES	NO
[WEIGHT CHECK]	To check the hopper or object weight.	YES	YES	NO
[ALARMS]	View of the alarm history	YES	NO	NO

 Recommended to note the passwords!

Forgot your supervisor password, enter the overall supervisor password **1689**.

When entering a wrong password the user level will be set automatically to operator level.

### 7.3 Configuration

For initial setup the TrueFeed controller needs to be configured in the CONFIGURATION menu. The configuration menu can be entered by pressing the menu button  in the home screen, followed by the configuration button .

First page is the device configuration menu.

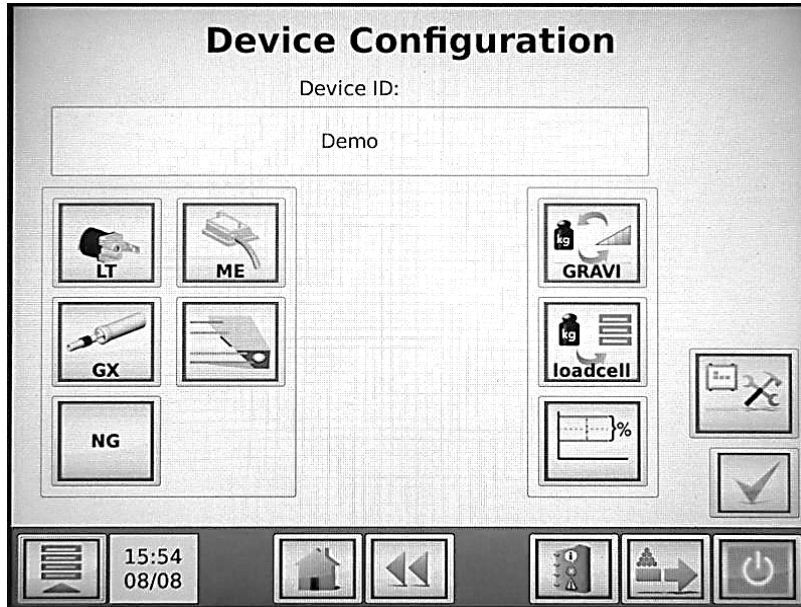

The buttons on the left side are used to select the correct device setup.

 Highlighted Parameters are factory settings.

- Motor type** : LT / HT
- Cylinder type** : GX / GLX / HX / A15 / A20 / A30
- Material type** : NG / MG
- Fill. System** : NO / ME / MV / EX
- Hopper levels**
  - ↳ EX HH level : 3500 gr.
  - ↳ EX H level : 2500 gr.
  - ↳ Filling start : 800 gr.
  - ↳ Hopper empty : 700 gr.

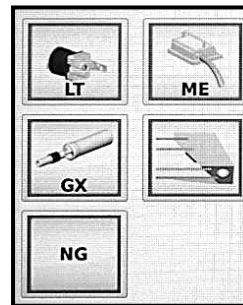

Using the 3 buttons in the right you can change the control mode, perform a loadcell calibration or do a weight check and change the tolerance settings.

- Control mode** : GRAVI / RPM
- Loadcell**
  - ↳ Calibration
  - ↳ Weightcheck
- Tolerance settings**
  - ↳ Deviation alarm : 25 %
  - ↳ Calibration dev. : 5.0 %



When pressing the advanced settings button,



located on the right, the following settings can be changed.

**Language** : ENG / DE  
**Prod. Mode** : INJ / EXT  
**Input type** : Timer / Relay / Tacho  
**Auto start** : OFF / ON  
**Recipe function** : OFF / YES  
**Start login** : Operator / Tooling / Supervisor  
**Tooling passw.** : xxxx 1111  
**Supervisor passw.** : xxxx 2222  
**IP address** : xxx . xxx . xxx . xxx (For example: 192.168.001.001)  
**Modbus address** : 1-231  
**Date / Time** : (dd / mm / yy) (hh / mm)  
**Number of contr.** : 1

### **Configuration: Motor type**

LT is Low Torque motor and HT is High Torque motor (see chapter 5 for more information)

ⓘ Do not select HT motor if LT motor is connected.

### **Configuration: Cylinder type**

Type of dosing cylinder / feed screw (see chapter 5 for more information)

### **Configuration: Material type**

Type of material, normal granules (NG) and micro granules (MG).

(see chapter 5 for more information)

### **Configuration: Fill. System**

Filling system, NO (None), ME, MV or EX (see chapter 7.8)

### **Configuration: Filling start**

Function: When it is detected that the hopper is running empty the filling system will switch on. The filling system will start loading when the weight in the hopper is 800 grams (default) or less. The default value can be changed manual if necessary (depending on the material properties). Also with EX hopper loader selected this is the weight level for opening the knife gate valve to fill the hopper.

ⓘ Only visible when a filling system is selected.

### **Configuration: EX-H level**

The filling knife gate valve will close if the weight in the hopper is 2500 grams (default) or more.

ⓘ Only visible if EX (External / foreign) hopper loader is selected.

### **Configuration: EX-HH level**

HH level is High level warning. If the weight in the hopper reaches 3000 grams (default) or more a warning will be given.

ⓘ Only visible if EX (External / foreign) hopper loader is selected.

### **Configuration: Hopper empty**

The system will give an "Low hopper level" message if there is less than 700 (default) grams of material in the hopper. For this system to work correctly it is necessary that the load cell calibration is done with an empty hopper and the hopper lid in place. This system will always be active.

The default value can be changed manual if necessary (depending on the material properties).

See also chapter 7.12 for how to set this message to alarm or warning.

### Configuration: Control mode

(GRAVI) Gravimetric mode or (RPM) Rotating mode

- Gravimetric mode is set as default and operates on the base of loss-in-weight principle. The output is measured and regulated continuously by controlling the motor speed.
- Volumetric mode (RPM) can be used if no automatic feedback of the weight is required. The weighing will not function in this mode and also the automatic hopper loader function will not work.

### Configuration: Deviation alarm

Setting for the “Maximum deviation exceeded” message.

The TrueFeed automatically adjusts his motor speed to the desired setpoint. The controller is able to detect and alarm when the setpoint is not reached within a set percentage. If after the normal performed speed adjustments the setpoint is consistently not reached, the controller will give an alarm signal and message in the display.

If the setpoint it not reached within the set percentage this can be caused by:

- Partial or complete blockage by sticky or hard flowing material.
- Inaccurate dosing because material is not uniform in size.
- Disturbance of the weight signal, for example by mechanical blocking of the TrueFeed loadframe.

The Maximum deviation setting can be set in the CONFIGURATION menu:

Deviation alarm:      xx%    (1-99%)

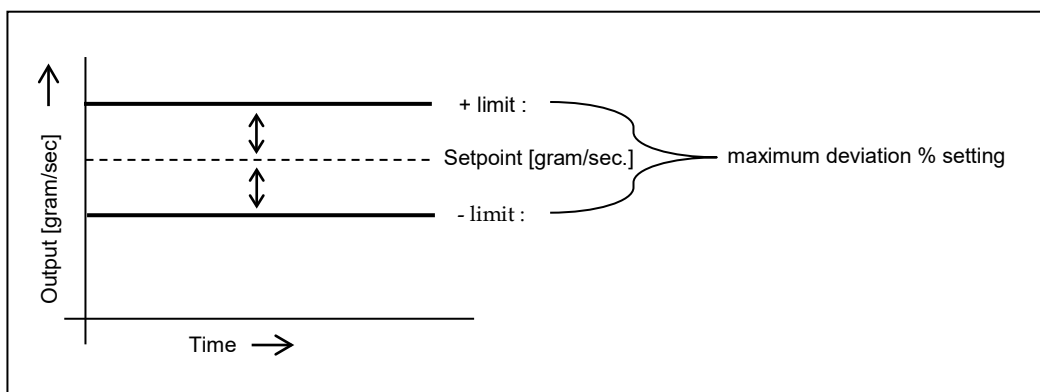

#### Example:

The Deviation alarm setting in the CONFIGURATIONS menu is set to 25% as default.

The setpoint (color set) is set to            : 2.2 lb/sec {1,000 g/sec}  
-the MAXIMUM limit value will be        : 2.7 lb/sec {1,250 g/sec}  
-the MINIMUM limit value will be        : 1.6 lb/sec {750 g/sec}

When the maximum deviation message (Error 08) appears in the display of the controller it shows the measured deviation in percentage of the setpoint.

### Configuration: Cal dev.

The maximum allowed deviation from the Calibration Setpoint can be set with this parameter. (For more information see chapter 7.5)

### Configuration: Language

Standard language is English. Contact Conair for additional languages.

### Configuration: Prod. mode

Production mode

Selection of the machine on which the TrueFeed is placed.

(EXT) extruder or (INJ) injection molding

### Configuration: Input mode

Type of input signal. Relay, Timer or Tacho

Timer mode is the standard setting for Injection molding.

	EXT		INJ	
timer			X	X
relay	X	X	X	
tacho	X	X		
	GRAVI	RPM	GRAVI	RPM

- ① For INJ in timer mode the start pulse should be min. 0.2 seconds.  
For INJ in relay mode the start signal should be as long as the dosing time.

If INJ-Relay is selected the dosing machine will follow the machine relay time.  
The controller will filter small changes out so that the regulation is not being influenced.  
Big changes will be followed.  
The screen shows the real machine relay time.

### **Input (start) signal**

The TrueFeed needs an input signal from the production machine in order to operate.  
Three different input signals can be used to control the TrueFeed.

- 1.) ***A potential free relay contact.***  
Use the white and brown wire for the potential free contact.
- 2.) ***A relay signal 24 Volt DC\*.***  
In case of a powered relay signal connect the white wire to +24 VDC and the yellow wire to the 0 VDC.  
\* Note potential contact  
Guaranteed OFF: 0-8VDC  
Guaranteed ON: 18-30VDC
- 3.) ***A tacho signal up to 30 Volt DC.***  
This is used when the TrueFeed needs to be connected to an extruder that has a tacho generator that produces a voltage linear to the extruder speed. When using a tacho generator signal, make a connection between the white and brown wire. It will function as a start signal. Connect green to + VDC and yellow to the - side of the generator.

The maximum voltage that can be applied to the TrueFeed is 30 VDC. The tacho voltage has to be reduced to 30 VDC if the tacho generator has a higher voltage output than 30 VDC at the maximum extruder output capacity. See the diagram below.

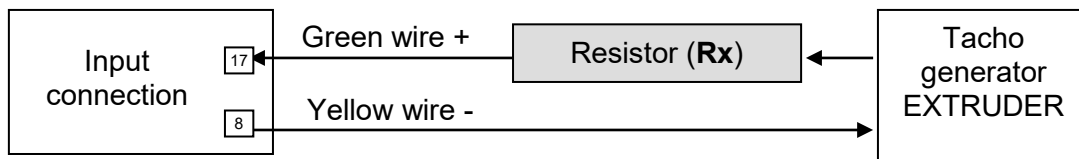

$$R_x \text{ (kilo-Ohm)} = (2.684 \times (\text{Max. tacho output VDC} - 5)) - 66$$

If the extruder stops when connected to the metering unit, an isolated signal converter is needed.  
Contact a Conair representative for more information.

### ***Tacho function***

The tacho function is only available in extrusion mode.

This function can be used with extrusion when it is necessary that the dosing rate is automatically adjusted to the extruder speed. In tacho mode an input voltage is linked to a dosing speed setting. If the extruder speed changes, the tacho input voltage and speed of the dosing unit will change accordingly.

A linear correlation between extruder speed (tacho input signal) and the needed dosing speed is assumed. See graph.

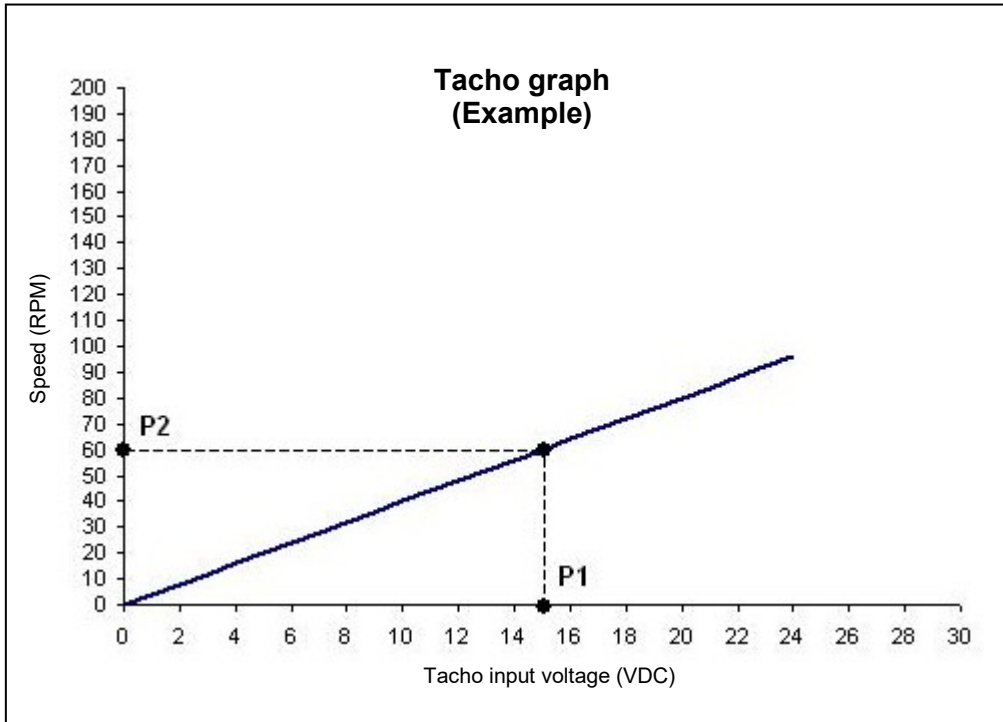

The tacho function can be set in the PRODUCTION screen.  
Tacho can be set manually or be synchronized:

**Manual:**

Fill in the voltage the tacho produced by the tacho generator at maximum extruder speed.

**Synchronize:**

Let the extruder run and select synchronize.

The tacho voltage P1 will be taken over automatically, enter the actual extruder capacity. This is linked to the set motor speed P2 (in RPM mode) or calculated motor speed (in GRAVI mode)

During production, the motor speed P2 can be changed. The new speed is linked to the previous stored voltage and the graph will change accordingly.

During production, the voltage P1 can be adjusted to the current tacho input voltage (manually or automatically) as shown above. The new voltage is linked to the previous stored speed and the graph will change accordingly.

-The maximum voltage that can be applied to the TrueFeed is 30 VDC.

-The tacho signal must be a clear signal. Any failure in the voltage signal will be followed by dosing variations.

**Configuration: Auto start**

Enable / disable auto startup after Voltage dip or main power has been switched OFF.

When enabled the unit will continue dosing automatically after a Voltage dip or main power has been switched OFF.

**Configuration: Recipe function**

Enable / disable recipe functionality

**Configuration: Start login**

User level to start up with, when switching on the controller's main power.

Operator, Tooling or Supervisor.



**Configuration: Tooling passw.**

Password for Tooling user level, 4 numerals, default 1111

**Configuration: Supervisor passw.**

Password for Supervisor user level 4 numerals default 2222

**Configuration: IP address**

IP-address for use in a network environment (TCP/IP protocol). (For example 192.168.001.001)  
When a TrueFeed control is part of a network, the controller must have an IP-address for identification.

ⓘ This IP-address has to correspond with the IP-address of your computer. Ask your network administrator for a unique address.

**Configuration: Modbus address**

If the controller is used in a Modbus network, the unique identity can be filled in here (1-231)

**Configuration: Date / Time**

Actual date (dd / mm / yy), Actual time (hh / mm)

**Configuration: Number of controllers**

Select the number of dosing units (1/2)

**Configuration: Name**

Give a name or figures for individual identification (for use in network).

For example the name of the machine the dosing unit is mounted on.

ⓘ Date and Time will be stored for minimal 1500 hrs. with controller switched OFF.

## 7.4 Production

① The rotation direction of the dosing at the front view must be to the right 

When all configuration settings have been entered production can start. For Injection molding and extrusion the operating differs. Both processes will therefore be explained separately. The production menu can be accessed by pressing the Home button. 

### INJECTION MOLDING

The following parameters can be seen in the production screen, depending on operation or settings:

#### Injection molding / Gravimetric mode

##### Production settings

The production data can be entered by touching the corresponding field

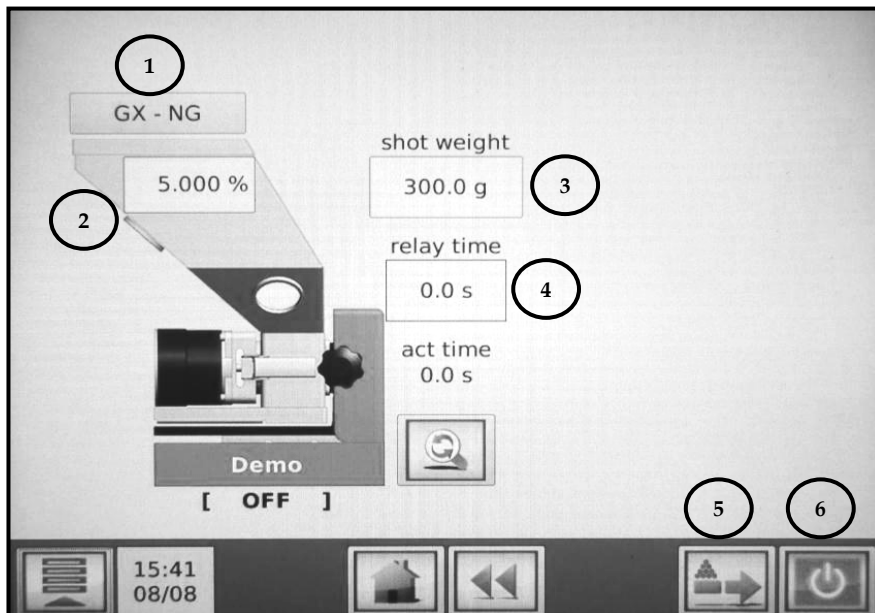

**1. Ref.Curve/material**



Conair pre-programmed curve (dosing tool/granule type), or USER defined curve (material name) is displayed. (not available when recipe function is activated)

**2. Color amount (%)**

**3. Shot weight (gr.)**

**4. Dosing time (sec.)** ① Dosing time only visible in Timer mode, otherwise relay time will be displayed

**5. Prime.** Filling the dosing cylinder before start.

The prime menu appears by pressing . Settings (speed/time) can be changed. Press confirm  to start priming.

**6. Production (Motor On/Off)**

Press  to start dosing. The motor on/off switch will turn from green to red when dosing is started. The start LED blinks when the unit is waiting for an input signal. If the unit is dosing the Start LED lights continuously.

For stopping production press  again. The motor on/off switch will turn to green again.

## Injection molding / Gravimetric mode

### Actual production data

Using the scroll button , one can switch between production settings and production data.

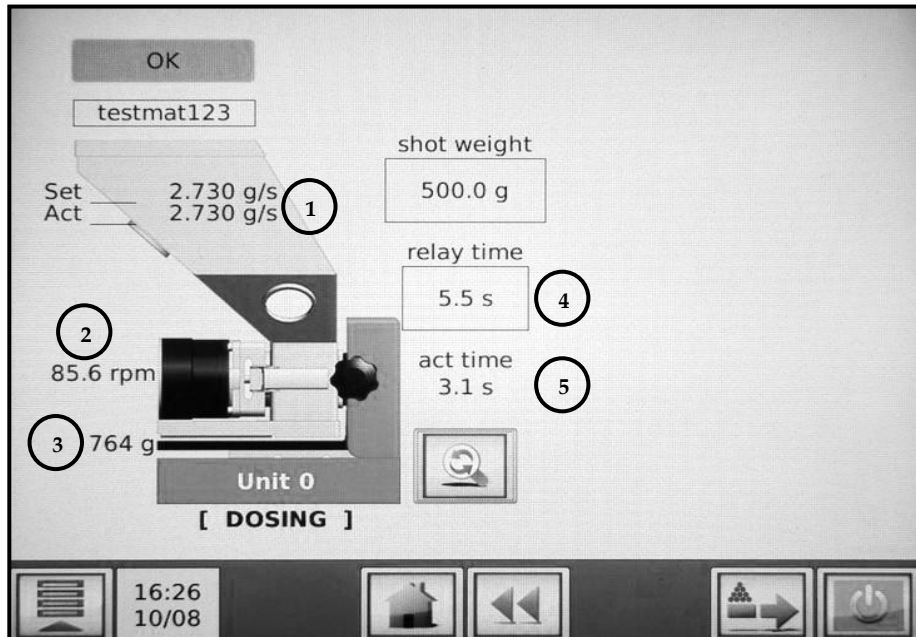

#### 1. Set and actual output.

Set. : Calculated output (gr/sec)

Act. : Actual color output (gr/sec)

① actual color output is only visible after the first automatic RPM adjustment.

#### 2. Speed; Actual motor speed (RPM)

#### 3. Hopperweight ; Material weight in the hopper

#### 4. Time; set dosing time (sec), when working TIMER input mode. Or the average dosing time (sec), when working in RELAY input mode.





#### 5. Act. Time; count down of the actual dosing time (sec)

## Injection molding / RPM mode

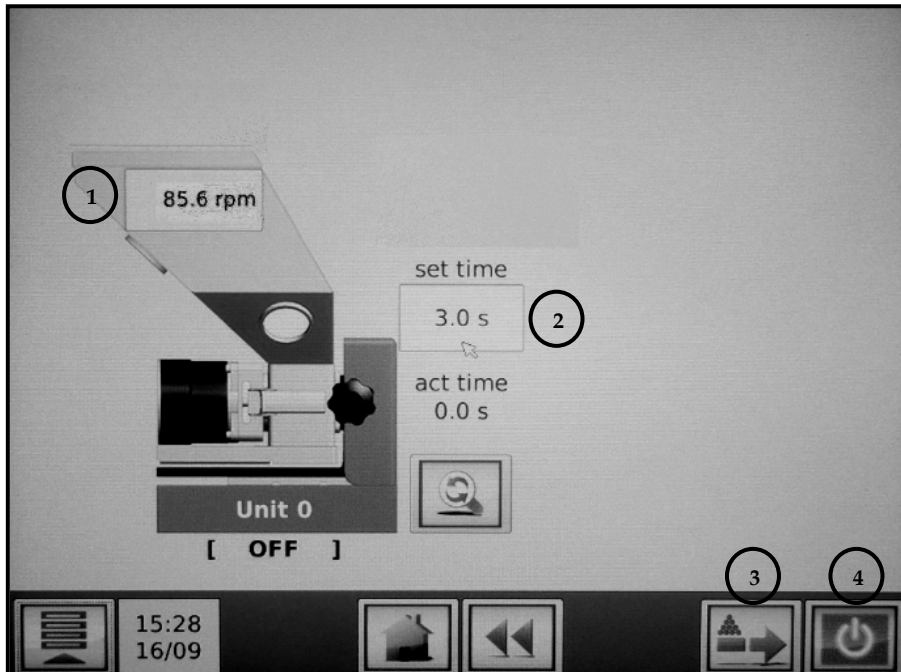
### Production settings

The production data can be entered by touching the corresponding field.



1. **Set motor speed (RPM)**
2. **Dosing time (sec.)**
3. **Prime.** Filling the dosing cylinder before start.  
The prime menu appears by pressing . Settings (speed/time) can be changed. Press confirm  to start priming.
4. **Production (Motor On/Off)**  
Press  to start dosing. The motor on/off switch will turn from green to red when dosing is started. The start LED blinks when the unit is waiting for an input signal. If the unit is dosing the Start LED lights continuously.  
For stopping production press  again. The motor on/off switch will turn to green again.

ⓘ RPM mode needs always a set dosing time, relay function is not functional.

### Actual production data

Using the scroll button  one can switch between production settings and production data.

- **Speed;** Actual motor speed (RPM)
- **Hopperweight ;** Material weight in the hopper
- **Set Time;** set dosing time (sec),
- **Act. Time;** count down of the actual dosing time (sec)

## EXTRUSION

## Extrusion / Gravimetric mode

### Production Settings

The production data can be entered by touching the corresponding field.

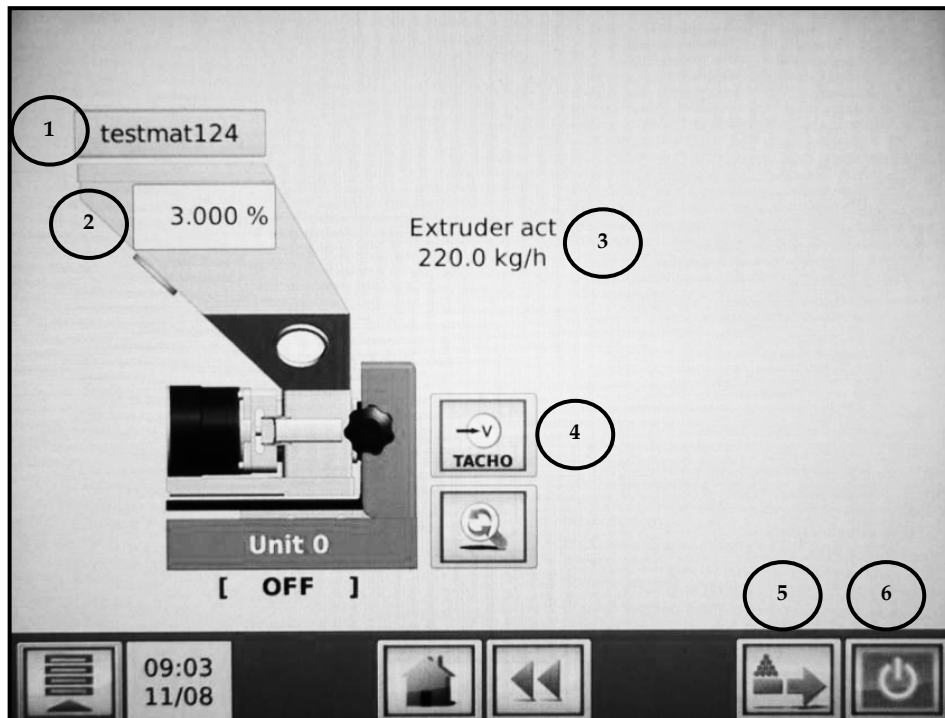

#### 1. Ref.Curve/material

Conair pre-programmed curve (dosing tool/granule type), or USER defined curve (material name) is displayed. (not available when recipe function is activated)

#### 2. Color amount (%)



3. **Extruder capacity (kg/h)**; In tacho mode the actual capacity is displayed. In Relay mode the extruder capacity can be entered.

#### 4. Tacho Voltage. (i only visible in tacho mode)

- **Manual:** Tacho voltage with corresponding extruder capacity can be entered manually.

- **Synchronize:** Tacho voltage can be read from extruder and actual extruder capacity can be entered.

#### 5. Prime. Filling the dosing cylinder before start.

The prime menu appears by pressing . Settings (speed/time) can be changed. Press confirm  to start priming.

#### 6. Production (Motor On/Off)

Press  to start dosing. The motor on/off switch will turn from green to red when dosing is started. The start LED blinks when the unit is waiting for an input signal. If the unit is dosing the Start LED lights continuously.

For stopping production press  again. The motor on/off switch will turn to green again.

## Extrusion / Gravimetric mode

### Actual production data



Using the scroll button , one can switch between production settings and production data.

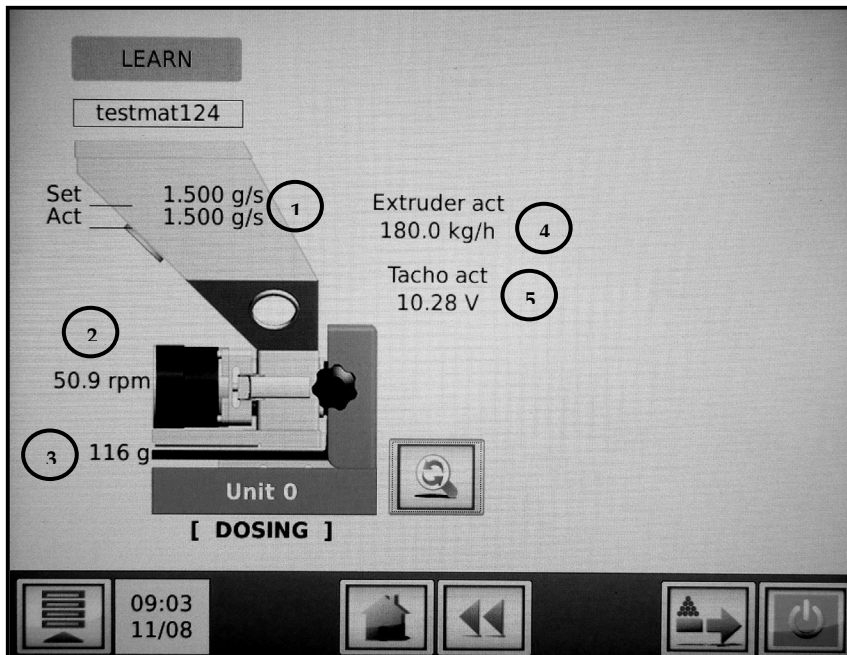

**1. Set and actual output.**

Set. : Calculated output (gr/sec)

Act. : Actual color output (gr/sec)

① actual color output is only visible after the first automatic RPM adjustment.

**2. Speed; Actual motor speed (RPM)**

**3. Hopperweight ; Material weight in the hopper**

**4. Actual extruder capacity (kg/h)** ① Only visible in Tacho mode. In Relay mode the set extruder capacity is displayed.

**5. Actual tacho voltage.** ① Only visible in Tacho mode.

### Extrusion / RPM mode

#### Production Settings

In RPM mode the dosing can be done in relay mode or in tacho mode. In relay mode dosing is done at a set rpm. The rpm of the motor has to be entered manually.

In tacho mode the Tacho voltage with corresponding rpm can be entered manually. Or with the synchronize function the tacho voltage can be read from extruder and corresponding rpm of the dosing unit can be entered.

#### Actual production data

During production the motor rpm, hopper weight, and tacho voltage (only in tacho function) will be displayed.

## 7.5 Save data function

### Save data Function

This function allows storing the actual data during production. A material description needs to be entered to save this data. A full material curve on basis of the stored point will be saved in the memory of the controller under the entered name.

Starting a new production run with a previous stored material calibration/speed is now possible,

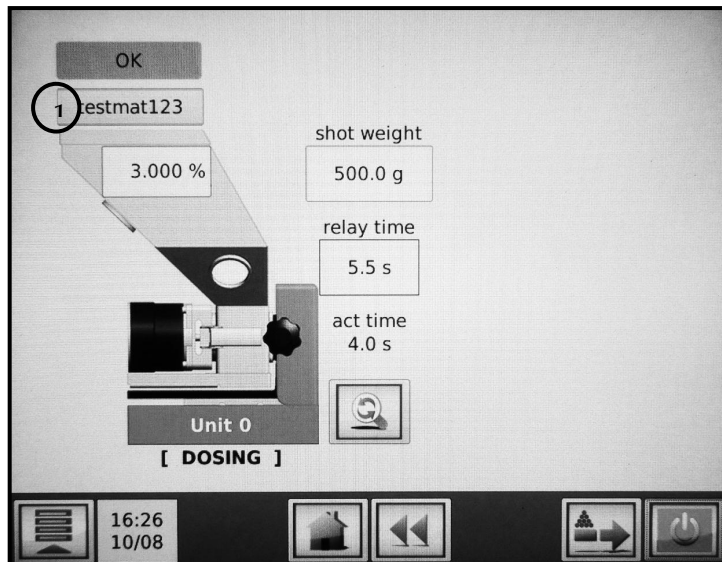

Press on the curve description (1) when the unit is activated. The “SAVE LEARNED DATA” screen appears.

Enter a material description (max.10 positions) and press  to store the material curve.

## 7.6 Filling the hopper

### MANUAL FILLING

The controller automatically detects when the hopper is manual filled. In the period that the hopper is being filled, the TrueFeed is dosing with a fixed RPM, this means the unit runs temporarily volumetric. As soon as the hopper filling is ready, the TrueFeed immediately continues to work gravimetric.

### AUTOMATIC FILLING

- ① Only use Conair hopper loaders to fill the hopper automatically. Foreign hopper loaders can influence the gravimetric function of the dosing.

#### Introduction

Conair dosing units are capable of handling a variety of dry materials. Two different filling systems are available depending on the material properties.

- The Conair Ejector (CE) system for dust-free or nearly dust-free materials
- The Conair Vacuum (CV) system for materials that are NOT entirely dust free.
- The Support frame for external / foreign hopper loaders (EX)

The ME and MV systems are both driven by low-pressure compressed air and mounted directly on top of the hopper lid of the Conair dosing unit. The TrueFeed controls the operation of the ME or MV systems.

All parts are aluminum or stainless steel and are virtually maintenance-free. Only the filter needs to be cleaned periodically. To increase reliability and safety, there are no moving parts except for the pneumatic operated closing valve of the MV system.

#### How the CE works

The CE system blows the material from the bag, drum or container into the hopper of the dosing unit. The hopper lid of the housing has a simple and easy-to-clean dust filter to keep any dust particles in the hopper.

The system is triggered by the filling start weight (DEVICE CONFIGURATION). This parameter also generates a low-level alarm if the hopper is empty.

ME hopper loader

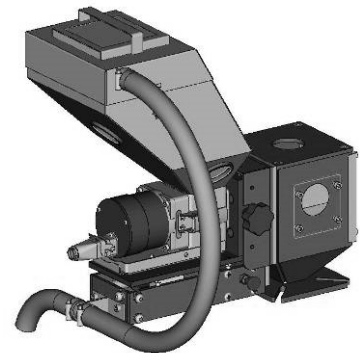

#### How the CV works

The MV system uses a 3-stage vacuum generator driven by compressed air to create a vacuum that draws material into a chamber that closes. Once the chamber is filled with material, the cone that closes the chamber will open and the material will be discharged into the hopper.

The system is equipped with a superior filter to ensure that the finest particles (> 5micron) stay in the system and are not released into the atmosphere. This makes the MV system the most practical and user-friendly system for both powders and granules.

MV hopper loader

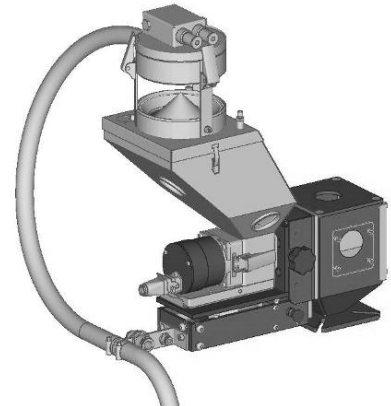

### How the EX (support frame for External hopper loader) works

The function of the support frame is to use a foreign hopper loader in combination with the TrueFeed. The support frame is equipped with a knife gate valve for filling the hopper. The valve is normally closed. If the filling start level is reached (default 800gr.) The valve opens and the hopper is filled until the EX-H level (default 2500gr.). Then the valve will close automatically, so the support frame works independently from the hopper loader. If for some reason the weight reaches the EX-HH level a warning will be given. This can happen if for example the valve doesn't close.

**⚠** Do not take the dosing unit away before the compressed air of the valve is disconnected and press **STOP**  on the controller to disable the valve because the knife gate valve can move!

**i** It could be necessary to use an customer specific intermediate plate between the hopper loader and the support frame to make a good fit.

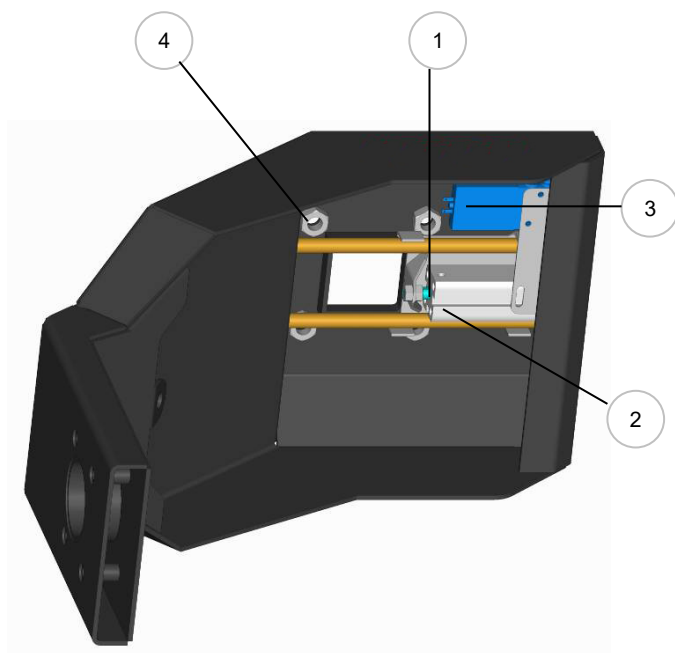
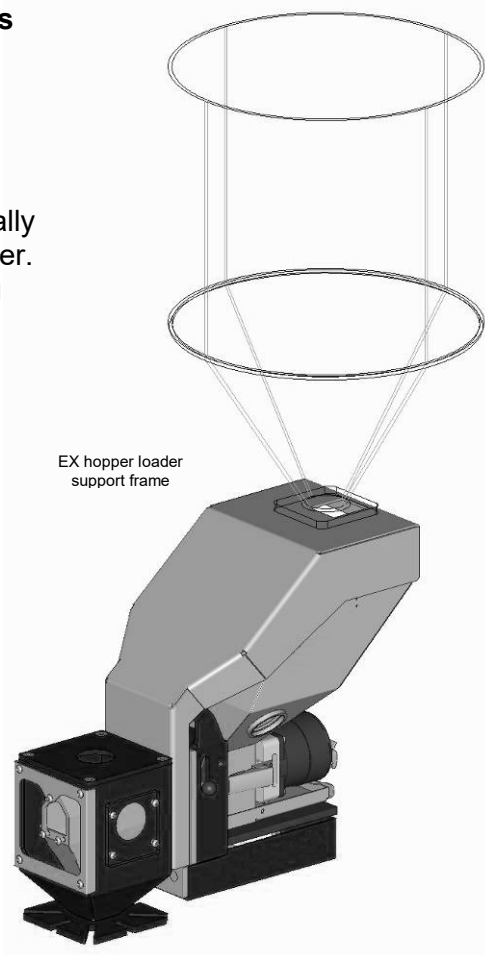

1	Knife gate valve
2	Cylinder for open/close the valve
3	Solenoid valve
4	Connection Nuts (M10) for hopper loader mounting

## General

① The hopper loader is only activated when the motor is On.

① Emergency stop.

To stop the hopper loader the motor must be switched off. In the device configuration menu the ME/MV/EX can then be switched off.

## Hopper loader settings

This part of the manual describes how to configure the hopper loader. For further technical information about the hopper loader consult the specific hopper loader manual.

There are four ways to fill the hoppers:

1. Manual
2. Automatic with ME hopper loader
3. Automatic with MV hopper loader
4. Automatic with EX external hopper loader in combination with the support frame.

## Manual

Open the hopper lid and fill the hopper by hand. (filling will be detected automatically)

The warning message "Low hopper level" appears when the material level in the hopper is below the set level. (default 800 gr.)

The levels settings for the hopper loader can be checked and adjusted if necessary. Enter the device configuration menu and press.  The available settings vary per loader model.

## ME hopper loader (Conair hopper loader operated by compressed air)

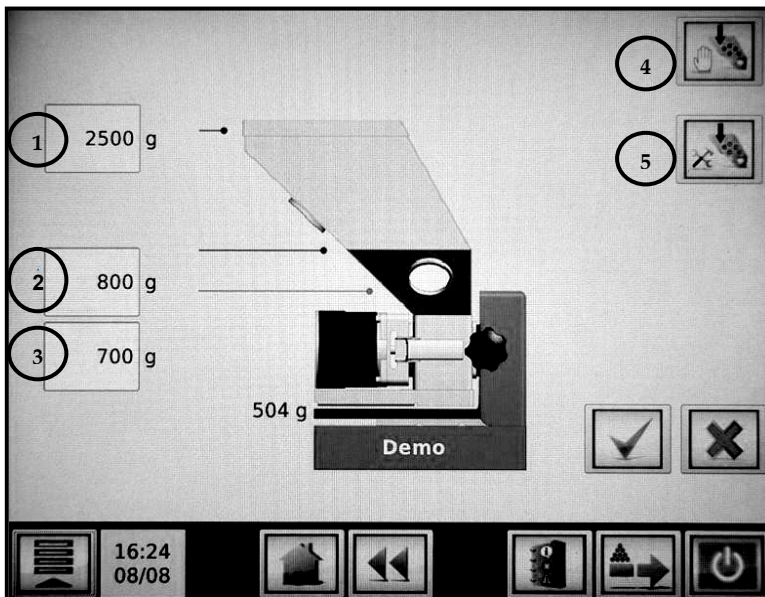

1. = Max filling level
2. = Hopper loader start level
3. = Hopper empty level
4. = Manually activate the hopper loader.  
The Manual filling function can for example be used to fill the hopper before start of production.
5. = Advanced loader settings.

In the advanced loader settings menu alarm time and alarm mode can be changed.

Alarm time: Fill Alarm [sec.], if the hopper weight is not above the 800gr. within this time, the alarm starts. The alarm time cannot set lower than the fill time.

Alarm mode: ME hopper loader is ON / OFF during fill alarm.

ON = ME Hopper loader stays activated during a filling alarm.

OFF = ME Hopper loader will be deactivated during a filling alarm.

## MV hopper loader (Conair hopper loader operated by vacuum)

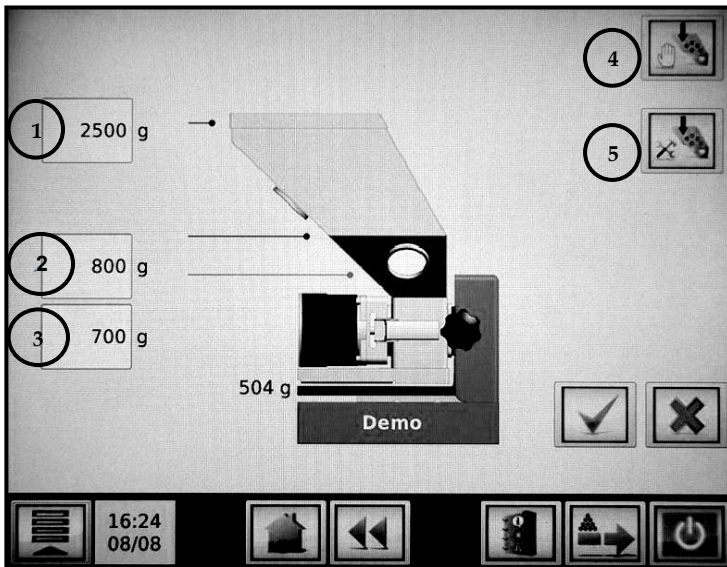

- 1 = Max filling level
- 2 = Hopper loader start level
- 3 = Hopper empty level
- 4 = Manually activate the hopper loader.  
The Manual filling function can for example be used to fill the hopper before start of production.
- 5 = Advanced loader settings.

In the advanced loader settings menu Fill time, empty time, alarm time and alarm mode can be changed.

**Fill time:** Fill time [sec.], during this time the MV system sucks material into the vacuum chamber.

**Empty time:** Empty time [sec.], during this time the cone that closes the chamber will open and material falls down into the hopper of the dosing unit.

**Alarm time:** Fill Alarm [sec.], if the hopper weight is not above the 800gr. within this time, the alarm starts. The alarm time cannot set lower than the fill time.

**Alarm mode:** MV hopper loader is ON / OFF during fill alarm.

ON = MV Hopper loader stays activated during a filling alarm.

OFF = MV Hopper loader will be deactivated during a filling alarm.

### EX hopper loader (support frame for external hopper loader)

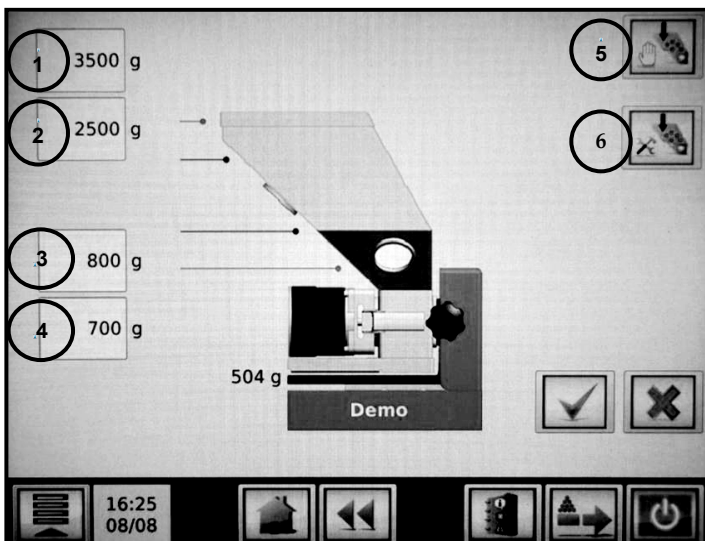

- 1 = The *EX-HH level* is the Highest level. If this level is reached a "High level" warning appears.
- 2 = *EX-H level* is the level where the knife gate valve will be closed again.
- 3 = Filling start level
- 4 = Hopper empty level
- 5 = Manually fill.
- 6 = Advanced loader settings.

In the advanced loader settings menu alarm time and alarm mode can be changed.

**Alarm time:** Fill Alarm [sec.], if the hopper weight is not above the 800gr. within this time, the alarm starts. The alarm time cannot set lower than the fill time.

**Alarm mode:** EX hopper loader is ON / OFF during fill alarm.

ON = EX Hopper loader stays activated during a filling alarm.

OFF = EX Hopper loader will be deactivated during a filling alarm.

## Output signals

During fill time there will be a 24VDC signal between connection 29 and 30 on the main board to activate the pneumatic solenoid valve.

When the Fill Alarm is activated there will be a 24VDC signal between connection 27 and 28 on the main board to activate the flash light. The controller itself gives a beeping signal and the alarm LED will light up.

## GENERAL RECOMMENDATIONS FOR OPTIMAL HOPPER FILLING

To guarantee the optimal working of the gravimetric TrueFeed dosing unit it is important to use the correct rate of hopper filling. The higher the output of the dosing unit (kg/h), the more important becomes the rate of hopper filling.

During hopper filling, the electronics of the TrueFeed controller recognize automatically that the hopper is being filled. This automatic filling detection is working for manual filling of the hopper and filling with an automatic hopper loader.

In the period that the hopper is being filled, the TrueFeed is dosing with a fixed RPM, this means the unit runs temporarily volumetric. As soon as the hopper filling is ready, the TrueFeed immediately continues to work gravimetric.

Because the TrueFeed is working volumetric during a hopper filling it is recommended to reduce the amount of filling cycles. Or in other words, to enlarge time between a filling moment and the next filling moment. This can be performed when using the correct settings of the "Filling start level" and the "Filling stop level".

When the unit is started with the auto start function enabled and the unit is switched OFF and ON again the filling will start automatically if the hopper weight is too low.

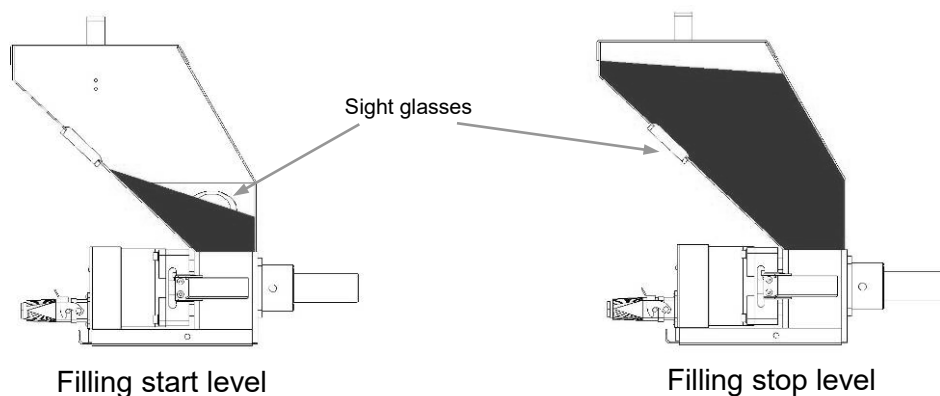

The moment when the automatic filling starts depends on the entered start level:

*Filling start : xxx gr. (configuration menu)*

Filling stop level is depending on the entered fill time for the ME-system:

*Fill time : xxx sec*

For the MV-system:

*Fill time : xxx sec*

*Empty time : xx sec*

*Fill cycles : .... x*

*(hopper loader menu)*

## Recommended settings for ME hopper loader:

-Use for the filling start weight a level like shown in the filling start figure above, when using a too high weight level the amount of filling cycles will increase.

-Use a fill time so that the material covers at least the sight glass in the back of the hopper. Overfilling of the hopper should be avoided

### **Recommended settings for MV hopper loader**



- Use for the filling start weight a level like shown in the filling start figure above, when using a too high weight level the amount of fill cycles will increase.
- Use a fill time so that the vacuum chamber of the MV-Loader is filled almost completely. Overfilling of the vacuum chamber should be avoided.
- Use for the empty time not a longer time that necessary but a short empty time can cause decrease of the capacity of the MV-hopper loader.
- For the amount of filling cycles use an amount so that the material covers at least the sight glass in the back of the hopper. Overfilling of the hopper should be avoided

### **Recommended settings for EX hopper loader (support frame):**

- The Volume of the hopper is 0.2 ft<sup>3</sup> {6 liter}. To set the EX-H level (stop filling). It is recommended to take a safety margin to prevent the hopper from overfilling.
  - EX-H (gr.) = 0.17 ft<sup>3</sup> {5 liter} x bulk density (gr. /liter)
- For example: If the bulk density = 700 gr. / ft<sup>3</sup> {liter}, the EX-H should be set to 700 x 5 = 3500 gr.  
The EX-HH (gr.) should be set higher, recommended 700 x 6 = 4200 gr.  
Overfilling of the hopper should be avoided because it influences the measurement.

## 7.7 Alarms

### GENERAL

To reset an alarm / warning during production press  to Stop dosing or / and confirm . When an error occurs using the MC-TC, the display will indicate an error code and description. Together with the displayed error an output contact will be switched. The controller itself gives a beeping signal and the alarm LED will lighten up. 

Warning vs. Alarm:

**Warning:** Warning output is ON, but the dosing unit continues running (24VDC contact, pin 27-28 of the main board will be active, for example to activate the flash light,)

**Alarm:** Alarm warning output is ON and the **dosing unit stops running** (24VDC contact, pin 27-28 of the main board will be active, for example to activate the flash light,)(Potential free contact, pin 32-33 of the main board will be active, for example to stop the Injection molding machine or extruder)

Free programmable errors can be configured to an **Alarm** or **Warning**.

For setting the free programmable outputs into alarm or warning, enter the ALARMS menu. The alarm menu can be accessed in the advanced configuration menu.

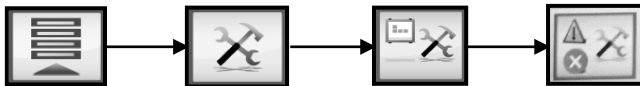

In the alarm configuration menu a list of warnings/alarms is displayed



Here you can select if the alarm- or warning output should be activated by pressing on the warning symbol .

The alarm history can be opened through the home screen by pressing  (not in operator mode). A list with the alarms that occurred will appear. (UNDER CONSTRUCTION)

<u>Code</u>	<u>Warnings</u>	<u>Description</u>
1	Filling system unable to load material	Fill system is not working correct
2	Low level	Material is below the hopper start filling weight
3	Empty level	Material is below the hopper empty weight
4	High-High level	Hopper weight has reached the EX-HH level
5	Minimum motor speed (< 0.1 RPM)	Calculated motor speed is too low
6	Maximum RPM exceeded, change dosing tool for higher capacity	Calculated motor speed is too high
8	Maximum deviation exceeded!	The deviation of the material output is too high
10	Master /slave connection failure!	Connection failure between multi component controllers

We have the following Errors:



#### Alarms

100	Motor connection failure!	Motor not connected / Motor or connection damaged
102	Load cell connection failure!	Load cell connection is not correct

## WARNINGS

All **warnings** are self-eliminating.

It is possible to cancel a warning, but when the error remains, the warning will return after 60 seconds. This gives the operator the time to solve the problem without having the alarm on.

<b>Error 01</b>	<p><b>“Filling system unable to load material”</b> If this warning appears the alarm time (ME hopper loader) or alarm cycles (MV hopper loader) are exceeded.</p> <ul style="list-style-type: none"> <li>- Check if there is enough material.</li> <li>- Check if the material is stuck somewhere.</li> <li>- Check the operation of the hopper loader.</li> <li>- Check the hopper loader settings.</li> </ul>
<b>Error 02</b>	<p><b>“Low level!”</b> <b>“Level is less than xxx g”</b> If this warning appears the material in the hopper is below the hopper low weight (800 gr.) In DEVICE CONFIGURATION this setting can be changed.</p> <ul style="list-style-type: none"> <li>- Check if there’s enough material in the hopper.</li> <li>- Check the hopper Low setting in DEVICE CONFIGURATION &lt;menu&gt;</li> <li>- Check if the hopper loader is working right.</li> </ul>
<b>Error 03</b>	<p><b>“Empty level”</b> <b>“Level is less than xxx g”</b> If this warning appears the material in the hopper is below the hopper empty weight (700 gr.) In CONFIGURATION &lt;menu&gt; this setting can be changed.</p> <ul style="list-style-type: none"> <li>- Check if there’s enough material in the hopper.</li> <li>- Check the hopper empty setting in CONFIGURATION &lt;menu&gt;</li> <li>- Check if the hopper loader is working right.</li> </ul>
<b>Error 04</b>	<p><b>“High level”</b> <b>“Level is higher than xxx g”</b></p> <ul style="list-style-type: none"> <li>- Check if the knife gate valve is in closed position.</li> <li>- Check if the knife gate is sliding.</li> <li>- Check if the parameters EX-H level and EX-HH level are set OK.</li> </ul>
<b>Error 05</b>	<p><b>“Minimum motor speed (&lt; 0.1 RPM)”</b> Calculated motor speed is lower than the minimum of 0.1 RPM</p> <ul style="list-style-type: none"> <li>- Check if there’s enough material in the hopper.</li> <li>- Check the production settings.</li> <li>- Decrease the dosing time (if possible)</li> <li>- Take another dosing type with lower output, for example a GLX-cylinder </li> <li>- Check the rotation direction of the dosing cylinder. Front view to the right </li> </ul>
<b>Error 06</b>	<p><b>“Maximum RPM exceeded, change dosing tool for higher capacity”</b> <b>“Change dosing tool for higher capacity”</b> Calculated motor speed is higher than the maximum of 200 RPM</p> <ul style="list-style-type: none"> <li>- Check the material output on 200 RPM.</li> <li>- Check the production settings.</li> <li>- Increase the dosing time (if possible)</li> <li>- Take another dosing type with higher output, for example a feed screw A20</li> </ul>
<b>Error 08</b>	<p><b>“Maximum deviation exceeded”</b> If this warning appears the dosing output (grams/sec) is consistently not within set percentage. See page 18 for more information.</p>
<b>Error 09</b>	<p><b>“Master/Slave connection failure”</b> Connection failure between multi component controllers</p> <ul style="list-style-type: none"> <li>- Check wiring.</li> </ul>

## ALARMS

<b>Error 100</b>	<p><b>“Motor connection failure”</b> Motor connection is not correct.</p> <ul style="list-style-type: none"> <li>- Make sure the motor is connected.</li> <li>- Check cable and connectors for damage.</li> </ul>
<b>Error 102</b>	<p><b>“Loadcell connection failure”</b> -Load cell connection is not correct. -Load cell connector is not connected to the controller.</p>

## 7.8 Recipe function

With the MCTC it is possible to store the current production settings into a recipe. All production settings of all components will be stored within this recipe. An easy recall of the production settings is possible by loading the previous stored recipe.

In case of a multi group configuration, one recipe includes all components and all groups.

① The Recipe function must be enabled in the System Configuration screen.

### 7.8.1 Creating a new recipe

From the horizontal menu bar, press the recipe button: 



The Recipe editor screen will appear:

- |   |  |
|---|--|
| 1. <b>Recipe name</b>                     | Enter desired recipe name.   |
| 2. <b>Injection molding<br/>Extrusion</b> | Shot weight.<br>Extruder throughput kg/h.  |
| 3. <b>Injection molding</b>               | (Timer only): Shot time.   |
| 4. <b>Component name</b>                  | Component name (can be set in configuration menu).   |
| 5. <b>Pre-learned material curve</b>      | Select the pre-learned material curve per component.<br>① In case of no pre-learned materials it is recommended to select the Movacolor default curve. |
| 6. <b>Material/component function</b>     | How the material should be treated, regrind, virgin, additive.   |
| 7. <b>Dosing percentage</b>               | Enter dosing percentage per component.<br>① To disable a component (OFF), set the dosing percentage to 0%.   |
| 8. <b>Group selection</b>                 | Select the current group to be edited.<br>① Only visible when more than one group configured.  |
| 9. <b>Save button</b>                     | Save the recipe and load as active recipe.   |
| 10. <b>Cancel</b>                         | Leave this screen discarding all changes.  |

### 7.8.2 Load / edit a recipe

From the horizontal menu bar, press the recipe button:   
The Recipe editor screen will appear. Press the recipe list button (1).

Name:   1

Select the desired recipe by using the up and down buttons:  

 When there is a long list of stored recipes, it can be time consuming to find the recipe. It is possible to search in the list of recipes using the search button. You can enter part of the recipe name you need to search for.

Example, you need to load the recipe named "Recipe RED 1", when you enter "RED" in the search field, all recipes names containing "RED" will be displayed in the list.

Confirm the selection with the accept button: 

The next screen will show the settings of the selected recipe. Here you can check the settings of the recipe.

By pressing the apply button  the recipe will be loaded.

-OR-

Edit the production parameters within the recipe to your needs and save the recipe.

To save the recipe, just press the save recipe button , you will be prompted to overwrite the recipe:

Overwrite current selected recipe (changes in the recipe will be saved).

Do not overwrite, you will be prompted to enter a new recipe name (create a copy/new recipe)

 The new recipe is not immediately selected, go back to the main recipe screen to select the new recipe



A recipe can also be edited from the HOME screen. When a recipe is loaded and a production setting is changed, the recipe button icon will change to the following: 

By pressing this button, you will be prompted to overwrite the recipe, or to store the current settings under a new recipe name.

### 7.8.3 Deleting a recipe

From the HOME screen, press the recipe  button, from the recipe editor screen choose the list button (1).

Name:   1

Select the desired recipe by using the up and down buttons:  

 To delete the selected recipe.

 To delete all recipes in the list at once.

## 7.9 USB menu

The MCTC is equipped with a USB host port. This port can be used for exporting consumption reports, material, recipe and configuration files. Material, configuration, and configuration setting files can also be imported for backup/restore purposes. This USB port is also used for MCTC software updates.

- ① For software updates, contact your local Movacolor representative.
- ① Your USB memory stick should be formatted FAT32.

### 7.9.1 Export and Backup / Restore

Insert your USB memory device into the USB host port ( See chapter: [The Interface](#) )

Press:



The USB menu will be shown, containing 3 options

- |                                      |  |
|--------------------------------------|--|
| 1. Copy files from USB to Controller | Restore files from USB memory stick to Controller. |
| 2. Copy files from Controller to USB | Export files from Controller to USB memory stick.  |
| 3. Remove USB memory stick           | Safely remove USB memory stick.                    |

When choosing option 1 (import) or option 2 (export), a new screen will be shown with the next options:

- |                               |   |
|-------------------------------|---|
| 1. Recipes and Materials      | Transfer of material and recipe files only.                     |
| 2. Configuration and Settings | Transfer of configuration and settings files only.              |
| 3. Consumption Reports        | Transfer of consumption reports only (export only).             |
| 4. All                        | Transfer of all files (materials, recipes, configuration, log). |

After copy of the files to the USB memory stick, you can store the backup files to a network drive or backup folder on your computer. The USB memory stick contains a folder named MC\_TC, this folder contains the transferred files.

### 7.9.2 Remove USB stick

When you are ready with the required USB operations, it is mandatory to press the Remove USB memory stick button prior to unplugging the USB memory stick. You will be prompted when the synchronisation is finished and it is safe to remove the USB memory stick. This synchronizes the files of your USB stick for safe removal.



Risk of damaging the data on your USB memory stick when it is not safely removed.

## 7.10 Screenlock

To avoid any unwanted modification in the production settings by an unauthorized person, the touchscreen can be locked. With this function enabled, you are still able to see actual production data, but you cannot change production settings. To enable and disable the lock function, you need to be logged on with at least TOOLING level.

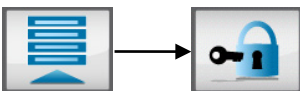

To unlock, follow the same sequence.

## 7.11 Consumption counters

The MCTC is equipped with consumption counters, counting the consumed material of each unit. To reset the consumption counters you need at least TOOLING level login.

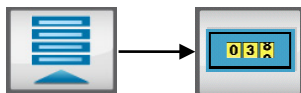

### 7.11.1 Consumption counter by order

Consumption can be counted by order number. By changing the order number all consumption counters will be reset!

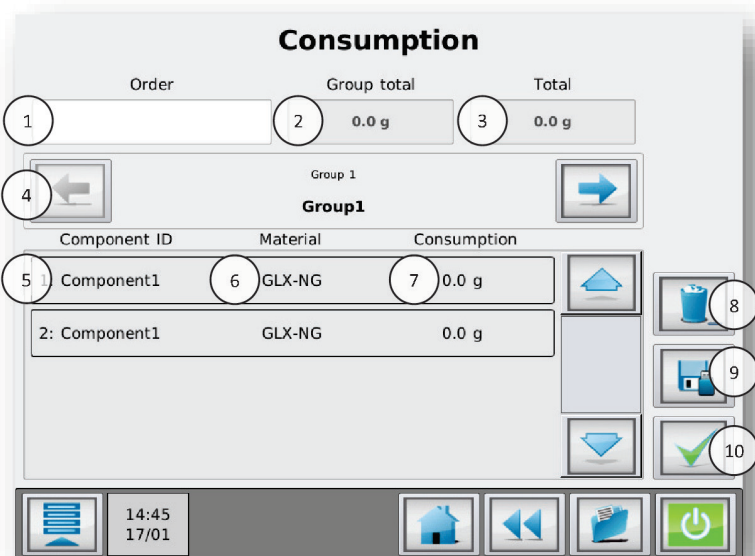

- |   |  |
|---|--|
| <ol style="list-style-type: none"> <li>1. <b>Order number</b></li> <li>2. <b>Group total</b></li> <li>3. <b>Total</b></li> <li>4. <b>Group selection</b></li> <li>5. <b>Component ID</b></li> <li>6. <b>Material</b></li> <li>7. <b>Consumption</b></li> <li>8. <b>Reset</b></li> <li>9. <b>Export Report</b></li> <li>10. <b>Exit</b></li> </ol> | <p>Enter a production order number.<br/> <i>ⓘ</i> Can be left blank, consumption will still be counted. Cannot be filled in afterwards.</p> <p>Total consumption for selected group (sum of all components).</p> <p>Total consumption of the whole machine (sum of all groups).</p> <p>Select the current group to be shown.<br/> <i>ⓘ</i> Only visible when more than one group configured.</p> <p>The ID and name of the components in the current selected group.</p> <p>Material name of current loaded material file.</p> <p>Current component consumption.</p> <p>Reset all consumption counters.</p> <p>Generate a consumption report and export the last 5 to USB memory stick.</p> <p>Leave current screen.</p> |
|---|--|

## 7.12 Material Calibration

### How to start the material curve learn function:

1. Press the material selection button on top of the hopper image.



2. Press the material learn button:
3. Press the material “name” button and enter a material name.
4. Enter the production settings, recommended is to use the same settings as will be used in the final production.

For injection molding:

- the shot weight;
- the dosing time;
- dosing percentage.

For extrusion:

- extruder capacity (production rate);
- dosing percentage.

ⓘ The ideal situation is to choose the same settings as used during actual production, however when the output is too high and the learn function cannot be completed within one hopper filling, choose a lower capacity.

5. Press the start button
6. You will be asked to check:
  - if the motor is connected;
  - the hopper is filled ;
  - if you want to prime the dosing tool, confirm the question.

- The learning will take at least 3 minutes but can take more time depending on the used material and production parameters. It is possible to stop during the learning (for example to refill the hopper). When “Stop & Save” is selected the learning will pause. There are 3 options:



= Stop learning and save the collected data.



= Stop learning without saving.



= Continue with learning.

- The unit will execute the calibration procedure, the procedure will stop when the dosing is within the calibration deviation range (default 5%). The material curve will be stored and is automatically selected for the current component.

During the calibration the unit is regulating to its set point. When this point is reached the calibration will be saved automatically. On the basis of this point a complete curve is made on bases of default preprogrammed curves.

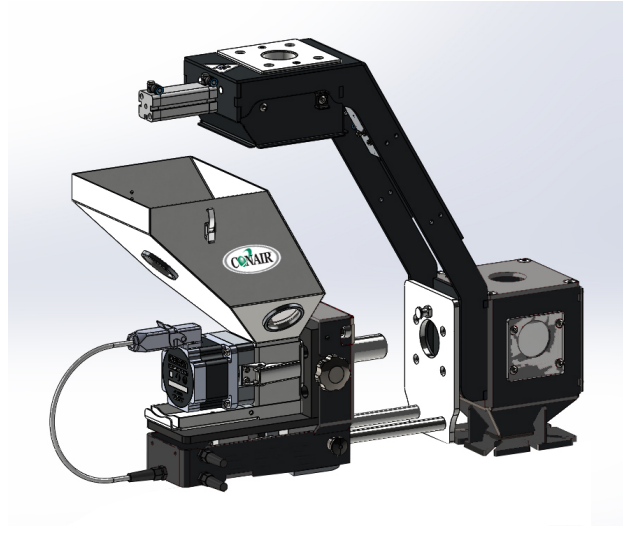
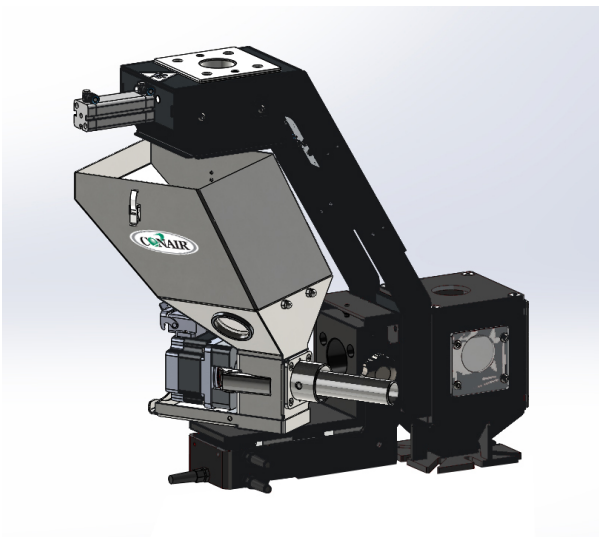

# 8. Dual Station

The TC controller can be used in combination with a BC (Blind Controller) to control a dual station. This is for use of dosing 2 components in one neckpiece. With the Touch panel both dosing units can be controlled.

## 8.1 Electrical installation

A dual station consists of a touch control panel and a blind control box. Both have their own main power and motor cable. They are connected with each other through a can bus connection. Standard names are “Unit 0” for the unit connected to the touch control box and “Unit 1” For the unit connected to the blind control box. Input for both units is done via the input cable of Unit 0.

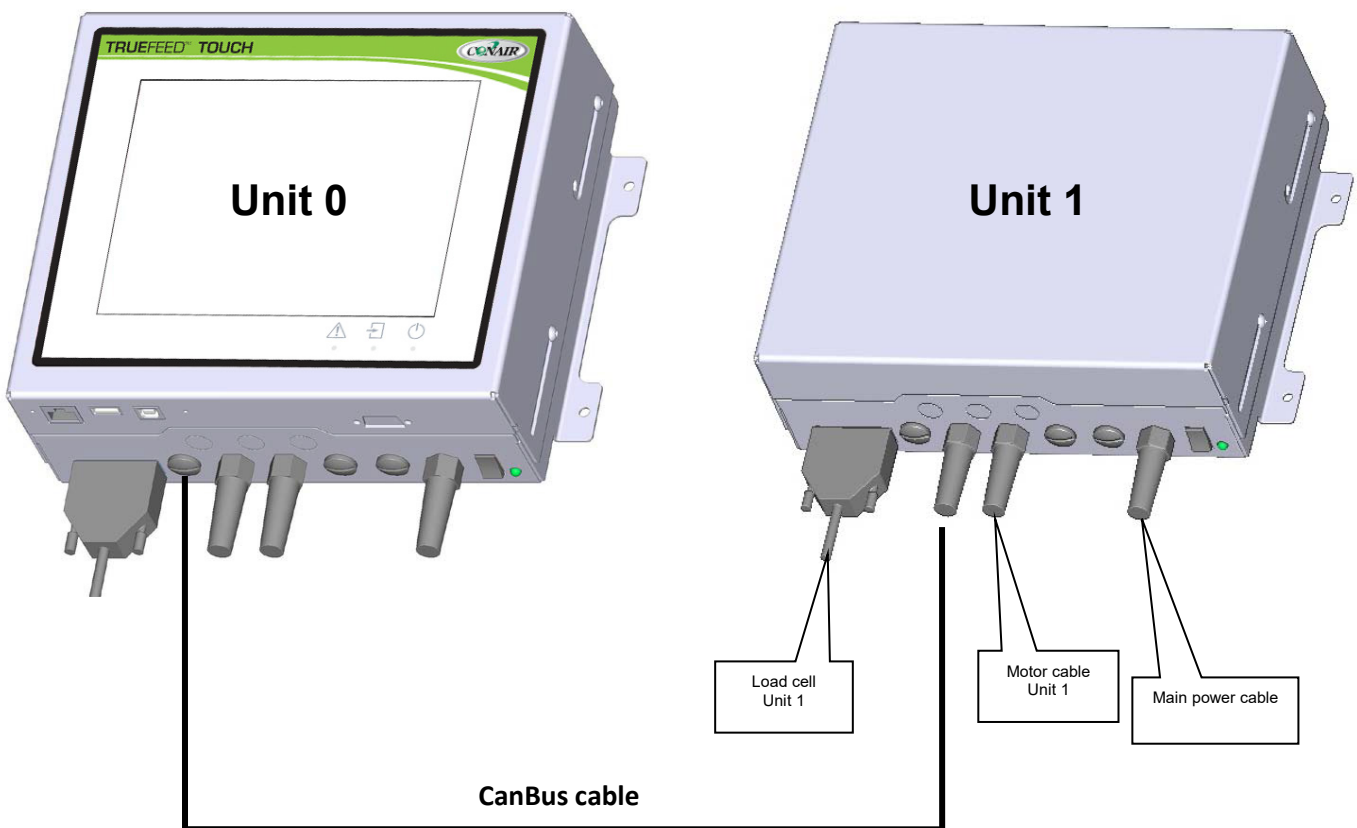

CanBus connection on Mainboards:

Nr.	Description	Wire
3	SHIELD	SHIELD
4	CAN-L	YELLOW
5	CAN-H	GREEN

Mainboard dipswitch settings:

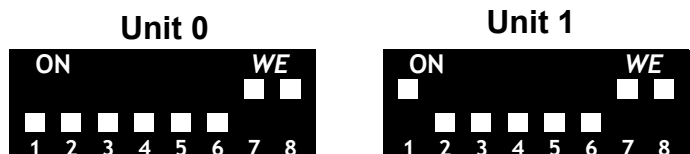

When in use, both units have to be switched on! Also when only 1 unit is used for dosing and other unit is on Standby.

## 8.2 Configuration Dual station

Make sure that both units have to be switched on before use. Otherwise a Warning message will appear with “Master/Slave connection failure”.

Configuring the unit for use with 2 units can be done in the advanced configuration menu. (Only available in Supervisor modus).

Home screen  → configuration menu  → Advanced configuration menu .

Scroll down until: **Number of Controllers.**

For a dual station, this should be set on 2. If necessary, adjust the number and reboot the controllers.

The home screen of a dual unit displays 2 dosing units. The production settings can be changed by pressing the required field.

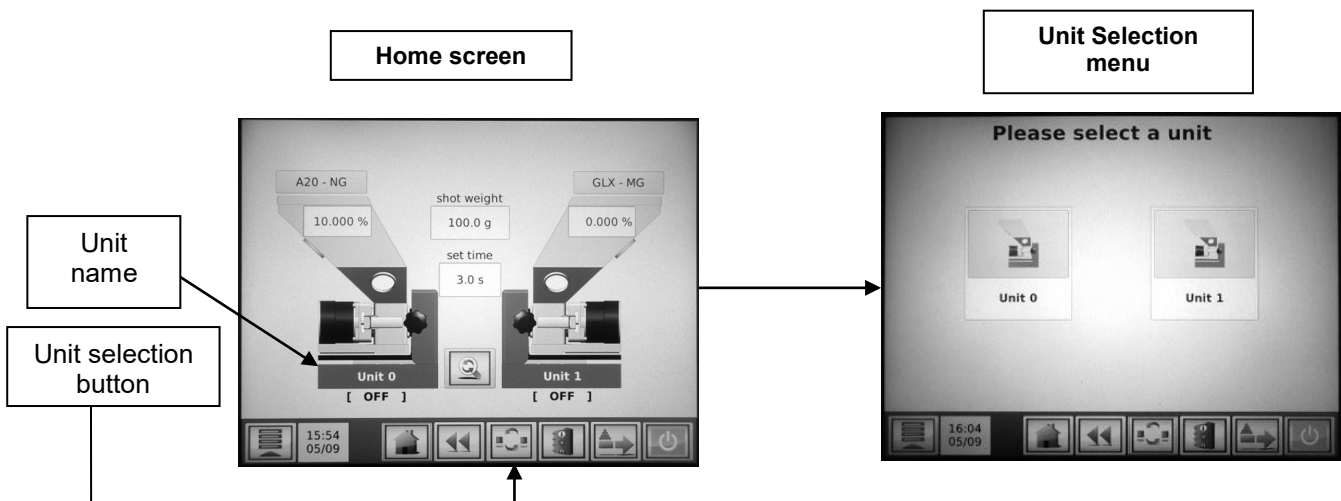

For changing a unit's configuration or making a material calibration the required unit has to be selected. Press the unit selection button, and select the unit.

In the device configuration menu, the Unit name is displayed. The name can be changed by pressing the name field.

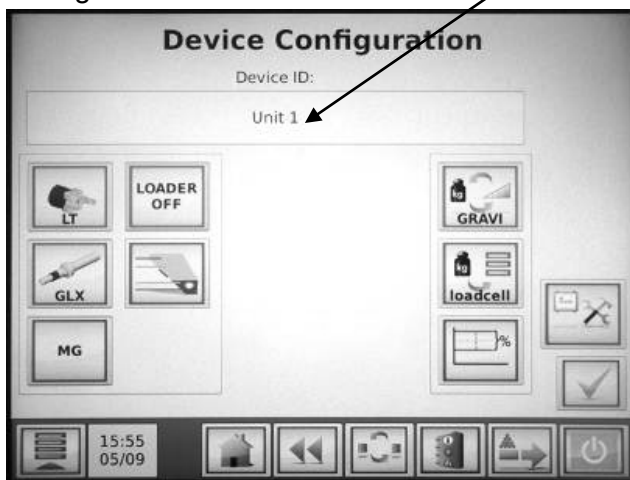

Please check chapter 7.3 for explanation of the configuration menu. When dosing with only 1 unit, enter 0% in the production settings for the other unit.

## 9. System performance

System performance can be characterized by the time it takes the unit to reach the desired set point, the accuracy of the set point and the regularity of the material output.

The algorithm is self-adjusting to the conditions and because the conditions vary, it cannot be predicted how long it will take the unit to adjust itself and reach a set point with certain accuracy.

The following variables influence system performance:

Material properties. Easy flowing, non-sticky and non-static material that comes in the form of small granules or powder can be dosed very accurate and regular. The accuracy and regularity of material output drops with increased granule size. However this is only a problem with extreme low outputs.

Periodical cleaning of the dosing cylinder and seals is necessary for proper operation.

Extreme vibrations and shocks influence system performance noticeably. Normally the system will be able to compensate for vibrations and shocks.

The TrueFeed algorithm needs a certain time to weigh material loss and adjust the RPM accordingly. This time depends largely on the set point and the above mentioned two variables. The system constantly adjusts itself to reach the best possible accuracy for current conditions. Over time it can reach accuracy within  $\pm 1\%$ .

Under "normal" circumstances the unit will be more accurate than 10% after the first adjustment of the RPM.

Before the unit makes its first RPM adjustment it might be running already very close to the desired set point because it uses a cylinder and material reference system to determine the first RPM setting. This accuracy however cannot be guaranteed because material properties can vary substantially from material to material.

With injection molding the shot to shot accuracy depends, besides the variables mentioned so far, on the shot time. If big and heavy granules have to be dosed in a very short time this will influence the shot accuracy and repeatability because one granule can make a difference of a few percent to the shot weight.

An unstable relay or tacho signal has a negative effect on the accuracy, repeatability and speed of the system because it will adjust to these parameter changes.

A long cycle time combined with low dosage per shot can result in a slow system.

### 9.1 Reset regulation

- Changing one parameter during production will cause the TrueFeed to adjust to the changes but it will not reset the regulation totally.
- Changing more production parameters during production within 10 seconds after each other will cause the TrueFeed regulation to reset. This is necessary for the system to adjust quickly to these big changes in the settings.
- Switching the power OFF and ON again will also cause the regulation to reset.
- Motor OFF and ON again will only cause the regulation to pause. The startup RPM will be the same as the last RPM before the stop.
- Changing one parameter with motor OFF causes total reset of the regulation.
- With auto start = ON (CONFIGURATION <menu>) the motor follows the last status (motor Standby or motor Stop status) and causes total reset of the regulation.

# 10. Trouble shooting

*Problem:* The balance does not come into specification or a maximum deviation alarm occurred.

*Possible causes:*

1. Check if all cables are connected correctly.
2. Check if the transport protection is removed from the load cell safety bolt.
3. Check if the hopper assembly is fixed tightly to the weighing platform and that the neckpiece is fixed tightly to the production machine.
4. Check if the dosing cylinder is tightly fixed to the motor shaft.
5. Excessive buildup of material on the dosing cylinder may have impact on proper dosing. To avoid this, be sure that the seals and dosing cylinder are clean.
6. Check if there is no tension on the cables connected to the weighing platform.
7. Use the weight check function with the reference weight to determine the correct function of the weighing system.
8. If the weight check gives the correct result, check if the material flow into the cylinder has been blocked.
9. Another cause may be an obstruction to the weighing system. Check if there is at least  $\approx 1$ mm space between all the pointed screws and the load cell frame or platform and that there is no material or dirt blocking the movement.
10. In case of water cooled neckpiece, check if there is material build up around the dosing cylinder and the water cooled pipe that can obstruct the free movement of the weighing system.
11. Check if the input signal is stable.
12. If none of the above causes the problem, recalibrate the system and try the weight check again.

*Problem:* The balance does come into specification but seems to be slow.

*Possible causes:*

1. Extreme vibrations and shocks to the system.
2. Extreme low Setpoint. See Chapter 8: SYSTEM PERFORMANCE
3. Check in case of use of an automatic hopper loader if the hoses are connected in the right way.

*Problem:* The input/start-signal is connected but the unit does not recognize this start signal.

*Possible causes:*

1. Check if the correct wires are connected for potential free contact, potential contact or tacho. Also check if the + and – side are connected correctly.  
[See wiring diagram in Appendix A.]
2. Automatic fuse is activated, this can for example happen when there was a short-circuit at the input connection. To deactivate the automatic fuse the controller needs to be switched OFF for a while and ON again, but first check and repair the short-circuit.

*Problem:* The hopper weight is not stable.

*Possible causes:*

1. Check if the weighing signal is not influenced by external circumstances, for example that the loadcell cable passes near to electromagnetic fields or electro motors.
2. Extreme vibrations and shocks to the system.
3. Check if there is no obstruction to the weighing frame.
4. Check in case of use of an automatic hopper loader if the hoses are connected in the right way.

# APPENDIX A: TrueFeed Wiring Diagram

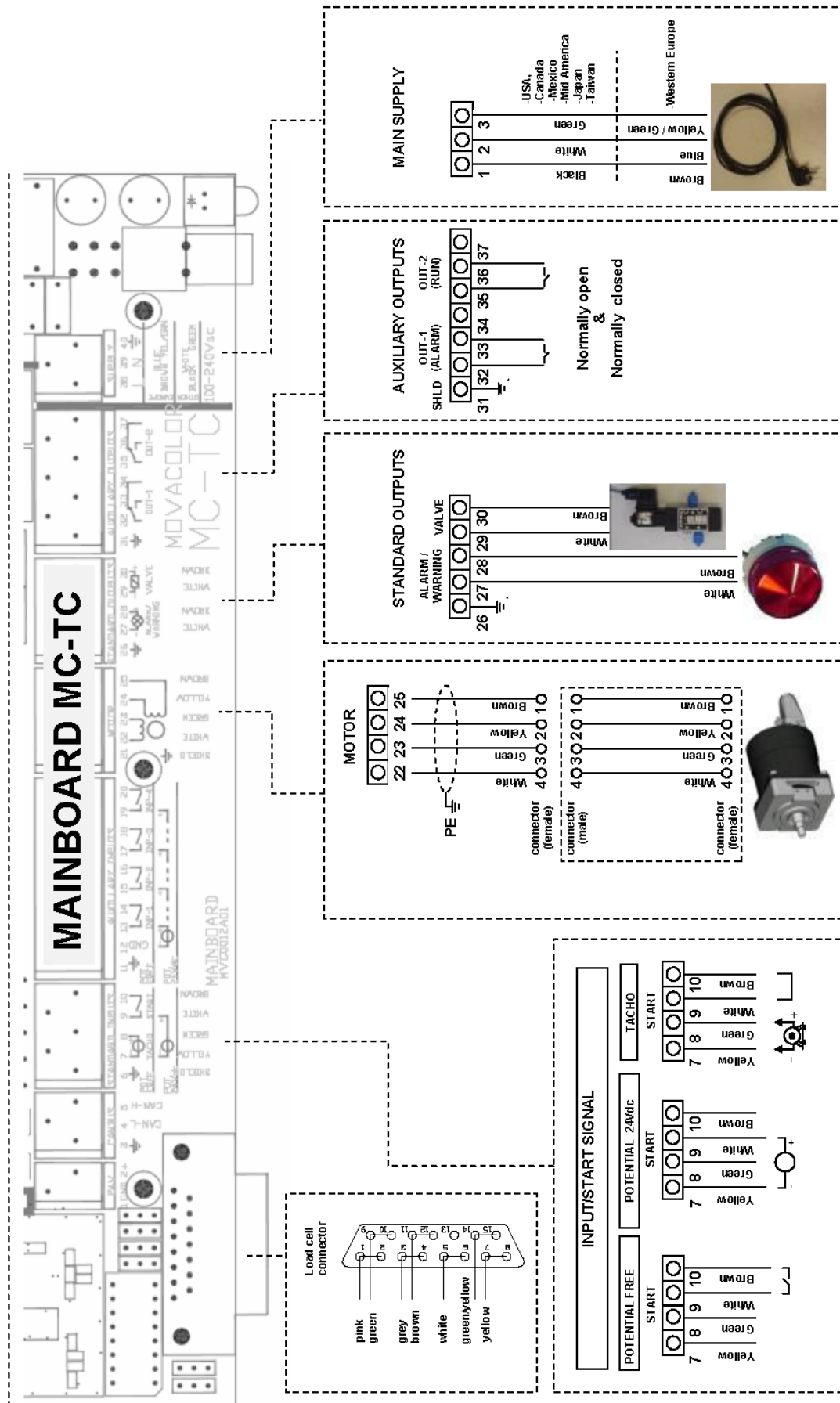

# APPENDIX B: TrueFeed Technical Specifications

## Controls:

Set and actual % setting for injection molding and extrusion  
Extrusion control by relay or tachometer  
Injection molding control  
Automatic metering time synchronization or by manual timer  
Manual speed and time setting  
Speed: Manual setting from 0.1 to 200 RPM max, in increments of 0.1 RPM.  
Time: Manual settings from 0.1 to 999 sec in increments of 0.1 sec.  
3 keyboard lock levels  
Integrated hopper loader controller

## Monitoring/System Information/External communication

External Communication: PC link using TCP/IP internet protocol; optional RS232 or 485 available  
Alarm: 2 user alarm levels

## Specifications/Standards & Directives/ Technical data:

Power supply: Operating power from 95 VAC to 250 VAC, 50 and 60 Hz  
by integrated automatic voltage selector  
Power consumption: 150 Watt maximum  
Stepper motor: (1.8degr/step) max 2A or 4A (high output) at 40 Volt.  
Operating Temperature: -20 to +70°C.  
Load cell and electronics: 20 bits A/D resolution with a full digital filtering

## Input signal(s):

Injection molding: Start/Stop trigger input, potential free or 24VDC\*  
Extrusion: Start/Stop trigger input, potential free or 24VDC\*  
Tacho input 0..30VDC

\* Note potential contact  
Guaranteed OFF: 0-8VDC  
Guaranteed ON: 18-30VDC

## Output(s):

-Stepper motor maximum output 2A or 4A (high output) at 40VDC  
-Solid state 24VDC/0.5 A output for valve hopper loader  
-Solid state 24VDC/0.5 A output for external warning  
-Relay for alarm level (max. 230Vac/30Vdc, 5A)  
-Relay for running contact (max. 230Vac/30Vdc, 5A)  
-Maximum total output power: 12 Watt (Valve output + alarm output)

## Standard Directives:

Protection class: IP-50  
According to CE standards:  
EN50081-2 (HF radiation industry)  
EN50082-2 (HF immunity industry)

## Safety

- In case of overload due to short-circuit or incorrect connection, the power supply automatically shuts down.
- Opt insulated start input for connection to production machine.

## Machine connection flange:

Standard flange NSt40-neckpiece with cleaning opening.  
Inlet/outlet ø50mm/□40mm, steel epoxy coated RAL 3002

## Loadframe:

- Balance frame: Steel, epoxy coated RAL 3002  
- Weighing frame: Aluminum, epoxy coated RAL 9005  
- Loadcell: Nominal Load: 20 kg.  
Temp. compensated  
Temp. range: -4 to +158°F {-20 to +70°C}  
Protection level: IP63 EN60529

## Optional parts

- 0.42 ft<sup>3</sup> {12 liter} hopper stainless steel.
- Flange type NSt90 with cleaning opening and inlet/outlet Ø50mm/□90mm, steel epoxy coated.
- Water-cooled flange BH (A) inlet/outlet 50mm/50mm stainless steel ANSI 304.
- Water-cooled flange PHA inlet/outlet 100mm/100mm
- Hopper loader type ME
- Hopper loader type MV
- Mixers
- External Alarm Flash light.
- External Alarm Siren.



# APPENDIX C: TrueFeed Decl. of Conformity

## DECLARATION OF CONFORMITY

(According to 2006/42/EG)

**Manufacturer's name** : The Conair Group  
**Address** : 200 West Kensinger Dr.  
Cranberry Twp., PA 16066

Declare under our sole responsibility that the product:

**Name** : Conair  
**Model** : TrueFeed  
**Year** : 20.....  
**Serial number** : .....

- Complies with the definition of the Machine Directive (2006/42/EG), and complies with the national legislation to enforcement of this directive;
- complies with the requirements of:
  - Low Voltage Directive (2006/95/EC)
  - EMC Directive (89/336/EEC)
- complies with the following standards or other normative documents:
  - NEN-EN 292-1/2 Safety of machinery part 1 + 2



## We're Here to Help

Conair has made the largest investment in customer support in the plastics industry. Our service experts are available to help with any problem you might have installing and operating your equipment. Your Conair sales representative also can help analyze the nature of your problem, assuring that it did not result from misapplication or improper use.

**Additional manuals and prints for your Conair equipment may be ordered through the Customer Service or Parts Department for a nominal fee.**

## How to Contact Customer Service

To contact Customer Service personnel, call:



**NOTE:** Normal operating hours are 8:00 am - 5:00 pm EST. After hours emergency service is available at the same phone number.

From outside the United States, call: 814-437-6861

You can commission Conair service personnel to provide on-site service by contacting the Customer Service Department. Standard rates include an on-site hourly rate, with a one-day minimum plus expenses.

## Before You Call...

**If you do have a problem, please complete the following checklist before calling Conair:**

- Make sure you have all model, control type from the serial tag, and parts list numbers for your particular equipment. Service personnel will need this information to assist you.
- Make sure power is supplied to the equipment.
- Make sure that all connectors and wires within and between control systems and related components have been installed correctly.
- Check the troubleshooting guide of this manual for a solution.
- Thoroughly examine the instruction manual(s) for associated equipment, especially controls. Each manual may have its own troubleshooting guide to help you.
- Check that the equipment has been operated as described in this manual.
- Check accompanying schematic drawings for information on special considerations.

## Equipment Guarantee

Conair guarantees the machinery and equipment on this order, for a period as defined in the quotation from date of shipment, against defects in material and workmanship under the normal use and service for which it was recommended (except for parts that are typically replaced after normal usage, such as filters, liner plates, etc.). Conair's guarantee is limited to replacing, at our option, the part or parts determined by us to be defective after examination. The customer assumes the cost of transportation of the part or parts to and from the factory.

## Performance Warranty

Conair warrants that this equipment will perform at or above the ratings stated in specific quotations covering the equipment or as detailed in engineering specifications, provided the equipment is applied, installed, operated and maintained in the recommended manner as outlined in our quotation or specifications.

Should performance not meet warranted levels, Conair at its discretion will exercise one of the following options:

- Inspect the equipment and perform alterations or adjustments to satisfy performance claims. (Charges for such inspections and corrections will be waived unless failure to meet warranty is due to misapplication, improper installation, poor maintenance practices or improper operation.)
- Replace the original equipment with other Conair equipment that will meet original performance claims at no extra cost to the customer.
- Refund the invoiced cost to the customer. Credit is subject to prior notice by the customer at which time a Return Goods Authorization Number (RGA) will be issued by Conair's Service Department. Returned equipment must be well crated and in proper operating condition, including all parts. Returns must be prepaid.

Purchaser must notify Conair in writing of any claim and provide a customer receipt and other evidence that a claim is being made.

## Warranty Limitations

**Except for the Equipment Guarantee and Performance Warranty stated above, Conair disclaims all other warranties with respect to the equipment, express or implied, arising by operation of law, course of dealing, usage of trade or otherwise, including but not limited to the implied warranties of merchantability and fitness for a particular purpose.**