

USER GUIDE  
UGD034-1216

# Carousel Plus Dryer

W Series Models 600 through 5000 with DC-2 Controls



Please record your equipment's model and serial number(s) and the date you received it in the spaces provided.

It's a good idea to record the model and serial number(s) of your equipment and the date you received it in the User Guide. Our service department uses this information, along with the manual number, to provide help for the specific equipment you installed.

Please keep this User Guide and all manuals, engineering prints and parts lists together for documentation of your equipment.

Date:

Manual Number: UGD034-1216

Serial Number(s):

Model Number(s):

See Screens 31 and 32 for Software Version

\*Display Firmware Version:

\*Display Menu Version:

\*Control Firmware Version:



\* **NOTE:** Displayed upon initialization, during power up, or on a data tag inside the door.

**DISCLAIMER:** Conair shall not be liable for errors contained in this User Guide or for incidental, consequential damages in connection with the furnishing, performance or use of this information. Conair makes no warranty of any kind with regard to this information, including, but not limited to the implied warranties of merchantability and fitness for a particular purpose.

# Table of Contents

## 1-1 Introduction

Purpose of the user guide . . . . .	1-2
How the guide is organized . . . . .	1-2
Using the Carousel Plus W Series as a central dryer . . . . .	1-3
Your responsibilities as a user . . . . .	1-3
ATTENTION: Read this so no one gets hurt . . . . .	1-4
How to use the lockout device . . . . .	1-6

## 2-1 Description

What is the Carousel Plus W Series Dryer? . . . . .	2-2
Typical applications . . . . .	2-2
How it works . . . . .	2-4
Specifications: Carousel Plus W Series Dehumidifying Dryers . . . . .	2-7
Carousel Plus W Series Dehumidifying Dryer options . . . . .	2-8

## 3-1 Installation

Unpacking the boxes . . . . .	3-2
Preparing for installation . . . . .	3-3
Positioning the dryer on the floor . . . . .	3-4
Removing the cable tie from the desiccant wheel (W600-1000) . . . . .	3-4
Installing the regeneration exhaust cover . . . . .	3-4
Installing the return air adapter . . . . .	3-5
Installing the return air inlet and air outlet adapters (W1600-5000) . . . . .	3-6
Installing the overhead process air duct (W3200-5000). . . . .	3-7
Connecting the main power . . . . .	3-8

Opening the dryer doors (W1600-5000) . . . . .	3-9
Checking for proper air flow . . . . .	3-9
Connecting the air hoses to a single hopper (W600-1000) . . . . .	3-12
Connecting the air hoses to a single hopper (W1600-5000) . . . . .	3-13
Connecting the air hoses to a ResinWorks . . . . .	3-14
Connecting the dryer to the hopper . . . . .	3-15
Connecting the dryer to ResinWorks . . . . .	3-15
Connecting air hose adapters . . . . .	3-16
Connecting the aftercooler and optional precooler (W600-1000) . . . . .	3-17
Connecting the intercooler (W1600-5000) . . . . .	3-18
Mounting a loader on the hopper . . . . .	3-19
Testing installation . . . . .	3-19
Using communications . . . . .	3-20

## 4-1 Operation

Carousel Plus W Series Dryer: control panel DC-2 . . . . .	4-2
Carousel Plus W Series Dryer control functions . . . . .	4-3
Control function flow charts . . . . .	4-3
How to navigate the menu tree . . . . .	4-3
Control function descriptions . . . . .	4-11
To start drying . . . . .	4-34
To stop drying . . . . .	4-35
How to use the supervisor's password . . . . .	4-36
Using the dewpoint monitor and dewpoint control . . . . .	4-38
Using the auto start timer . . . . .	4-39

## 5-1 Maintenance

Preventative maintenance checklist . . . . .	5-2
Checking the dewpoint . . . . .	5-3
Cleaning the hopper . . . . .	5-5
Cleaning the process filter. . . . .	5-6
Cleaning the regeneration filter . . . . .	5-8
Cleaning the aftercooler/intercooler coils . . . . .	5-9
Cleaning the precooler coils (W600-1000). . . . .	5-11
Cleaning the volatile trap on the demister . . . . .	5-11
Inspecting hoses and gaskets . . . . .	5-11

## 6-1 Troubleshooting

Before beginning . . . . .	6-2
A few words of caution . . . . .	6-3

### DIAGNOSTICS

How to identify the cause of a problem . . . . .	6-4
Shutdown alarms . . . . .	6-5
Passive alarms . . . . .	6-9
Dewpoint troubleshooting . . . . .	6-15
Poor material drying troubleshooting. . . . .	6-16

### REPAIR

Replacing fuses. . . . .	6-21
Checking heater solid state relays. . . . .	6-22
Checking or replacing temperature sensors . . . . .	6-23
Replacing the regeneration heater (W600-1000). . . . .	6-24
Replacing the regeneration heater (W1600-2400). . . . .	6-26
Replacing the regeneration heater (W3200-5000). . . . .	6-28
Replacing the desiccant wheel assembly (W600-1000). . . . .	6-30
Replacing the desiccant wheel motor (W600-1000) . . . . .	6-32
Replacing the desiccant wheel motor (W600-1000) . . . . .	6-33

## **A** Appendix

We're here to help .....	A-1
How to contact customer service .....	A-1
Before you call... ..	A-1
Equipment guarantee .....	A-2
Performance warranty .....	A-2
Warranty limitations .....	A-2

## **B** Appendix

Cleaning the precoolers coils (W600-1000) .....	B-1
---	-----

## **C** Appendix

Cleaning the volatile trap on the demister (W600-1000) .....	C-1
Cleaning the volatile trap on the demister (W1600-5000) .....	C-2

## Addendum

Communication protocols for common controls - DC-2
--

# Introduction

---

Purpose of the user guide. . . . . 1-2

How the guide is organized. . . . . 1-2

Using the Carousel Plus W Series

    as a central dryer . . . . . 1-3

Your responsibilities as a user. . . . . 1-3

ATTENTION:

    Read this so no one gets hurt . . . . . 1-4

How to use the lockout device. . . . . 1-6

# Purpose of the User Guide

This User Guide describes the Conair Carousel Plus W Series Dryer and explains step-by-step how to install, operate, maintain, and repair this equipment.

Before installing this product, please take a few moments to read the User Guide and review the diagrams and safety information in the instruction packet. You also should review manuals covering associated equipment in your system. This review won't take long, and it could save you valuable installation and operating time later.

# How the Guide is Organized

Symbols have been used to help organize the User Guide and call your attention to important information regarding safe installation and operation.



Symbols within triangles warn of conditions that could be hazardous to users or could damage equipment. Read and take precautions before proceeding.



Numbers indicate tasks or steps to be performed by the user.



A diamond indicates the equipment's response to an action performed by the user.



An open box marks items in a checklist.



A circle marks items in a list.



Indicates a tip. A tip is used to provide you with a suggestion that will help you with the maintenance and the operation of this equipment.



Indicates a note. A note is used to provide additional information about the steps you are following throughout the manual.

# Using the Carousel Plus W Series as a Central Dryer

The Conair Carousel Plus W600 - 5000 Series Dryers are factory configured to be used as central dryers only. Therefore, this manual incorporates the information necessary to use these dryers for central drying applications.

## Your Responsibility as a User

You must be familiar with all safety procedures concerning installation, operation and maintenance of this equipment. Responsible safety procedures include:

- Thorough review of this User Guide, paying particular attention to hazard warnings, appendices and related diagrams.
- Thorough review of the equipment itself, with careful attention to voltage sources, intended use and warning labels.
- Thorough review of instruction manuals for associated equipment.
- Step-by-step adherence to instructions outlined in this User Guide.

## ATTENTION:

### Read this so no one gets hurt

We design equipment with the user's safety in mind. You can avoid the potential hazards identified on this machine by following the procedures outlined below and elsewhere in the User Guide.



**WARNING: Improper installation, operation, or servicing may result in equipment damage or personal injury.**

This equipment should be installed, adjusted, and serviced by qualified technical personnel who are familiar with the construction, operation, and potential hazards of this type of machine.

All wiring, disconnects, and fuses should be installed by qualified electrical technicians in accordance with electrical codes in your region. Always maintain a safe ground. Do not operate the equipment at power levels other than what is specified on the machine serial tag and data plate.



**WARNING: Voltage hazard**

This equipment is powered by three-phase alternating current, as specified on the machine serial tag and data plate.

A properly sized conductive ground wire from the incoming power supply must be connected to the chassis ground terminal inside the electrical enclosure. Improper grounding can result in severe personal injury and erratic machine operation.

Always disconnect and lock out the incoming main power source before opening the electrical enclosure or performing non-standard operating procedures, such as routine maintenance. Only qualified personnel should perform troubleshooting procedures that require access to the electrical enclosure while power is on.

(continued)

## ATTENTION:

### Read this so no one gets hurt (continued)

We design equipment with the user's safety in mind. You can avoid the potential hazards identified on this machine by following the procedures outlined below and elsewhere in the User Guide.



#### **CAUTION: Hot Surfaces.**

Always protect yourself from hot surfaces inside the dryer and hopper. Also exercise caution around exterior surfaces that may become hot during use. These include the hopper door frame, the exterior of an uninsulated hopper, the return air hose and the dryer's process filter housing and moisture exhaust outlet.



#### **WARNING: Do not place aerosol, compressed gas or flammable materials on or near this equipment.**

The hot temperatures associated with the drying process may cause aerosols or other flammable materials placed on the dryer or hopper to explode.

## How to Use the Lockout Device

 **CAUTION:** Before performing maintenance or repairs on this product, you should disconnect and lockout electrical power sources to prevent injury from unexpected energization or start-up. A lockable device has been provided to isolate this product from potentially hazardous electricity.

Lockout is the preferred method of isolating machines or equipment from energy sources. Your Conair product is equipped with the lockout device pictured below. To use the lockout device:

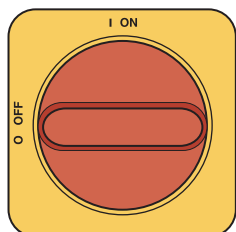



**1 Stop or turn off the equipment.**

**2 Isolate the equipment from the electric power.** Turn the rotary disconnect switch to the OFF, or “O” position.

**3 Secure the device with an assigned lock or tag.** Insert a lock or tag in the holes to prevent movement.

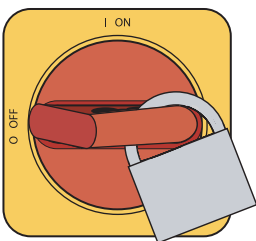
**4 The equipment is now locked out.**



 **WARNING:** Before removing lockout devices and returning switches to the ON position, make sure that all personnel are clear of the machine, tools have been removed, and all safety guards reinstalled.

To restore power to the dryer, turn the rotary disconnect back to the ON position:

**1 Remove the lock or tag.**

**2 Turn the rotary disconnect switch to the ON or “I” position.**

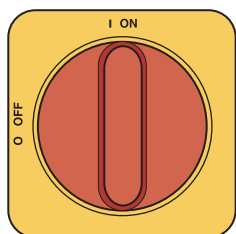

# Description

---

What is the Carousel Plus W Series Dryer? . . . 2-2

Typical applications . . . . . 2-2

How it works . . . . . 2-4

Specifications: Carousel Plus W Series

    Dehumidifying Dryers . . . . . 2-7

Carousel Plus W Series Dehumidifying

    Dryer options . . . . . 2-8

# What is the Carousel Plus W Series Dryer?

The Carousel Plus W Series Dehumidifying Dryer produces low-dewpoint air that removes moisture from hygroscopic plastics. The dryer pulls moist air from a drying hopper and circulates it through a dehumidifying desiccant wheel. The dryer then circulates the air through the material in the hopper.

The dryer's closed-loop design ensures a continuous supply of dehumidified air while preventing contamination from moisture in the plant.

## Typical Applications

- 1** Dryer on the floor, single hopper (with HTC Hopper Temperature Control package) on a floor stand.
- 2** Dryer on the floor, multiple hoppers in central configuration (ResinWorks) with separate heat source for each hopper.



**NOTE:** The W600 - 5000 provides no heat to the process air. A separate heat source is required at the hopper(s) inlet to heat the air to the desired drying temperature.

The Carousel Plus W Series Dryer can be used successfully in applications that require:

- A contamination-free drying environment.
- A constant flow of dehumidified air.

(continued)

# Typical Applications (continued)

Model	Drying Temperature Range
Low temperature (with precooler)*	100° - 150°F {38° - 66°C}
Standard	150° - 240°F {66° - 116°C}
High heat (with aftercooler/intercooler)*	150° - 375°F {66° - 191°C}
Low-high (aftercooler/intercooler & precooler)*	100° - 375°F {38° - 191°C}

\* See page 3-17, 3-18 and Appendix B

- Throughput rates of 600 to 5000 lbs {271 to 454 kg} per hour (some materials can be ran at a higher rate).
- Dewpoints of -40°F {-40°C}.

**Use the aftercooler/intercooler when:**

- You are drying at temperatures over 240°F {116°C}.
- Throughput rates are less than 50% of the dryer’s rated capacity.
- You are pre-drying material at temperatures over 150°F {66°C}
- The return air is 120°F {49°C} or above.



**NOTE:** The aftercooler/intercooler reduces the temperature of air returning from the drying hopper, improving the efficiency of the desiccant.

**Dryer Features**

- Dewpoint monitor/dewpoint control
- Audible and visual alarm
- DeviceNet communications (Alternate communications are available)



**NOTE:** Temperature setback is only available in conjunction with the Hopper Temperature Controller (HTC) or ResinWorks system.



**NOTE:** Carousel Plus W Series 600-1000 Dryers use an aftercooler located before the the process blower. Carousel Plus W Series 1600-5000 uses an intercooler located after the process blower.

# How It Works

## ■ The Process (Drying) Cycle (w600 - 1000)

Process air from the hopper is pulled into the dryer, through the process filter and then into the process blower inlet. Air exits the process blower and then enters the aftercooler, then passes through the desiccant wheel, where moisture is removed. The air exits the dryer and passes through the precooler (if installed), then into the process heat source (HTC or CGT Gas Unit). After the air exits the process heat source it then goes into the hopper inlet, then to the spreader cone, which evenly distributes the air through the material.

## ■ The Process (Drying) Cycle (w1600 - 5000)

Process air from the hopper is pulled into the dryer, through the process filter and then into the process blower inlet. Air exits the process blower and then enters the intercooler, then passes through the desiccant wheel, where moisture is removed. The air exits the dryer and passes through the precooler (if installed), then into the process heat source (HTC or CGT Gas Unit). After the air exits the process heat source it then goes into the hopper inlet through internal piping, then to the spreader cone, which evenly distributes the air through the material.

## ■ The Regeneration Cycle

The regeneration blower pulls air through the regeneration filter into the dryer's regeneration heater. The air is heated to 350°F {177°C} before it is pushed into the "wet" section of the desiccant wheel. The hot air purges moisture from the desiccant. The moist air is blown out the moisture exhaust at the top of the dryer.

## □ The Cooling Cycle (All models except W2400 and W5000)

Regenerated desiccant must be cooled before it rotates back into the process cycle. The process blower pushes the process air through the desiccant wheel. A small amount of the process air is diverted through a small section of the desiccant wheel to cool the air. The cooling air then returns back to the process air stream at the start of the process cycle.

# How It Works (continued)

(W600 - 1600 and 3200)

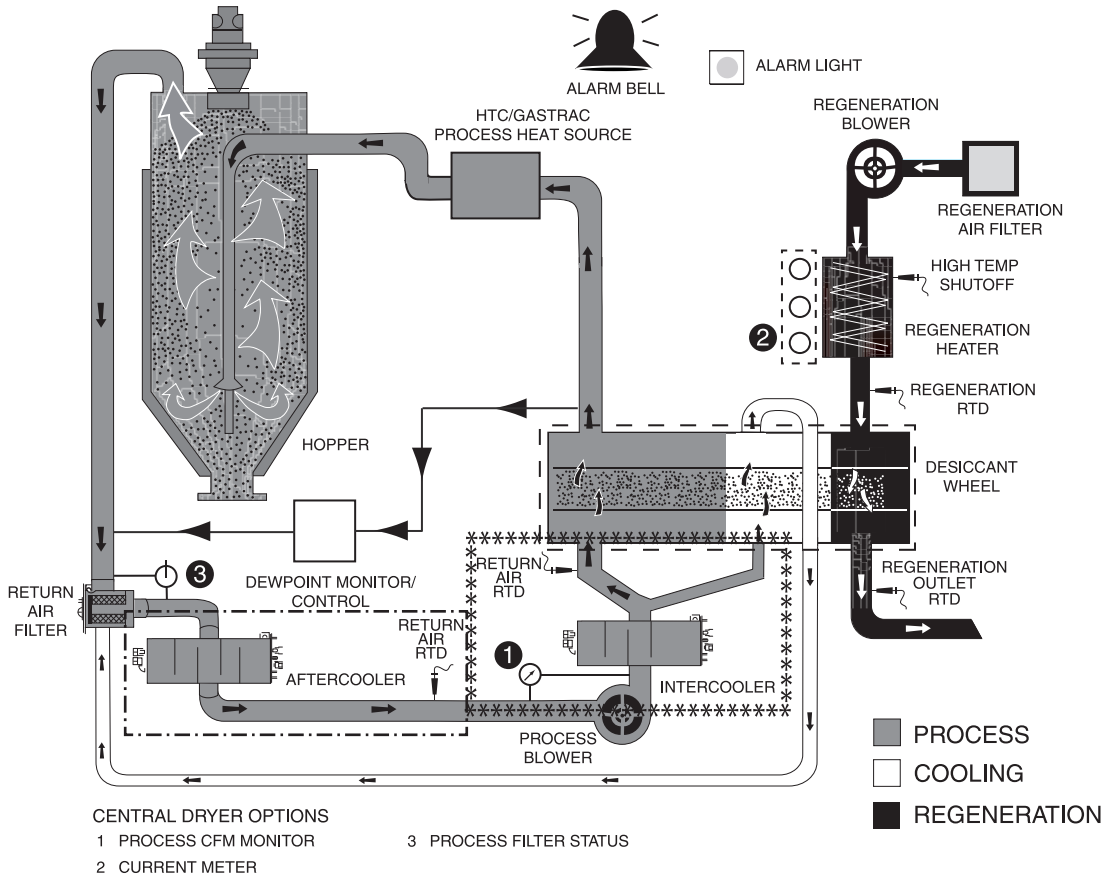

W-series 600-1000  
aftercooler location.

\*\*\*\*\*  
\* W-series 1600-5000  
\* intercooler location only.  
\*\*\*\*\*

**NOTE:** Earlier W1600-5000 dryers will have their intercoolers in the W600-1000 location.

**NOTE:** Carousel Plus W Series 600-1000 Dryers use an aftercooler located before the the process blower. Carousel Plus W Series 1600-5000 dryers use an intercooler located after the process blower.

# How It Works (continued)

(W2400 and W5000)

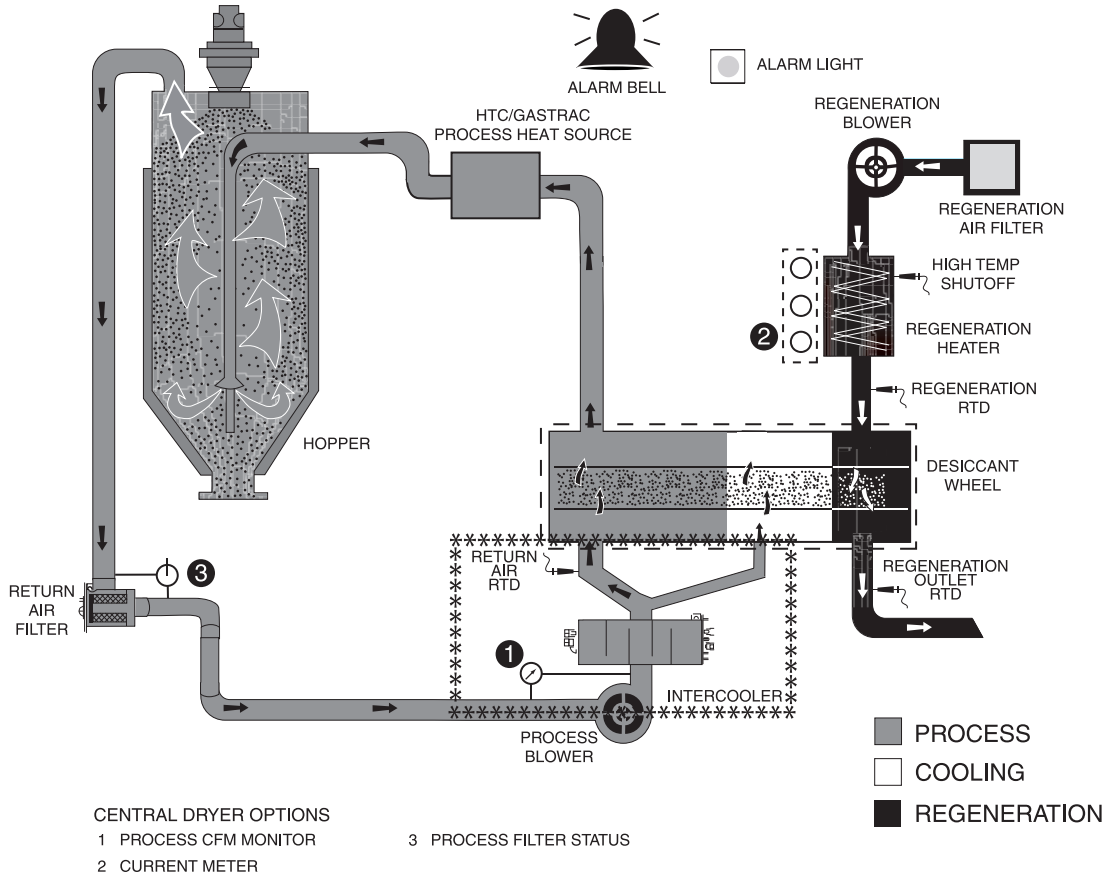

## Power Purge

W 2400 and 5000 models have a Power Purge (cooling fan) feature integral to the desiccant wheel assembly.

**NOTE:** Carousel Plus W Series 600-1000 Dryers use an aftercooler located before the the process blower. Carousel Plus W Series 1600-5000 dryers use an intercooler located after the process blower.

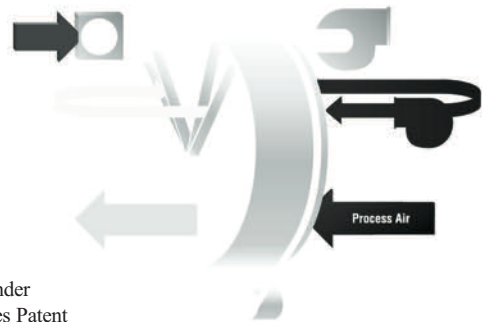

Protected under United States Patent No. 7,101,414 and other US and Foreign Patents Pending.

# Specifications: Carousel Plus W Series Dehumidifying Dryers

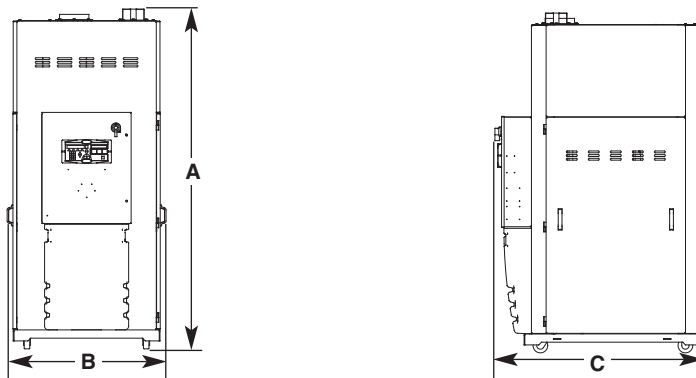

MODELS	W600*	W800*	W1000*	W1600*††	W2400*††	W3200*††	W5000*††
<b>Performance characteristics</b> (with full hopper)							
Drying temperature	All models 100 - 375°F {38 - 191°C} with options						
Dewpoint	All models -40°F {-40°C}						
<b>Dimensions</b> inches {cm}							
A - Height	92.6 {235.2}			95.5 {242.6}		102.8 {261.1}	
B - Width	43.3 {109.9}			48.3 {122.7}		48.9 {124.2}	
C - Depth	57.6 {146.3}			86.2 {218.9}		112.0 {284.5}	
Outlet/inlet hose diameter	8 {20.3}			12 {30.5}		12 {30.5}	
<b>Approximate weight</b> lbs {kg}							
Installed	1300 {590}	1300 {590}	1400 {636}	1600 {726}	1600 {726}	2000 {907}	2000 {907}
Shipping	1495 {678}	1515 {687}	1515 {687}	2100 {953}	2620 {1188}	3385 {1535}	3385 {1535}
<b>Voltage</b> - Total amps							
400 V/3 phase/50 Hz†	37.2	37.2	37.5	64.7	73.7	122.3	128.0
460 V/3 phase/60 Hz	32.0	32.0	32.2	56.3	63.1	106.6	111.0
575 V/3 phase/60 Hz	25.6	25.6	25.7	45.0	50.5	85.3	89.1
<b>Water requirements</b> {for aftercooler/intercooler or optional precooler}§							
Recommended temperature**	45° - 85°F {7- 29}						
Water flow gal./min. {liters/min.}	6-25 {22.7-94.6}		12-40 {45.4-151.4}			15-50 {56.8-189.3}	
Water connections NPT	1 1/2 in. NPT						

## SPECIFICATION NOTES:

\* Dryers W600-W5000 are central dryers and do not have process heaters. Hopper Temperature Controllers (HTC's) or ResinWorks systems are used at the hopper for heating the process air. See the Hopper Temperature Controller (HTC) specification sheet for additional information.

† Dryers running at 50 Hz will have 17% less airflow, and a 17% reduction in material throughput.

‡ Total kW listed at a regeneration temperature of 350°F {177°C}.

§ When drying below 150 °F {66°C} a precooler is required. When drying above 180°F {82°C} an aftercooler/intercooler and insulated drying hose is required.

\*\* Temperatures above or below the recommended levels may affect dryer performance. Tower, chiller or municipal water sources can be used.

†† Models W1600-5000 do not have casters.

Specifications may change without notice. Consult a Conair representative for the most current information.

# Carousel Plus W Series Dehumidifying Dryer Options

- **Volatile trap** (only in conjunction with aftercooler/intercooler) - The volatile trap is recommended if drying materials that produce volatile that condense into a waxy or oily residue and/or if the material contains excessive fines.
- **Precooler** - The precooler reduces the temperature of air after the desiccant wheel and before the process heater, which enables the dryer to control temperatures at low setpoints, (100° - 150°F {38° - 66°C})
- **Filter check** - The filter check sensor will activate a passive alarm when the process filter is clogged or needs to be replaced.
- **CFM monitor** - The CFM monitor measures the cubic feet per minute of air flow across the inlet/outlet of the process blower.
- **Communications** - Allows the dryer to be networked to industrial control systems. DeviceNet is standard. Modbus, SPI and Ethernet are available.
- **Heater current monitor** - The heater current monitor measures the total amperage across both the process and regeneration heaters and the pre-determined power consumption values for the blowers and the control.



**NOTE:** Temperature setback is only available in conjunction with the Hopper Temperature Controller (HTC) or the ResinWorks system.



**NOTE:** The Drying Monitor 2 (DM-II) is for use with single hopper applications, it is not applicable on ResinWorks systems.

# Installation

---

Unpacking the boxes . . . . .	3-2
Preparing for installation . . . . .	3-3
Positioning the dryer on the floor. . . . .	3-4
Removing the cable tie from the desiccant wheel (W600-1000) . . . . .	3-4
Installing the regeneration exhaust cover . . .	3-4
Installing the return air adapter. . . . .	3-5
Installing the return air inlet and air outlet adapters (W1600-5000) . . . . .	3-6
Installing the overhead process air duct (W3200-5000). . . . .	3-7
Connecting the main power. . . . .	3-8
Opening the dryer doors (W1600-5000). . . . .	3-9
Checking for proper air flow . . . . .	3-9
Connecting the air hoses to a single hopper (W600-1000). . . . .	3-12
Connecting the air hoses to a single hopper (W1600-5000). . . . .	3-13
Connecting the air hoses to a ResinWorks . .	3-14
Connecting the dryer to the hopper . . . . .	3-15
Connecting the dryer to ResinWorks . . . . .	3-15
Connecting air hose adapters . . . . .	3-16
Connecting the aftercooler and optional precooler (W600-1000) . . . . .	3-17
Connecting the intercooler and optional precooler (W1600-5000) . . . . .	3-18
Mounting a loader on the hopper . . . . .	3-19
Testing the installation. . . . .	3-19
Using communications . . . . .	3-20

# Unpacking the Boxes

The Carousel Plus W Series Dryer comes in one to four boxes, depending on the model and options ordered. The boxes could include (depending on the options selected):

- Carousel Plus W Series Dryer
- Delivery air hose
- Return air hose
- User Guide

**1 Carefully remove the dryer and components** from their shipping containers. Note that the dryer is secured to its shipping container with metal bands that pass through the bottom of the dryer frame.

**2 Unbolt any additional items secured to the shipping pallet**, such as the regeneration exhaust cover and return air adapter. (Carousel Plus W Series 1600-2400 Dryers will have a dry air delivery adapter. Carousel Plus W Series 3200-5000 Dryers will have a dry air delivery adapter and an overhead process air duct.)

**3 Remove all packing material**, protective paper, tape, and plastic.

**4 Cut and remove the desiccant wheel tie** securing the wheel assembly. (W600-1000) 

**5 Carefully inspect all components** to make sure no damage occurred during shipping, and that you have all the necessary hardware.

(continued)

## Unpacking the Boxes (continued)

**6 Take a moment to record serial numbers** and electrical power specifications in the blanks provided on the back of the User Guide's title page. The information will be helpful if you ever need service or parts.

**7 You are now ready to begin installation.**

Follow the preparation steps on the next page, then choose one of the two mounting options:

- Dryer on the floor, single hopper (with HTC Hopper Temperature Control package) on a floor stand.
- Dryer on the floor, multiple hoppers in central configuration (ResinWorks) with separate heat source for each hopper.

 **NOTE:** The W600 - 5000 provides no heat to the process air. A separate heat source is required at the hopper(s) inlet to heat the air to the desired drying temperature.

## Preparing for Installation

The Carousel Plus W Series Dryer is easy to install if you plan the location and prepare the mounting area properly.

**1 Make sure the mounting area provides:**

- ❑ **A grounded power source supplying the voltage and correct current** for your dryer model. Check the dryer's serial tag (on the control box) for the correct amps, voltage, phase, and cycles. Field wiring should be completed by a qualified personnel to the planned location for the dryer. All electrical wiring should comply with your region's electrical codes.
- ❑ **A source of water, when using the aftercooler/intercooler and/or pre-cooler.** The W Dryer's aftercooler/intercooler and/or pre-cooler require tower, city, or chiller water at temperatures of 45° to 85°F {7° to 29°C}. Refer to the Specifications Sheet (page 2-7) for flow rate for your unit. Piping should be ran to the planned dryer location. Use flexible hose to connect the water pipes to the aftercooler/intercooler and/or optional pre-cooler.
- ❑ **Minimum clearance for safe operation and maintenance.** You should maintain 24 in. {61 cm} clearance on all sides of the dryer.

 **TIP:** If you plan to use vacuum or compressed air loaders to fill the hopper, install conveying lines to the drying hopper location.

 **NOTE:** The aftercooler/inter-cooler reduces the temperature of air returning from the drying hopper, improving the efficiency of the desiccant.

## Positioning the Dryer on the Floor

- 1** Lift the dryer from the shipping container using a fork truck.
- 2** Position the dryer on the floor near the hopper or ResinWorks sled. Make sure the location allows for the connection of all hoses, keeping hose lengths as short as possible.

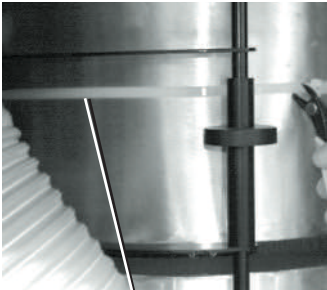

Desiccant Cable Tie

## Removing the Cable Tie from the Desiccant Wheel (W600-1000 models)

- 1** Open the dryer side panels and remove the cable tie securing the desiccant wheel, if it was not done while unpacking the dryer.

## Installing the Regeneration Exhaust Cover

The Carousel Plus W Series Dryer's regeneration exhaust cover must be installed.

To install the regeneration exhaust cover:

- 1** Remove the exhaust cover that is attached to the dryer's shipping pallet.
- 2** Locate the bolt pattern at the top of the dryer, on top of the regeneration exhaust outlet.
- 3** Position the regeneration exhaust cover on top of the regeneration exhaust outlet, aligning both bolt patterns.
- 4** Secure the regeneration exhaust cover with supplied hardware, using an appropriately sized wrench.

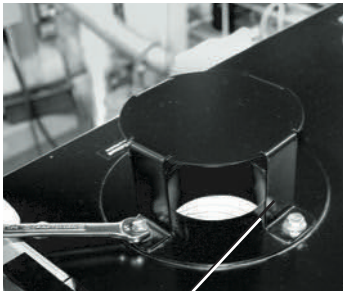

Regeneration Exhaust Cover

# Installing the Return Air Adapter

The Carousel Plus W Series Dryer's return air adapter must be installed.

To install the return air adapter:

- 1** Remove the return air adapter that is attached to the dryer's shipping pallet.
- 2** Locate the bolt pattern on the top of the dryer, on top of the return air inlet.
- 3** Position the return air adapter on top of the return air inlet, aligning both bolt patterns.
- 4** Secure the return air adapter with supplied hardware, using an appropriately sized wrench.

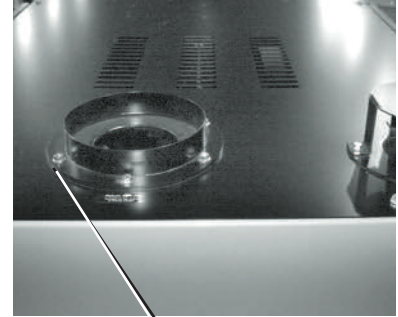

Return Air  
Inlet Adapter

# Installing the Return Air Inlet and Air Outlet Adapters (W1600 - 5000)

The Carousel Plus W Series Dryer's return air inlet and air outlet adapters will be removed when the dryer is shipped

**To install the return air inlet and air outlet adapters:**

- 1 Remove the return air inlet and air outlet adapters that are attached to the dryer's shipping pallet.**
- 2 Locate the bolt patterns on the top of the dryer, on top of the return air inlet and air out outlet.**
- 3 Position the return air adapter on top of the return air inlet, aligning both bolt patterns.**
- 4 Secure the return air adapter with supplied hardware, using appropriately sized wrench.**
- 5 Position the air inlet adapter on top of the inlet air inlet, aligning both bolt patterns.**
- 6 Secure the air inlet adapter with supplied hardware, using an appropriately sized wrench.**

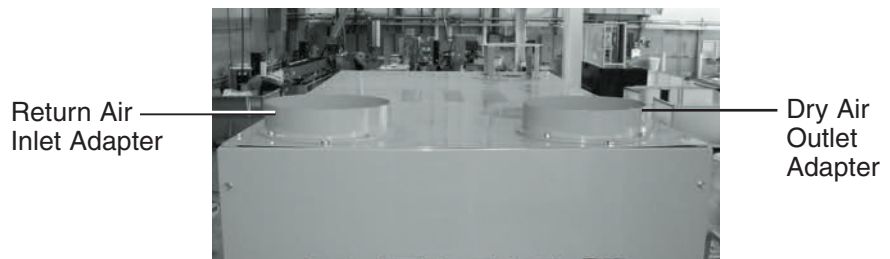

# Installing the Overhead Process Air Duct (W3200 - 5000)

The Carousel Plus W Series Dryer's overhead process air duct will be removed when the dryer is shipped.

To install the overhead process air duct:

- 1 Remove the overhead process air duct that is attached to the dryer's shipping pallet.** The piping will be shipped as one unit with included gaskets (2).
- 2 Locate the bolt patterns on the top of the dryer,** over top of the overhead process air duct inlet and outlet.
- 3 Position the overhead process air duct on top of the overhead process air duct inlet and outlet making sure to place supplied gaskets between the overhead process air duct and the inlet and outlet of the dryer,** align all bolt patterns.
- 4 Secure the piping with supplied hardware,** using an appropriately sized wrench.

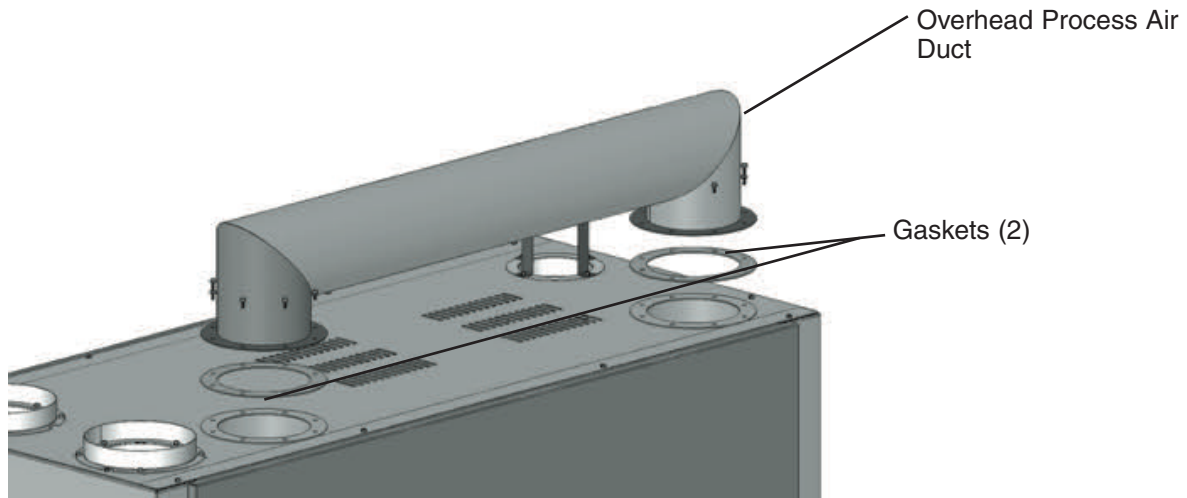

## Connecting the Main Power



**CAUTION:** Always disconnect and lock out the main power sources before making electrical connections. Electrical connections should be made only by qualified personnel.

- 1 Open the dryer's electrical enclosure.** Turn the disconnect dial on the dryer door to the Off or "O" position. Lock out the main power (see Page 1-6 for complete lock out information). Turn the captive screw, and swing the door open.

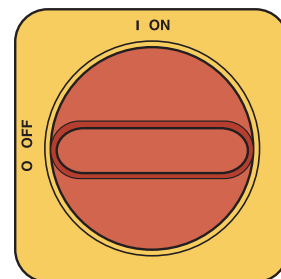

- 2 Insert the main power wire** through the knock-out in the side of the enclosure or the rear of the dryer. (the dryer's electrical wire connection location was a factory option and may be connected through the front or the rear of the dryer.) Secure the wire with an appropriate strain relief.

**IMPORTANT:** Always refer to the wiring diagrams that came with your dryer before making electrical connections.

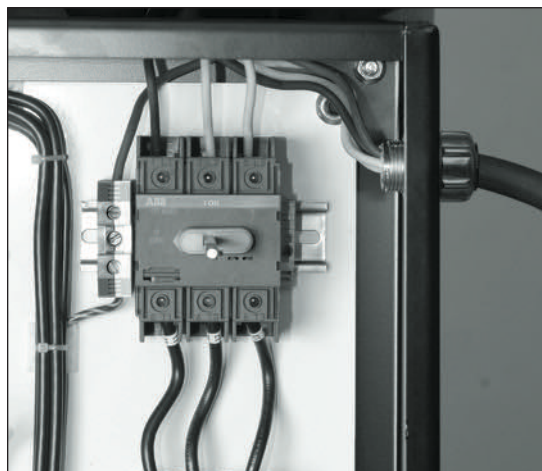

- 3 Connect the power wires** to the three terminals at the top of the power disconnect holder.
- 4 Connect the ground wire** to the ground lug as shown in the photo.

# Opening the Dryer Doors

(W1600 - 5000)

Carousel Plus W Series 1600-5000 Dryers designed after August 2007 will have locking side panel door bolts.

To unlock the side panel door bolts:

- 1 Rotate the two (2) locking door bolts on the dryer door counterclockwise** with a regular screw driver.
- 2 Close the dryer doors and rotate the two (2) locking door bolts clockwise** to resecure the dryer doors.

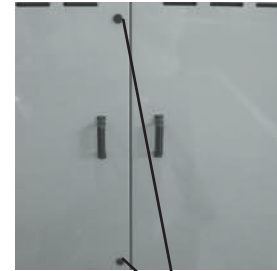

Dryer Door Locking Bolts (2)  
(W1600-5000)

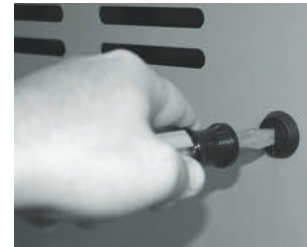

# Checking for Proper Air Flow

This procedure is needed on W600-5000 models if the phase detection option was not ordered with the dryer.

**IMPORTANT:** This procedure must be performed before the dryer's air hoses are connected to the hopper or before loading material into the hopper.

 **CAUTION:** If the air flow direction is incorrect due to improper phase connection, material from the hopper can be pulled back into the dryer, causing permanent damage to this equipment.

**1 Turn on the main power to the dryer.** Make sure the dryer's disconnect dial is in the ON position. This powers up the control and the display lights will illuminate.

**2 Press the START button**  **then the STOP button.** 



(continued)

## Checking for Proper Air Flow (continued)



**NOTE:** Models W600-1000 dryer aftercooler and dry air delivery configuration shown. Location on larger models are different. Refer to the labeling on your dryer. See Installation section entitled, Installing the Return/Delivery Air Adapters, for proper air line connections.

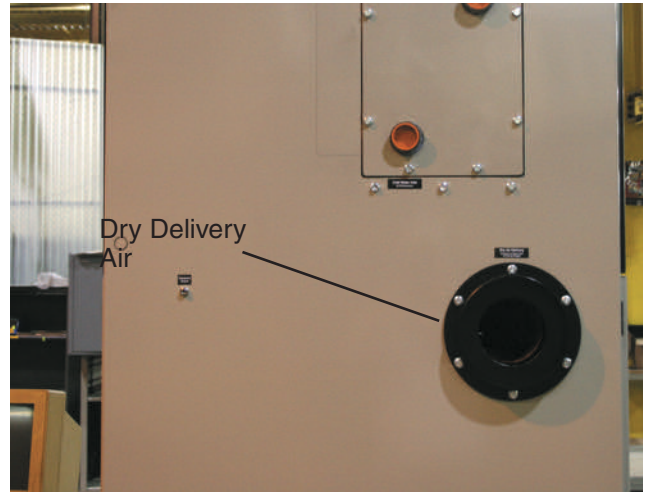

- 3** Visually verify the blower motor is moving in the correct direction indicated by the arrow on the blower housing. The W series 600-5000 dryers are equipped with centrifugal process blowers.





Direction  
Indication  
Arrow

(continued)

## Checking for Proper Air Flow (continued)

**4** If air flow is incorrect disconnect power, follow proper lockout procedures and swap any 2 of the 3 main power wires.

 **WARNING:** All wiring, disconnects, and fuses should be installed by qualified electrical technicians in accordance with electrical codes in your region. Always maintain a safe ground. Do not operate the equipment at power levels other than what is specified on the the machine serial tag and data plate.

 If the air flow is reversed, the process blower is turning in the wrong direction. Turn off and lock out the main power source. Open the electrical enclosure and reverse any two leads connecting the main power supply to the dryer.

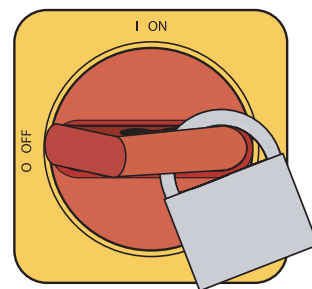
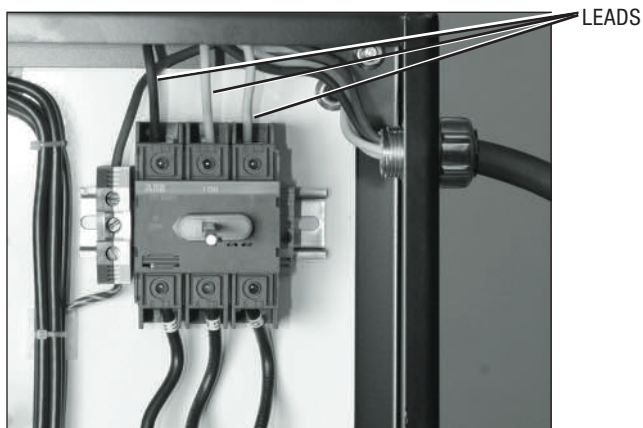



 **WARNING:** All wiring, disconnects, and fuses should be installed by qualified electrical technicians in accordance with electrical codes in your region. Always maintain a safe ground. Do not operate the equipment at power levels other than what is specified on the the machine serial tag and data plate.

# Connecting the Air Hoses to a Single Hopper (W600 - 1000)

Using the two flexible hoses provided, connect the inlet of the HTC and outlet of the drying hopper to the dryer. Make sure the dryer is located as close as possible to the hopper (approximately 10 ft {3.05 m}).

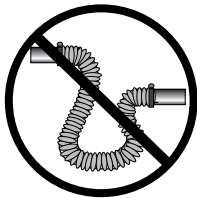
 **NOTE:** Models W600-1000 dryer aftercooler and dry air delivery configuration shown. Location on larger models are different. Refer to the labeling on your dryer.



 **NOTE:** Do not allow the flexible hoses to kink or crimp.

**1 Attach one hose from the return air inlet, located on top of the dryer, to the outlet of the hopper.**

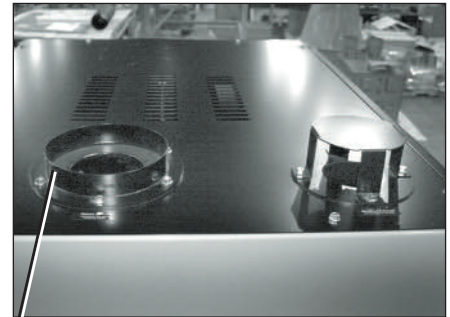

Return Air Inlet Adapter

**2 Attach one hose from the delivery air outlet to the inlet of the HTC.**

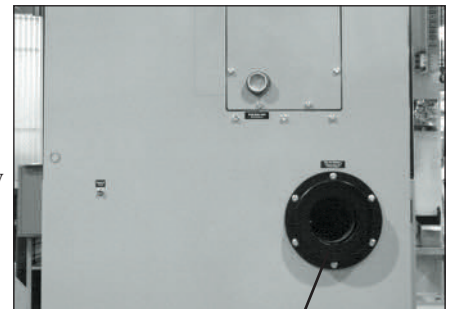

Dry Delivery Air

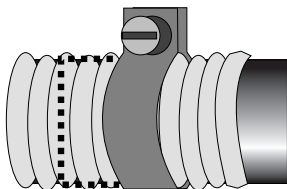

**3 Secure hoses with clamps.** The hose clamp should be secured at least 1/4 in. {0.64 cm} from the end of the inlet or outlet tube.

# Connecting the Air Hoses to a Single Hopper (W1600 - 5000)

Using the two flexible hoses provided, connect the inlet of the HTC and outlet of the drying hopper to the dryer. Make sure the dryer is located as close as possible to the hopper (10 ft {3.05 m} of hose supplied).

- 1 Attach one hose from the return air inlet, located on top of the dryer, to the outlet of the hopper.**

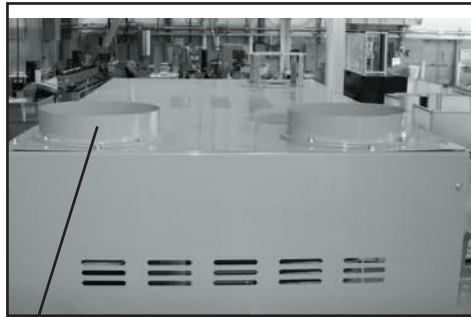

Return Air Inlet

- 2 Attach one hose from the delivery air outlet, located on top of the dryer, to the inlet of the HTC.**

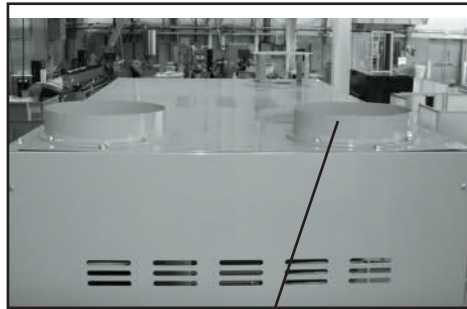

Delivery Air Outlet

- 3 Secure hoses with clamps.** The hose clamp should be secured at least 1/4 in. {0.64 cm} from the end of the inlet or outlet tube.

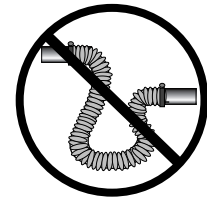
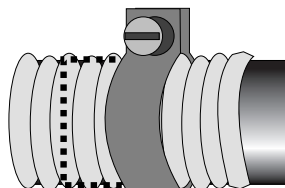

**NOTE:** Do not allow the flexible hoses to kink or crimp.

# Connecting the Air Hoses to a ResinWorks

Using the two flexible hoses provided, connect the delivery air and return air manifolds of the ResinWorks to the dryer. Make sure the dryer is located as close as possible to the sleds (10 ft {3.05 m} of hose supplied).

**1 Attach one hose from the return air inlet** of the dryer to the return air manifold of the ResinWorks.

**2 Attach one hose from the delivery air outlet** of the dryer to the delivery air manifold of the ResinWorks.

**3 Secure hoses with clamps.** The hose clamp should be secured at least 1/4 in. {0.64 cm} from the end of the inlet or outlet tube.

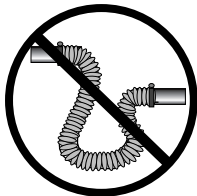

**NOTE:** Do not allow the flexible hoses to kink or crimp.

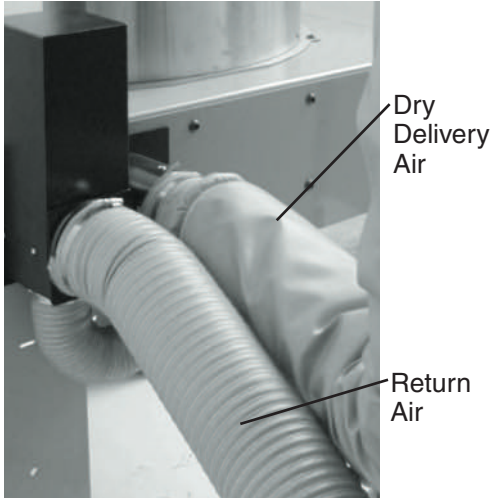
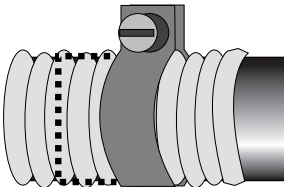

Insulated hose shown not standard.

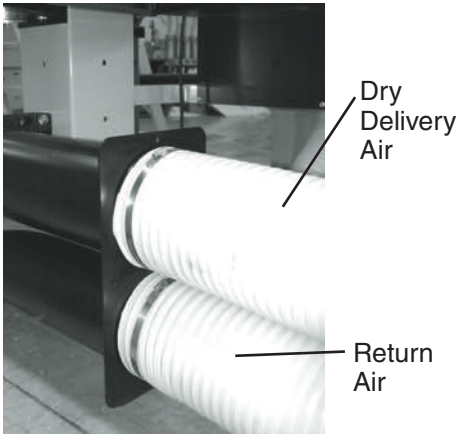

## Connecting the Dryer to the Hopper

If your dryer hose connection and your hopper HTC hose connection are not the same size, you will need a hose adapter. Contact Conair Parts 1 800-458-1960.

### Connecting the Dryer to



**NOTE:** Because the W600 - 5000 models require a separate heat source for the delivery air, all references to this heat source will be identified as “HTC” (Hopper Temperature Controller). When using this dryer with an HTC, reference the User Guide supplied with the HTC for installation instructions.

## ResinWorks

If your dryer hose connection and the connection on your ResinWorks sled are not the same size, you will need to use a hose adapter. Contact Conair Parts 1 800-458-1960.



**NOTE:** Because the W600-5000 models require a separate heat source for the delivery air, all references to this heat source will be identified as ResinWorks. When using this dryer with a ResinWorks sled reference the User Guide supplied with the ResinWorks sled for installation instructions.

# Connecting Air Hose Adapters

Depending on the hopper you purchased you may need to install an air hose adapter to connect the hopper to your dryer.

To connect the air hose adapter:

- 1** Place a high temperature gasket approximately half way down from the end of the dry air delivery outlet.

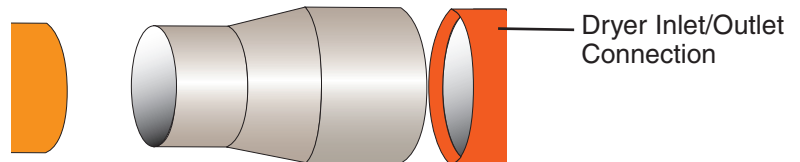

- 2** Place hose adapter inside high temperature gasket flush to the dryer outlet, secure with pressure clamp.

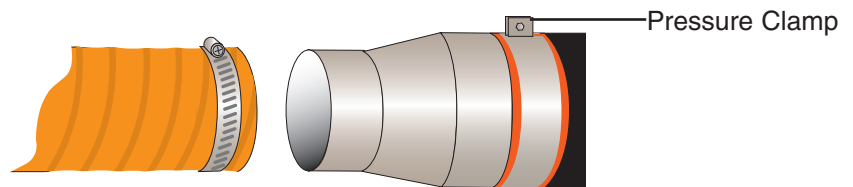

- 3** Attach the hopper inlet hose over the adapter, secure with clamp.

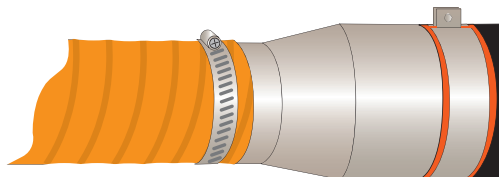

# Connecting the Aftercooler and Optional Precooler (W600 - 1000)

The aftercooler and/or optional precooler require a source of city, tower, or chiller water and a discharge or return line. You can use water at temperatures of 45 to 85°F {7 to 29°C}. But the water flow should be at least 3 gal/min {11.4 liters/min}.



Aftercooler Inlet

## 1 Connect the water supply line to the aftercooler or precooler inlet.

If a manual shut off valve is used, it should be mounted on the inlet line.



Aftercooler Outlet

## 2 Connect the water discharge or return line with the pressure relief valve to the aftercooler or precooler outlet. Use the bracket supplied to secure the pressure relief valve to the back of the dryer.

**IMPORTANT:** Turn the water off when the dryer is not in use to prevent condensation.

➤ **TIP:** Make the water supply and discharge / return connections with flexible hoses at least 24 in. (61 cm) long. This allows you to easily remove the aftercooler assembly for cleaning.

➤ **TIP:** If an optional flow control is also being installed with the aftercooler, the manual shut off valve should be installed on the inlet line for the flow control.

✎ **NOTE:** Models W600-1000 dryer aftercooler and dry air delivery configuration shown. Location on larger models are different. Refer to the labeling on your dryer.

# Connecting the Intercooler and Optional Precooler (W1600 - 5000)

➡ **TIP:** Make the water supply and discharge / return connections with flexible hoses at least 24 in. (61 cm) long. This allows you to easily remove the intercooler assembly for cleaning.

➡ **TIP:** If an optional flow control is also being installed with the intercooler, the manual shut off valve should be installed on the inlet line for the flow control.

The intercooler and/or optional precooler require a source of city, tower, or chiller water and a discharge or return line. You can use water at temperatures of 45 to 85°F {7 to 29°C}. But the water flow should be at least 3 gal/min {11.4 liters/min}.

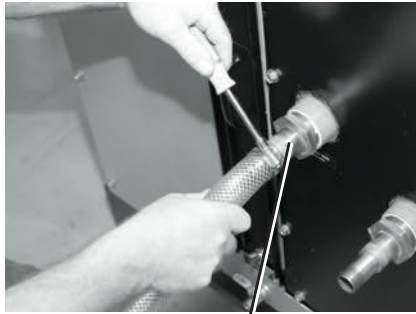

Intercooler Inlet

**1** Connect the water supply line to the intercooler or precooler inlet.

If a manual shut off valve is used, it should be mounted on the inlet line.



Intercooler Outlet

**2** Connect the water discharge or return line with the pressure relief valve to the intercooler or precooler outlet. Use the bracket supplied to secure the pressure relief valve to the back of the dryer.

**IMPORTANT:** Turn the water off when the dryer is not in use to prevent condensation.

# Mounting a Loader on the Hopper

If you have a Conair loader or vacuum receiver, you can use the flange and mounting clips provided on the top of the hopper. Refer to the manuals that came with your receiver or loader for detailed installation instructions.

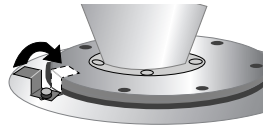

# Testing the Installation

You have completed the installation. Now it's time to make sure everything works.

- 1 Make sure there is no material in the hopper.** If you have mounted a loader or vacuum receiver on the hopper, disconnect the material inlet hose at the source.
- 2 Turn on the main power to the dryer.** Make sure the dryer's disconnect dial is in the ON position. This powers up the control and the display lights will illuminate.

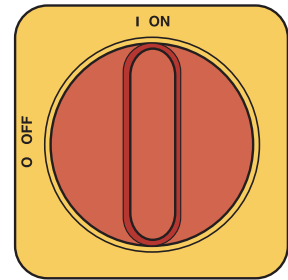

Installation  
3

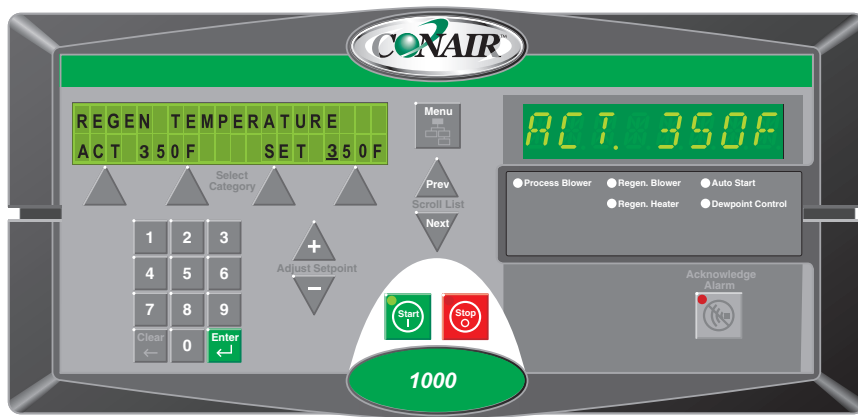

- 3 Press the START button.**



If everything is installed correctly:

- The green light on the start button will illuminate.
- The regeneration and process blowers turn on and LEDs will illuminate.
- The regeneration heater turns on and LED will illuminate.
- The desiccant wheel starts turning

# Testing the Installation

## 4 Press the STOP button.



If everything is installed correctly:

- The blowers will continue running as needed to cool the heaters. (until regeneration heaters are less than 150°F {66°C})

## 5 The test is over. If the dryer performed the normal operating sequences as outlined, you can load the hopper and begin operation. If it did not, refer to the *Troubleshooting section* of the User Guide.

# Using Communications

The DeviceNet cable feature is a standard feature on W600-5000 dryers with DC-2 controls. It allows the dryer to be connected your communications network.

If the communications feature will NOT be used for your application, simply coil the cable to keep it out of the way. If the communications feature IS to be used for your application, please refer to the documentation supplied in the Communication Addendum of this manual.



To use the optional SPI, Modbus, Ethernet or standard DeviceNet communications see the Addendum for hardware installation and configuration.



SPI Connection



DeviceNet Connection



Ethernet Connection

# Operation

---

Carousel Plus W Series Dryer:	
control panel DC-2 . . . . .	4-2
Carousel Plus W Series Dryer	
control functions . . . . .	4-3
Control function flow charts . . . . .	4-3
How to navigate the menu tree . . . . .	4-3
Control function descriptions. . . . .	4-11
To start drying . . . . .	4-34
To stop drying. . . . .	4-35
How to use the supervisor's password. . . . .	4-36
Using the dewpoint monitor and dewpoint	
control . . . . .	4-38
Using the auto start timer. . . . .	4-39

# Carousel Plus W Series Dryer: Control Panel DC-2

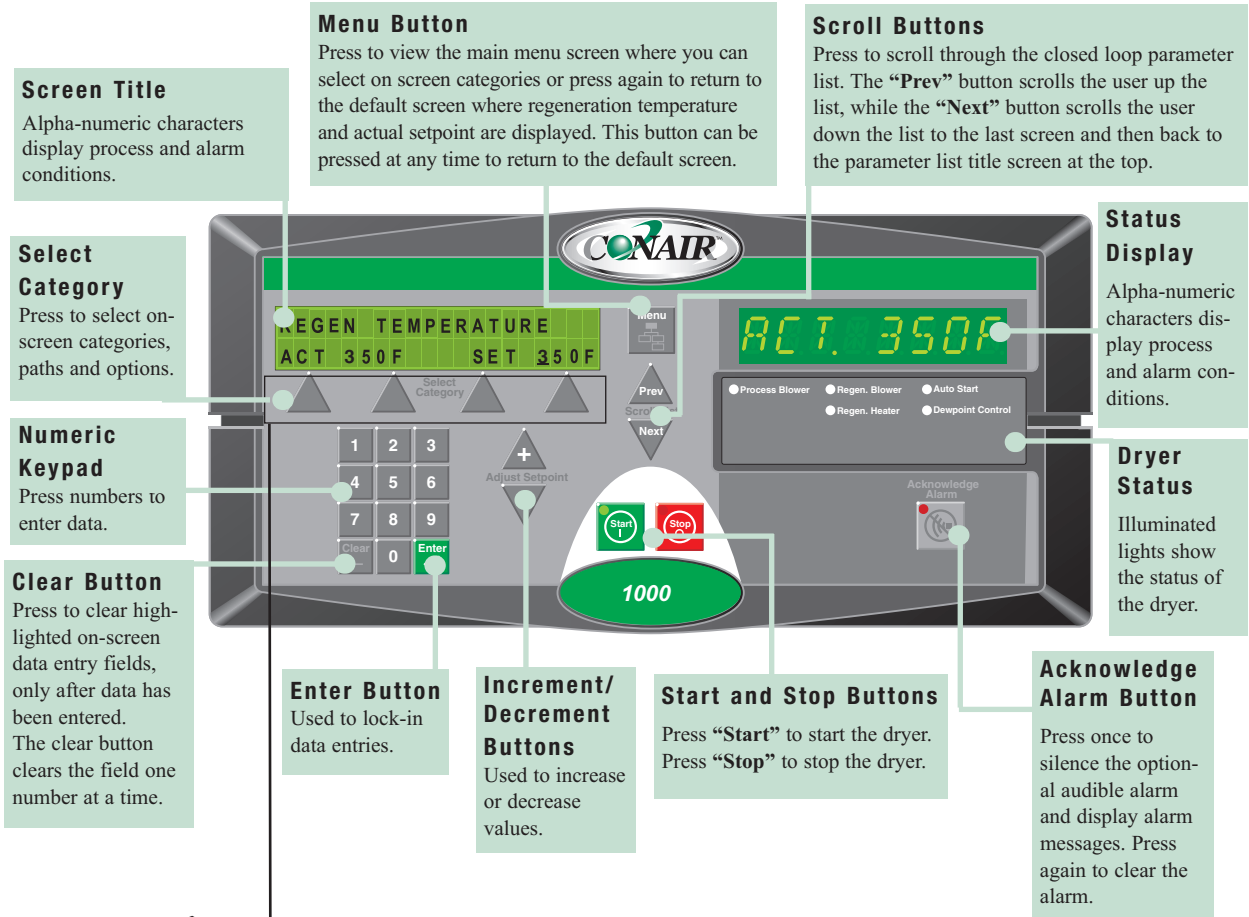

**NOTE:** When changing a setpoint use the Select Category Key directly below the value to be changed. Once pressed the value will blink, then use the keypads or (+) (-) adjustment setpoints to enter the new value. Then press enter for the new value to be recognized.

# Carousel Plus W Series Dryer Control Functions

Dryer functions are values that you can set or monitor in the Screen Title and Status Display windows. Press the Menu button then the Scroll List “Next” or “Prev” buttons until the function you want to set or monitor appears in the Screen Title window.

## Control Function Flow Charts

The charts beginning on page 4-4 provide a quick summary of the control functions. For an explanation of each control function, see Control Function Descriptions (page 4-11). The screen numbers correspond with the numbers beside each block in the flow chart.





**NOTE:** In the flow charts of the display screens that follow this page, the grey shaded screens denote optional functions. If the options were not purchased with the dryer, those screens will not appear. Most options can be purchased and installed in the field.

## How to Navigate the Menu Tree

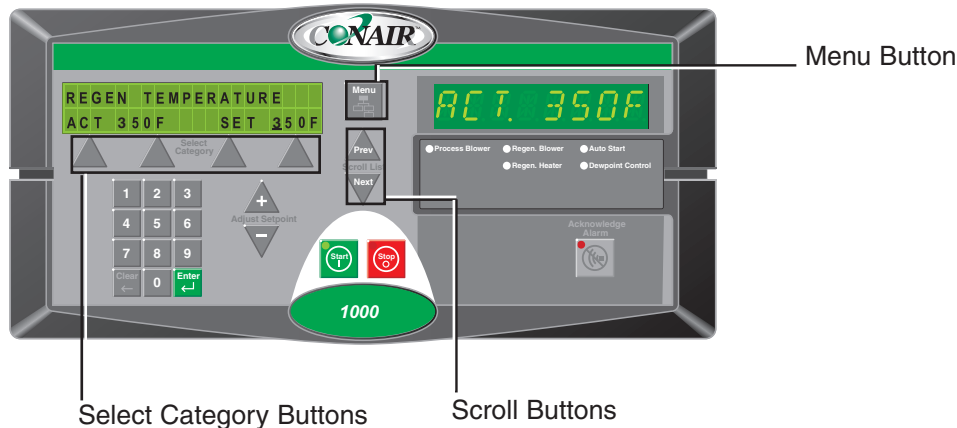
To scroll through main menu, use scroll buttons (“Next”, “Previous”). Push “Menu” to access Dryer Main Menu . To access the Status, Setup, Diagnostic and Password screens, use the select category buttons under the digital read-out and then the scroll buttons (“Next”, “Previous”) to scroll through the parameter lists.

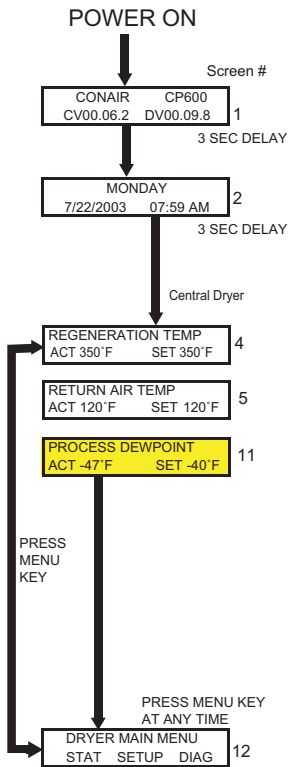



 **NOTE:** In the event new control boards are installed, screens showing Process and MDC may be present. The boards will need to be configured for a central dryer. If this is not done, alarms will occur.

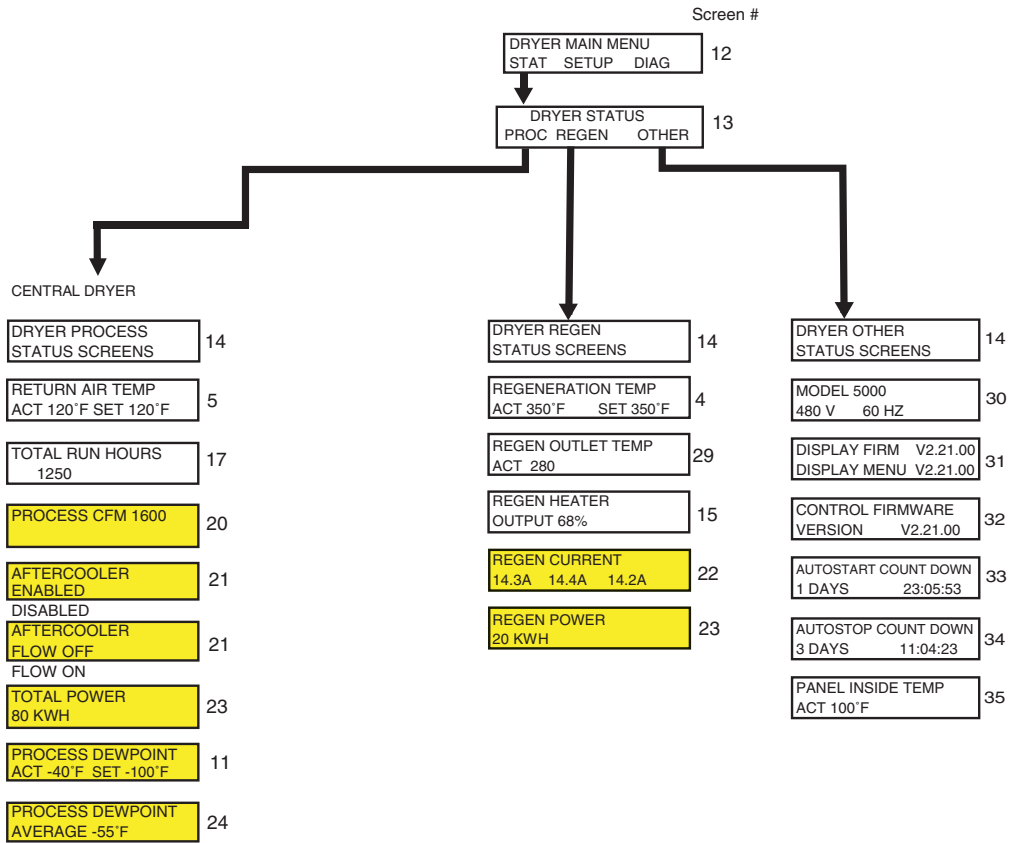

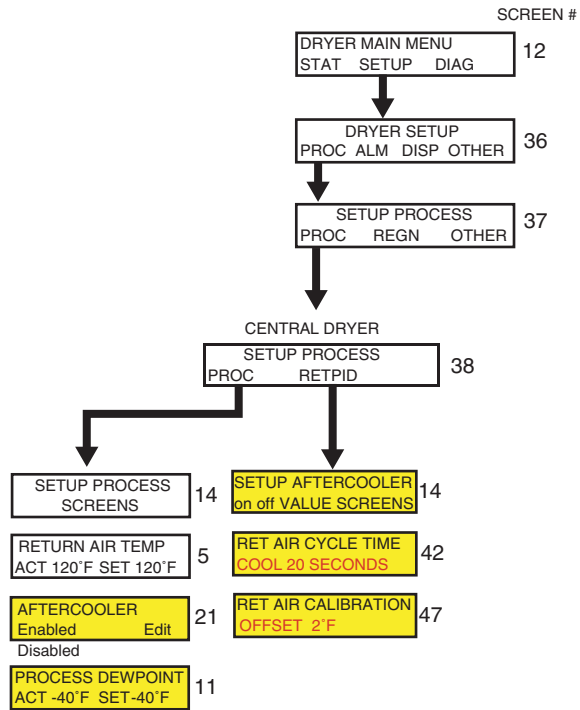

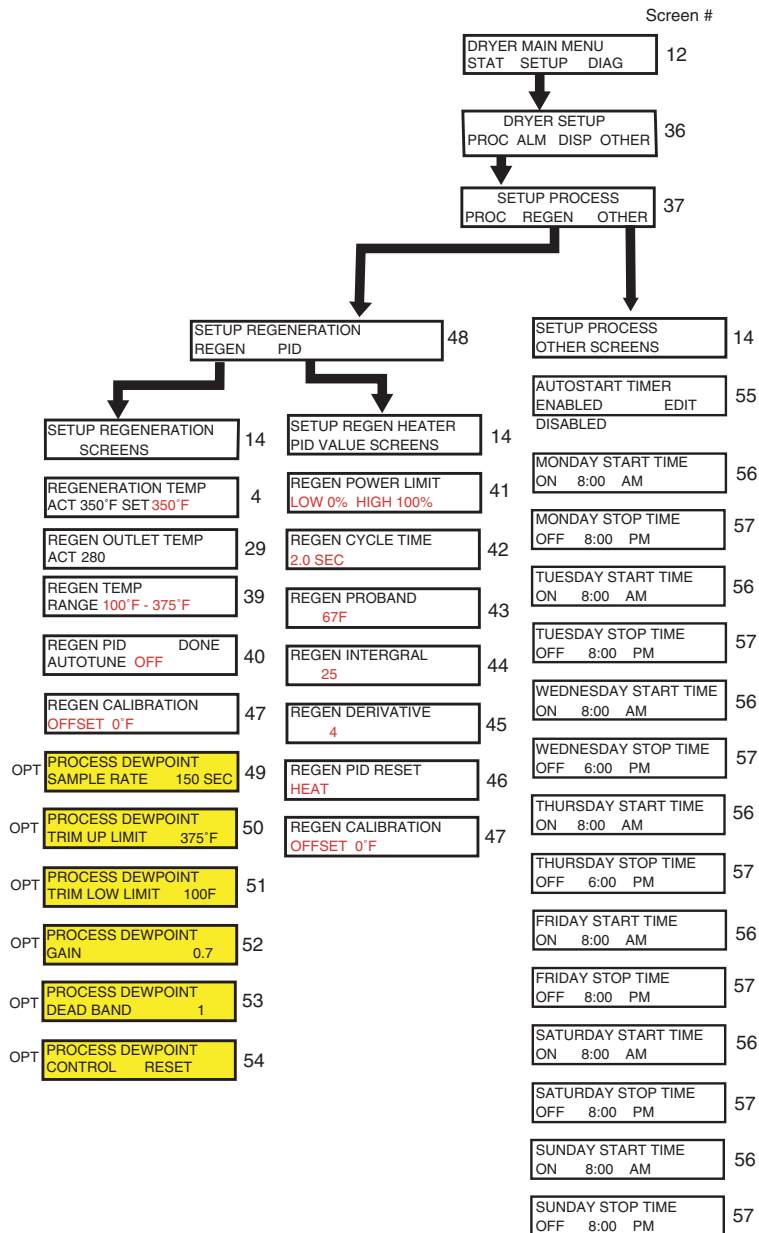

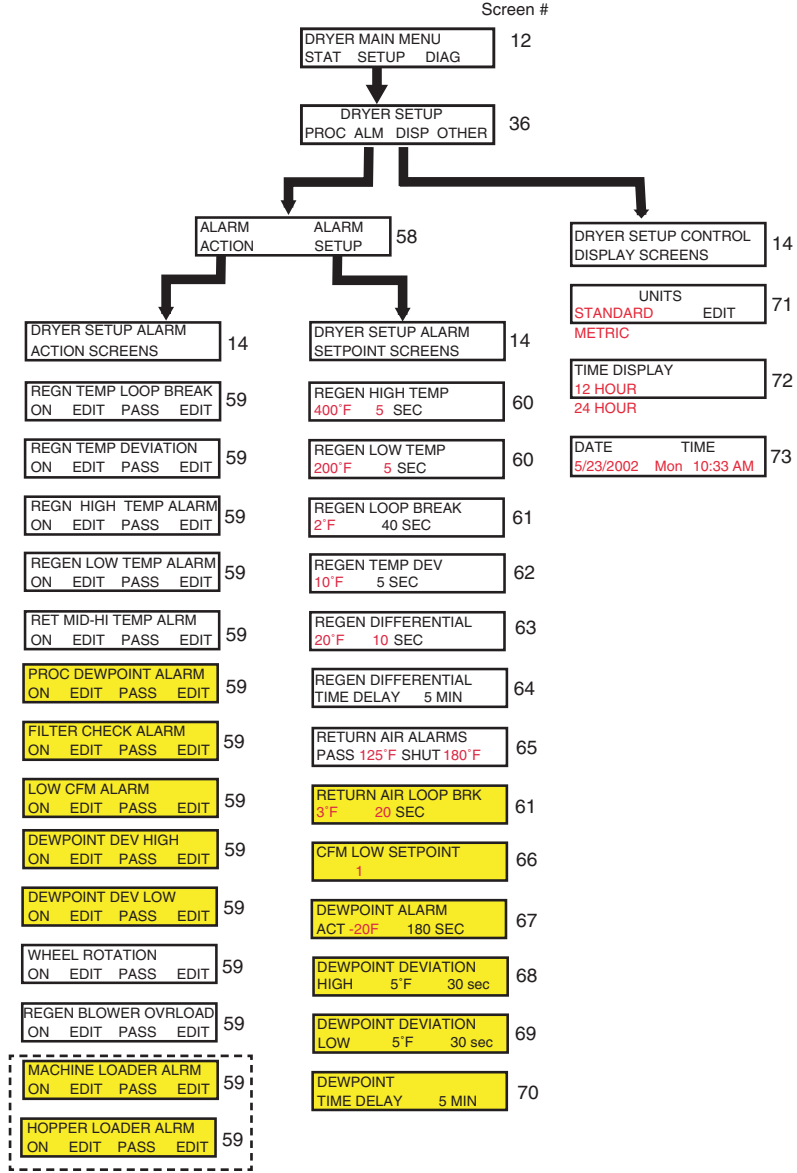

These screens are visible but not functional.

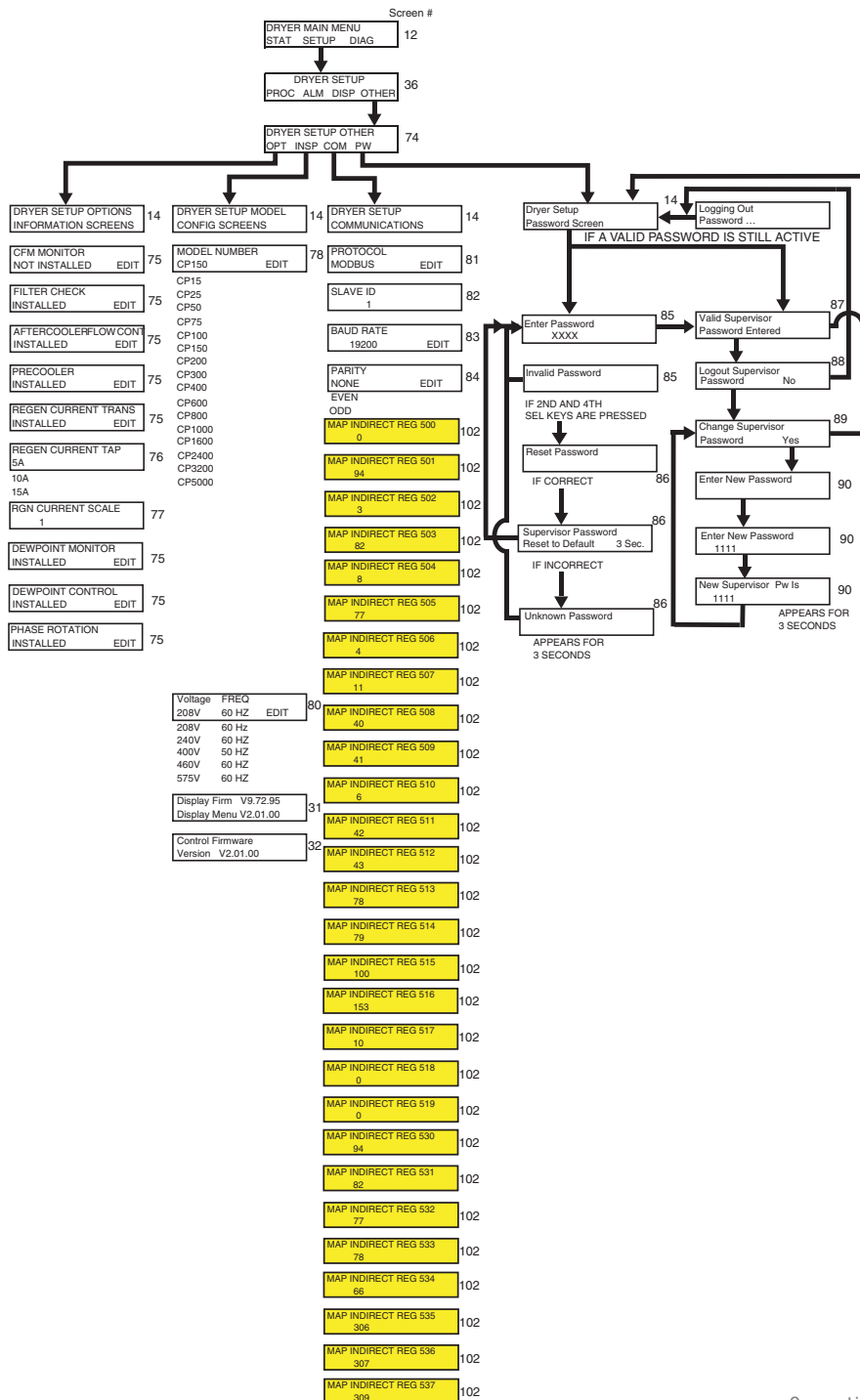

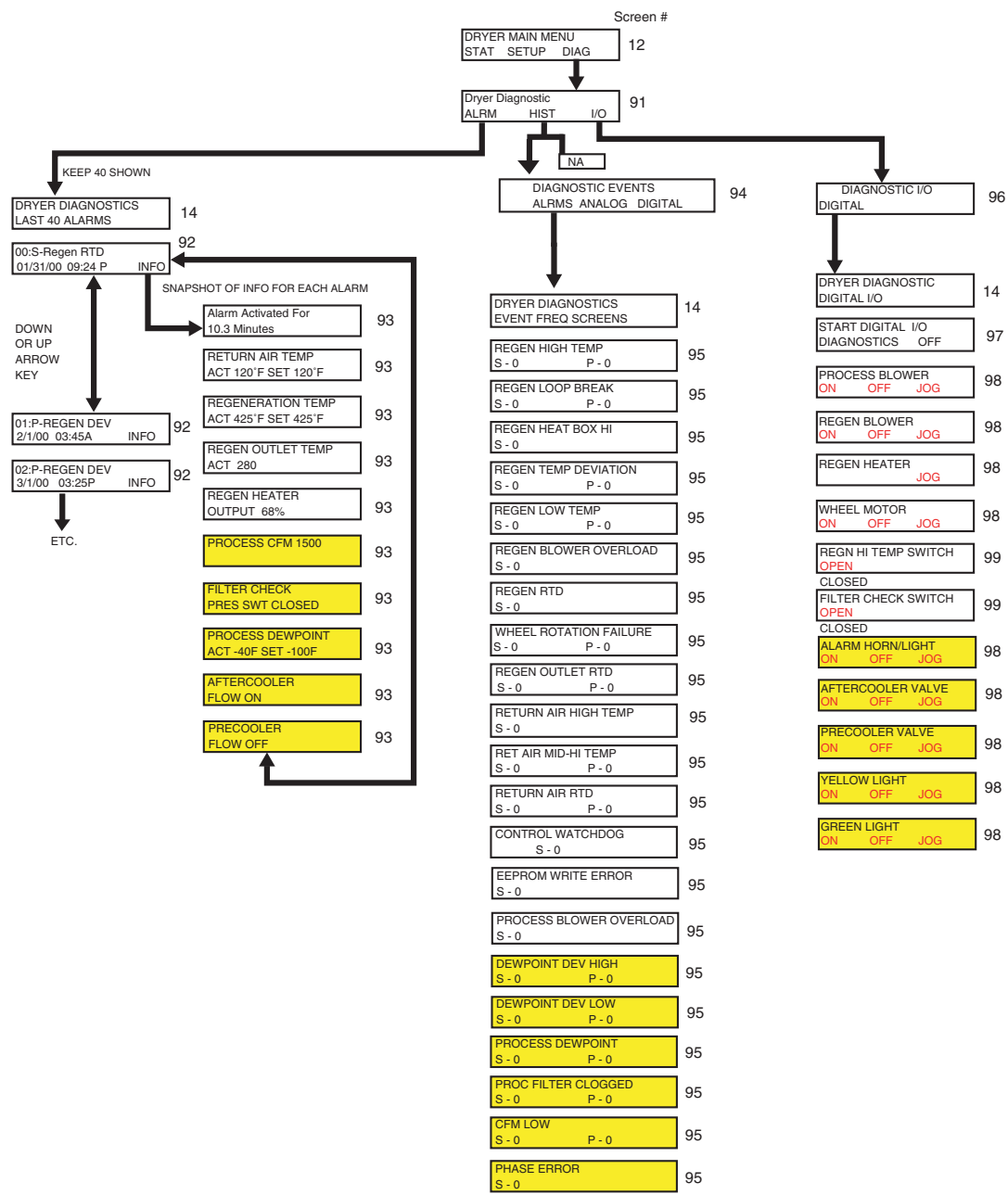

SNAPSHOT OF INFO FOR EACH ALARM

↓

Alarm Activated For  
 10.3 Minutes 93

↓

RETURN AIR TEMP  
 ACT 120° F SET 120° F 93

↓

REGENERATION TEMP  
 ACT 425° F SET 425° F 93

↓

REGEN OUTLET TEMP  
 ACT 280 93

↓

REGEN HEATER  
 OUTPUT 68% 93

↓

PROCESS CFM 1500 93

↓

FILTER CHECK  
 PRES SWT CLOSED 93

↓

PROCESS DEWPOINT  
 ACT -40F SET -100F 93

↓

AFTERCOOLER  
 FLOW ON 93

↓

PRECOOLER  
 FLOW OFF 93

# Control Function Descriptions

## Screen

### SCREEN 1

CONAIR	D100
CV2.21.00	DV2.21.00

### SCREEN 2

MONDAY	
07/22/03	07:59 AM

### SCREEN 4

REGENERATION TEMP	
ACT 350°F	SET 350°F

### SCREEN 5

RETURN AIR TEMP	
ACT 100°F	SET 100°F

## Function

Once power is turned on, this screen is displayed for 3 seconds. It shows CONAIR and the dryer type on the first line, and the control program version and display program version on the second line.

Once power is turned on and screen 1 is displayed for 3 seconds, this screen is displayed for another 3 seconds. It shows the day of the week on the first line and the date and time on the second line. If this information is not correct, it can be changed under the SETUP, DISP, DATE TIME screen 73, page 4-25.

Shows the regeneration air setpoint and actual temperature. The setpoint can be changed with the correct password.



**NOTE:** Lowering the regeneration setpoint decreases the capacity of the dryer and normally is not recommended. Use the dewpoint control function instead.

Shows the actual return air temperature measured at the inlet to the process blower. (The return air temperature on W1600-5000 dryers is measured at the inlet to the desiccant wheel. *W1600-5000 dryers designed prior to August 2007*, the return air temperature is measured at the inlet to the process blower.)  
If the optional aftercooler/intercooler flow control is installed, a setpoint will be displayed on this screen as well. The setpoint can be changed with the correct password.



**NOTE:** The supervisory password is required to change certain parameters. More detail about the password can be found under screen 85, page 4-29.

# Control Function Descriptions (continued)

## Screen

SCREEN 11 Dewpoint Control and/or Dewpoint Monitor

PROCESS DEWPOINT	
ACT -47°F	SET -40°F

SCREEN 12 (MAIN MENU)

DRYER MAIN MENU		
STAT	SETUP	DIAG

## Function

This screen will show the actual dewpoint of the process delivery air measured after the desiccant wheel and before the process heater. The dewpoint control will automatically adjust the regeneration temperature to maintain the dewpoint setpoint.

Dewpoint control is not active with -40°F {-40°C} setpoint. See screen 24, page 4-15 for information about using the dewpoint control or monitor.



**NOTE:** Dewpoint actual will not be live for approximately 5 to 8 minutes.

This is the dryer MAIN MENU. It can be located by pressing the “MENU” key while at the DEFAULT screen. By pressing the Select Category buttons under the titles, the user goes to STATUS screens, SETUP screens, or DIAGNOSTIC

# Control Function Descriptions (continued)

## Screen

## Function

SCREEN 13

DRYER STATUS		
PROC	REGEN	OTHER

screens.

This is the Dryer Status screen. It can be found by pressing the Select Category button under the word "Stat" on the Main Menu screen 12. Any information under the status section is read only; NO CHANGES can be made from the status sections. The operator can select to see status information for Process, Regeneration, or Other.

SCREEN 14

DRYER PROCESS
STATUS SCREEN

This is a column title screen. To navigate to screens within a column (reference the flow charts beginning on page 4-4), the operator must use the scroll buttons, "Prev" or "Next". The "Next" button will scroll one screen at a time down a list of screens. Once the last screen in the list is displayed the "Next" button will return the operator back to this Title screen. When the "Prev" button is pressed, it will scroll one screen at a time up the list of screens. Once the title screen is displayed the "Prev" button will go up to the next high screen, in this case the Dryer Status screen

# Control Function Descriptions (continued)

## Screen

SCREEN 17

TOTAL RUN HOURS  
1250

SCREEN 20

PROCESS CFM 1600

SCREEN 21 (Aftercooler/  
Intercooler Flow Control Option)

AFTERCOOLER  
ENABLED

SCREEN 21 (Aftercooler/  
Intercooler Flow Control Option)

AFTERCOOLER  
FLOW ON

## Function

13.

This screen shows the total run time in hours the dryer has been running since it was new. If the control board is changed during the life of the dryer, this timer will start over.

This is the CFM Monitor screen. It displays the Process CFM. The Process CFM is measured by a differential pressure transducer across the inlet and the outlet of the process blower. The CFM Monitor option must be installed (**see screen 75, page 4-26, also see note on this page**) for this to appear.

This screen shows if the aftercooler/intercooler flow control option is enabled. If the aftercooler/intercooler is disabled, there will be no setpoint for the Return Air Temperature screen 5. The aftercooler/intercooler flow control option must be installed (**see screen 75, page 4-26, also see note on this page**) for this to appear.

This screen shows if the control is opening the solenoid valve. The aftercooler/intercooler flow control option must be installed (**see screen 75, page 4-26, also see note this on page**) for this to appear.



**NOTE:** Screens labeled 75 in the display screen flow chart on page 4-9 are various option installation screens.

# Control Function Descriptions (continued)

## Screen

SCREEN 22 (Current Monitor Option)

REGEN CURRENTS		
84.3 A	84.2 A	84.3 A

SCREEN 23 (Current Monitor Option)

TOTAL POWER
82 KWH

SCREEN 24 Dewpoint Control and Dewpoint Monitor

DEWPOINT CONTROL	
AVG	-55°F

SCREEN 29 (Regeneration Outlet Temperature)

REGEN OUTLET TEMP
ACT 280

## Function

This screen shows the measured current on each leg of the 3-phase power going to the regeneration heater. The Regeneration Current Monitor option (**see screen 75, page 4-26, also see note on this page**) for this to appear.

 **NOTE:** Additional components required for installation.

 **NOTE:** Additional components required for installation.

 **NOTE:** Screens **labeled 75** in the display screen flow chart on page 4-9 are various option installation screens.

This screen shows the calculated total power for the dryer. The calculation includes the measured current for the regeneration heaters, the control voltage set for the dryer, and pre-determined power consumption values for the blowers and the control. The Current Monitor option (**see screen 75, page 4-26, also see note on this page**) for this to appear.

This screen displays the average dewpoint over the last hour of run time.

This screen shows the actual temperature measured at the regeneration outlet of the desiccant wheel manifold.

# Control Function Descriptions (continued)

## Screen

### SCREEN 30

MODEL	CP600-5000
480 V	60 Hz

### SCREEN 31

DISPLAY FIRM	V2.21.00
DISPLAY MENU	V2.21.00

CONTROL FIRMWARE	
VERSION	V2.21.00

AUTOSTART COUNT DOWN	
1 DAYS	23:05:53

AUTOSTOP COUNT DOWN	
3 DAYS	11:04:23

## Function

This screen shows the model number, voltage, and frequency for which the dryer control is setup. These values can be changed with the proper password on screen 85, see page 4-27 (screen 80) under SETUP, OTHER, INSP, Model number (screen 78), and Voltage FREQ (screen 80).

This screen shows the current versions of program for the Display Firmware and Menus.

This screen shows the current versions of program for the Control Firmware.

If the dryer is set with an auto start time, this screen will appear and show the amount of time remaining before the dryer will automatically start. The LED on the front of the display, beside the word Auto Start, will flash if the dryer is set to start automatically. The auto start feature can be programmed under SETUP, PROC, PROC, OTHER (screens 55 and 56, pages 4-20 and 4-21). The dryer can be set to automatically start each day.

If the dryer is set to auto stop, this screen will appear and show the amount of time remaining before the dryer will automatically stop. The auto stop feature can be programmed under SETUP, PROC, OTHER (screens 55 and 57, pages 4-20 and 4-21). The dryer can be set to automatically stop each day.

➤ **Tip:** This information is important to know when ordering a control board.

➤ **Tip:** This information is important to know when ordering a display board.

# Control Function Descriptions (continued)

## Screen

### SCREEN 35

PANEL INSIDE TEMP ACT 100°F
--------------------------------

### SCREEN 36

DRYER SETUP		
PROC	ALM	DISP

### SCREEN 37

SETUP PROCESS		
PROC	REGEN	OTHER

### SCREEN 38

SETUP PROCESS	
PROC	RETPID

## Function

This screen shows the temperature inside the control enclosure. It is measured at the lower right corner of the control board.

This is the Dryer Setup screen. It can be found by pressing the Select Category button under the word Setup on the Main Menu (screen 12). By pressing the Select Category buttons under the titles, the user can select to see setup information for Process, Alarms, Display, or Other.

This is the Setup Process screen. It can be found by pressing the Select Category button under the word "PROC" on the Dryer Setup (screen 36). By pressing the Select Category buttons under the titles, the user can select to see setup information for Process, Regeneration, or Other.

This is the second Setup Process screen. It can be found by pressing the Select Category button under the word "PROC" on the Setup Process screen (37). By pressing the Select Category buttons under the titles, the user can select to see setup information for Process or Return Air PID if the optional aftercooler/intercooler flow control is installed.

## Control Function Descriptions (continued)

### Screen

#### SCREEN 40

PROCESS PID	DONE
AUTOTUNE	OFF

and

REGEN PID	DONE
AUTO	

#### SCREEN 41

REGEN POWER LIMIT	
LOW 2%	HIGH 80%

#### SCREEN 42

REGEN CYCLE TIME
HEAT 2.0 SECONDS

#### SCREEN 43

REGEN PROP BAND
HEAT/COOL 30°F

### Function

Before performing an autotune, set the setpoint to the desired temperature you would like the control to autotune to at screen 3 for process, and screen 4 for regeneration. Screen 40 shows the autotune function for the selected heater. The dryer must not be running to initiate an autotune. The autotune should be started from a cold start or a minimum of 50°F {28°C} difference between starting and autotune temperatures. With the proper password, (see page 4-29, screen 85) press the Select Category button under the word Off. Once selected, the word should start to blink. Press the (+) or (-) button to toggle the Off to On and then press the **“ENTER”** key to start the autotune. The display will show " Wait", then "Heat", then " Done" when it is complete. Pressing **“STOP”** during an autotune will cancel the autotune and not change PID values. The PID values can be set back to factory defaults by going to the Reset (screen 46).

This screen shows the power output range for the heater. It is set by default to 0% for the low and 100% for the high.

This screen shows the PID cycle time for the heater "Heat", or with a precooler "Cool". This time value is the time for one on/off cycle. For example, with a heater running at 50% and the cycle time set at 2 seconds, the heater would be on 1 second and off 1 second.

This screen shows the Proportional Band value for the PID loop.

# Control Function Descriptions (continued)

## Screen

### SCREEN 44

REGEN INTEGRAL	
HEAT/COOL	16.0

This screen shows the integral value for the PID Loop.

### SCREEN 45

REGEN DERIVATIVE	
HEAT/COOL	2.0

This screen shows the derivative value for the PID Loop.

### SCREEN 46

REGEN PID RESET	
HEAT/COOL	

With the proper password, (see page 4-29, screen 85) the PID values can be reset back to the factory default settings.

### SCREEN 47

REGEN CALIBRATION	
OFFSET	2°F

This screen shows the temperature offset for the RTD. This screen is used if the regeneration readout needs to be calibrated.

### SCREEN 48

SETUP REGENERATION	
REGEN	PID

This is the Setup Regeneration screen. It can be found by pressing the Select Category button under the word “Regen” on the Setup Process screen (37). By pressing the Select Category buttons under the titles, the user can select to see setup information for Regeneration or Regeneration PID.

### SCREEN 49

PROCESS DEWPOINT	
SAMPLE RATE	150 SEC

This is the amount of time the control waits before checking the dewpoint value after making a change. This time value gives the system time to respond to a process change.



**NOTE:** Screens 49, 50, 51, 52, 53 and 54 apply only when the dewpoint control is enabled.

## Function

# Control Function Descriptions (continued)



**NOTE:** Screens 49, 50, 51, 52, 53 and 54 apply only when the dewpoint control is enabled.

## Screen

## Function

### SCREEN 50

PROCESS DEWPOINT	
TRIM UP LIMIT	375°F

This is the maximum value the dewpoint control can set the regeneration temperature to achieve the desired dewpoint.

### SCREEN 51

PROCESS DEWPOINT	
TRIM LOW LIMIT	100°F

This is the minimum value the dewpoint control can set the regeneration temperature to achieve the desired dewpoint.

### SCREEN 52

PROCESS DEWPOINT	
GAIN	0.7

This is the proportional gain value for the dewpoint control.

### SCREEN 53

PROCESS DEWPOINT	
DEADBAND	1

This is the deadband range. If the actual dewpoint value is within this range of the dewpoint setpoint, the control will not make a change to the regeneration temperature.

### SCREEN 54

PROCESS DEWPOINT	
CONTROL RESET	

This will reset the dewpoint control back to the factory default values.

### SCREEN 55

AUTO START TIMER	
ENABLED	EDIT

This screen is used to enable or disable the auto start function. If the function is enabled, the dryer can be started or stopped once each day. The start and stop times can be set on screens 56 and 57 (page 4-21). The auto start can be enabled or disabled with the proper password (screen 85, page 4-29).

# Control Function Descriptions (continued)

## Screen

SCREEN 56

MONDAY START TIME	
ON	8:00 AM

SCREEN 57

MONDAY STOP TIME	
ON	8:00 PM

## Function

This is the auto start screen for the first day of the week. Each day has a screen similar to this. By pressing the Select Category button under On or Off, the dryer can be set to start on Monday. The start time can be set by pressing the Select Category button under time and entering a new time on the numeric keypad. The AM / PM can be changed only after a time value has been entered. The (+) button will set PM and the (-) button will set AM. The “ENTER” key must be pressed to lock in the new time. The dryer can be manually started at anytime. If the auto start time runs out and the dryer has been manually started, nothing will happen.

This is the auto stop screen for the first day of the week. Each day has a screen similar to this. By pressing the Select Category button under On or Off, the dryer can be set to stop on Monday. The stop time can be set by pressing the Select Category button under time and entering a new time on the numeric keypad. The AM / PM can be changed only after a time value has been entered. The (+) button will set PM and the (-) button will set AM. The “ENTER” key must be pressed to lock in the new time. If the auto stop time runs out and the dryer has already been manually stopped, nothing will happen. If the dryer was auto started on Monday morning and the Monday auto stop is set to off, the dryer will continue running until it hits a day of the week when the auto stop is set to On. At that time the dryer will turn off.



**NOTE:** Screens 56 and 57 require the supervisor's password.

# Control Function Descriptions (continued)

## Screen

SCREEN 58

ALARM	ALARM
ACTION	SETUP

SCREEN 59

REGEN TEMP DEVIATION			
ON	EDIT	PASS	EDIT

SCREEN 60

REGEN HIGH TEMP	
250°F	1 SEC

## Function

This is the alarm action and setup screen. With the proper password, (see page 4-29, screen 85) the Select Category button can be pressed under Alarm Action or Alarm Setup. Alarm Action screens can be used to change whether an alarm is Off, Passive, or Shutdown (screen 59). Alarm Setup screens can be used to change alarm setpoints and delay times. (screens 60-70)

This is an example of the Alarm Action screens. With the proper password, (see page 4-29, screen 85) some alarms can be turned on or off by either pressing the Select Category button under the word Edit, or by pressing the Select Category button under the word On or Off. Once the word begins to blink, the (+) or (-) keys will change the setting. The “ENTER” key must be pressed to lock in the value. The same sequence works for the “Pass” or “Shut” words. “Pass” or Passive means the alarm will not shut the dryer down but the alarm will be logged in the Dryer Diagnostics Alarm Log. A “Shut” means Shutdown, in which case the dryer would shut down if the alarm occurs.

This is an example of an Alarm Setup screen that has a minimum or maximum temperature. With the proper password, (see page 4-29, screen 85, refer to password) the temperature setpoint can be changed as well as how long the dryer has to stay at that temperature before alarming.

# Control Function Descriptions (continued)

## Screen

SCREEN 61

REGEN LOOP BREAK
2°F                      40 SEC

SCREEN 62

REGEN TEMP DEV
10°F                      5 Sec

SCREEN 63

REGEN DIFFERENTIAL
20°F                      10 SEC

SCREEN 64

REGEN DIFFERENTIAL
TIME DELAY              5 MIN

RETURN AIR ALARMS
PASS 150°F              SHUT 180°F

## Function

This is an example of an Alarm Setup Loop Break screen. When actual temperature is outside the deviation band, if the temperature is not moving toward the setpoint at a rate greater than or equal to X°F over Y seconds, then the dryer will alarm on Loop Break. Once the actual temperature is within the deviation band, the Loop Break is ignored.

This is an example of an Alarm Setup deviation screen. If the actual temperature goes outside this temperature band (High or Low) for a set amount of time, the dryer will give a deviation alarm. With the proper password (see page 4-29, screen 85), these values can be changed.

This set value is the minimum difference between the regeneration inlet and outlet temperature for the wheel rotation alarm. Once this difference is reached for the set time value, the dryer will alarm wheel rotation failure.

This is a delay time from start-up so regeneration can come up to temperature.

This screen shows the return air temperatures at which the dryer will give a passive alarm, and when the dryer will shutdown on High Return Air Temp.

## Control Function Descriptions (continued)

### Screen

SCREEN 66 (CFM Monitor Option)

CFM LOW SETPOINT

1430

SCREEN 67 (Dewpoint Monitor or Dewpoint Control)

DEWPOINT ALARM

ACT -40°F      180 SEC

SCREEN 68 (Dewpoint Control Enabled)

DEWPOINT DEVIATION

HIGH    5°F      30 SEC

SCREEN 69 (Dewpoint Control Enabled)

DEWPOINT DEVIATION

LOW 5°F      30 SEC

### Function

This screen shows the low CFM setpoint. The default is 1 CFM. The default can be changed with the proper password (see page 4-29, screen 85).

This screen shows the alarm setpoint for a Dewpoint alarm. With the proper password, it can be changed (see page 4-29, screen 85). The defaults are -3°F for 180 seconds. If the control senses -3°F or higher for 180 seconds, the dryer will alarm.

This is the dewpoint high deviation alarm value. With the proper password, it can be changed (see page 4-29, screen 85). When in dewpoint control, if the actual dewpoint goes above the setpoint in screen 11, page 4-12, for the set amount of time, the dryer will alarm “Dewpoint Deviation High”.

This is the dewpoint low deviation alarm value. With the proper password, it can be changed (see page 4-29, screen 85). When in dewpoint control, if the actual dewpoint goes below the setpoint in screen 11, page 4-12, by this value for this amount of time, the dryer will alarm “Dewpoint Deviation Low”.

# Control Function Descriptions (continued)

## Screen

SCREEN 70

DEWPOINT		
TIME	DELAY	5 MIN

SCREEN 71

UNITS	
STANDARD	EDIT

SCREEN 72

TIME DISPLAY
12 HOUR

SCREEN 73

DATE	TIME
10/25/2004 MON	10:33 AM

## Function

This is the amount of time from start-up the dryer is allowed to run before the control will try to control the dewpoint. Five minutes is the default. This gives the dryer time to warm up and reach a steady state. It can be changed with the proper password (see page 4-29, screen 85).

This screen shows the units the dryer will display. It can be changed with the proper password (see page 4-29, screen 85) to either Standard or Metric. Press the Select Category button below the word Edit to change the setting and press the **“ENTER”** key to lock in the value.

This screen shows the time unit the dryer will display. It can be changed with the proper password (see page 4-29, screen 85) to either 12 hour (AM / PM Clock) or 24 hour (Military Time). Press the Select Category button below the words 12 hour to change the setting and press the **“ENTER”** key to lock in the value.

This screen shows the date and time. With the proper password, (see page 4-29, screen 85) the date and time can be changed.

# Control Function Descriptions (continued)

## Screen

SCREEN 74

DRYER SETUP OTHER			
OPT	INSP	COM	PW

## Function

This is the Dryer Setup Other screen. It can be found by pressing the Select Category button under the word Other on the Dryer Setup Screen (36). By pressing the Select Category buttons under the titles, the user can select to see setup information for Options, Inspection, Communications, or Password.



**NOTE:** Screens labeled 75 in the display screen flow chart on page 4-9 are various option installation screens.

SCREEN 75

CFM MONITOR	
NOT INSTALLED	EDIT

This is an example of an Option Installation screen. With the proper password (see page 4-29, screen 85) and hardware installed, an option can be turned on by pressing the Select Category screen under the word Edit. This will change an option from Not Installed to Installed. The “ENTER” key must be pressed to lock in the change. Once an option is installed, there may be additional screens that show in the menu structure that need to be setup.

SCREEN 76 (Current Monitor Option)

REGEN CURRENT	TAP
5 A	

This screen is used with the current monitor option and tells the control which tap is used on the current sensing board (5A, 10A, or 15A).

SCREEN 77 (Current Monitor Option)

REGEN CURRENT SCALE
1

This screen is used with the current monitor option and is used to scale the reading to the proper reading.

# Control Function Descriptions (continued)

## Screen

SCREEN 78

MODEL NUMBER	
CP600	EDIT

SCREEN 80

VOLTAGE	FREQ	
208 V	60 HZ	EDIT

## Function

This screen further defines the dryer type to a model number. Based on the dryer type, the selections on this menu will change. Your dryer should be configured from the factory. However, if the control was replaced, the control may need to be reconfigured. With the proper password, (see page 4-29, screen 85) the Model Number can be changed by pressing the Select Category button under the word Edit. The **“ENTER”** key must be pressed to lock in the selection.

This screen defines the voltage and frequency at which the dryer will be running. This setting should match the electrical label on the side of the control box. Your dryer should have been configured from the factory. However, if the control was replaced or the dryer was configured to run on another voltage, this screen may need to be reconfigured. With the proper password, (see page 4-29, screen 85) the Voltage and Freq can be changed by pressing the Select Category button under the word Edit. The **“ENTER”** key must be pressed to lock in the selection.

# Control Function Descriptions (continued)

## Screen

### SCREEN 81 Communications

PROTOCOL	
DEVICENET	EDIT

### SCREEN 82 Communications

SLAVE ID	
1	EDIT

### SCREEN 83 Communications

BAUD RATE	
9600	EDIT

### SCREEN 84 Communications

PARITY	
NONE	EDIT

## Function

This screen shows the communications protocol. Modbus, DeviceNet, Ethernet or SPI is available. This is set at the factory. If adding to an existing dryer, the communications protocol can be changed with the proper password (see page 4-29, screen 85).

This screen shows the Slave ID number. The ID number can be changed with the proper password (see page 4-29, screen 85) by pressing the Select Category button below the word Edit and entering a value on the keypad or scrolling to the desired value using the Adjust Setpoint keys. The **“ENTER”** key needs to be pressed to lock in the new number.

This screen shows the baud rate. The baud rate can be changed with the proper password (see page 4-29 screen 85). Press the Select Category key below the word Edit and enter a value on the keypad or scroll to the desired value using the Adjust Setpoint keys.

This screen shows the parity. The parity can be changed with the proper password (see page 4-29, screen 85) to Even, Odd, or None by pressing the Select Category button below the word Edit. The **“ENTER”** key needs to be pressed to lock in the new number.

# Control Function Descriptions (continued)

## Screen

### SCREEN 85

ENTER PASSWORD  
0210

## Function

This screen shows the password entry screen. You can enter a password by using the keypad. Once a password has been entered the “ENTER” key must be pressed. If the password is valid, the display will show screen 87. If the password was incorrect, it will display "Invalid Password Try Again" and go back to the Enter Password screen. The default supervisor password is 0210. The supervisor can change this password by going to screen 89.

### SCREEN 86

RESET PASSWORD

This is the Reset Password screen. It will only be shown when the second and fourth Select Category buttons are pressed at the same time when at screen 85. You can enter the default password by using the keypad. Once the default password has been entered, the “ENTER” key must be pressed. This will change the password back to the factory default password (see page 4-29, screen 85). If the password has been changed see screens 89 and 90.

### SCREEN 87

VALID SUPERVISOR  
PASSWORD ENTERED

This is the display screen that appears when a valid password has been entered. Pressing the Previous button will take you to screen 14. Pressing “Next” will take you to screen 88.

# Control Function Descriptions (continued)

## Screen

SCREEN 88

LOGOUT SUPERVISOR		
PASSWORD		YES

SCREEN 89

CHANGE SUPERVISOR		
PASSWORD		YES

SCREEN 90

ENTER NEW PASSWORD		
--------------------	--	--

SCREEN 91

DRYER DIAGNOSTIC		
ALRM	HIST	I/O

## Function

This is the password logout screen. If nothing is done, the password will automatically be logged out after 30 minutes. To logout, use the Select Category button under the word Yes/No. Setting it to Yes and hitting the “**ENTER**” Key will change the display to "Logging Out Password" for 3 seconds then will automatically go to screen 14.

This screen allows the supervisor to change the password. To change the password, use the Select Category button under the word, Yes/No. Setting it to yes and hitting the “**ENTER**” Key will change the display to screen 90. If the user does not want to change the password, by pressing the “**Next**” key the control will return to the Dryer Setup Password screen 14.

This screen shows the password entry screen. You can enter a new password by using the key pad. Once a new password has been entered the “**ENTER**” key must be pressed. The display will show the new password for 3 seconds then return to the Change Supervisor Password (screen 89). To exit, press the “**Next**” key and the control will return to the Dryer Setup Password Screen.

This is the Dryer Diagnostic screen. It can be found by pressing the Select Category button under the word Diag on the Dryer Main Menu screen 12. By pressing the Select Category buttons under the titles, the user can select to see diagnostic information for Alarms, Alarm History, or Inputs and Outputs.

# Control Function Descriptions (continued)

## Screen

SCREEN 92

00:S-REGEN RTD	
1/31/00 09:24 P	INFO

SCREEN 93

ALARM ACTIVATED FOR
10.3 MINUTES

SCREEN 94

DIAGNOSTIC EVENTS
ALARMS

SCREEN 95

REGEN HIGH TEMP	
S - 0	P - 0

## Function

This is an example of one of the alarm history screens. The first two numbers of the first line show what alarm you are viewing in the list. This example is the first alarm in the list 00. The letter after the : P or : S shows if the alarm was a passive or shutdown alarm. The second line shows the date and time when the alarm occurred. By pressing the Select Category button under the word Info, the display can show a number of screens that are a snapshot of information that was happening when the alarm occurred.

This is an example of one of the Information screens for an alarm. This is the first screen under the Info shown on screen 92. It shows how long the alarm was active. The time shown is from when the alarm occurred until the alarm was acknowledged and cleared. The “Next” button can be pressed while at this screen to see other items in the list of snapshot info that was happening when the alarm occurred.

This is the Dryer Diagnostic screen. It can be found by pressing the Select Category button under the word Hist on the Dryer Diagnostics screen (91). By pressing the Select Category buttons under the alarms, the user can select to see diagnostic information for Alarms.

This is an example of the Event Freq. screens. This shows the number of times an alarm has occurred. By pressing the next key in this section, the user can see info for all alarms. The “S” indicates how many times it was a shutdown alarm and the “P” indicates how many times it was a passive alarm.

# Control Function Descriptions (continued)

## Screen

SCREEN 96

DIAGNOSTIC I/O DIGITAL
---------------------------

SCREEN 97

START DIGITAL I/O DIAGNOSTICS	OFF
----------------------------------	-----

SCREEN 98

PROCESS BLOWER		
ON	OFF	JOG

SCREEN 99

PROC OPEN
--------------

## Function

This is the Diagnostic I/O screen. It can be found by pressing the Select Category button under the word I/O on the Dryer Diagnostics screen (91). By pressing the Select Category button under Digital, the user can access the digital outputs (screen 98) and view the status of the digital inputs (screen 99). The analog diagnostic I/O function is not used.

This screen is used to enter the diagnostic mode where outputs can be turned on (screen 98) or the state of the inputs monitored (screen 99). Note that the dryer **MUST NOT BE** running to enter diagnostics. The supervisor password is necessary (screen 85, page 4-29).

This is an example of one of the digital outputs that can be manually energized. All screens in this section only work when the dryer is not running and is in “stand-by”. The outputs can be turned on, turned off, or energized for a 3-second jog (automatically turned on for 3 seconds then turned off). The process and regeneration heaters can only be jogged for 3 seconds, and the wheel motor, if jogged, will rotate the wheel for 3 seconds. If the stop button is pressed at any time during this testing, the output will stop immediately.

This is an example of one of the digital Inputs screens. This will show if the input is open or closed.

# Control Function Descriptions (continued)

## Screen

SCREEN 102

MAP INDIRECT REG 500

0

## Function

These parameters map which internal variables are accessible from the user communication port on the DC-2 operator display. A default set of variables has been chosen that represent the most important variables for the majority of uses. These values should NOT be changed except under the direction of Conair Engineering or Service.

# To Start Drying

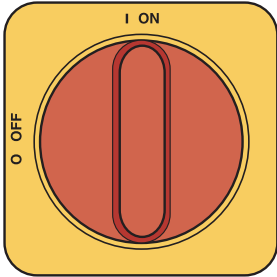

**1** Make sure there is material in the hopper.

**2** Turn on the main power to the dryer. Make sure the dryer's disconnect dial is in the ON position. This powers up the control and the display lights will illuminate.



**NOTE:** When changing a setpoint use the Select Category Key directly below the value to be changed. Once pressed the value will blink, then use the keypads or (+) (-) adjustment setpoints to enter the new value. Then press enter for the new value to be recognized.



**NOTE:** Once the dryer has been started, go to the ResinWorks or HTC and set the setpoint then turn on the unit.

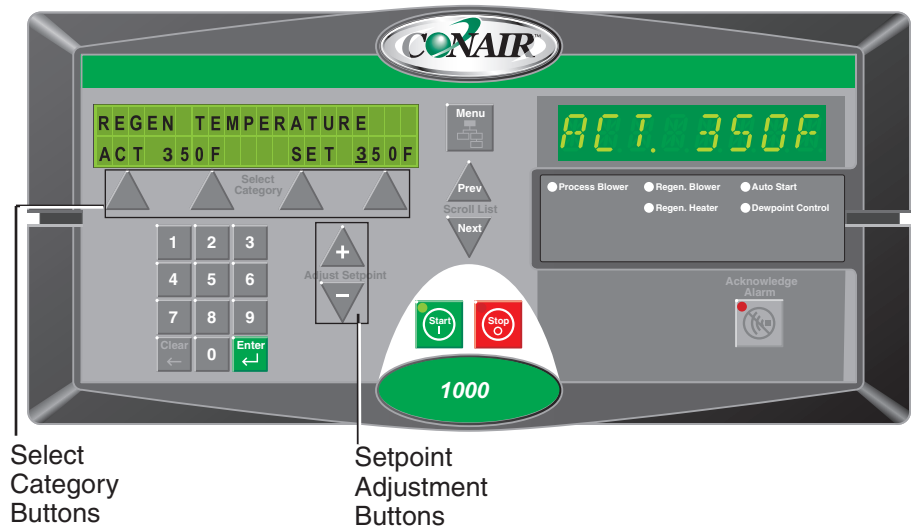

(continued)

## To Start Drying (continued)

### 3 Press the START button.



If everything is installed correctly:

- The green light on the start button will illuminate.
- The process and regeneration blowers turn on and the display LEDs will illuminate.
- The regeneration heater turns on and the display LED will illuminate.
- The desiccant wheel starts turning.

## To Stop Drying



**NOTE:** Turn off the ResinWorks or HTC and allow the heaters to cool (3 to 5 minutes) before turning off the dryer.

### 1 Press the STOP button. The Stop LED blinks



- The blowers continue running for a few minutes to cool the heaters.

### 2 Be sure to disconnect and lockout the main power if you have stopped the dryer to perform maintenance or repair.

**IMPORTANT:** Do not use the main power switch to stop the dryer. Turning off power to the control and dryer during normal operation prevents the necessary cool-down period, and can trigger the shut down/high temperature alarm during your next drying cycle.



**Caution:** Improper shut down can cause damage to your dryer.

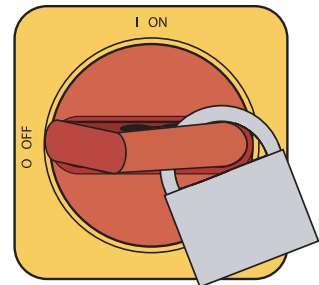

# How to Use the Supervisor's Password

The supervisor's password must be entered before you can use or make changes to some screens on the dryer control. To enter the supervisor password:

- 1** Go to screen 12 and press the **Select Category** button under "SET UP."

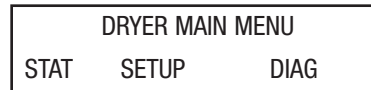

- 2** This will take you to screen 36. **On Screen 36, press the Select Category button** under "other."

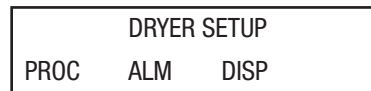

- 3** This will take you to screen 74. **On Screen 74, press the Select Category button** under "PW."

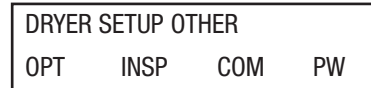

- 4** This will take you to screen 14. **On Screen 14, press the Scroll List Next button.** This will take you to screen 85.

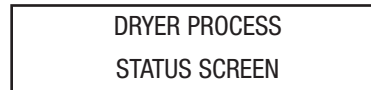

- 5** **This is the screen where you will need to enter the supervisor's password.** The default supervisory password is 0210. Enter this number to make changes to screens where the supervisor's password is necessary to use or change a function of the dryer.

(continued)

# How to Use the Supervisor's Password (continued)

Be sure to push “ENTER” after entering the password. If the password is entered successfully, screen 87 will be displayed.

VALID SUPERVISOR PASSWORD ENTERED
--------------------------------------

Once the desired parameter has been changed, follow the previous steps to go to screen 88.

LOGOUT SUPERVISOR PASSWORD	YES
-------------------------------	-----

Push the Select Category button under “No”. Once it begins to flash, push either the Adjust Setpoint button to display “Yes”, then push “ENTER”. Push the Menu button to return to the main display.



**NOTE:** The supervisor's password can be changed by going to screen 89, see page 4-4, for the map of the screens. See page 4-30, screen 89 for additional information on changing the supervisory password.

# Using the Dewpoint Monitor and Dewpoint Control

Your dryer is equipped with a dewpoint monitor and dewpoint control features. You can choose to use it as a monitor only device, or to maintain a steady dewpoint that you select with the dewpoint control. Dewpoint control will vary the regeneration air temperature to condition the desiccant to the level necessary to maintain the desired dewpoint.

## Dewpoint Monitor



**NOTE:** The supervisor's password is necessary. Please refer to the “Using the Supervisor's Password” section on page 4-36.

From “Dryer Main Menu”, select “Setup, Other OPT” to get to the “Dryer Setup Options Information” (screen 14, page 4-13). Proceed to screen 75 (page 4-26). “Dewpoint Monitor” must be set to “Installed” and “Dewpoint Control” set to “Not Installed”. Screen 11 (page 4-12) will display the actual dewpoint readout.

## Dewpoint Control



**NOTE:** The supervisor's password is necessary. Please refer to the “Using the Supervisor's Password” section on page 4-36.

From “Dryer Main Menu”, select “Setup, Other OPT” to get to the “Dryer Setup Options Information” (screen 14, page 4-13). Proceed to screen 75 (page 4-26). “Dewpoint Control” must be set to “Installed”. “Dewpoint Monitor” can be set to “Installed” or “Not Installed”. Screen 11 (page 4-12) will display the actual dewpoint and the dewpoint setpoint the dryer is to maintain.



**NOTE:** Dewpoint control is inactive when the dewpoint setpoint is  $-40^{\circ}\text{ F}$  { $-40^{\circ}\text{ C}$ }.



**NOTE:** For more information concerning specific dewpoint control screens, see Control Function Descriptions, page 4-11.

# Using the Auto Start Timer

You can set the dryer to start and stop automatically using the Auto Start and Auto Stop functions. Supervisor Password (screen 85, page 4-29) is necessary to use this function.



**NOTE:** To use the Auto Start Timer, you must have the Auto Start function enabled (screen 55, page 4-20).

## Programming Auto Start

The Auto Start time and day can be programmed using the Auto Start Countdown screen. This screen can be accessed under the SETUP, PROC, and OTHER screens **from the “Dryer Main Menu” screen 12:**

SCREEN 36

Dryer Setup			
Proc	Alm	Disp	Other

SCREEN 37

Setup Process		
Proc	Regen	Other

SCREEN 56

MONDAY START TIME	
ON	8:00 AM

Once the Auto Start time and day has been programmed, the Auto Start Countdown screen (screen 33) will show the amount of time remaining before the dryer will automatically start. The LED on the front of the display beside the word Auto Start will flash if the dryer is set to start automatically. The dryer can be set to automatically start each day.

## Programming Auto Stop

The Auto Stop time and day can be programmed using the Auto Stop Countdown screen. This screen can be accessed under the SETUP, PROC, and OTHER screens **from the “Dryer Main Menu” screen 12:**

SCREEN 36

Dryer Setup			
Proc	Alm	Disp	Other

SCREEN 37

Setup Process		
Proc	Regen	Other

SCREEN 57

MONDAY STOP TIME	
ON	8:00 PM

Once the Auto Stop time and day has been programmed, the Auto Stop Countdown screen (screen 34) will show the amount of time remaining before the dryer will automatically stop. The dryer can be set to automatically stop each day.



# Maintenance

---

Preventative maintenance checklist . . . . .	5-2
Checking the dewpoint. . . . .	5-3
Cleaning the hopper. . . . .	5-5
Cleaning the process filter . . . . .	5-6
Cleaning the regeneration filter. . . . .	5-8
Cleaning the aftercooler/intercooler coils . . .	5-9
Cleaning the precooler coils (W600-5000) . .	5-11
Cleaning the volatile trap on the demister . .	5-11
Inspecting hoses and gaskets . . . . .	5-11

# Preventative Maintenance Checklist

Routine maintenance will ensure optimum operation and performance of the W Series Carousel Plus Dryer. We recommend the following maintenance schedule and tasks.

- **Whenever you change materials**

- Drain and clean the hopper.**

- **Weekly, or as often as needed**

- Clean or replace the process and regeneration filters.**

You may need to clean filters more often than weekly. Frequency depends on how much material you process and how dusty or full of fines it is.

- Inspect hoses and hose connections.**

Check for damage, kinks, or loose hose clamps. Replace any hoses that show signs of damage or wear. Reposition and tighten loose hose clamps.

- **Monthly**

- Clean the aftercooler/intercooler and/or optional precooler coils.**

You may need to clean the coils more often than monthly. Frequency will depend on the type and volume of material you process.

- **Every six months**

- Inspect gaskets for damage or wear.**

Damaged gaskets can allow moisture to seep into the closed-loop drying system. Replace any gasket that is torn or cracked.

- Inspect the overhead process air duct connections.**

**(W3200-5000)** Ensure that all connections are tighten properly and have no air leaks.

- Verify dewpoint readout and performance with calibrated portable instrument.**

- Measure current draw on all 3 legs of heater wires.** This is to ensure that the heater is working properly.

# Checking the Dewpoint

It is a good idea to monitor the dewpoint performance of your dryer periodically with a calibrated portable dewpoint monitor, to ensure it is performing at maximum capacity. Even if your dryer has a dewpoint readout, comparing it to a portable instrument periodically will confirm that the dewpoint sensor and readout is performing properly.

## To check dewpoint:

- 1 Connect your portable dewpoint meter to the dewpoint check port of the dryer.**
- 2 Turn on the portable instrument,** and ensure there is positive airflow through the sensor.
- 3 Monitor the readout and allow ample time for it to stabilize before disconnecting the portable dewpoint monitor.** Some dewpoint monitors require a substantial amount of time for residual moisture to be purged from the sensor.
- 4 In the event the dewpoint is not satisfactory,** refer to the *Troubleshooting section* of the manual, under Process Dewpoint alarm for DC2.



**NOTE:** Portable dewpoint monitors purchased from Conair are provided with a male connector that plugs into the dewpoint check port. If you purchased your portable instrument elsewhere, the male connector is available through the Conair parts department.



**NOTE:** The dewpoint check port was not included on the initial release of these dryers. It can be added easily. Contact the Conair parts department or follow the alternate procedure.

## Alternate Procedure: (for dryers with no dewpoint check port)

- 1 Stop dryer and allow it to cool.**
- 2 Swing open or remove the left side panel.** See *Installation section entitled, Opening the dryer doors (W1600-5000)*.
- 3 Remove the 1/8 inch NPT pipe plug at the process air outlet** on the bottom manifold of the desiccant wheel assembly.
- 4 Connect a portable dewpoint meter** to the hole from which the plug was just removed.

**Replacement dewpoint monitors, male connectors and dewpoint check ports are available from Conair.**

Contact Conair Parts  
(800) 458 1960  
From outside of the  
United States, call:  
(814) 437 6861

## Checking the Dewpoint (continued)

- 5** Turn on the portable instrument, and ensure there is positive airflow through the sensor.
- 6** Monitor the readout and allow ample time for it to stabilize before disconnecting the portable instrument. Some dewpoint monitors require a substantial amount of time for residual moisture to be purged from the sensor.
- 7** In the event the dewpoint is not satisfactory, refer to the *Troubleshooting section* of the manual, under Process Dewpoint alarm for DC2.
- 8** Stop the dryer, and allow it to cool down. Then disconnect your portable instrument and replace any pipe plugs that may have been removed.
- 9** Close or replace the side panel.

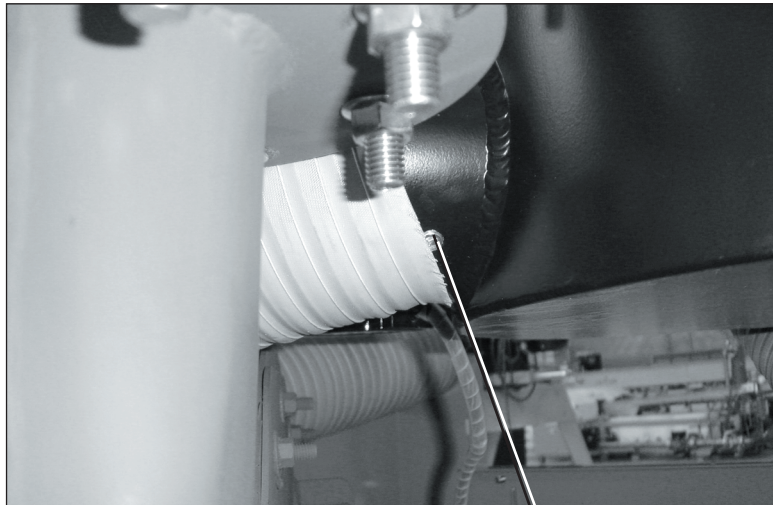

1/8 inch NPT Hole Plug

# Cleaning the Hopper



**CAUTION: Hot surfaces.** Always protect yourself from hot surfaces inside and outside the dryer and drying hopper.

The hopper, spreader cone, and discharge assembly should be cleaned thoroughly between material changes to prevent resin contamination.

- 1 Close the hopper slide gate.**
- 2 Place a container beneath the hopper's drain port** to catch the material.
- 3 Open the drain port** and allow the material to drain.
- 4 Open the hopper door and wipe out the inside** of the hopper.
- 5 Clean the return air screen** at the return air outlet of the hopper.



**CAUTION: Wear eye protection.** If you use compressed air to clean the equipment, **you must wear eye protection** and observe all OSHA and other safety regulations pertaining to the use of compressed air.

- 6 Remove the container from beneath the hopper and replace the drain port cover** before filling the hopper with material.

# Cleaning the Process Filter

Clogged filters reduce air flow and dryer efficiency. Cleaning frequency depends on how much material you process and how dusty or full of fines it is.

## *Carousel Plus W-series Dryers 600-1000*



**CAUTION: Hot surfaces.**  
Always protect yourself from hot surfaces inside and outside the dryer and drying hopper.



- 1 Push in on the sides** to release the tabs on the front cover. Remove the cover.



**NOTE:** Larger dryer models (W1600 - 5000) do not have covers.



- 2 Remove the cover wing nut**, then pull the filter cap off.

## *Carousel Plus W-series Dryers 1600-5000*



- 2a Remove the four (4) filter cap cover latches**, then pull the filter cap off.

Process Fitter Cap Latch (4)

(continued)

# Cleaning the Process Filter (continued)

## Carousel Plus W-series Dryers 600-5000

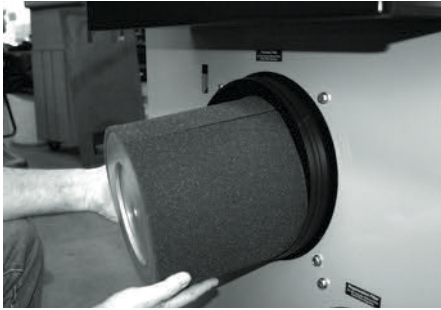

- 3** Remove the filter wing nut, then remove the filter.



- 4** Remove outer filter and clean it with soapy water. Let air dry.



**NOTE:** On models W1600-5000 the process filter will not have an outer filter.

- 5** Clean the filter by laying it on its side and gently tapping it on the floor. Replace damaged, worn, or clogged filters.

- 6** Reverse the procedure to reinstall the process filter. Ensure that the gasket on filter cap is in place and in good condition.



**CAUTION:** Wear eye protection. If you use compressed air to clean the equipment, **you must wear eye protection** and observe all OSHA and other safety regulations pertaining to the use of compressed air.



**TIP:** If gasket on the process filter cap becomes loose or detached from the filter cap, resecure with high temperature silicone adhesive.

# Cleaning the Regeneration Filter

Clogged filters reduce air flow and dryer efficiency. Cleaning frequency depends on the condition of your dryer's ambient air.



**CAUTION: Hot surfaces.**

Always protect yourself from hot surfaces inside and outside the dryer and drying hopper.



- 1 Push in on the sides** to release the tabs on the front cover. Remove the cover.



**NOTE:** Larger dryer models (W1600 - 5000) do not have covers.



- 2 Remove the filter wing nut**, then remove the filter.



- 3 Remove outer filter** and clean it with soapy water. Let air dry.
- 4 Clean the filter by laying it on its side and gently tapping it on the floor.** Replace damaged, worn, or clogged filters.
- 5 Reverse the procedure to reinstall the regeneration filter.**



**CAUTION: Wear eye protection.** If you use compressed air to clean the equipment, **you must wear eye protection** and observe all OSHA and other safety regulations pertaining to the use of compressed air.

# Cleaning the Aftercooler/ Intercooler Coils

You need to clean the aftercooler/intercooler coils to keep them working efficiently. Cleaning frequency depends on the type and amount of material you process.

**1 Stop the dryer and lockout the main power.**



**2 Turn off the water flow to the water supply line.** Disconnect supply and return lines.

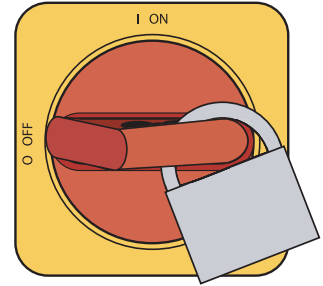

**NOTE:** If an optional flow control was added with the aftercooler/intercooler, remove the compression fitting from the aftercooler/intercooler inlet. Loosen the fitting on the flow control, then swing the copper water supply tube out and away from the aftercooler/intercooler inlet.

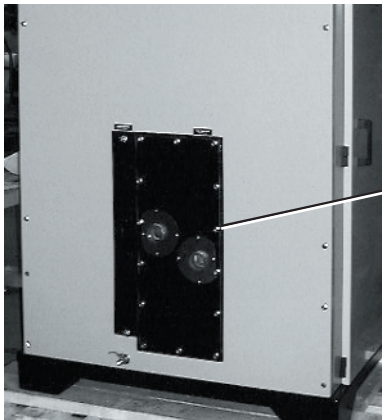

W600 - 1000  
Models

W1600 - 5000  
Models



**3 Remove the bolts securing the aftercooler/intercooler cover.** Remove the cover.

**4 Remove the aftercooler/intercooler by pulling it out** of the aftercooler/intercooler housing.

(continued)

## Cleaning the Aftercooler/ Intercooler Coils (continued)

**5 Clean the assembly using a mild soap and water.** Let the assembly dry thoroughly before installation.



**NOTE:** In cases of heavy volatiles, steam cleaning or the use of solvents, such as acetone, may be necessary. Be sure to test a small area with the solvent you have selected to be sure there is no adverse reaction.

**6 Inspect the condition of the gasket.** If it is damaged, replace the gasket.

**7 Reassemble** by repeating the steps in reverse order.

**8 Connect the water supply line to the inlet.** If a manual shut off valve is used, it should be mounted on the inlet line as well.

**9 Connect the outlet of the aftercooler/intercooler to the inlet of the flow control valve** using the pre-shaped copper tubing and compression fittings provided.

## Cleaning the Precooler Coils

You need to clean the precooler cooling coils to keep them working efficiently. See Appendix B for details.

## Cleaning the Volatile Trap on the Demister

If you have the optional volatile trap, you need to clean the trap to keep it working efficiently. See Appendix C for details.

## Inspecting Hoses and Gaskets

Loose or damaged hoses and gaskets can allow moisture to seep into the closed-loop drying system.

- 1 Follow the hose routing of all the hoses within the dryer and inspect all hoses, clamps, fittings, and gaskets.**
- 2 Tighten any loose hose clamps or fittings.**
- 3 Replace worn or damaged hoses and gaskets.**



# Troubleshooting

---



Before beginning . . . . .	6-2
A few words of caution . . . . .	6-3
<b><u>DIAGNOSTICS</u></b>	
How to identify the cause of a problem . . . . .	6-4
Shutdown alarms . . . . .	6-5
Passive alarms . . . . .	6-9
Dewpoint troubleshooting . . . . .	6-15
Poor material drying troubleshooting . . . . .	6-16
<b><u>REPAIR</u></b>	
Replacing fuses . . . . .	6-21
Checking heater solid state relays . . . . .	6-22
Checking or replacing temperature sensors . . . . .	6-23
Replacing the regeneration heater (W600-1000) . . . . .	6-24
Replacing the regeneration heater (W1600-2400) . . . . .	6-26
Replacing the regeneration heater (W3200-5000) . . . . .	6-28
Replacing the desiccant wheel assembly (W600-1000) . . . . .	6-30
Replacing the desiccant wheel motor (W600-1000) . . . . .	6-32
Replacing the desiccant wheel motor (W1600 - 5000) . . . . .	6-33

# Before Beginning

You can avoid most problems by following the recommended installation and maintenance procedures outlined in this User Guide. If you do have a problem, this section will help you determine what caused it and how to fix it.

**Before you open the side panels of the dryer be sure to:**

Diagnose causes from the control panel.

- 1** Press  once to silence the optional audible alarm and display the alarm message.
- 2** Address the alarm message and fix the problem. (Refer to the alarm descriptions later in this section.)
- 3** Press  again to clear the alarm. If the alarm reappears the problem was not fixed.

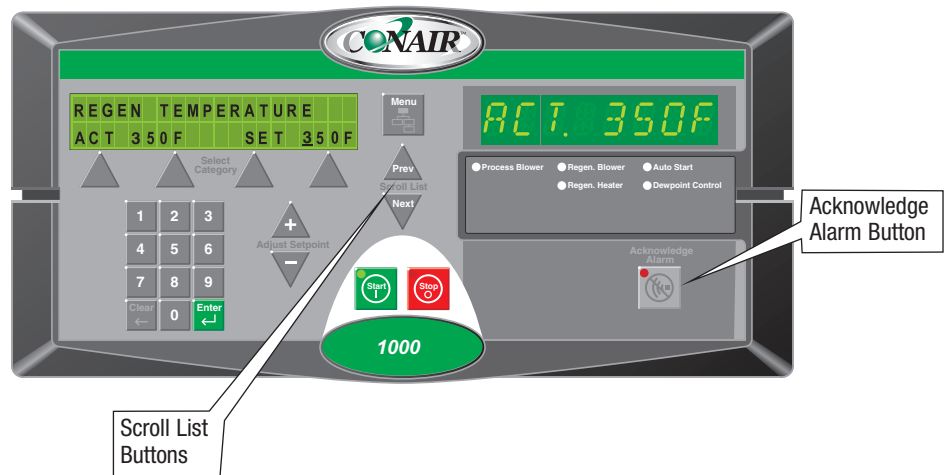

## Before Beginning (continued)

- ❑ **Find the wiring and equipment diagrams that were shipped with your dryer.** These diagrams are the best reference for correcting a problem. The diagrams also will note any custom features, such as special wiring or alarm capabilities, not covered in this User Guide.

See warnings below. Open the electrical enclosure to check fuses and heater contactors.

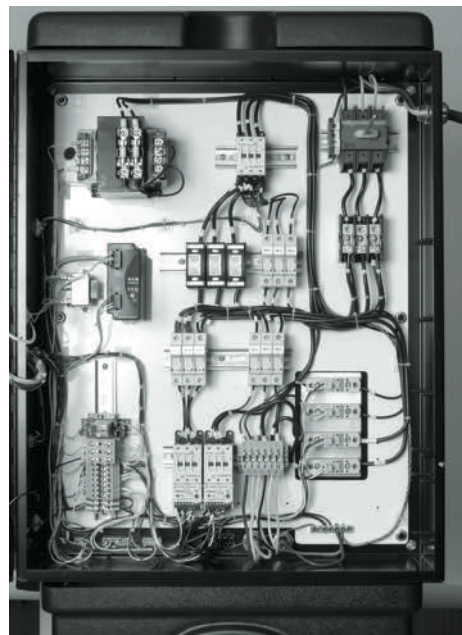

## A Few Words of Caution

The Carousel Plus W Series Dryer is equipped with numerous safety devices. Do not remove or disable them. Improper corrective action can lead to hazardous conditions and should never be attempted to sustain production.

 **WARNING: Only qualified service personnel should examine and correct problems that require opening the dryer's electrical enclosure or using electrical wires to diagnose the cause.**

 **WARNING: High voltage. Always stop the Carousel Plus Dryer, disconnect and lock out the main power source before troubleshooting or performing repairs.**

 **CAUTION: Hot surfaces. Always protect yourself from hot surfaces inside and outside of the dryer and hopper.**

# How to Identify the Cause of a Problem

 **NOTE:** Pushing the Acknowledge Alarm button when there is no active alarm will take the user directly to the Alarm History list (Screen 95, page 4-31).

 **NOTE:** The dryer cannot be started if a passive alarm is present on power-up.

Dryer alarms are indicated by an illuminated Acknowledge Alarm light on the W series dryer control panel.

## A problem can trigger two types of alarms:

- **Shutdown:** The dryer has automatically shut down because it has detected a serious problem that could damage your material or dryer.
- **Passive:** The dryer continues to operate, but warns of a problem that could prevent correct drying of your material. If ignored, this problem could lead to a condition that will shut down the dryer.



When the alarm light is displayed:

- 1 Press the Acknowledge Alarm button once to silence the optional audible alarm and display the alarm message.** Pressing the Acknowledge Alarm button once also changes the alarm LED from blinking to solid.
- 2 Find the error message in the diagnostics table of this *Troubleshooting section*.** Take any necessary steps, as directed, to resolve the problem.
- 3 Note that pressing the Acknowledge Alarm button a second time will clear the alarm.** If the problem was not solved, the alarm will become active again.

There may also be a second alarm condition that occurred as a result of the first alarm.

# Shutdown Alarms

If the red Acknowledge Alarm LED is blinking, the alarm is a shutdown alarm. The dryer will shutdown automatically to prevent damage to the equipment or personnel. Note that once the Acknowledge Alarm button is pressed once, the blinking red LED becomes solid.

 **NOTE:** Some alarms can be set for shutdown or passive (screen 59, page 4-22). These alarms may be listed in both sections.

Problem	Possible cause	Solution
<p><b>Regeneration Heater High Temperature</b> – The snap switch in the regeneration heater tube activated due to excessive temperature.</p>	<p>The regeneration exhaust is blocked or the air hoses are loose.</p>	<p>Locate and remove any airflow restrictions.</p> <p>Tighten any loose hoses.</p>
	<p>The regeneration blower is not running or running in the wrong direction.</p>	<p>Correct the cause of the non-running blower (fuse, etc.) or reverse the rotation of the blower.</p>
	<p>The isolation contactor failed in the closed position.</p>	<p>Replace the isolation contactor.</p>
	<p>The heater solid state relays (SSRs) failed.</p>	<p>Replace the failed heater solid state relays (SSRs).</p>
	<p>The regeneration heater output on the board has failed.</p>	<p>Replace the board.</p>
<p><b>Return Air High Temperature</b> – If the return air temperature at the inlet to the blower is greater than 120°F {49°C}, it shuts down the dryer. (The return air temperature on W1600-5000 dryers is measured at the inlet to the desiccant wheel. <i>W1600-5000 dryers designed prior to August 2007</i>, the return air temperature is measured at the inlet to the process blower.)</p>	<p>The hopper does not contain enough material.</p>	<p>Make sure your material supply system is working properly.</p>
	<p>You are drying at a high drying temperature above 120°F {49°C} or you are running at low throughputs.</p>	<p>Ensure water flow to the aftercooler/intercooler.</p>
	<p>The aftercooler/intercooler does not have enough water.</p>	<p>Turn on the water supply, or fix any leaks or blockages.</p>
<p>The aftercooler/intercooler coils are dirty.</p>	<p>Clean the aftercooler/intercooler coils. <i>See Maintenance section entitled, Cleaning the aftercooler/intercooler coils.</i></p>	

## Shutdown Alarms

If the red Acknowledge Alarm LED is blinking, the alarm is a shutdown alarm. The dryer will shutdown automatically to prevent damage to the equipment or personnel. Note that once the Acknowledge Alarm button is pressed once, the blinking red LED becomes solid.

 **NOTE:** Some alarms can be set for shutdown or passive (screen 59, page 4-22). These alarms may be listed in both sections.

Problem	Possible cause	Solution
<p><b>Regeneration RTD Integrity</b> – If the regeneration RTD is faulty, it shuts down the dryer.</p>	<p>There is a loose connection in the wiring leading to the RTD.</p> <p>The connection of the RTD plug on the control board is loose.</p> <p>The regeneration RTD has failed.</p> <p>The control board has failed.</p>	<p>Check the RTD plug connection and make necessary repairs.</p> <p>Check the plug connection and tighten if needed.</p> <p>Replace the regeneration RTD.</p> <p>Replace the control board.</p>
<p><b>Control Communications Watchdog</b> - The display board has lost communications with the control board.</p>	<p>Plugs on wire harness between the display and control boards are loose or not wired correctly.</p> <p>Display board or communications boards have failed.</p>	<p>Make sure plugs are tight on board connections and match the wiring diagram.</p> <p>Replace the defective boards.</p>
<p><b>Phase Error</b> - One of the three power wires is connected wrong or one or more phases of power is missing.</p>	<p>One of the three power wires are out of phase.</p> <p>A fuse has blown.</p> <p>Phase detection board has failed.</p>	<p>Switch the position of two of the incoming lead power wires at the dryer.</p> <p>Check and replace the fuse.</p> <p>Replace the phase detection board.</p>
<p><b>EEProm Write Error</b></p>	<p>Internal control board problem.</p>	<p>Replace the control board.</p>

# Shutdown Alarms

If the red Acknowledge Alarm LED is blinking, the alarm is a shutdown alarm. The dryer will shutdown automatically to prevent damage to the equipment or personnel. Note that once the Acknowledge Alarm button is pressed once, the blinking red LED becomes solid.

 **NOTE:** Some alarms can be set for shutdown or passive (screen 59, page 4-22). These alarms may be listed in both sections.

## Problem

**Process Blower overload** - If the process blower exceeds its full load amp rating or the overload has tripped due to a mechanical or electrical problem the dryer will shut down.

 **NOTE:** Once the overload has tripped, you must wait 2 to 15 minutes with the power on for the overload to reset automatically.

## Possible cause

The process blower current draw has exceeded the full load amps rating of the motor.

The process blower has mechanically failed or is unable to rotate freely.

The process blower has failed electrically.

Loss of phase of power to the motor starter.

The overload is set incorrectly.

The overload is defective.

## Solution

Press alarm acknowledge and allow the overload to reset then try to restart the dryer. If the alarm condition occurs again have a qualified electrician check the current draw to the motor.

Disconnect and lock out main power. Check the process blower for mechanical failure and free rotation. Replace if necessary. Allow the overload to reset then try to restart the dryer.

Disconnect and lock out main power. Check the process blower for electrical shorts or open circuits. Replace if necessary. Allow the overload to reset then try to restart the dryer.

Check for a blown fuse in the dryer or main power supply. Allow the overload to reset then try to restart the dryer.

Disconnect and lock out main power. Check the overload settings and confirm that the settings match the full load amps listed on the process blower motor. Allow the overload to reset then try to restart the dryer.

Replace the overload.

# Shutdown Alarms

If the red Acknowledge Alarm LED is blinking, the alarm is a shutdown alarm. The dryer will shutdown automatically to prevent damage to the equipment or personnel. Note that once the Acknowledge Alarm button is pressed once, the blinking red LED becomes solid.

 **NOTE:** Some alarms can be set for shutdown or passive (screen 59, page 4-22). These alarms may be listed in both sections.

## Problem

**Regeneration Blower overload** - If the regeneration blower exceeds its full load amp rating or the overload has tripped due to a mechanical or electrical problem the dryer will shut down. The default setting for this alarm is passive but it can be changed to shutdown.

 **NOTE:** This alarm shuts down only the regeneration portion of the dryer. The process blower will continue to run.

 **NOTE:** Once the overload has tripped, you must wait 2 to 15 minutes with the power on for the overload to reset automatically.

## Possible cause

The regeneration blower current draw has exceeded the full load amps rating of the motor.

The regeneration blower has mechanically failed or is unable to rotate freely.

The regeneration blower has failed electrically.

Loss of phase of power to the motor starter.

The overload is set incorrectly.

The overload is defective.

## Solution

Press alarm acknowledge and allow the overload to reset then try to restart the dryer. If the alarm condition occurs again have a qualified electrician check the current draw to the motor.

Disconnect and lock out main power. Check the regeneration blower for mechanical failure and free rotation. Replace if necessary. Allow the overload to reset then try to restart the dryer.

Disconnect and lock out main power. Check the regeneration blower for electrical shorts or open circuits. Replace if necessary. Allow the overload to reset then try to restart the dryer.

Check for a blown fuse in the dryer or main power supply. Allow the overload to reset then try to restart the dryer.

Disconnect and lock out main power. Check the overload settings and confirm that the settings match the full load amps listed on the process blower motor. Allow the overload to reset then try to restart the dryer.

Replace the overload.

# Passive Alarms

If the amber Acknowledge Alarm LED is blinking, the alarm is a passive alarm. The dryer continues to operate, but this problem could prevent correct drying of your material. Note that once the Acknowledge Alarm button is pressed once, the blinking amber LED becomes solid.



**NOTE:** Passive alarms can be configured as shutdown alarms (see the previous Shut Down Alarms section). See page 4-22, screen 59 for instructions.

Problem	Possible cause	Solution
<p><b>Regeneration Temperature Deviation</b> – The regeneration temperature exceeds the deviation band for the specified time. Default values are 10°F {6°C} for 5 seconds.</p>	<p>One of the solid state relays (SSRs) failed.</p> <p>The regeneration RTD is loose or has fallen out.</p> <p>The air hose connections are loose.</p> <p>The output on the board has failed.</p> <p>Defective regeneration heater.</p>	<p>Replace the failed solid state relays (SSRs).</p> <p>Check the regeneration RTD and tighten if needed.</p> <p>Tighten all air hose connections.</p> <p>Replace the board.</p> <p>Check the heater fuses and resistance across each leg of the regeneration heater.</p>
<p><b>Return Air Mid-High Temperature</b> – If the return air temperature is between 150 and 180°F {66 and 82°C}. (The return air temperature on W1600-5000 dryers is measured at the inlet to the desiccant wheel. <i>W1600-5000 dryers designed prior to August 2007, the return air temperature is measured at the inlet to the process blower.</i>)</p>	<p>The hopper does not contain enough material.</p> <p>You are drying at a high drying temperature above 120°F {49°C} or running at low throughputs.</p> <p>The aftercooler/intercooler does not have enough water.</p> <p>The aftercooler/intercooler coils are dirty.</p>	<p>Make sure your material supply system is working properly.</p> <p>Ensure water flow to the aftercooler/intercooler.</p> <p>Turn on the water supply, or fix any leaks or blockages.</p> <p>Clean the aftercooler/intercooler coils. <i>See Maintenance section entitled, <a href="#">Cleaning the aftercooler/intercooler coils.</a></i></p>
<p><b>Regeneration Low Temperature</b> – The regeneration temperature is less than the low temperature setpoint for the specified time. Defaults are 200°F {93°C} for 20 seconds.</p>	<p>The regeneration heater has failed.</p> <p>The output on the control board has failed or the fuse has blown.</p> <p>The regeneration RTD is loose or has fallen out.</p>	<p>Check the heater fuses, and resistance across each leg of the process heater.</p> <p>Replace the control board or the fuse.</p> <p>Check the regeneration RTD and tighten if needed.</p>

# Passive Alarms

If the amber Acknowledge Alarm LED is blinking, the alarm is a passive alarm. The dryer continues to operate, but this problem could prevent correct drying of your material. Note that once the Acknowledge Alarm button is pressed once, the blinking amber LED becomes solid.



**NOTE:** Passive alarms can be configured as shutdown alarms (see the previous Shut Down Alarms section). See page 4-22, screen 59 for instructions.

Problem	Possible cause	Solution
<p><b>Regeneration High Temperature</b> – If the regeneration temperature exceeds the high temperature limit for the specified time. Default values are 400°F {204°C} for 20 seconds.</p>	<p>One of the solid state relays (SSRs) failed in the closed position.</p> <p>The output on the board has failed.</p>	<p>Replace the failed solid state relays (SSRs).</p> <p>Replace the board.</p>
<p><b>Regeneration Temperature Loop Break</b> – The regeneration temperature is outside of the operator entered deviation alarm band (see Regeneration Temperature Deviation passive alarm) and the regeneration temperature is not moving towards the setpoint at a rate greater than specified. Default values are 2°F {1°C} over 40 seconds.</p> <p><b>Process Dewpoint</b> – The dewpoint has not fallen below the setpoint. If the dewpoint goes below the setpoint for 180 seconds the alarm should go away.</p> <p> <b>NOTE:</b> The alarm is not active for the first 5 minutes.</p>	<p>The regeneration heater has failed.</p> <p>The regeneration RTD is loose or has fallen out.</p> <p>The regeneration blower is not running.</p> <p>The output on the control board has failed or the fuse is blown.</p> <p>Defective dewpoint sensor.</p> <p>The hose or wiring connections to the sensor block are loose or have fallen off.</p> <p>Poor regeneration air flow.</p> <p>The desiccant wheel may be contaminated.</p> <p>Desiccant wheel not turning.</p> <p>Leaks in the process air stream.</p> <p>Power Purge blower not running.</p>	<p>Check the heater fuses, and resistance across each leg of the process heater.</p> <p>Check the regeneration RTD and tighten if needed.</p> <p>Check wiring or replace regeneration blower.</p> <p>Replace the control board or fuse.</p> <p>Replace the sensor.</p> <p>Check wiring and hose connections to the sensor, resecure if needed.</p> <p>Remove the air flow restrictions, dirty filters, etc.</p> <p>Check the desiccant for contamination, replace if needed. Install plasticizer / volatile trap for severe situations.</p> <p>Replace the desiccant wheel. <i>See Troubleshooting section entitled, Replacing the desiccant wheel.</i></p> <p><i>See Troubleshooting section entitled, Passive alarms, Wheel rotation alarm.</i></p> <p>Check for worn or loose hoses.</p> <p>Check fuses, wiring or replace blower.</p>

# Passive Alarms

If the amber Acknowledge Alarm LED is blinking, the alarm is a passive alarm. The dryer continues to operate, but this problem could prevent correct drying of your material. Note that once the Acknowledge Alarm button is pressed once, the blinking amber LED becomes solid.



**NOTE:** Passive alarms can be configured as shutdown alarms (see the previous Shut Down Alarms section). See page 4-22, screen 59 for instructions.

Problem	Possible cause	Solution
<p><b>Process Filter Clogged (Option)</b> – The process filter differential pressure switch is tripped.</p>	<p>The process air filter is clogged.</p>	<p>Remove and clean or replace the process air filter.</p>
<p><b>CFM Low (Option)</b> - The CFM calculated from the process blower differential pressure is less than the set-point entered on the operator display.</p>	<p>The air hoses are loose, blocked, or kinked.</p> <p>The return air filter needs cleaned.</p>	<p>Check the process air hose for secure connections, straighten any blocked or kinked hose.</p> <p>Clean and/or change the return air filter.</p>
<p><b>Return Air Temperature RTD Integrity</b> – The dryer continues to run with a passive alarm. (The return air temperature on W1600-5000 dryers is measured at the inlet to the desiccant wheel. <i>W1600-5000 dryers designed prior to August 2007</i>, the return air temperature is measured at the inlet to the process blower.)</p>	<p>There is a loose connection in the wiring leading to the RTD.</p> <p>The connection of the RTD plug on the control board is loose.</p> <p>The return air RTD has failed.</p> <p>The control board has failed.</p>	<p>Check the RTD plug connections and make any necessary repairs.</p> <p>Check the plug connection and tighten if needed.</p> <p>Replace the return air RTD.</p> <p>Replace the control board.</p>
<p><b>Wheel Rotation Failure</b> - The regeneration temperature differential has been reached. The default differential is 20°F / 10 seconds.</p>	<p>The wheel motor is not turning.</p> <p>The belt tensioner is loose or the belt is slipping.</p> <p>The regeneration heater is not working.</p>	<p>Check the motor, plugs, and fuses.</p> <p>Change the tensioner spring or replace the belt.</p> <p>Check the heater fuses and heater.</p>

# Passive Alarms

If the amber Acknowledge Alarm LED is blinking, the alarm is a passive alarm. The dryer continues to operate, but this problem could prevent correct drying of your material. Note that once the Acknowledge Alarm button is pressed once, the blinking amber LED becomes solid.



**NOTE:** Passive alarms can be configured as shutdown alarms (see the previous Shut Down Alarms section). See page 4-22, screen 59 for instructions.

Problem	Possible cause	Solution
<p><b>Regeneration Outlet RTD Integrity</b> - The control can not sense the regeneration outlet RTD.</p>	<p>There is a loose connection in the wiring leading to the RTD.</p> <p>The connection of the RTD plug on the control board is loose.</p> <p>The regeneration outlet RTD has failed.</p> <p>The control board has failed.</p>	<p>Check the RTD plug connection and make any necessary repairs.</p> <p>Check the plug connection and tighten if needed.</p> <p>Replace the regeneration outlet RTD.</p> <p>Replace the control board.</p>
<p><b>Dewpoint Deviation High</b> - Displayed when the actual dewpoint goes above the setpoint by a specified amount of time and degrees. Defaults are set for 5°F {3°C} for 30 seconds.</p>	<p>Desiccant wheel not turning.</p> <p>The hose or wiring connections to the sensor block are loose or have fallen off.</p> <p>Poor regeneration air flow.</p> <p>The desiccant wheel may be contaminated.</p> <p>Leaks in the process air stream.</p>	<p><i>See Troubleshooting section entitled, Passive alarms, Wheel rotation alarm.</i></p> <p>Check wiring and hose connections to the sensor, resecure if needed.</p> <p>Remove the air flow restrictions, dirty filters, etc.</p> <p>Check the desiccant wheel for contamination, replace if needed. <i>See Troubleshooting section entitled, Replacing the desiccant wheel assembly.</i></p> <p>Check for worn or loose hoses.</p>
<p><b>Dewpoint Deviation Low</b> - Displayed when the actual dewpoint goes below the setpoint by a specified amount of time and degrees. Defaults are set for 5°F {3°C} for 30 seconds.</p>	<p>The dewpoint can not control to the desired setpoint.</p> <p>The dewpoint sensor has failed.</p>	<p>Install plasticizer/volatile trap for severe situations.</p> <p>Material and/or ambient condition may be too dry to increase the actual dewpoint. Please wait several hours to determine if the setpoint can be reached. Increase the dewpoint low deviation value.</p> <p>Replace the dewpoint sensor.</p>

# Additional Alarms

Along with the alarm indicators, you may encounter additional messages that indicate a problem within the control.

Problem	Possible cause	Solution
<b>Control Not Ready, Please Check Alarm</b> - Displayed when the “Start” button is pushed during any active alarm. (Passive or Shutdown)	The dryer will continue to run if there is a passive alarm, however it will not start if there is a active alarm.	Push the acknowledgement button to identify the alarm, and address it as necessary.
<b>Lost Comm w/ Ctrl Bd</b> - Indicates there is a problem in the communication between the control board and the display board.	Loose or improperly connected wire.	Check wiring between control board and display board.
	Improper dip switch setup on control board.	Check dip switch setup on control board.
	Defective display or control board.	Replace boards as a set.
<b>Error ! Incorrect Firm Version</b> - Indicates a mismatch of software between the display board and the control board.	The software revision of the display board and control board are not compatible.	In most cases, both display and control boards will need to be replace as a set.

# Additional Alarms

Along with the alarm indicators, you may encounter additional messages that indicate a problem within the control.

Problem	Possible cause	Solution
<p><b>Er. Lo</b> - There is a problem in the sensor connection (RTD, Dewpoint sensor, etc.) for the effected function.</p>	<p>Problem in the analog input section of the control.</p>	<p>Check that all jumpers are in their proper place.</p> <p>Check to see if the dewpoint sensor is connected properly.</p> <p>Disconnect the ribbon cable connecting any analog option boards to the main control board. If the display returns to normal for all values except those that are generated through the analog options boards, replace the option board.</p>
	<p>Defect in the main control board.</p>	<p>Replace main control board.</p>
<p><b>Er. Hi</b> - There is a problem in the analog input section of the control.</p>	<p>RTD is not connected properly or is defective.</p>	<p>Check RTD connections.</p>
	<p>Replace defective RTD.</p>	
	<p>The ribbon cable between an analog option board and the main control board is not connected properly.</p>	<p>Check connections between analog option board and the main control board.</p>
	<p>Connector to all RTDs is removed.</p>	<p>Disconnect the ribbon cable connecting any analog option boards to the main control board. If the display returns to normal for all values except those that are generated through the analog options boards, replace the option board.</p>
	<p>Problem in the analog input section of the control.</p>	<p>Disconnect the ribbon cable connecting any analog option boards to the main control board. If the display returns to normal for all values except those that are generated through the analog options boards, replace the option board.</p>
<p>Defect in the main control board.</p>	<p>Replace main control board.</p>	

# Dewpoint Troubleshooting

Under normal operating conditions, the dryer will produce dewpoints in the range of -40 to -20° F {-40 to -29° C}. However, you may experience situations that produce undesirable results.

## Problem

Dryer not producing desired dewpoint.

## Possible cause

Low regeneration air flow.

Return air temperature exceeds 125°F {52°C}.

Regeneration temperature is below normal setting.

Leaks in process lines.

Contaminated desiccant due to off-gassing, too long of a residence time or drying temperature is too high for the grade of material being processed.

Analog option board/sensor malfunction

## Solution

Check regeneration filter and clean and/or replace as necessary.

Reduce the temperature of the cooling water or increase the flow.

Connect water to the aftercooler/intercooler if not already connected.

Check for adequate water temperature. Water temperature should be approximately 85°F {29°C}.

Check amperage of regeneration heaters. Replace heaters if necessary.



**WARNING:** Any electrical checks should be performed by a qualified electrician.

Check all hoses, gaskets, doors, loaders or other potential areas where leakage may occur. Replace any defective hoses or gaskets.

Verify proper drying temperatures and residence times. If off-gassing is a condition of the material being processed, contact Conair Parts at (800) 458 1960 for the addition of a volatile trap.

Verify dryer dewpoint readings with a calibrated portable dewpoint meter.

Replace analog option board or sensor.

# Poor Material Drying Troubleshooting

Occasionally, processing problems that are suspected of being caused by poor drying are eventually determined to be the result of other issues in the process setup. The intent of the information provided here is to assist you in determining if your drying system is performing properly. However, the only way to know definitely if your material is properly dried is to perform moisture analysis of small samples as it leaves the bottom of the hopper, or just as it enters the process. Conair does not sell moisture-analyzing equipment, but there are many brands of this equipment available on the market.



**NOTE:** Concerns with drying temperature may require review of HTC or ResinWorks controls.

You should also be aware that some processing problems may actually be the result of over-drying material. Most materials will degrade to some extent if they are exposed to their specified drying temperature for a time significantly longer than the residence time specified by the supplier. If you want to maintain its dryness, it is recommended that you reduce the process air temperature. If your Conair dryer is equipped with the Setback feature, you should familiarize yourself with it, and make use of it. If not, you may want to contact Conair to determine if it can be added to your dryer.

A majority of customer questions to Conair are related to dewpoint. It is important to realize that dewpoint is one of **four** requirements that need to be satisfied.

**There are four requirements, listed in order of importance, necessary to properly dry hygroscopic plastic resins:**

- 1** **Drying temperature** of the air entering the hopper must be at the proper drying temperature for your material, as specified by your material supplier.
- 2** **Residence time** is the time, determined by your material supplier, that the material in use must be heated to achieve proper drying temperature.
- 3** **Airflow** during the process drying circuit must be adequate to carry and distribute the heat throughout the entire bed of material inside the hopper.
- 4** **Dewpoint** of the process air must be low so it can efficiently collect the moisture as it is released from the heated material and carry it to the dryer to be removed in the desiccant.

# Poor Material Drying Troubleshooting (continued)

Once it is determined which of the four requirements that is not being satisfied, refer to the following list of possible causes and solutions.

 **NOTE:** Concerns with drying temperature may require review of HTC or ResinWorks controls.

**Temperature** - The temperature of the air entering the hopper must be at the proper drying temperature for your material, as specified by your supplier.

Problem	Possible cause	Solution
<b>The temperature of the air entering the hopper is not at proper drying temperature.</b>	Incorrect setpoint	Refer to the drying specifications for your material and adjust the setpoint to the recommended setpoint.  If your dryer has the Setback option, make sure it is not active unless you have specifically activated it. If necessary, refer to the Operation section of this manual for assistance in using the Setback function.
	Not able to achieve setpoint.	Replace any defective process heater, contactors, fuses, etc.  Ensure the selected drying temperature is within the design specifications of your dryer.
	Inaccurate process temperature readout.	Ensure the Process RTD is properly positioned in the air stream.  Determine if there is a problem in the temperature control circuit and repair or replace any defective components such as RTD, temperature control, circuit boards, etc.

# Poor Material Drying Troubleshooting (continued)

**Residence Time** - The time your material supplier has determined that the material in use must be heated to its drying temperature to achieve proper drying.

<b>Problem</b>	<b>Possible cause</b>	<b>Solution</b>
<b>Material residence time is too long or short.</b>	Material level in hopper is too low.	Make sure there is an adequate supply of material to feed the loader on top of the drying hopper.  Correct any problems with the conveying system that may be preventing your loader from filling the hopper.  If your hopper has a level sensor for maintaining a material level less than completely full, be sure this sensor is adjusted properly.
	Material throughput is too high.	Take any necessary steps, such as slowing down the process, to ensure the material usage is within design specifications of the dryer and hopper.

# Poor Material Drying Troubleshooting (continued)

**Airflow** - The airflow in the process drying circuit must be adequate to carry and distribute the heat throughout the entire bed of material inside the hopper. If the airflow is too low, the material in the center of the hopper may get heated fully to the drying temperature, but the material against the sidewalls will not. In most cases, the material 2/3 to 3/4 of the way toward the top of the hopper should be heated to the proper drying temperature.

## Problem

**Too much or too little airflow.**



**NOTE:** If there is too much airflow, the material may fluidize inside the hopper, resulting in inconsistent material flow through the hopper, which can negatively impact residence time.

## Possible cause

Dirty process air filter.

Collapsed hoses or holes/leaks in the hoses and hose connection.

Airflow restrictions.

Process blower running backwards or performing poorly.

Material level in the hopper too low.

## Solution

Clean or replace the process filter.

Replace any worn or damaged hoses. Tighten all hose clamps to eliminate leaks.

Remove any obstructions in the process air circuit.

Verify the process blower is running in the correct direction. If backwards, reverse direction by switching any 2 legs of high voltage to the motor.



**WARNING:** Any electrical checks should be performed by a qualified electrician.

Repair or replace motor.

Other than running out of material to complete a job, the material level inside the hopper must be a minimum of 50% full. If the hopper is not at least half full, the material in the cone section will not get adequate airflow to dry properly.

Replacement dewpoint monitors are available from Conair.

Contact Conair Parts  
(800) 458 1960  
From outside of the  
United States, call:  
(814) 437 6861

## Poor Material Drying Troubleshooting (continued)

**Dewpoint** - The process air must be at a low dewpoint so it can efficiently collect the moisture as it is released from the heated material and carry it to the dryer to be removed in the desiccant. In most cases, the dryer will dry your material satisfactorily if the dewpoint of the air is -20 to -40° F {-29 to -40° C}. If your dryer does not have a dewpoint readout, you can check the dewpoint with a portable dewpoint instrument. Conair sells a variety of portable dewpoint meters. Contact Conair

### Problem

Dryer dewpoint is not reaching proper setpoint.

### Possible cause

Low regeneration temperature.

Poor regeneration airflow.

High dewpoint, ambient air leaking into the closed loop drying circuit.

Return air temperature to the dryer is too high. (The return air temperature on W1600-5000 dryers is measured at the inlet to the desiccant wheel. *W1600-5000 dryers designed prior to August 2007*, the return air temperature is measured at the inlet to the process blower.)

Poor desiccant performance.

### Solution

Replace or check defective heaters, fuses etc.

Clean or replace the regeneration filter.

Ensure the regeneration blower is operating properly and rotating in the correct direction. *See Installation section entitled, Checking for proper airflow.*

Remove obstructions in the air stream, such as crimped hoses, etc.

Replace damaged hoses and seal any leaks in the process air circuit.

If using a vacuum loader on the hopper, ensure that the loader shroud is installed in the hopper and that the hopper is completely filled with material.

If partially filling your hopper, ensure that the hopper loader is sealed against ambient air.

Install a gasket between the loader and the top of the hopper.

Clean the aftercooler/intercooler coils. *See Maintenance section entitled, Cleaning the aftercooler/intercooler coils.*

*See Troubleshooting section entitled, Replacing the desiccant wheel assembly.*

# Replacing Fuses

- 1 Disconnect and lockout the main power supply.** 
- 2 Open the electrical enclosure door.**
- 3 Check the fuse with an ohmmeter.** If necessary, pull the fuse out and replace it with a fuse of the same type and rating.

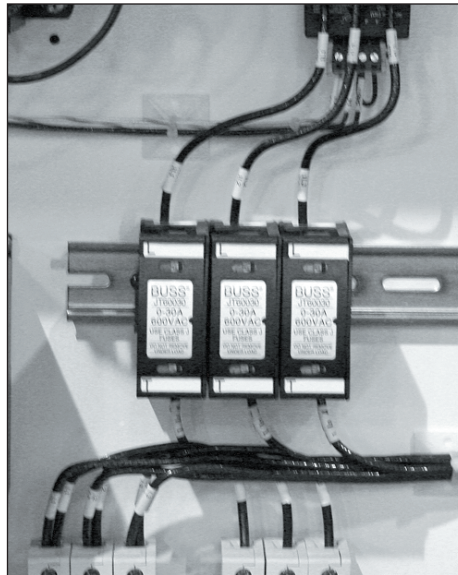
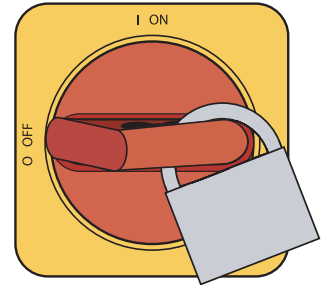

## Fuse Blocks

To locate the appropriate fuse and replacement part, refer to the wiring diagrams that came with your dryer.



**IMPORTANT:** Always refer to the wiring diagrams that came with your dryer to locate specific electrical components. Illustrations in the User Guide are intended to be representative only.

# Checking Heater Solid State Relays

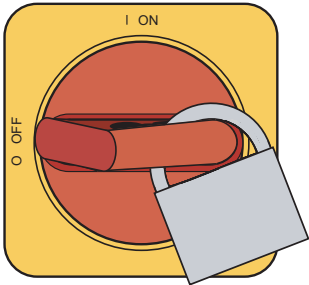

**IMPORTANT:** Always refer to the wiring diagrams that came with your dryer to locate specific electrical components. Illustrations in the User Guide are intended to be representative only.



**NOTE:** Measure voltage using a voltmeter across the two high voltage connections of each relay. (Shown here circled in red.)



**CAUTION:** Always disconnect and lock out the main power sources before making electrical connections. Electrical connections should be made only by qualified personnel.

**1**

**Disconnect and lockout the main power supply.**

**2 Open the electrical enclosure.**

**3 Locate the regeneration solid state relays. Refer to the wiring diagrams that came with your dryer.**

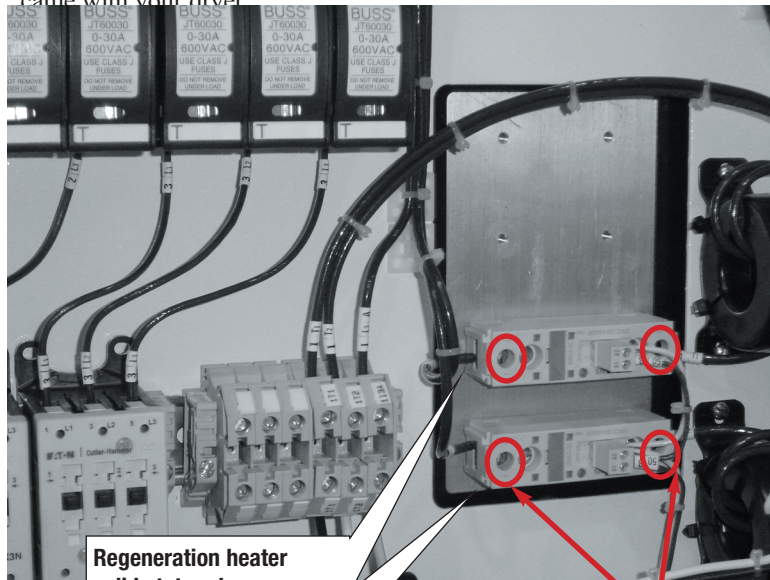

Regeneration heater  
solid state relays

**4 Turn power on to the machine.**

**5 Start the dryer.**

**6 Measure voltage across the high voltage connections using a voltmeter.** When relay is energized, as indicated by the LED (green) voltage should be read 0 (zero). When relay is de-energized, LED off, full voltage should be measured across the relay. When relay is off, if voltage reads zero, relay is bad and needs replaced. Repeat this procedure for each relay.

# Checking or Replacing Temperature Sensors

The Carousel Plus W Series Dryer uses RTD sensors to monitor the temperatures of the return air, the regeneration outlet, and the regeneration inlet.

To check or replace an RTD sensors:

- 1 Disconnect and lockout the main power supply.** 
- 2 Remove dryer panels, as necessary.** *See Installation section entitled, Opening the dryer doors (W1600-5000).*
- 3 Locate the RTD sensors.**
- 4 Check the sensor positions and conditions.** Temperature readings will be incorrect, if the sensors are touching the wall of an air hose or pipe or if the sensor or wiring is damaged. The tip of the sensor should be centered within the air hose or pipe. Sensor wires should be attached to the appropriate connection points on the dryer's electrical enclosure or microprocessor board.
- 5 To check with ohm meter,** measure the resistance across the RTDs. The resistance should be approximately 110 ohm at room temperature.
- 6 Replace the sensor, if necessary.**



**IMPORTANT:** Always refer to the wiring diagrams that came with your dryer to locate specific electrical components. Illustrations in the User Guide are intended to be representative only.

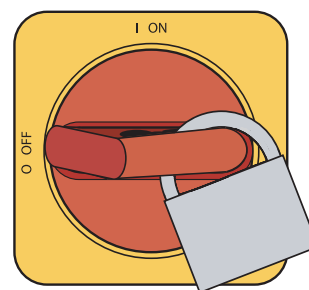

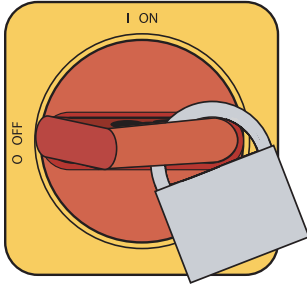

# Replacing the Regeneration Heater

(W600 - 1000)



**IMPORTANT:** Always refer to the wiring diagrams that came with your dryer to locate specific electrical components. Illustrations in the User Guide are intended to be representative only.

- 1 Stop the dryer, disconnect the power, and follow proper lockout procedures.** 
- 2 Remove the right side panel of the dryer, as viewed from the front of the dryer, to gain access to the regeneration heater.** 
- 3 Disconnect the regeneration heater power wires from the terminal block in the control cabinet.** Feed the regeneration power cable out of the control cabinet.



Clamp  
Regeneration Heater  
Clamp

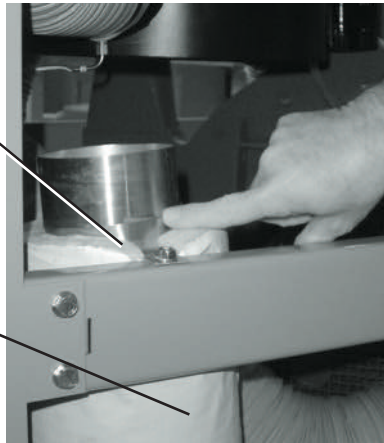

Clamp  
Insulation

- 4 Unplug the quick disconnect for the high temperature switch cable at the switch.**
- 5 Loosen the hose clamps then remove the hoses from the top and bottom of the regeneration heater tube.** Remove and check the bottom heater hose for loose debris or fragments, these fragments can damage the newly installed heater if not removed.
- 6 While supporting the heater tube, loosen the hose clamp supporting the regeneration tube to the mounting bracket, then remove the heater tube from the dryer.**
- 7 Slide the insulation off the heater tube, or make a cut the entire length of the insulation sleeve to aid removal.**

# Replacing the Regeneration Heater



(W600 - 1000) (continued)

- 8** Compare the markings on the outside of the regeneration heater tube to ensure the new one has the same voltage and kW ratings as the original heater tube. This information is on the end nearest the wires.
- 9** Slide the original insulation over the new heater or, if the insulation was cut for removal, wrap the cut insulation sleeve around the new heater tube and secure it with duct tape.
- 10** Make sure the cable end of the heater tube is to the bottom then secure the new heater tube to the mounting bracket with a hose clamp.
- 11** Connect the hoses to the top and bottom of the heater tube and secure them with hose clamps.
- 12** Connect the high temperature switch wires to the quick disconnects near the heater tube.
- 13** Route the heater power cable into the control cabinet and connect the leads to the original locations on the terminal block. Refer to the wiring diagram for specific connection information.
- 14** Replace the side panel of the dryer.
- 15** Measure the resistance from each leg of the heater tube to the others and from each leg to ground. There should be +/- 5% resistance variation between all 3 legs, and high resistance from each leg to ground.
- 16** Connect the dryer to power and turn it on. Verify that the regeneration temperature achieves the setpoint.

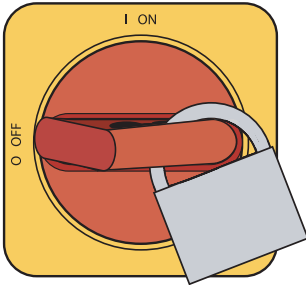
# Replacing the Regeneration Heater (W1600 - 2400)



**IMPORTANT:** Always refer to the wiring diagrams that came with your dryer to locate specific electrical components. Illustrations in the User Guide are intended to be representative only.

- 1 Stop the dryer, disconnect and lockout the main power.** 
- 2 Locate the heater.** Open the side panels of the dryer locating the heater which is secured to the inlet of the desiccant wheel assembly by hard piping, brackets and clamps.  *See Installation section entitled, Opening the dryer doors (W1600-5000).*

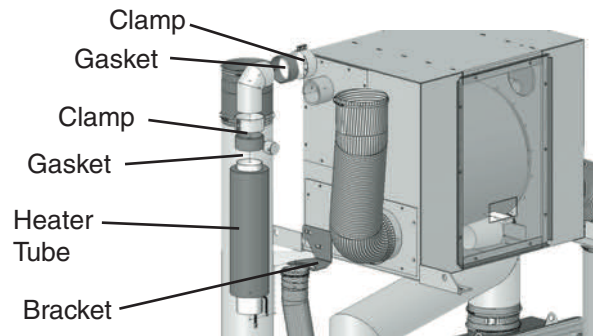

- 3 Disconnect the main power leads at the junction box inside the frame of the dryer.**
- 4 Disconnect the high temperature switch cable at the quick disconnect.**
- 5 To remove the defective regeneration heater tube, loosen the pressure clamps at the top and bottom of the heater tube connection and slide the clamp and its silicon gasket back away from the heater tube. W1600-2400 model dryers lower clamp is attached to a bracket that is mounted to the desiccant wheel assembly, loosen clamp to remove it from the bracket.** Remove and check the bottom heater hose for loose debris or fragments, these fragments can damage the newly installed heater if not removed.
- 6 Slide the insulation off the heater tube, or make a cut down the entire length of the insulation sleeve to aid removal.**
- 7 Compare the markings on the outside of the regeneration heater tube to ensure the new one has the same voltage and kW ratings as the original heater tube.** This information is on the end nearest the wires.

# Replacing the Regeneration Heater

(W1600 - 2400) (continued)

- 8** Slide the original insulation over the new heater, or if the insulation was cut for removal, wrap the cut insulation sleeve around the new heater tube and secure it with heat tape.
- 9** Make sure the cable end of the new heater tube is to the bottom, then connect the hoses to the top and bottom of the heater tube and resecure with pressure clamps and the lower heater tube bracket that was removed in Step 5.
- 10** Connect the high temperature switch cable to the quick disconnect.
- 11** Route the heater power wires into the junction box, and connect them to the supply leads from the control box. Refer to the wiring diagram for specific connection information.
- 12** To ensure all connections are correct, measure the resistance as in Step 3. You should measure the readings as noted for a good heater.
- 13** Close the side panel of the dryer.
- 14** Connect the dryer to power and turn it on. Verify the regeneration temperature achieves the setpoint.

# Replacing the Regeneration Heater (W3200 - 5000)

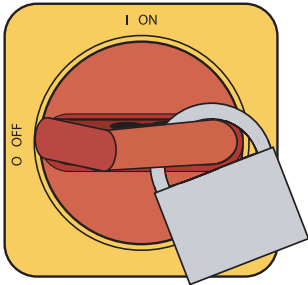

**IMPORTANT:** Always refer to the wiring diagrams that came with your dryer to locate specific electrical components. Illustrations in the User Guide are intended to be representative only.

- 1 Stop the dryer, disconnect and lockout the main power.**
- 2 Locate the heater(s).** Open the side panels of the dryer locating the heaters which are secured to the inlet of the desiccant wheel assembly by hard piping, a heater tube manifold, brackets and clamps. *See Installation section entitled, Opening the dryer doors (W1600-5000).*

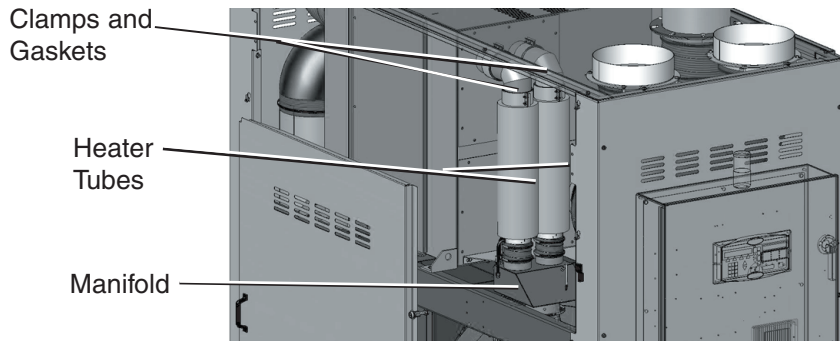

- 3 Disconnect the main power leads at the junction box inside the frame of the dryer.** In units with two heaters (W3200 and W5000), it may be necessary to measure resistance across the power leads of each heater tube to determine which heater needs to be replaced. In a good element, the resistance across all three legs should be +/- 5% resistance variation when measured leg-to-leg, and high resistance from each leg to ground. Readings other than this indicate a defective heater.
- 4 Disconnect the high temperature switch cables at the quick disconnects.**
- 5 Loosen the pressure clamps at the top and bottom of the heater tube connection and slide the clamp and its silicon gasket back and away from the heater tube to remove the defective regeneration heater tube(s).** W3200-5000 model dryers lower heater clamp(s) are attached to a manifold that is secured to the desiccant wheel assembly with a bracket, loosen the clamp that secures the heater tube to the manifold to remove it from the dryer.

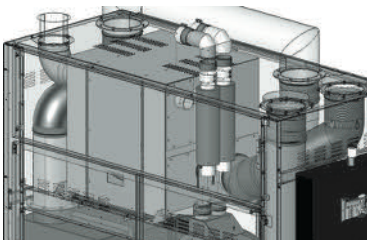

# Replacing the Regeneration Heater

(W3200 - 5000) (continued)

- 6** Loosen the two (2) lower clamps that secure the regeneration manifold and tubing to the desiccant wheel bracket. Remove the regeneration manifold and the tubing that is attached to the bottom of the manifold. Then remove the tubing from the regeneration blower outlet and check for loose particles within the tubing, clean as necessary. Reverse this procedure to reinstall the regeneration manifold and tubing.
- 7** Slide the insulation off the heater tube(s), or make a cut down the entire length of the insulation sleeve to aid removal.
- 8** Compare the markings on the outside of the regeneration heater tube to ensure the new one has the same voltage and kW ratings as the original heater tube. This information is on the end nearest the wires.
- 9** Slide the original insulation over the new heater, or if the insulation was cut for removal, wrap the cut insulation sleeve around the new heater tube and secure it with heat tape.
- 10** Make sure the cable end of the new heater tube is to the bottom, then reconnect the hoses to the top and bottom of the heater tube and resecure with pressure clamps that were removed in Step 5.
- 11** Connect the high temperature switch cable to the quick disconnect.
- 12** Route the heater power wires into the junction box and connect them to the supply leads from the control box. Refer to the wiring diagram for specific connection information.
- 13** To ensure all connections are correct, measure the resistance as in Step 3. You should measure the readings as noted for a good heater.
- 14** Close the side panel of the dryer.
- 15** Connect the dryer to power and turn it on. Verify the regeneration temperature achieves the setpoint.

# Replacing the Desiccant Wheel Assembly (W600 - 1000)

When desiccant becomes clogged or contaminated, you should replace the desiccant wheel to ensure optimum performance.

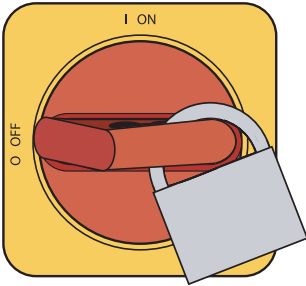

**1** Stop the dryer, disconnect the power, and follow proper lockout procedures.



**2** Remove the upper and lower side panels from both sides of the dryer.



**3** Remove the top cover from the dryer by removing the securing bolts.

**4** Note the position of all the hoses, RTDs, and wiring connections then remove or disconnect these from the desiccant wheel assembly.

**5** If the dryer aftercooler is being used, turn off the water supply to the aftercooler and disconnect the water lines from the aftercooler.

**6** Remove the bolts securing the aftercooler assembly to the desiccant wheel assembly.

**7** Remove the bolts securing the desiccant wheel assembly in the dryer frame.



**8** If the dryer aftercooler is being used, slide the desiccant wheel assembly towards the front of the dryer, being careful not to let it fall off the dryer frame. Unbolt the aftercooler assembly from the back panel of the dryer and remove it.

**9** Note the orientation of the desiccant wheel assembly. Using an overhead crane or similar device, use the lifting rings provided and lift the desiccant wheel assembly out of the dryer.



(continued)



# Replacing the Desiccant Wheel Assembly (W600 - 1000) (continued)

- 10** Lift the new desiccant wheel into the dryer frame, being sure it is oriented properly. To verify the correct orientation, ensure that the regeneration air inlet is positioned closest to the regeneration heater tube. **DO NOT** bolt into place at this time.
- 11** If the dryer aftercooler is being used, **slide the desiccant wheel assembly towards the front of the dryer, being careful to not let it slip off one side of the dryer frame.** Position the aftercooler assembly into the dryer frame and bolt it to the rear panel.
- 12** Position the desiccant wheel assembly and bolt it in place.
- 13** Bolt the aftercooler to the desiccant wheel assembly.
- 14** If the aftercooler is being used, reconnect the water lines.
- 15** Reconnect or reinstall all hoses, RTDs, and wiring connections.
- 16** Bolt the top cover in place.
- 17** Connect the power to the dryer and start it. Ensure that the desiccant wheel assembly rotates in the correct direction.
- 18** Replace all upper and lower side panels.

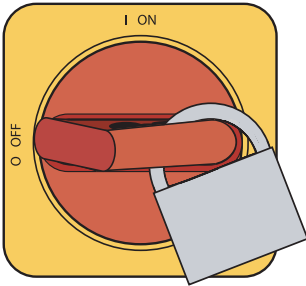

# Replacing the Desiccant Wheel Motor (w600 - 1000)



- 1** Stop the dryer, disconnect and lockout the main power. 
- 2** Remove both side panels. 
- 3** Disconnect wiring to the motor.
- 4** Remove the pivot bolt securing the belt tensioner to the motor bracket. Be sure to retain the flat washers located between the tensioner and bracket. Disconnect the spring and remove the tensioner.
- 5** Remove the belt from the motor pulley, then remove the pulley from the motor.
- 6** Remove the screws securing the motor to the upper and lower bracket, and remove the motor.
- 7** Secure the new motor to the bracket.
- 8** Install the pulley on the new motor, and position the belt on the pulley.
- 9** Connect the spring to the tensioner, then secure the tensioner to the motor bracket. Be sure to install flat washers between the motor bracket and the tensioner.
- 10** Connect the wires to the motor.
- 11** Connect the power to the dryer. Turn the dryer on and ensure that the desiccant wheel is rotating in the correct direction.
- 12** Replace the side panels.

# Replacing the Desiccant Wheel Motor (W1600 - 5000)

**1** Stop the dryer, disconnect and lockout the main power. 

**2** Open the right side panel(s), as viewed from the front of the dryer. 

*See Installation section entitled, Opening the dryer doors (W1600-5000).*

**3** Unbolt and remove the access panel on the side of the desiccant wheel assembly.

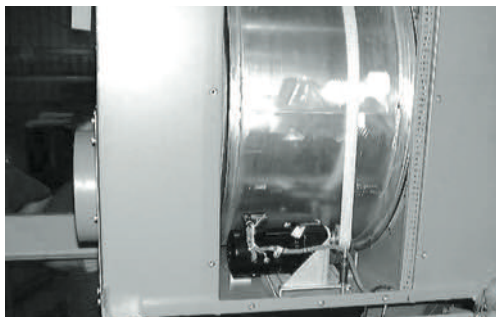

**4** Disconnect the wiring connection to the motor.

**5** While noting the number of turns, relieve the tension on the drive bolt by loosening the nut above the tension spring until the belt can be slipped off the motor sprocket.

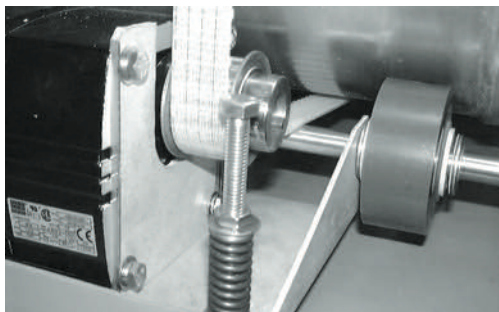

**6** Unbolt the motor and remove it from its mounting bracket.

**7** Remove the sprocket from the old motor, and install it onto the new motor.

**8** Bolt the new motor in place. Be sure to remove the plastic plug in the vent hole of the gearbox.

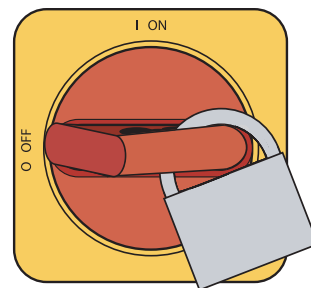

(continued)

# Replacing the Desiccant Wheel Motor (W1600 - 5000) (continued)

- 9** Slip the belt onto the sprocket, and adjust the tension spring nut to its original position.
- 10** Connect the wires to the new motor.
- 11** With the access panel still removed, connect the power to the dryer and start it. Ensure the wheel turns in the correct direction. If the belt appears to be slipping, it may be necessary to increase the tension on the drive belt slightly. Do not increase this tension any more than necessary to allow the wheel to rotate without slipping.
- 12** Bolt the access panel in place and close the side panel(s) on the dryer.

## We're Here to Help

Conair has made the largest investment in customer support in the plastics industry. Our service experts are available to help with any problem you might have installing and operating your equipment. Your Conair sales representative also can help analyze the nature of your problem, assuring that it did not result from misapplication or improper use.

Additional manuals and prints for your Conair equipment may be ordered through the Customer Service or Parts Department for a nominal fee. Most manuals can be downloaded free of charge from the product section of the Conair website.  
[www.conairgroup.com](http://www.conairgroup.com)

## How to Contact Customer Service

To contact Customer Service personnel, call:



**NOTE:** Normal operating hours are 8:00 am - 5:00 pm (EST). After hours emergency service is available at the same phone number.

You can commission Conair service personnel to provide on-site service by contacting the Customer Service Department.

## Before You Call...

If you do have a problem, please complete the following checklist before calling Conair:

- Make sure you have all model, control type and serial numbers from the serial tag, and parts list numbers for your particular equipment. Service personnel will need this information to assist you..
- Make sure power is supplied to the equipment.
- Make sure that all connectors and wires within and between control systems and related components have been installed correctly.
- Check the troubleshooting guide of this manual for a solution.
- Thoroughly examine the instruction manual(s) for associated equipment, especially controls. Each manual may have its own troubleshooting guide to help you.
- Check that the equipment has been operated as described in this manual.

## Equipment Guarantee

Conair guarantees the machinery and equipment on this order, for a period as defined in the quotation from date of shipment, against defects in material and workmanship under the normal use and service for which it was recommended (except for parts that are typically replaced after normal usage, such as filters, liner plates, etc.). Conair's guarantee is limited to replacing, at our option, the part or parts determined by us to be defective after examination. The customer assumes the cost of transportation of the part or parts to and from the factory.

## Performance Warranty

Conair warrants that this equipment will perform at or above the ratings stated in specific quotations covering the equipment or as detailed in engineering specifications, provided the equipment is applied, installed, operated and maintained in the recommended manner as outlined in our quotation or specifications.

Should performance not meet warranted levels, Conair at its discretion will exercise one of the following options:

- Inspect the equipment and perform alterations or adjustments to satisfy performance claims. (Charges for such inspections and corrections will be waived unless failure to meet warranty is due to misapplication, improper installation, poor maintenance practices or improper operation.)
- Replace the original equipment with other Conair equipment that will meet original performance claims at no extra cost to the customer.
- Refund the invoiced cost to the customer. Credit is subject to prior notice by the customer at which time a Return Goods Authorization Number (RGA) will be issued by Conair's Service Department. Returned equipment must be well crated and in proper operating condition, including all parts. Returns must be prepaid.

Purchaser must notify Conair in writing of any claim and provide a customer receipt and other evidence that a claim is being made.

## Warranty Limitations

**Except for the Equipment Guarantee and Performance Warranty stated above, Conair disclaims all other warranties with respect to the equipment, express or implied, arising by operation of law, course of dealing, usage of trade or otherwise, including but not limited to the implied warranties of merchantability and fitness for a particular purpose.**

# Cleaning the Precooler Coils

You need to clean the precooler coils to keep them working efficiently. Cleaning frequency depends on the type and amount of material you process.

**1 Stop the dryer and lockout the main power.**



**2 Turn off the water flow to the water supply line.** Disconnect supply and return lines.

 **NOTE:** If an optional flow control was added with the precooler, remove the compression fitting from the precooler inlet. Loosen the fitting on the flow control, then swing the copper water supply tube out and away from the precooler inlet.

**3 Remove the bolts securing the precooler cover.** Remove the cover.

**4 Remove the precooler by pulling it out** of the precooler housing.

**5 Clean the assembly using a mild soap and water.** Let the assembly dry thoroughly before installation.

 **NOTE:** In cases of heavy volatiles, steam cleaning or the use of solvents, such as acetone, may be necessary. Be sure to test a small area with the solvent you have selected to be sure there is no adverse reaction.

**6 Inspect the condition of the gasket.** If it is damaged, replace the gasket.

**7 Reassemble** by repeating the steps in reverse order.

**8 Connect the water supply line to the inlet.** If a manual shut off valve is used, it should be mounted on the inlet line as well.

**9 Connect the outlet of the precooler to the inlet of the flow control valve** using the pre-shaped copper tubing and compression fittings provided.

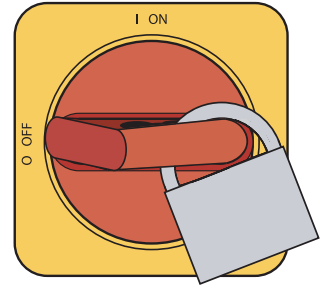

# Cleaning the Volatile Trap on the Demister (W600 - 1000)

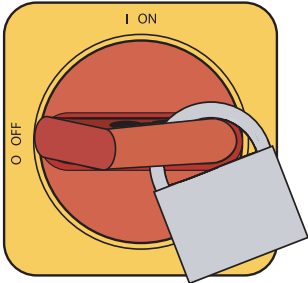

- 1 Stop the dryer and lockout the main power.** 
- 2 Remove the thumbscrews then remove the volatile demister cover.**
- 3 Remove the demister by pulling it out from the housing.**



- 4 Clean the assembly using a mild soap and water.** Let the assembly dry thoroughly before installation.



**NOTE:** In cases of heavy volatiles, steam cleaning or the use of solvents, such as acetone, may be necessary. Be sure to test a small area with the solvent you have selected to be sure there is no adverse reaction.



- 5 Insert the demister carefully back into the housing, making sure to completely push it towards the back of its housing.**
- 6 Inspect the condition of the gasket.** If it is damaged, replace the gasket.
- 7 Secure the cover in place using the original thumbscrews.** Make sure the cable is not pinched between the housing and the cover.

# Cleaning the Volatile Trap on the Demister (W1600 - 5000)

**1** Stop the dryer and lockout the main power. 

**2** Remove the thumbscrews then remove the volatile demister carriage and demister from its housing.

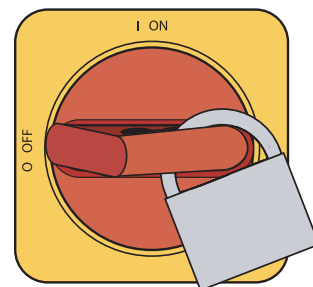
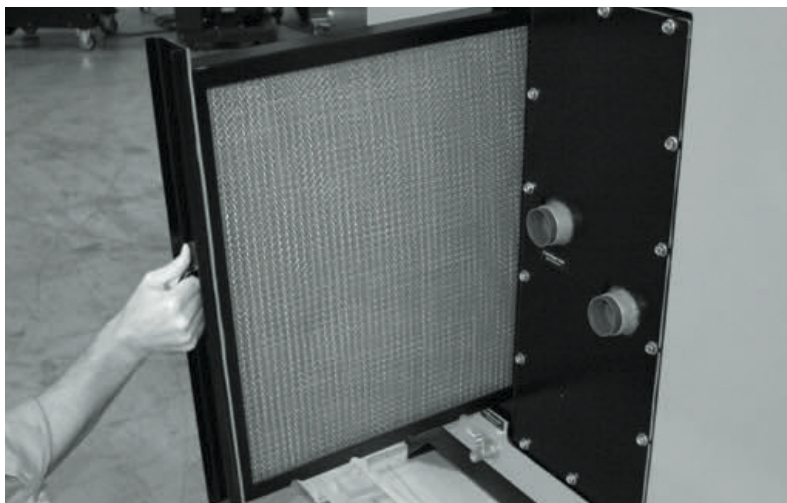

**3** Remove the demister from the demister carriage by pushing it out towards the right side of the carriage.

**4** Clean the assembly using a mild soap and water. Let the assembly dry thoroughly before installation.

 **NOTE:** In cases of heavy volatiles, steam cleaning or the use of solvents, such as acetone, may be necessary. Be sure to test a small area with the solvent you have selected to be sure there is no adverse reaction.

**5** Insert the demister carefully back into the demister carriage and then replace the entire assembly back into the demister housing.

**6** Inspect the condition of the gasket. If it is damaged, replace the gasket.

**7** Secure the cover in place using the original thumbscrews.





# **Addendum**

# **Communication Protocols for**

# **Common Controls**

**Modbus Communications, Ethernet Communications, DeviceNet Gateway  
Communications and SPI Communications**

**DISCLAIMER:** Conair shall not be liable for errors contained in this User Guide or for incidental, consequential damages in connection with the furnishing, performance or use of this information. Conair makes no warranty of any kind with regard to this information, including, but not limited to the implied warranties of merchantability and fitness for a particular purpose.

# Table of Contents

## A-1 Modbus Communications

Description of Modbus communications .....	A-2
Installing the Modbus communication hardware .....	A-2
Using the Modbus parameter list .....	A-2

## B-1 Ethernet Communications

Description of Ethernet communications .....	B-2
Installing the Ethernet communication hardware .....	B-2
Using the Ethernet parameter list .....	B-3

## C-1 DeviceNet Communications

Description of DeviceNet communications .....	C-2
Installing the DeviceNet communication hardware .....	C-2
Using the DeviceNet communication dip switch settings .....	C-2
Using the LED status indicators .....	C-5
Configuring the DeviceNet software	
Installing the EDS files .....	C-5
EDS file parameter list configuration options .....	C-6
Adding the gateway to the scan list .....	C-8
Explicitly writing to the gateway .....	C-11
Gateway parameter list .....	C-12

## **D-1** SPI Communications

Description of SPI communications . . . . .	D-2
Installing the SPI communication hardware . . . . .	D-2
Configuring the SPI communication software . . . . .	D-2
Supporting dryer SPI commands. . . . .	D-4

## **A** Appendix

Modbus RS-232/485 serial communications parameters . . . . .	A-1
DC-2 control parameters (used on dryers with DC-2 controls) . . . . .	A-1
DC plus control parameters (used on ResinWorks or Hopper Temperature Controllers (HTC)) . . . . .	A-2
Related drawings . . . . .	A-3
Modbus TCP/IP communications parameters . . . . .	A-4

# Modbus Communications

---

Description of Modbus Communications . . . . A-2

Installing the Modbus

    Communication Hardware . . . . . A-2

Using the Modbus Parameter List. . . . . A-2

# Description of Modbus Communications

The common controls series of products from Conair use standard Modbus communications protocol to allow the user to access the control boards for supervisory type functions. For example, you may want to display the drying temperature for all hoppers in a facility in one central location. By connecting all the dryers to a central computer, the temperatures and setpoints can be displayed in one location using a standard SCADA software program such as Wonderware or RSView.

Depending on the particular common controls board, the Modbus serial communication interface may be either RS-232 (DC-2 control board) or RS-485 (DC control board). Converters may be ordered with the product to convert from one to the other. The RS-485 standard allows multiple controllers to be daisy-chained together over longer distances while the RS-232 allows direct connection to most personal computers without an interface adapter.

## Installing the Modbus Communication Hardware

The hardware required for Modbus communications is included with the product when it is shipped. Connectors and cabling must be supplied by the user or ordered from Conair. A converter is available if your controls do not use the standard communications you desire. See Appendix A page A-3 for the proper cabling and connection information for both types of interface.

## Using the Modbus Parameter List

The Modbus interface uses standard Modbus protocol to communicate with a common controls system. The data that may be retrieved is arranged in a parameter list. By using the Modbus register read and write commands, the desired data may be read from or written to the controller. The list of data that may be set or retrieved with the common controls system is arranged in Modbus registers 500 to 539.

See Appendix A page A-1 for the data contained in this area for your particular type of equipment. DC-2 control parameters are used on a dryer with a DC-2 control panel and DC plus control parameters are used with Hopper Temperature Controllers (HTC) or ResinWorks.

# Using the Modbus Parameter List

**(continued)**



**CAUTION:** The list of data that may be read and written to by the user is arranged in a specific location (parameters 500 to 540). Writing to a location with improper data, or writing to an incorrect location outside of the specified range may cause your common controls system to become inoperative or to operate in a manner that may damage your process. Be certain that you understand each parameter and its effect before changing anything. Conair recommends that you initially attempt to read from the registers and do not attempt any writes. Once the information you are trying to read has been confirmed as accurate, you can program your new/additional data.



# **Ethernet Communications**

---

Description of Ethernet Communications . . . .	B-2
Installing the Ethernet	
Communication Hardware . . . . .	B-2
Using the Ethernet Parameter List . . . . .	B-3

# Description of Ethernet Communications

Modbus TCP/IP is a protocol that takes the basic Modbus command set that was originally developed for serial communications, and applies it to the Ethernet standard via TCP/IP protocol. Beginning in 2006 this protocol can be ordered as an option on the Common Control's dryers. When the option is ordered, an additional Ethernet module is soldered on to the main control board of the dryer. This Ethernet module can not be added to an existing dryer control board. Adding the option to an existing dryer will require replacing the main control board with a new board containing the Ethernet module. Depending on the revision level and display type, the display board may need to be replaced. For easier set-up, a short length of Ethernet cable is run from the connector on the control board to an Ethernet receptacle mounted on the control enclosure. This allows you to plug into the Ethernet port without having to open the control enclosure.

## Installing the Ethernet Communication Hardware

The control boards are shipped with a default Internet Protocol (IP) address of 010.001.010.254. In order for your dryer to communicate with your network, this default IP address should be changed to match the network structure used in your plant. Changing the IP address is accomplished through the DC-2 operator interface display board.

**To change the IP address:**

- 1 Enter the supervisory level password (0210).** See your dryer manual for directions if necessary.
- 2 Once the password has been entered, go to “Setup”>”Other”>Comm.**
- 3 When the “Comm” menu is displayed, scroll down through the list until “IP Addr Part 1” is displayed.** This is the first octet (first three numbers) of the IP address. For example if the IP address is 192.168.0.100, “192” would be shown as the value in this field. If desired, change the first octet at this location.

(continued)

## Installing the Ethernet Communication Hardware (continued)

- 4 Once you have entered the correct value, scroll down one more time until “IP Addr Part 2” is displayed. This is the second octet (first three numbers) of the IP address and may be changed if necessary.
- 5 Scrolling further down you will see additional fields for the remaining IP address octets, the subnet mask and the gateway. Once all fields have been changed, cycling the power to the dryer will complete the process and reinitialize the Ethernet interface.

## Using the Ethernet Parameter List

Please refer to page Appendix A page A-4 for a list of the parameters that are available with the Modbus TCP/IP interface.



**CAUTION:** Writing to a location with improper data, or writing to an incorrect location outside of the specified range may cause your common controls system to become inoperative or to operate in a manner that may damage your process. Be certain that you understand each parameter and its effect before changing anything. Conair recommends that you initially attempt to read from the registers and do not complete any writes. Once the information you are trying to read has been confirmed as accurate, you can now program in your new or additional data.



**NOTE:** The list of parameters that may be read and written to via Modbus TCP/IP is extensive. Some of these parameters are naturally a part of the operation of the machine and others may be obscure configuration settings. The parameter list in Appendix A page A-4 includes a column with a recommendation as to whether the parameter should be accessed by a user program. Addresses that are not consecutive indicate that there are other parameters present which are not recommended for usage by the user.



# DeviceNet Communications

---

Description of DeviceNet Communications . . .	C-2
Installing the DeviceNet	
Communication Hardware . . . . .	C-2
Using the DeviceNet Communication	
Dip switch Settings . . . . .	C-2
Using the LED Status Indicators. . . . .	C-5
Configuring the DeviceNet Software	
Installing the EDS Files . . . . .	C-5
EDS File Parameter List	
Configuration Options . . . . .	C-6
Adding the Gateway to the Scan List. . . .	C-8
Explicitly Writing to the Gateway . . . . .	C-11
Gateway Parameter List . . . . .	C-12



# Description of DeviceNet Communications

The Conair Common Control board set allows you to add DeviceNet communications for information interchange with PLC systems or higher level supervisory computer systems. The DeviceNet communication is accomplished with a gateway device that converts the Modbus communications already existing on the DC-2 display board or the DC control cabinet , but may also be purchased with a DIN rail mounted enclosure. It is available with RS-232 (for the DC-2 control) or RS-485 (DC control) communications capability. These instructions assume the user is familiar with basic DeviceNet configuration and use. If not, please refer to manuals from your DeviceNet provider before attempting to use this function.

## Installing the DeviceNet Communication Hardware

The DeviceNet Gateway is designed to mount to three standoffs which are attached to the door of the control cabinet below the main control board. Note that the gateway circuit board has two holes to mount the gateway and the board just rests on the third standoff to help stabilize the board. Cable 188629-04 connects between the gateway's three pin connector and the control board, connector J4. The DeviceNet drop cable is then ran to the five pin connector on the gateway.

## Using the DeviceNet Communication Dip Switch Settings

The gateway has two groups of DIP switches for setup. The first set of switches (labeled S1 on the circuit board or next to the "address" label on the enclosure) is used to configure the address of the gateway on the DeviceNet network and the baud rate used by the gateway for DeviceNet communications. The second set of switches (labeled S2 on the circuit board or next the "number of controllers label) is used to set the number of controllers attached to the gateway (only for RS-485 communications), to set the baud rate used to communicate between the gateway and the dryer, and to set the number of words of data transferred from the gateway to the DeviceNet scanner (10 or 20 words of data). See next page for dip switch configuration.

# Using the DeviceNet Communication Dip Switch Settings

(continued)

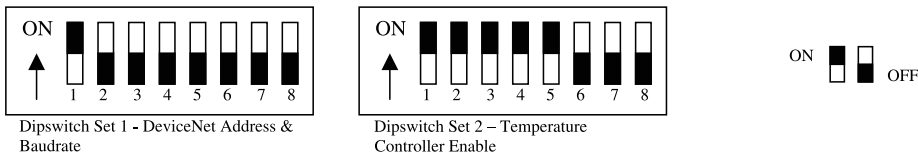

Figure I – Dipswitch Layout

Address (Decimal)	SW1 2 <sup>0</sup>	SW2 2 <sup>1</sup>	SW3 2 <sup>2</sup>	SW4 2 <sup>3</sup>	SW5 2 <sup>4</sup>	SW6 2 <sup>5</sup>
Default						
01	ON	OFF	OFF	OFF	OFF	OFF
15	ON	ON	ON	ON	OFF	OFF
40	OFF	OFF	OFF	ON	OFF	ON

Table 1 - Dipswitch Set 1 - DeviceNet Address

Baud Rate / Mode	SW7 2 <sup>6</sup>	SW8 2 <sup>7</sup>
125K	OFF	OFF
250K	ON	OFF
500K	OFF	ON
Software	ON	ON

Table 2 - Dipswitch Set 1 - DeviceNet Baud Rate

Dip switch 1 provides the DeviceNet MacId address and baud rate using the standard switch configurations found in most DeviceNet products. Switches 7 and 8 of switch set 1 allow the user to use DeviceNet software configuration tools to set the MacId address and baud rate. Factory default switch settings are 125k , Address 63.

(continued)

# Using the DeviceNet Communication Dip Switch Settings (continued)

Number Controllers	SW5	SW6	SW7	SW8
1	ON	OFF	OFF	OFF
2	OFF	ON	OFF	OFF
3	ON	ON	OFF	OFF
4	OFF	OFF	ON	OFF
5	ON	OFF	ON	OFF
6	OFF	ON	ON	OFF
7	ON	ON	ON	OFF
8	OFF	OFF	OFF	ON

Table 3 - Dipswitch Set 2 - Enable Athena Controllers

Dip switch set 2 identifies the Modbus addresses of controllers connected to the DeviceNet interface. From one to eight controllers can be enable for communication through a single Athena DeviceNet interface module.

ModBus Baud Rate	SW4
19200	ON
9600	OFF

Table 4 – Dipswitch Set 2 - Modbus Baud Rate

Dip switch set 2 position 4 identifies the baud rate used to read parameters on Modbus.

Modbus Parameters	SW1	SW2
User Configurable	OFF	OFF
Parameters 500 – 519	OFF	ON
Parameters 500 - 509	ON	OFF
User Configurable	ON	ON

Table 5 – Dipswitch Set 2 - Modbus Parameter List

Dip switch set 2 positions 1-2 identify the parameter list for the Conair controllers.

# Using the LED Status Indicators

There are two LEDs on the gateway which display the status of the communications. The first LED, which is located between the dip switches (labeled “Controllers” on the gateways with the enclosure), display the status of the Modbus communications between the gateway and the control circuit board. The second LED (labeled “DeviceNet” on the gateways with the enclosure) display the status of the DeviceNet communications.

## 1. Controller Status LED (between dip switches)

Color	State	Indication
None	Off	No power
Red	Solid	No controllers online
Red	Flashing	“Illegal Date” error
Green	Solid	Normal operation - All controllers online
Green	Flashing	One or more controllers offline or not present

## 2. DeviceNet Status LED

Color	State	Indication
None	Off	No power
Red	Solid	Unrecoverable DeviceNet fault
Red	Flashing	Output error or configuration error
Green	Solid	Normal operation
Green	Flashing	Device is in idle mode or not allocated to a master

# Configuring the DeviceNet Software

## Installing the EDS Files

There are multiple EDS (electronic data sheet) files associated with the gateway depending on how many controllers are attached to a gateway. The files are named based on the number of controllers (i.e. an EDS file for a gateway with three controllers attached is named 3Conair.EDS). Choose the appropriate file for your application and install it using your DeviceNet network’s EDS installer options. Once the EDS files are installed they will be shown under the “Conair Common Control” heading in the EDS file manager. If you install more than one of the EDS files the files will all be named “Conair Common Control” with the hexadecimal designator to differentiate the different files. By opening the devices parameter list you can tell how many controllers are associated with the EDS file.

(continued)

## Configuring the DeviceNet Software Installing the EDS Files (continued)

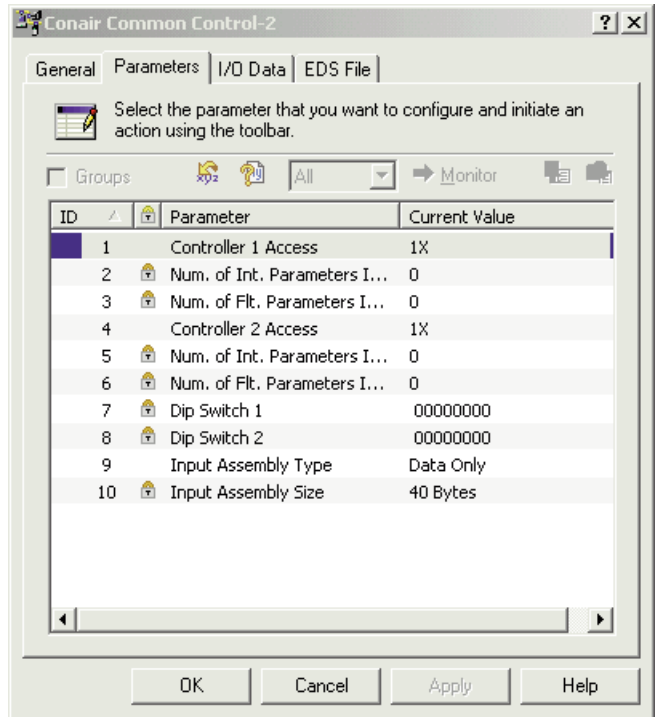

## Configuring the DeviceNet Software EDS File Parameter List Configuration Options

Once the EDS file has been installed the gateway may be added to a network configuration. There are a number of parameters that may be configured for each gateway to optimize it for your application. The number of parameters will vary depending on how many controllers are attached to a gateway.

# Configuring the DeviceNet Software

## EDS File Parameter List Configuration

### Options (continued)

There are seven types of parameters:

#### **Parameter 1    Controller Access    1X, 10X, 100X**

This parameter controls, the format of the data that is retrieved from the controller. If 1X is chosen the data will be retrieved as a whole number with no implied decimal place. For example, if a process temperature was retrieved and the real value of the temperature was 225.3927, the temperature would be read as 225 using the 1X register format. If 10X was chosen the raw data would be retrieved as 2253, requiring the user to add the implied decimal point to show the temperature as 225.3. Similarly, if the data was retrieved in the 100X format the raw data would be 22539 requiring the user to add the decimal place to display it as 225.39.

#### **Parameter 2    Number of Int. Parameters    0 to 40**

This field will display how many integer parameters are retrieved from the controller. This will be either 10 or 20 depending on the position of dip switch 2, switches 1 and 2.

#### **Parameter 3    Number of Flt Parameters    0 to 10**

This field will display how many floating point parameters are retrieved from the controller. The default is zero and is not normally changed by the user. If your application requires the use of floating point numbers, please consult with a Conair representative.

#### **Parameter 4    Dip switch 1    Combination of 1's and 0's**

This field shows the actual positions of dip switch 1 on the gateway.

#### **Parameter 5    Dip switch 2    Combination of 1's and 0's**

This field shows the actual positions of dip switch 2 on the gateway.

# Configuring the DeviceNet Software

## EDS File Parameter List Configuration

### Options (continued)

#### Parameter 6 Input Assembly Type    Status only, Status w/data, Data only

This field will choose whether the data retrieved consists of only the process data from the controller (data only), the status bytes from the gateway (status only), or the data and the status bytes (status w/data).



**NOTE:** When this field is modified the change must be applied. The size of the data block being retrieved (see parameter 7) will change based on the configuration of this parameter.

#### Parameter 7 Input Assembly Size    0 to 160

This field will display the actual size of the input data that is being retrieved from the gateway to the master on the DeviceNet network. See the section on adding the gateway to the scan list for further information on the parameter.

# Configuring the DeviceNet Software

## Adding the Gateway to the Scan List

Adding the gateway to a scan list requires that the data area is sized correctly and mapped to the correct locations.

**To add the gateway to the scan list:**

- 1** Set all dip switches as described in the *“DeviceNet communications section, entitled Using the DeviceNet communication dip switch settings”*.
- 2** Go online with the device on the network and set the parameters described in the *“DeviceNet communications section, entitled Configuring the DeviceNet software, EDS File Parameter List Configuration Options”*.
- 3** Once the parameters are set, download the parameters to the gateway using the *“Apply”* button.

# Configuring the DeviceNet Software

## Adding the Gateway to the Scan List

(continued)

- 4 Close the parameter list and reopen**, once you have applied your parameters. Check Parameter 7 to see how many bytes of data are in the input assembly size.
- 5 Go online with the scanner and move the gateway from the “Available Devices” area to the “Scanlist” area** using the arrow key. After the gateway has been moved, the “Edit I/O Parameters” button should be accessible.

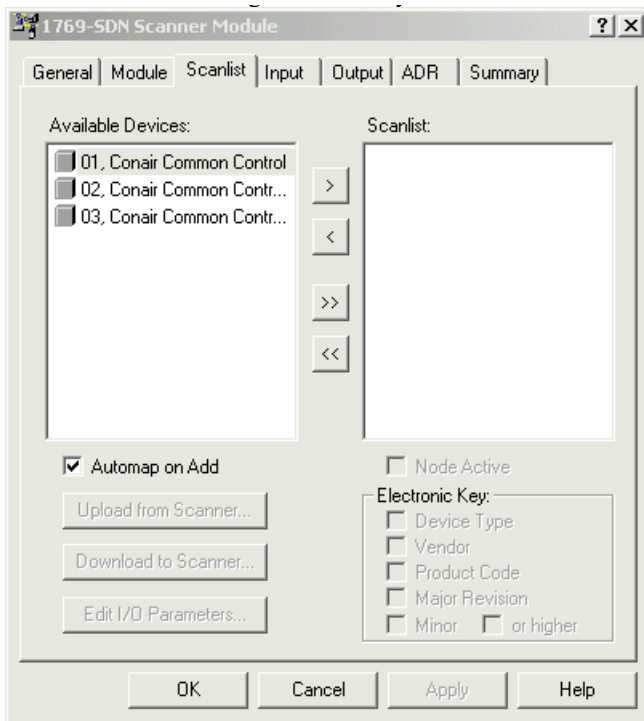

# Configuring the DeviceNet Software

## Adding the Gateway to the Scan List

(continued)

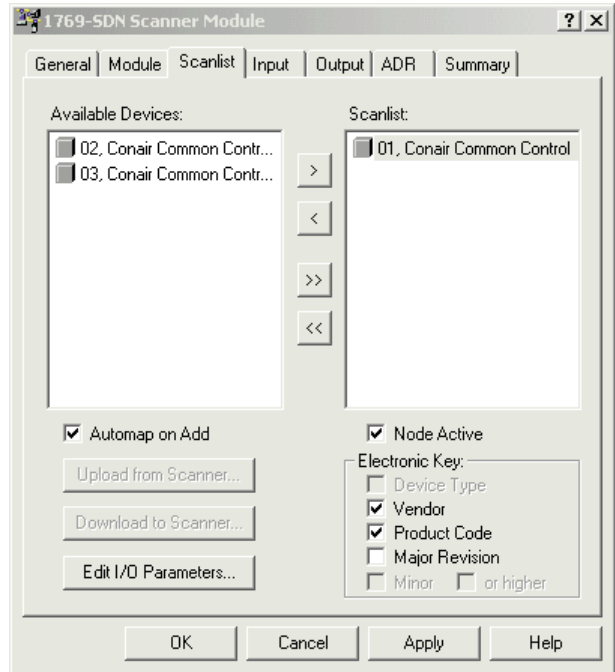

Press the “Edit I/O Parameter” button to to the configure the I/O parameters.

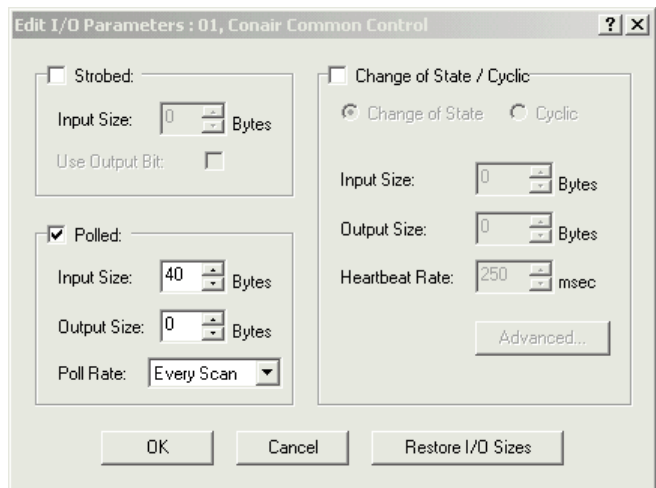

## Configuring the DeviceNet Software

### Adding the Gateway to the Scan List (continued)

- 6** Select the “OK” button once you have modified your input field size to match the number of bytes shown in Parameter 7. Since the actual data size being used differs from the maximum possible data size, you will get an error message noting this. Click the “OK” button to keep the data size you have entered.
- 7** Once the I/O parameters have been modified, the gateway may be mapped to your desired I/O area using the Input tab. Depending on whether your controller is 16 bit (Allen Bradley Micrologix) or 32 bit (Allen Bradley Controllogix) the data may transfer either as individual words (16 bit) or two parameter words may be combined into a DINT (32 bit). All parameters should now be accessible from the programmable logic controller. (PLC)

## Configuring the DeviceNet Software

### Explicitly Writing to the Gateway

As discussed above, the information from the Common Controls Systems can be set up to be read directly as inputs in a PLC system. In order to write data to the gateway it must be written in a DeviceNet Explicit message. The method was chosen to ensure that data is written once, only when the PLC decides it should be written. This reduces bandwidth on the network and ensures that the data is sent only when it is required. Note that parameters 530 to 539 are set up as the registers to write to the common controls devices. Please see your DeviceNet system provider’s information on using explicit messaging for more details.

## Configuring the DeviceNet Software Gateway Parameter List

Similarly to the Modbus communications, the Common Controls parameters that are available are stored in registers 500 to 539. The dip switches determine how much of the list is transferred to the PLC. If the dip switch is set for ten words, Modbus parameters 500 to 509 will be transferred to the input image of the scanner. If the dip switches are set for twenty words, Modbus parameters 500 to 519 will be transferred to the scanner. See Appendix A page A-1 for the actual parameters that are available from the type of common control device that your system is using.

# SPI Communications

---

Description of SPI Communications . . . . . D-2

Installing the SPI

    Communication Hardware . . . . . D-2

Configuring the SPI

    Communication Software . . . . . D-2

Supported Dryer SPI Commands . . . . . D-4



# Description of SPI Communications

The Society of Plastics Industry (SPI) has defined a standard protocol to be used for interconnecting plastics equipment. This protocol uses the RS-485 standard as the physical connection and defines stand addresses and commands to communicate with the various kinds of equipment in common use at a typical plastics facility. For example, a dryer is specified as Device ID 22 hex, a chiller is Device ID 21 hex. The data retrieved for each type of equipment is defined in the standard. For a dryer or other piece of equipment to be in compliance with the SPI standard you must be able to retrieve certain parameters such as the setpoint process temperature, high and low temperature deviation alarms, temperature to the process, temperature to the process, etc. Some parameters are also designated as optional parameters that may or may not be available depending on the equipment provider's discretion.

## Installing the SPI Communication Hardware

The SPI option is available with the DC-2 display boards. The display boards have a RS-232 port built into the board. The RS-232 to RS-485 converters are provided and mount on the inside of the door of the electrical cabinet. The RS-485 SPI signal is then brought to the outside of the cabinet by a 9 pin D-sub connector. Refer to Conair drawing 130024 and 188629 in Appendix A page A-3 for details of the installation. The RS-485 SPI signal is available on pins 4 and 5 of the DB-9 connector. Pins 8 and 9 also have the RS-485 connection (parallel with pins 4 and 5) to assist in daisy-chaining equipment together.

## Configuring the SPI Communication Software

The SPI protocol option must be turned on and configured in the operator display before it may be used.

### To setup the SPI communications:

- 1 Enter the supervisory level password (0210).** See your dryer manual for directions if necessary.

# Configuring the SPI Communication Software (continued)

- 2** Once the password has been entered, go to “Setup”>”Other”>Comm.
- 3** When the “Comm” menu is displayed, scroll down through the menu and set the “Protocol” to”SPI”. Set the slave ID to a unique address on the RS-485 network master. Once you have completed entering in your information, return to the opening menu and cycle the power on your equipment to establish the new settings.

In order to connect Conair equipment to a host computer system, Conair can provide an SPI-DDE server which will allow DDE compliant software packages such as Wonderware or Excel to connect to the SPI network with minimal programming required.

For more information on the SPI protocol, you can obtain the SPI Communication protocol manual by contacting:

The Society of Plastics Industry, Inc.  
1801 K Street, NW, Suite 600K  
Washington, D.C. 20006  
(202) 974-5200 Fax (202) 296-7005  
[www.plasticsindustry.com](http://www.plasticsindustry.com)



# Supported Dryer SPI Commands

SPI protocol defines two different modes, “Select” and “Poll”. “Select” commands are used to set or change the information in the dryer. For example, to change a temperature setpoint from 200°F to 250°F {93°C to 121°C} a “Select” command is used. “Poll” commands are used to read the information without changing or modifying it. For example, when you simply want to display the actual process temperature. In either case two hex command bytes are sent to the equipment to specify what communication action to take.

The following list shows the “Select” and “Poll” bytes along with a description of the information that may be retrieved from Conair dryers.

1. **Echo** - Allows the master to test a piece of equipment by writing 4 bytes of information to the equipment and then reading it back.

Select: 20h, 21h      Poll: 20h, 20h

2. **Version** - Read the SPI version from the equipment.

Select: NA      Poll: 20h, 22h

3. **Setpoint Process Temperature** - Sets and retrieves the process temperature setpoint.

Select: 20h, 31h      Poll: 20h, 30h

4. **Alarm, High Temperature Deviation** - Sets and retrieves the high temperature deviation alarm setpoint. Not that in Conair dryers there is actually only deviation setpoint that is used for both high and low temperature deviation. The last value written to either the high or the low will be the value that is used.

Select: 20h, 33h      Poll: 20h, 34h

5. **Alarm, Low Temperature Deviation** - Sets and retrieves the low temperature deviation alarm setpoint. Not that in Conair dryers there is actually only deviation setpoint that is used for both high and low temperature deviation. The last value written to either the high or the low will be the value that is used.

Select: 20h, 35h      Poll: 20h, 34h      (continued)

# Supported Dryer SPI Commands

**(continued)**

6. **Status, Process** - Indicates that the status of the process with each “bit” showing a particular condition.

The “bits” are defined as follows:

**Bit 0** - Processing (dryer running)

**Bit1** - Alarm, System (any alarm that indicates a problem that may affect the drying operation)

**Bit3** - Alarm, Machine (any alarm that indicates a problem with the dryer itself)

**Bit4** - Alarm, High Temperature Deviation

**Bit5** - Alarm, Low Temperature Deviation

**Bit6** - Reserved

**Bit7** - Reserved

**Bit8** - Alarm, Filter clogged

**Bit9** - Alarm, Low flow

**Bit10** - Alarm, High Dewpoint

**Bit11** - Reserved

**Bit12** - Reserved

**Bit13** - Reserved

**Bit14** - Temperature out of band deviation

**Bit15** - Not used

Select: NA

Poll: 20h, 40h

(continued)



# Supported Dryer SPI Commands

**(continued)**

7. **Status, Machine 1** - Indicates that the status of the dryer itself with each “bit” showing a particular condition.

**The “bits” are defined as follows:**

**Bit0** - Processing (dryer running)

**Bit1** - Alarm, System (any alarm that indicates a problem that may affect the drying operation)

**Bit2** - Alarm, Process (any alarm that indicates a problem with the process itself)

**Bit3** - Alarm, Machine (any alarm that indicates a problem with the dryer itself)

**Bit4** - Alarm, High Temperature (any temperature input)

**Bit5** - Alarm, Low Temperature (any temperature input)

**Bit6** - Reserved

**Bit7** - Reserved

**Bit8** - Reserved

**Bit9** - Alarm, Low flow

**Bit10** - Alarm, High voltage (not supported)

**Bit11** - Alarm, Low voltage (not supported)

**Bit12** - Alarm, High current (not supported)

**Bit13** - Alarm, Low current (not supported)

**Bit14** - Alarm, Phase

**Bit15**- Not used

Select: NA

Poll: 20h, 42h

(continued)

# Supported Dryer SPI Commands

**(continued)**

8. **Status, Machine 2** - This word shows the status of the Dryer itself with each bit showing a particular condition.

**The “bits” are defined as follows:**

**Bit0** - Processing (dryer running)

**Bit1** - Alarm, System (any alarm that indicates a problem that may affect the drying operation)

**Bit2** - Alarm, Process (any alarm that indicates a problem with the process itself)

**Bit3** - Alarm, Machine (any alarm that indicates a problem with the dryer itself)

**Bit4** - Fault Sensor

**Bit5** - Fault, Calibration

**Bit6** - Reserved

**Bit7** - Reserved

**Bit8** - Reserved

**Bit9** - Reserved

**Bit10** - Reserved

**Bit11** - Reserved

**Bit12** - Reserved

**Bit13** - Reserved

**Bit14** - Reserved

**Bit15**- Reserved

Select: NA

Poll: 20h, 44h

(continued)



# Supported Dryer SPI Commands

(continued)

9. **Mode, Machine** - This is used to start/stop the dryer, acknowledge alarms and observe the run status.

**Bit0** -Start/Stop (1 = running or start, 0 = stop or stopped)

**Bit1** - Acknowledge Alarms

Select: 20h, 49h

Poll: 20h, 48h

10. **Temperature, To Process** - This is the actual the actual process (drying) temperature controlled by the dryer.

Select: NA

Poll: 20h, 70h

11. **Temperature, From Process** - This is the actual temperature as read by the RTD at the exit of the drying hopper. This is the temperature that is used for setback control in the dryer. Note that this is an optional feature and the value may be invalid if the feature is not installed on the dryer.

Select: NA

Poll: 20h, 72h

12. **Flow, To Process** - This is the flow of dry air to the process. Note that this is an optional feature and the value may be invalid if the feature is not installed on the dryer.

Select: NA

Poll: 20h, 78h

13. **Dewpoint** - This is the actual dewpoint of the process air. Note that this is an optional feature and the value may be invalid if the feature is not installed on the dryer.

Select: NA

Poll: 20h, 7Ch

14. **Setpoint, High Dewpoint Alarm** - This is the setpoint for the dewpoint alarm triggered by 13.

Select: 20h, 81h

Poll: 20h, 80h

# Modbus RS-232/485 Serial Communication Parameters

## DC-2 Control Parameters - Used on dryers with DC-2 Controls

### Read Area

Modbus Register Number	Description	Comments
500	Product Type	
501	Process Temperature Setpoint	
502	Process Actual Temperature	
503	Process Temperature Setpoint (Setback)	
504	Return Air Temperature Out of Hopper	
505	Return Air Setpoint (Setback)	
506	Regeneration Actual Temperature	
507	Dewpoint Actual	
508	Operational Mode	
509	Running Status	
510	Return Air Actual	
511	Shutdown Alarms	
512	Passive Alarms	
513	Load Rate Setpoint (Setback)	
514	Average Load Rate Actual (Setback)	
515	Process Heater Output Actual %	
516	Regeneration Heater Output Actual %	
517	Process Protect Actual Temperature	
518	Product Type	
519	Product Type	

### Write Area

Modbus Register Number	Description	Comments
530	Process Temperature Setpoint	
531	Process Temperature Setpoint (Setback)	
532	Return Air Setpoint (Setback)	
533	Load Rate Setpoint (Setback)	
534	PM 1 Dewpoint Setpoint	(continued)

## **Modbus RS-232/485 Serial Communication Parameters (continued)**

Modbus Register Number	Description	Comments
535	Start Command	1 = start
536	Stop Command	1 = stop
537	Alarm Acknowledge	
538	Process Temperature Setpoint	
539	Process Temperature Setpoint	

### **DC Plus Control Parameters - Used on ResinWorks and Hopper Temperature Controllers (HTC)**

Modbus Register Number	Description	Comments
500	Product Type	
501	Process Temperature Setpoint	
502	Process Actual Temperature	
503	Process Temperature Setpoint (Setback)	
504	Return Air Temperature Out of Hopper	
505	Return Air Setpoint (Setback)	
506	Load Rate Setpoint (Setback)	
507	Average Load Rate Actual (Setback)	
508	Operational Mode	
509	Running Status	
510	Process Heater Output Actual %	
511	Alarms	
512	RTD Integrity Alarms	
513	Regeneration Actual Temperature	
514	Regeneration Heater Output Actual %	
515	Process Protect Actual Temperature	
516	Product Type	
517	Product Type	
518	Product Type	
519	Product Type	

# Modbus RS-232/485 Serial Communication Parameters (continued)

## DC Plus Control Parameters - Used on ResinWorks and Hopper Temperature Controllers (HTC)

Modbus Register Number	Description	Comments
530	Process Temperature Setpoint	
531	Process Temperature Setpoint (Setback)	
532	Return Air Setpoint (Setback)	
533	Load Rate Setpoint (Setback)	
534	PM 1 Dewpoint Setpoint	
535	Start Command	1 = start
536	Stop Command	1 = stop
537	Alarm Acknowledge	
538	Process Temperature Setpoint	
539	Process Temperature Setpoint	

## Related Drawings

130023 - Common Controls DeviceNet Gateway Assemblies, D dryers  
130023-02 - CDDS DeviceNet Gateway Assembly  
130023-03 - Common Controls DeviceNet Gateway Assemblies, W dryers  
13024 - Common Controls SPI Communications Assembly  
188629 - Common Controls 24 VAC Power and Comms Cables  
18865201 - W15-100 Dryer SPI Control Communications Assembly  
18865202 - WMDC15-100 Dryer SPI Control Communications Assembly  
18865203 - W150-5000 Dryer SPI Control Communications Assembly  
18865204 - W15-100 Dryer Modbus Control Communications Assembly  
18865205 - WMDC15-100 Dryer Modbus Control Communications Assembly  
18865206 - W150-500 Dryer Modbus Control Communications Assembly  
18865207 - W15-100 Dryer DeviceNet Control Communications Assembly  
18865208 - WMDC15-100 Dryer DeviceNet Control Communications Assembly  
18865209 - W150-5000 Dryer DeviceNet Control Communications Assembly  
18865210 - W Dryer Ethernet Control Communications Assembly

# Modbus TCP/IP Communications Parameters

**Legends:**  
 F Floating Point Parameter  
 I Integer Parameter  
 RO Read Only  
 WO Write Only

Rev.01

## Conair Dryer Enhanced Main Control Board

Modbus Address	Type	Description	Default	Range	Recommended for Customer Reads	Recommended for Customer Writes	Comments
40001	I	Dryer Type	1	0 Central Dryer (No process heater) 1 Standard Dryer 2 Unused 3 1-Hopper MDC 4 2-Hopper MDC	Y	N	
40002	I, RO	Control Board Software Version		xxxx base 5 digits x = 1, Small Electric Dryer = 2, Small Electric Dryer = 3, Small Electric Dryer yy Major release zz Minor release	Y	N	
40016	I	Drying Monitor High Alarm Delay	1	0-30 Min.	Y	Y	
40017	I	Stop Conveying if Shutdown Alarm Active	1	0- No 1- Yes	Y	Y	
40018	I	Delay Time for Stopping Conveying	60	0- 240 Min.	Y	Y	
40020	I	Self Loading Option (Wheel)	0	0- Machine Loader Only	Y	Y	
40021	I	Hopper Loader Virgin Load Time (Wheel)	5	2- Ratio Valve + Option1	Y	N	
40022	I	Hopper Loader Reprim Load Time (Wheel)	5	1- 60 Sec.	Y	Y	
40023	I	Hopper Loader Load Time (Wheel)	5	1- 60 Sec.	Y	Y	
40024	I	Layering On/Off (Wheel)	0	0- Off 1- On	Y	Y	
40041	I, RO	Operating Mode	1	0 Power Up 1 Standby 2 Starting 3 Stopping 4 Autotuning 5 Calibrating 6 Running 7 Indexing 8 Index End 9 Index Reset 10 Test Mode	Y	N	
40042	I, RO	Running Status	0	Bit values. MSB=7. LSB=0. This returns the actual running status. Bit value No = 0 Yes = 1 =====	Y	N	

0 Ready To Run  
 1 Hop1 Setback Active  
 2 60 Sec. Prior to Index  
 3 PMI Active  
 4 Alarm Silenced  
 5 Shutdown Alarm Active  
 6 Passive Alarm Active  
 7 Hop2 Setback Active  
 8 Booster2 is Ramping  
 9 Access is Ramping  
 10 Backs Ramp  
 11 DeepPoint Control Active  
 12 Pre-Cooler Active

40043	I, RO	Shutdown Alarm Status	0	<p>Bit values, MSB=15, LSB=0. This returns the actual shutdown alarm status. Bit value: Inactive = 0 Active = 1</p> <pre> ===== 0 Process High Temperature 1 Process Temperature Loop Break 2 Process Heater Box High Temperature 3 Process Protection High Alarm 4 Regen Heater Box High Temperature 5 Regen Heater Box High Temperature 6 Carousel Index Too Long 7 Carousel Index Failure 8 Return Air High Temperature 9 Unused 10 Unused 11 Matchdog Timeout 12 Booster2 Heater Box High Temperature 13 Phase Error 14 Epsilon Weirce Error 15 Process Blower Overload </pre>	Y	N	
40044	I, RO	Passive Alarm Status	0	<p>Bit values, MSB=15, LSB=0. This returns the actual passive alarm status. Bit value: Inactive = 0 Active = 1</p> <pre> ===== 0 Process Temperature Deviation 1 Process Low Temperature 2 Regen Temperature Deviation 3 Regen Low Temperature 4 Regen High Temperature 5 Regen Temperature Loop Break 6 Return Air Mid-High Temperature 7 After-Cooler Loop Break 8 Process Dewpoint (PM1) 9 Process Filter Clogged 10 CFM low 11 CFM high 12 Drying Monitor Low Temperature 13 Drying Monitor Temperature not Met 14 After-Cooler Loop Break 15 MFC Conveying Blower Overload </pre>	Y	N	
40045	I, RO	Temp Input Integrity Status	0	<p>Bit values, MSB=7, LSB=0. This returns the actual RTD integrity status. Bit value: Good = 0 Bad = 1</p> <pre> ===== 0 Booster2 Probe 1 Regen Probe 2 Regen Temperature Probe 3 Out of Hopper2 Probe 4 Return Air Temperature Probe 5 Process Protection Probe 6 Out of Hopper Probe 7 Regen Out of Wheel Probe 0 0 to 100% 1 0 to 100% 2 0 to 100% 3 0 to 100% 4 0 to 100% 5 0 to 100% 6 0 - 1000 min. 7 0 - 1000 min. 8 0 - 1000 sec. 9 0 - OFF 10 1- T3 11 2- T4 12 3- T5 13 4- T6 14 0 - 30 minutes 15 1 - 24 Hours </pre>	Y	N	
40189	I	DM2 Alarm Selection	0		Y	Y	One probe must be selected for Drying Monitor operation.
40193	I	DM2 Alarm Delay	5		Y	Y	
40194	I	DM2 Temperature not Met Time	4		Y	Y	





# What is the Conair Hard Piping Kit?

Conair's Hard Piping Kit is for use with your drying system. Conair recommends the hard pipe kit for line sizes of eight inches and larger. This kit is an upgrade over the standard flex hose.

Hard pipe kits are recommended because they:

- eliminate the possibility of sag or collapse, especially around corners where those are common issues with flex hose.
- eliminate the possibility of restricted air flow due to hose damage (collapse, puncture, leaking, moisture infiltration).
- minimize maintenance needs.
- create a more permanent finished appearance.
- reduce air flow drag due to the smooth interior surface.

For more information about adding a Conair Hard Pipe Kit to your drying system, contact Conair.

Conair's sales number is 724-584-5500.

Conair's Instant Access  
24/7 Parts and Service number is 800-458-1960.  
Outside the U.S., dial 814-437-6861.



# How Does it Work?

Conair's Hard Piping Kit is a complete modular system. Each component utilizes a flanged end that is precision engineered to a perfect 90° angle to produce an accurate seal every time. The system utilizes simple to use clamp rings to quickly connect the components. This extremely strong and reliable connection system has been tested and approved for up to three bar shock explosion resistance.

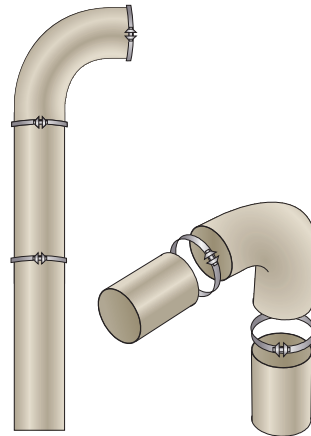

## Unpacking the boxes

Your hard piping kit components will vary depending on which kit you ordered. Kits are often customized for each customer.

If your hard pipe kit was ordered as one of the standard kits, below is what you should expect to find when you unpack the boxes.

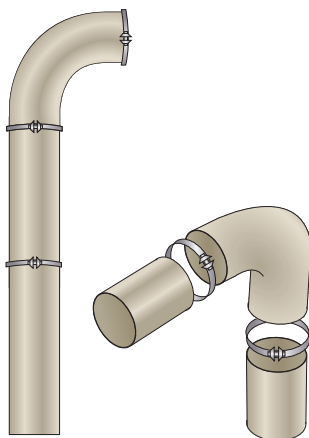

### Conair Part #18090001: 8 inch Hard Pipe Basic Kit

- Seven (7) 8 inch 1D 90, 16 GA, coated CS (PN 2671310201)
- Two (2) welded tube, 8 inch x 78 inch, coated CS, 19 GA (PN 2671291001)
- Five (5) welded tube, 8 inch x 39 inch, coated CS, 19 GA (PN 2671290901)
- Five (5) welded tube, 8 inch x 20 inch, coated CS, 19 GA (PN 2671290801)
- Four (4) welded slip tube, 8 inch x 20 inch, coated CS, 19 GA (PN 2671330501)
- Two (2) welded slip tube, 8 inch x 8 inch, coated CS, 19 GA (PN 2671330401)
- Six (6) 8 inch slip tube ring seal (PN 26713202)
- Six (6) Conair flange adaptors (PN 18477901)
- Twenty-six (26) 8 inch bolted pull ring, galvanized (PN 2671350201)
- Twenty (20) 8 inch U-shaped gasket, 19 GA (PN 2671360201)
- Six (6) 8 inch Conair hard pipe gasket (PN 185107930)
- Six (6) 8 inch ceiling mount clamp, Galvanized, high-temp. (PN 2671390201)
- Forty-eight (48) 5/16-18NC x 1 inch hex head wiz lock cap screw (PN 21202504)
- Forty-eight (48) 516-18 hex head wiz lock nut (PN 22300804)
- Six (6) threaded rod, 3/8-16 x 10 feet long (60 feet total length) (PN 2190091004)
- Six (6) threaded rod adapter (PN 18598074)
- Six (6) hex head bolt, M10 x 1.5 x 15MM, plated (PN 21247302)
- Eighteen (18) washer, flat, 3/8 inch, plated (PN 22500302)

### Conair Part #18090002: 12 inch Hard Pipe Basic Kit

- Two (2) 8 inch Conair hard pipe gasket (PN 185107930)
- Two (2) 8 inch hard pipe flange x 12 inch tubing adaptor (PN 18477910)
- Seven (7) 12 inch 1D 90, 16 GA, coated CS
- Three (3) welded tube, 12 inch x 78 inch, coated CS, 19 GA (PN 2671291501)
- Six (6) welded tube, 12 inch x 39 inch, coated CS, 19 GA (PN 2671291401)
- Six (6) welded tube, 12 inch x 20 inch, coated CS, 19 GA (PN 2671291301)
- Four (4) welded slip tube, 12 inch x 20 inch, coated CS, 19 GA (PN 2671330901)
- Two (2) welded slip tube, 12 inch x 8 inch, coated CS, 19 GA (PN 2561330701)
- Six (6) 12 inch slip tube ring seal (PN 26713203)
- Six (6) 12 inch Conair flange to 12 inch adapter (PN 18477902)
- Twenty-nine (29) 12 inch bolted pull ring, galvanized (PN 2671350301)
- Twenty-three (23) 12 inch U-shaped gasket, 19 GA (PN 2671360301)
- Six (6) 12 inch Conair hard pipe gasket (PN 185107916)
- Six (6) 12 inch ceiling mount clamp, galvanized, high-temp (PN 2671390301)
- Sixty-four (64) 5/16-18NC x 1 inch hex head wiz lock cap screw (PN 21202504)
- Sixty-four (64) 516-18 hex head wiz lock nut (PN 22300804)
- Six (6) threaded rod, 3/8-16 x 10 feet long (60 feet total length) (PN 2190091004)
- Six (6) threaded rod adapter (PN 18598074)
- Six (6) hex head bolt, M10 x 1.5 x 15MM, plated (PN 21247302)
- Eighteen (18) washer, flat, 3/8 inch, plated (PN 22500302)

## Unpacking the boxes (continued)

### Conair Part #18090003: 8 inch Hard Pipe GT Kit

- Two (2) 8 inch 1D 90, 16 GA, coated CS (PN 2671310201)
- One (1) welded tube, 8 inch x 78 inch, coated CS, 19 GA (PN 2671291001)
- One (1) welded tube, 8 inch x 39 inch, coated CS, 19 GA (PN 2671290901)
- One (1) welded tube, 8 inch x 20 inch, coated CS, 19 GA (PN 2671290801)
- One (1) welded slip tube, 8 inch x 39 inch, coated CS, 19 GA (PN 2671330601)
- One (1) welded slip tube, 8 inch x 20 inch, coated CS, 19 GA (PN 2671330501)
- One (1) welded slip tube, 8 inch x 8 inch, coated CS, 19 GA (PN 2671330401)
- Three (3) 8 inch slip tube ring seal (PN 26713202)
- One (1) Conair flange adaptors (PN 18477901)
- Nine (9) 8 inch bolted pull ring, galvanized (PN 2671350201)
- Six (6) 8 inch U-shaped gasket, 19 GA (PN 2671360201)
- Two (2) 8 inch hose, high temp (PN 2400071002)
- One (1) 8 inch Conair hard pipe gasket (PN 185107930)
- Four (4) 8 inch hose clamps (PN 24900124)
- Six (6) 8 inch insulation (PN 25902417)
- One (1) 8 inch 90° insulation (PN 18195701)
- Eight (8) 5/16-18NC x 1 inch hex head wiz lock cap screw (PN 21202504)
- Eight (8) 516-18 hex head wiz lock nut (PN 22300804)
- Twenty-five (25) feet of 3 inch ASJ SSL insulation tape (PN 25910404) (insulation)

For more information about adding a Conair Hard Pipe Kit to your drying system, contact Conair.

Conair's sales number is 724-584-5500.

Conair's Instant Access 24/7 Parts and Service number is 800-458-1960. Outside the U.S., dial 814-437-6861.

### Conair Part #18090004: 12 inch Hard Pipe GT Kit

- Two (2) 8 inch hose connection, coated CS, 19 GA (PN 2671400201)
- Two (2) 8 inch hose, high temp (PN 2400071002)
- Two (2) 8 inch Conair hard pipe gasket (PN 185107930)
- Two (2) 8 inch hard pipe flange x 12 inch tubing adaptor (PN 18477910)
- Four (4) 8 inch hose clamps (PN 24900124)
- Two (2) 12 inch 1D 90, 16 GA, coated CS
- One (1) welded tube, 12 inch x 78 inch, coated CS, 19 GA (PN 2671291501)
- One (1) welded tube, 12 inch x 39 inch, coated CS, 19 GA (PN 2671291401)
- One (1) welded tube, 12 inch x 20 inch, coated CS, 19 GA (PN 2671291301)
- One (1) welded slip tube, 12 inch x 20 inch, coated CS, 19 GA (PN 2671330901)
- One (1) welded slip tube, 12 inch x 39 inch, Coated CS, 19 GA (PN 2671331001)
- One (1) welded slip tube, 12 inch x 8 inch, coated CS, 19 GA (PN 2561330701)
- Three (3) 12 inch slip tube ring seal (PN 26713203)
- One (1) 12 inch Conair flange to 12 inch adapter (PN 18477902)
- Nine (9) 12 inch bolted pull ring, galvanized (PN 2671350301)
- Six (6) 12 inch U-shaped gasket, 19 GA (PN 2671360301)
- Two (2) 12 inch hose connection, coated CS, 19 GA (PN 2671400301)
- One (1) 12 inch Conair hard pipe gasket (PN 185107916)
- Six (6) 12 inch insulation (PN 25902418)
- Two (2) 12 inch hose, high temp (PN 2400071102)
- Four (4) 12 inch hose clamps (PN 24900126)
- One (1) 12 inch 90° insulation (PN 18195702)
- Twenty-four (24) 5/16-18NC x 1 inch hex head wiz lock cap screw (PN 21202504)
- Twenty-four (24) 516-18 hex head wiz lock nut (PN 22300804)
- Twenty-five (25) feet of 3 inch ASJ SSL insulation tape (PN 25910404)
- One (1) 8 inch hard pipe flange x 12 inch tubing adaptor (PN 1847791001)

# Preparing for installation

Your plant layout and drying system component positioning will determine the organization of pieces necessary to complete the piping between the dryer and hopper. Each application will vary. Conair recommends that you take the following steps before starting installation.

For more information about adding a Conair Hard Pipe Kit to your drying system, contact Conair.

Conair's sales number is 724-584-5500.

Conair's Instant Access 24/7 Parts and Service number is 800-458-1960. Outside the U.S., dial 814-437-6861.

**1 Organize all like pieces.** Place all clamps together, all straight sections together, all elbows together, etc.

**2 Start by laying the pieces out between the dryer and the hopper.** If you ordered your hard pipe kit as part of a Conair system, a system drawing may have been included that will indicate pipe position and suggested layout.



**3 Visually inspect to make sure that the pieces you have will meet the needs of your system.** If it looks like you will need additional pieces to complete your system, contact Conair Parts and Service. You can order individual pieces as necessary to complete your system.



**4 If your drying system has been in use, wait until all components have cooled prior to attempting any installation steps.**



**CAUTION: Hot surfaces.** Always protect yourself from hot surfaces inside and outside the dryer and drying hopper.

# Using Pull Ring Connections

The following are general usage instructions for pull-ring connections with U-shaped seals. This is the primary style of connection used with Conair hard pipe kits.

**1 Pull the U-shaped seal around one of the pipe flanges.** The seal can be stretched to fit, but avoid overstretching.

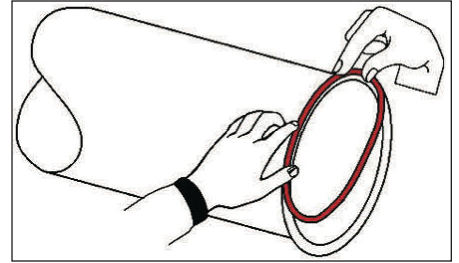

**2 Make sure that the “tooth” side of the U-shaped seal will face the pipe section that will be connected to this one.**

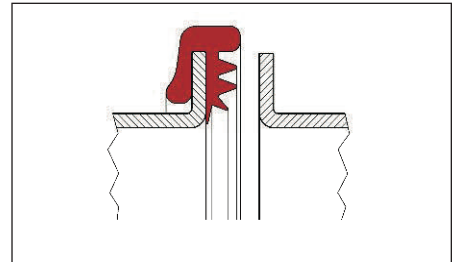

**3 Place the next section (counter-pipe) into position and push one half of the clamping ring onto the pipe flange.** Make sure that the pipes are aligned squarely and that the seals are not displaced.

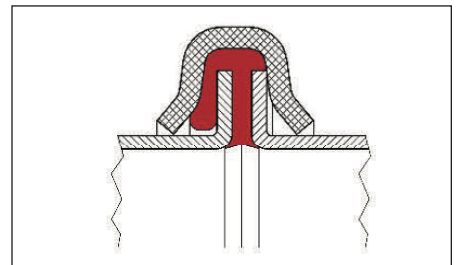

**4 Completely separate the two sections of the pull ring to be used.**

**5 Connect the two sections of the pull ring around the flange, loosely tighten using the bolts using your fingers.** Make sure that the pull ring is aligned around the entire flange. Make sure that the u-shaped seal is aligned and not protruding from the pull ring in any location.

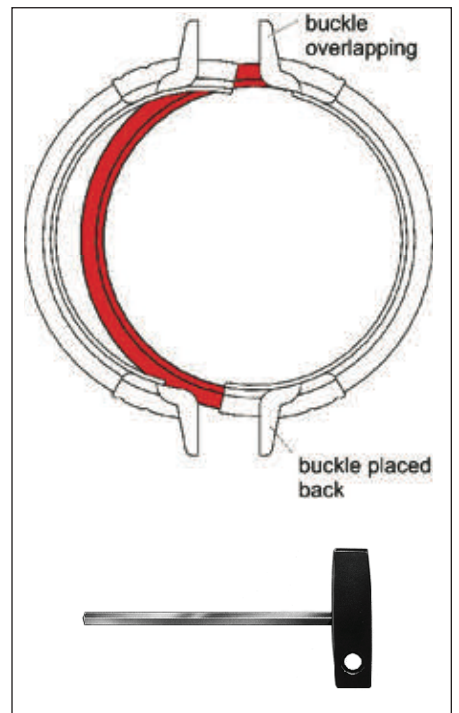

**6 Tighten, alternating from one bolt to the other, the bolts to clamp the pull ring around the flange.** Use a 6 mm hexagon screwdriver and tighten the bolt to a maximum torque of 25 Nm.

# Using Slip Tubes

Slip tubes can be used to achieve specific lengths of pipe without having to cut, weld, or flange additional piping.

**NOTE:** Slip tube connections must be secured against displacement. For horizontally installed tubing, tubes must be supported in the area of the slip connection to prevent sagging. The weight of the vertical runs should also be supported at the first available horizontal location, to keep joints from displacing in vertical runs.

**IMPORTANT:** Slip tubes are not meant to be used as telescoping tubes. They are not designed to be adjusted during operation.

To order a slip tube or other parts for your hard pipe kit, Conair's Instant Access 24/7 Parts and Service number is 800-458-1960. Outside the U.S., dial 814-437-6861.

## 1 Roll the ring seal onto the slip tube.

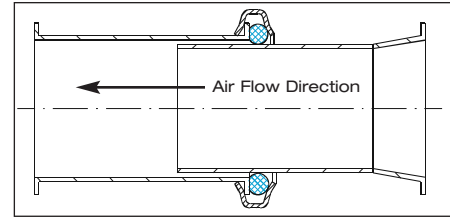

## 2 Slide the standard tube into the slip tube to the desired length.



**NOTE:** The slip tube overlap must be at least 1.79 inches {45.5 mm} and at least 1.77 inches {45.0 mm} of the tube must be above the flange for proper operation. If ordering a slip tube to fit into your hard pipe kit, be sure to order a length that accommodates these allowances. For example: do not order an 8 inch slip tube for a 7 inch gap, because the overlap will not be great enough.

## 3 Roll the ring seal back to the flange and secure with a pull ring.

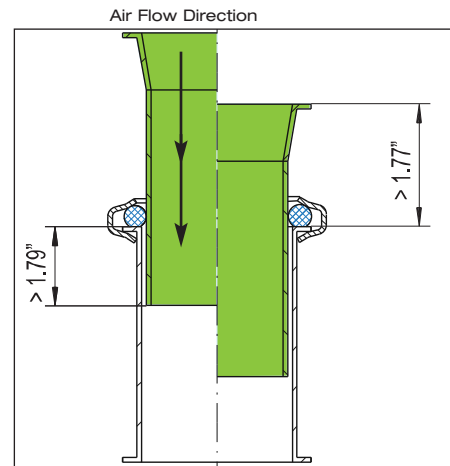

**4 Tighten, alternating from one bolt (side) to the other, the bolts to clamp the pull ring around the flange.** Use a 6 mm hexagon screwdriver and tighten the bolt to a maximum torque of 25 Nm.



# Attaching flange to top of dryer



**CAUTION: Hot surfaces.** Always protect yourself from hot surfaces inside and outside the dryer and drying hopper.



**NOTE:** Depending on your dryer model and the hard pipe kit that you ordered, this flange may already have been attached to your dryer.

Your hard pipe kit a Conair flange adapter. This adapter must be attached to the dryer prior to assembling the rest of the hard pipe system.

**1** If adding the hard pipe kit to an existing drying system, **remove the flexible hose from the dryer inlet and outlet.** Make sure that the dryer inlet and outlet are clean and ready for installation of the flange adapter(s).

**2** Locate the Conair flange adapter and hard pipe gasket.

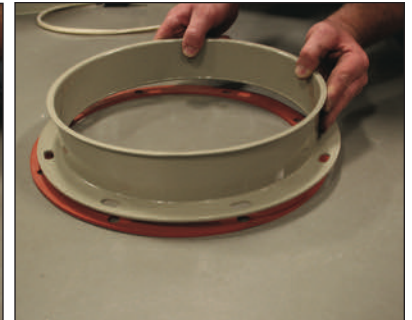

**3** Using the included hardware, attach the Conair flange adapter to the dryer outlet.

**4** Place the “U” seal on the top of the flange adapter.

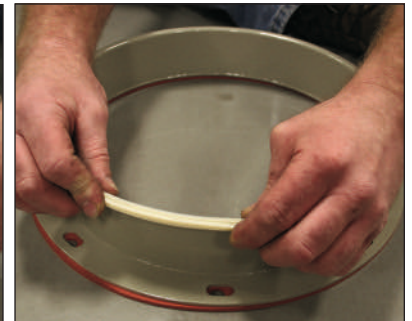
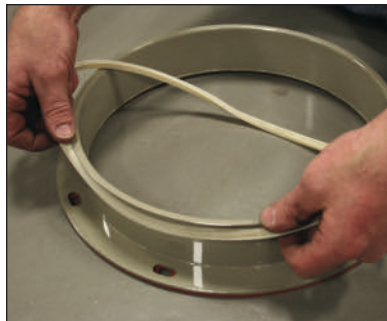

**5** Place the next pipe section on the top of the flange adapter.

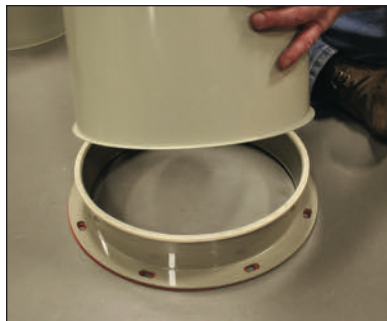

**6** Use the bolted pull ring to connect the pipe section to the flange adapter.

**7** Tighten the bolted pull ring bolt to a maximum torque of 25 Nm.



# Adding Turns/Bends

To order a slip tube or other parts for your hard pipe kit, Conair's Instant Access 24/7 Parts and Service number is 800-458-1960. Outside the U.S., dial 814-437-6861.

Once you have assembled your verticle section above the dryer, you will need to add the 90° bend to continue horizontally. A slip tube may need to be used as part of the last section before the turn to horizontal to fit your plant/system layout. *Refer to Using Slip Tubes earlier in these instructions* for more information about using slip tubes for more flexibility with your hard pipe kit.

- 1 Verify that when you add your bend or turn, you will be at your desired height for the horizontal run of your hard piping.** It may be necessary to utilize a slip tube to complete your vertical pipe section at the correct height.



- 2 Place the u-shaped gasket seal on the top of the pipe end.**



- 3 Place the bend on top of the pipe end.**

- 4 Use the bolted ring to connect the bend to the pipe.**

- 5 Tighten the bolted pull ring bolt to a maximum torque of 25 Nm.** Be sure to alternate tightening bolts from one side to another so that the pull ring clamps securely and evenly around the pipe flange.



**NOTE:** Slip tube connections must be secured against displacement. For horizontally installed tubing, tubes must be supported in the area of the slip connection to prevent sagging.



**IMPORTANT:** Slip tubes are not meant to be used as telescoping tubes. They are not designed to be adjusted during operation.

## Optional VFD Velocity Meter tubing (required for VFD operation)

The velocity meter requires a special section of hard pipe, with a tapped fitting location for the velocity meter installation. The compression fitting allows the velocity sensor to be oriented such that the hole (noted by a mark on the sensor) can be positioned to face the air-flow, and adjusted such that the depth of sensor hole is located in the center of the air flow in the piping.

The section of tubing with the velocity meter tap should be located about 10x the tube diameter (80 inches for 8-inch tubing) of straight pipe (after a bend) on the return line before the dryer. Due to velocity meter cable length and tubing runs, the best location is typically as close to the “Return air” inlet of the dryer on the return air tubing as possible. This typically gives the maximum straight run of tubing prior to the velocity meter location.



# Proper Location and use of Hanger, Clamp, and All-thread

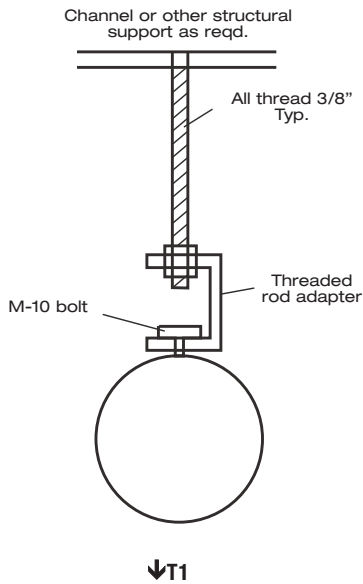

Your Conair Hard Pipe Kit comes with a quantity of tubing hangers (varies depending on which kit you order) for supporting the weight of the horizontal and vertical spans, specifically spans that use slip tube sections. A hanger should be placed on either side of any location where a slip tube was used. This includes supporting a vertical section where a slip tube was used by utilizing a hanger at the closest horizontal location to support the vertical section.

Proper hanging method uses:

- Ceiling mount clamp with rubber insert
- Threaded rod adapter
- M-10 bolt
- Proper length of all-thread - 3/8" tip and proper connection to approved load carrying structure

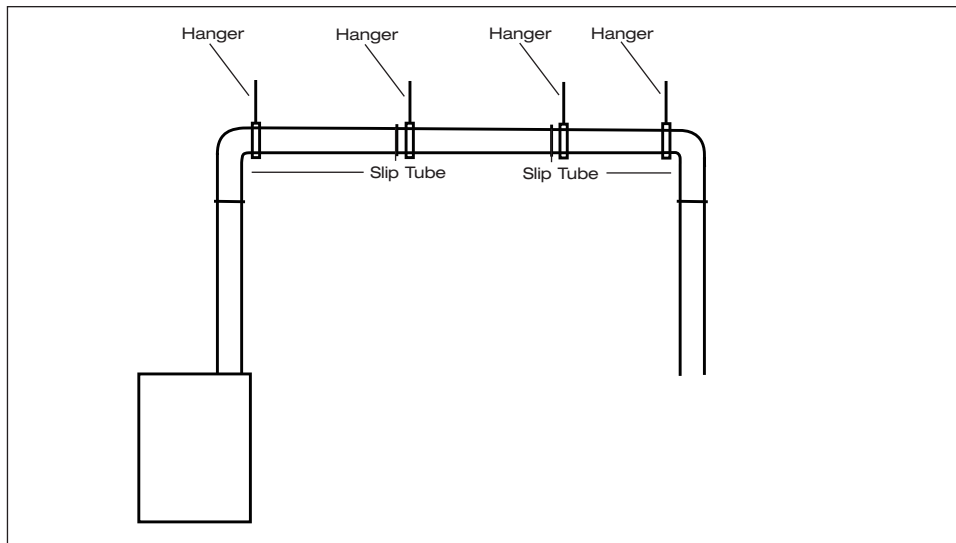

**NOTE:** T1 ✕ 440 lbs. {195.58 kg} at 0.2 in. {5.08 mm} deflection.

**NOTE:** Always follow all local and regional building codes when installing.

**NOTE:** Conair recommends the use of hangers at 10 ft. {3.05 m} intervals at minimum for appropriate support.

