

USER GUIDE
UGD041-1216

EnergySmart® Dryer

W Series Models 600 through 5000 with TouchView™ Technology (Allen-Bradley)



Please record your equipment's model and serial number(s) and the date you received it in the spaces provided.

Conair recommends recording the model and serial number(s) of your equipment and the date you received it in the User Guide. Our service department uses this information, along with the manual number, to provide help for the specific equipment you installed.

Please keep this User Guide and all manuals, engineering prints and parts lists together for documentation of your equipment.



NOTE: The software, firmware and application file information for your specific EnergySmart Dryer System is contained on a serial tag that was attached to the inside of the EnergySmart Dryer's control panel during assembly.

Date: _____

Manual Number: UGD0041-1216 _____

Serial Number(s): _____

Model Number(s): _____

Software Version(s): _____

Panelview Plus Operator Interface Terminal

Firmware Version Number: _____

Application File Name: _____

Programmable Logic Controller: _____

Firmware Version Number: _____

Application File Name: _____

DISCLAIMER: Conair shall not be liable for errors contained in this User Guide or for incidental, consequential damages in connection with the furnishing, performance or use of this information. Conair makes no warranty of any kind with regard to this information, including, but not limited to the implied warranties of merchantability and fitness for a particular purpose.

Table of Contents

1-1 Introduction

Purpose of the user guide	1-2
How the guide is organized	1-2
Using the EnergySmart Dryer with your system	1-3
Your responsibilities as a user	1-3
ATTENTION: Read this so no one gets hurt	1-4
How to use the lockout device	1-6

2-1 Description

What is the EnergySmart Dryer System?	2-2
Typical applications	2-2
How the EnergySmart Dryer System works	2-3
Specifications: EnergySmart Carousel Plus W Series	
Dehumidifying Dryers	2-4
Hopper Temperature Controller (HTC)	2-5
GasTrac (CGT) Process Air Heater	2-6
Dust Collectors	2-7
Positive Displacement (PD) Pumps	2-8
CH Series Insulated Hoppers	2-9
Drying Monitor, DM-II Model	2-12
EnergySmart Dryer control options	2-13

3-1 Installation

Installation - General	3-5
Unpacking the EnergySmart Dryer System components	3-6
Preparing for installation	3-7

Positioning the CH hopper floor stand	3-8
Installation of the HTC control	
(Model HTC 30, 60 and 90)	3-9
(Model HTC 120)	3-10
(Model HTC 180 and 270)	3-10
Location and mounting of the HTC heater assembly	
(Model HTC 30, 60 and 90)	3-11
(Model HTC 120)	3-11
(Model HTC 180 and 270)	3-11
Installing the CH hopper cone section	3-12
Installing the CH hopper door, upper and lid sections	3-13
Installing the cyclone (optional)	3-17
Installing the drying monitor probe	3-22
Installing the receiver(s) (optional)	2-25
Installing the purge valve(s) (optional)	3-25
Installing the modular distribution box(es) (optional)	3-25
Securing the CH hopper to the floor	3-26
Location and mounting of the GasTrac heater	3-27
Location and mounting of the dust collector (optional)	3-28
Location and mounting of the vacuum pump(s)	
and dust collector(s) (optional)	3-30
Positioning the dryer on the floor	3-31
Removing the cable tie from the desiccant wheel	
(W600-1000 models)	3-31
Installing the regeneration exhaust cover	3-31
Installing the return air inlet and air outlet adapters	
(W1600-5000 models)	3-33
Installing the overhead process air duct	
(W3200-5000 models)	3-34

Installation - Piping/Hoses	3-35
Optional hard piping kits	3-36
Connecting the heat sources	3-37
Hopper Temperature Controller (HTC) as heat source	3-37
GasTrac as heat source	3-38
Connecting the dryer to the heat source	3-39
Connecting the dust collector (optional).	3-40
Connecting the cyclone separator (optional)	3-41
Installing the Dwyer 641 air velocity transmitter	3-42
Installing the level switch (optional).	3-44
Adjusting the level sensor (optional)	3-45
Installing the process protection RTD sensor.	3-46
Location of the process material temperature probe (RTD)	3-47
Installing the GasTrac RTD sensor	3-48
Installing the return air dew point line	3-49
Installation - Main Power Connections	3-51
Connecting main power to the dryer	3-52
Connecting main power to the HTC	
(Model HTCs 30, 60, 90 and 120)	3-53
(Model HTCs 180 and 270)	3-54
Connecting main power to the GasTrac.	3-56
Connecting main power to the vacuum pump(s) (optional)	3-57
Connecting main power to the dust collector(s) (optional)	3-57
Installation - Conveying Lines	3-59
Connecting the conveying lines to the receiver(s) (optional).	3-60
Connecting the conveying lines to the purge valve(s) (optional)	3-60
Connecting the conveying lines to the vacuum pump(s) and	
dust collector(s) (optional)	3-61
Installation - Water Lines	3-63
Typical water lines installation drawing.	3-64

Connecting the aftercooler/intercooler and optional precooler (W600-1000)	3-65
Connecting the aftercooler/intercooler and optional precooler (W1600-5000)	3-66
Installation - Control and Communications Wiring	3-67
Connecting the HTC to the HTC controller	3-68
Connecting the RTD sensors (HTC only)	3-70
Connecting the GasTrac RTD sensors	3-72
Connecting the drying monitor probe to the dryer	3-73
Connecting the receiver to the level switch (optional)	3-74
Connecting the EnergySmart Dryer control to system components	3-75
Installation - Compressed Air Lines	3-85
Connecting the compressed air lines (optional)	3-86
Installation - Gas Piping and Exhaust Flue	3-87
Typical gas line installation drawing	3-88
Installing the Conair GasTrac	3-89
Connecting the gas and the exhaust flue to the GasTrac	3-92
Installation - Testing	3-95
Checking for proper air flow	3-96
Testing the variable frequency drive (VFD)	3-99
Testing the installation of the HTC	3-100
Checking the gas and electrical systems of the GasTrac	3-102
Testing the installation of the GasTrac	3-103
Testing the primary receiver (optional)	3-105
Testing the secondary receiver (optional)	3-107
Configuring the Dwyer 641 air velocity transmitter	3-109
Configuring the DM-II drying monitor	3-110
Configuring the level switch (optional)	3-110
Using communications (optional)	3-113

4-1 Operation

The EnergySmart Dryer System control panel	4-2
How to navigate the control screens	4-3
Control function flow charts	4-6
Login flow chart	4-6
Operation flow chart 1	4-7
Operation flow chart 2	4-8
Operation flow chart 3	4-9
Setup flow chart 1	4-10
Equipment setup flow chart 1	4-11
Equipment setup flow chart 2	4-12
Communications setup flow chart	4-13
Example setpoint change	4-14
Control function descriptions	4-15
EnergySmart Dryer System security levels	4-54
EnergySmart Dryer System Modbus communications	4-56
Starting the EnergySmart Dryer System (Without OptiMizer™ mode)	4-58
Adjusting the EnergySmart Dryer System (Without OptiMizer™ mode)	4-62
Starting the EnergySmart Dryer System (With OptiMizer™ mode).	4-67
Stopping the EnergySmart Dryer System.	4-71
Using dryer recipes (optional)	4-74
Copying files from the EnergySmart Dryer System	4-80
Using Dewpoint.	4-84
Using OptiMizer™.	4-85

5-1 Maintenance

Preventative maintenance checklist	5-2
Inspecting the hoses, piping and gaskets	5-8
Cleaning the CH hopper	5-9
Maintaining the Dwyer 641 air velocity transmitter	5-10
Cleaning the combustion filter of the GasTrac	5-11
Cleaning the electrical enclosure filter of the GasTrac	5-12
Replacing the spark igniter of the GasTrac	5-13
Cleaning the ultraviolet flame detector of the GasTrac	5-15
Cleaning the process filter	5-17
Cleaning the regeneration filter	5-18
Cleaning the aftercooler/intercooler coils	5-19
Cleaning the volatile trap on the demister (W600-1000)	5-21
Cleaning the volatile trap on the demister (W1600-5000)	5-22
Cleaning the precool coils (optional)	5-23
Replacing the regeneration heater (W600-1000)	5-24
(W1600-2400)	5-26
(W3200-5000)	5-28
Checking dew point	5-30
Cleaning the dust collector (optional)	5-32
Cleaning the cyclone separator (optional)	5-32

6-1 Troubleshooting

Before beginning	6-2
A few words of caution	6-3

DIAGNOSTICS

How to identify the cause of a problem 6-4
Shutdown alarms 6-7
Passive alarms 6-14
Dew point troubleshooting..... 6-28
Poor material drying troubleshooting..... 6-29

REPAIR

Replacing fuses..... 6-34
Checking heater solid state relays..... 6-35
Checking or replacing temperature sensors 6-36
Replacing the desiccant wheel assembly (W600-1000)..... 6-37
Replacing the desiccant wheel motor (W600-1000) 6-39
Replacing the desiccant wheel motor (W600-1000) 6-40

A Appendix

We're here to help A-1
How to contact customer service A-1
Before you call... A-1
Equipment guarantee A-2
Performance warranty A-2
Warranty limitations A-2
Conair print numbers list A-3

Introduction

Purpose of the user guide.	1-2
How the guide is organized.	1-2
Using the EnergySmart Dryer	
with your system.	1-3
Your responsibilities as a user.	1-3
ATTENTION:	
Read this so no one gets hurt	1-4
How to use the lockout device.	1-6

Purpose of the User Guide

This User Guide describes the Conair EnergySmart® Dryer System with TouchView™ Technology and explains step-by-step how to install, operate, maintain and repair this equipment.

Before installing this product, please take a few moments to read the User Guide and review the diagrams and safety information in the instruction packet. You also should review manuals covering associated equipment in your system. This review won't take long, and it could save you valuable installation and operating time later.

How the Guide is Organized

Symbols have been used to help organize the User Guide and call your attention to important information regarding safe installation and operation.



Symbols within triangles warn of conditions that could be hazardous to users or could damage equipment. Read and take precautions before proceeding.



Numbers indicate tasks or steps to be performed by the user.



A diamond indicates the equipment's response to an action performed by the user.



An open box marks items in a checklist.



A circle marks items in a list.



Indicates a tip. A tip is used to provide you with a suggestion that will help you with the maintenance and the operation of this equipment.



Indicates a note. A note is used to provide additional information about the steps you are following throughout the manual.

Using the EnergySmart Dryer with Your System

The Conair EnergySmart® Dryer with TouchView™ Technology used within your system is factory configured to be used as a central dryer only. Therefore, this manual incorporates the information necessary to use these dryers for central drying applications.

Your Responsibility as a User

You must be familiar with all safety procedures concerning installation, operation and maintenance of this equipment. Responsible safety procedures include:

- Thorough review of this User Guide, paying particular attention to hazard warnings, appendices and related diagrams.
- Thorough review of the equipment itself, with careful attention to voltage sources, intended use and warning labels.
- Thorough review of instruction manuals for associated equipment.
- Step-by-step adherence to instructions outlined in this User Guide.



NOTE: Dryers can be used for various applications.

ATTENTION:

Read this so no one gets hurt

We design equipment with the user's safety in mind. You can avoid the potential hazards identified within this system by following the procedures outlined below and elsewhere in the User Guide.



WARNING: Improper installation, operation or servicing may result in equipment damage or personal injury.

This equipment should be installed, adjusted and serviced by qualified technicians who are familiar with the construction, operation and potential hazards of this type of machinery.

All wiring, disconnects and fuses should be installed by qualified electrical technicians in accordance with electrical codes in your region. Always maintain a safe ground. Do not operate the equipment at power levels other than what is specified on the machine serial tag and data plate.



WARNING: Voltage hazard

This equipment is powered by three-phase alternating current, as specified on the equipment's serial tags and data plates. Reference optional additional equipment's manuals for their power requirements.

A properly-sized conductive ground wire from the incoming power supply must be connected to the chassis ground terminal inside the electrical enclosure. Improper grounding can result in severe personal injury and erratic machine operation.

Always disconnect and lock out the incoming main power source before opening the electrical enclosure or performing non-standard operating procedures, such as routine maintenance. Only qualified personnel should perform troubleshooting procedures that require access to the electrical enclosure while power is on.

ATTENTION:

Read this so no one gets hurt (continued)

We design equipment with the user's safety in mind. You can avoid the potential hazards identified within this system by following the procedures outlined below and elsewhere in the User Guide.



CAUTION: Hot Surfaces.

Always protect yourself from hot surfaces inside the dryer and hopper. Also exercise caution around exterior surfaces that may become hot during use. These include the hopper door frame, the exterior of an uninsulated hopper, the return air hose and the dryer's process filter housing and exhaust outlet and the Hopper Temperature Controller (HTC) or GasTrac Dryer (CGT).



WARNING: Do not place aerosol, compressed gas or flammable materials on or near this equipment.

The hot temperatures associated with the drying process may cause aerosols or other flammable materials placed on the dryer or hopper to explode.

How to Use the Lockout Device

 **CAUTION:** Before performing maintenance or repairs on this product, you should disconnect and lockout electrical power sources to prevent injury from unexpected energization or start-up. A lockable device has been provided to isolate this product from potentially hazardous electricity.

Lockout is the preferred method of isolating machines or equipment from energy sources. Your Conair product is equipped with the lockout device pictured below.

To use the lockout device:

- 1 Stop or turn off the equipment.**
- 2 Isolate the equipment from the electric power.** Turn the rotary disconnect switch to the OFF, or “O” position.
- 3 Secure the device with an assigned lock or tag.** Insert a lock or tag in the holes to prevent movement.
- 4 The equipment is now locked out.**



WARNING: Before removing lockout devices and returning switches to the ON position, make sure that all personnel are clear of the machine, tools have been removed and all safety guards reinstalled.

To restore power, turn the rotary disconnect back to the ON position:

- 1 Remove the lock or tag.**
- 2 Turn the rotary disconnect switch to the ON or “I” position.**

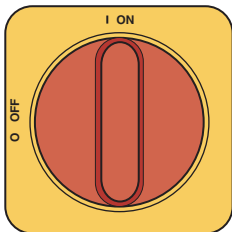
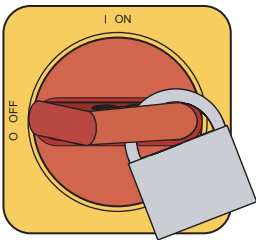
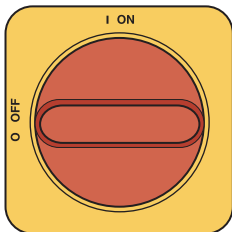

Description

What is the EnergySmart Dryer System?	2-2
Typical applications	2-2
How the EnergySmart Dryer System works . . .	2-3
Specifications: EnergySmart Carousel	
Plus W Series Dehumidifying Dryers	2-4
Hopper Temperature Controller (HTC) . . .	2-5
GasTrac (CGT) Process Air Heater	2-6
Dust Collectors	2-7
Positive Displacement (PD) Pumps	2-8
CH Series Insulated Hoppers	2-9
Drying Monitor, DM-II Model	2-12
EnergySmart Dryer control options	2-13

What is the EnergySmart® Dryer System?

 **NOTE:** The EnergySmart® W600 - 5000 dryer provides no heat to the process air. A separate heat source is required at the hopper inlet to heat the air to the required drying temperature.

Energy efficient drying and superior end product are the results of having precise control of your drying process. The EnergySmart Dryer System control allows you to optimize your system settings to achieve consistent drying results that boost your plant-wide efficiency and produce high quality final product. An OptiMizer™ Mode automatically adjusts the air flow and temperature of your process for maximum system efficiency.

The EnergySmart Dryer System could include:

- EnergySmart Dryer with TouchView™ Technology (Allen-Bradley control)
- CH Hopper with an integrated cyclone - optional
- Heater (gas or electric)
- Dust collector(s) - optional
- Patented DM-II drying monitor technology
- Receiver(s) - optional
- Vacuum pump(s) - optional
- Audible alarm

Typical Applications

- 1** Dryer on the floor, a single CH Hopper with a Hopper Temperature Controller (HTC) or GasTrac Dryer (CGT) package on a floor stand.

The EnergySmart Dryer System can be used successfully in applications that require:

- A contamination-free drying environment
- A constant flow of dehumidified air
- Throughput rates of 400 to 5,000 lbs { 181 to 2,268 kg } per hour (some materials can be run at higher rates).
- Dew points of -40°F {-40°C}.

How the EnergySmart Dryer System Works

The drying circuit is a traditional desiccant drying system. The dryer supplies low dew point air that has passed through a heater (HTC or GasTrac) into the bottom of a CH Hopper. The air moves up through the hopper picking up moisture from the material as it transfers its heat into the material. Once the air is at the top of the hopper, it returns to the dryer after passing through optional filtration to remove fines. Once in the dryer, the air is cooled by passing through a cooling coil to lower the temperature so that the air can be dried as it passes through the desiccant where the moisture is absorbed.

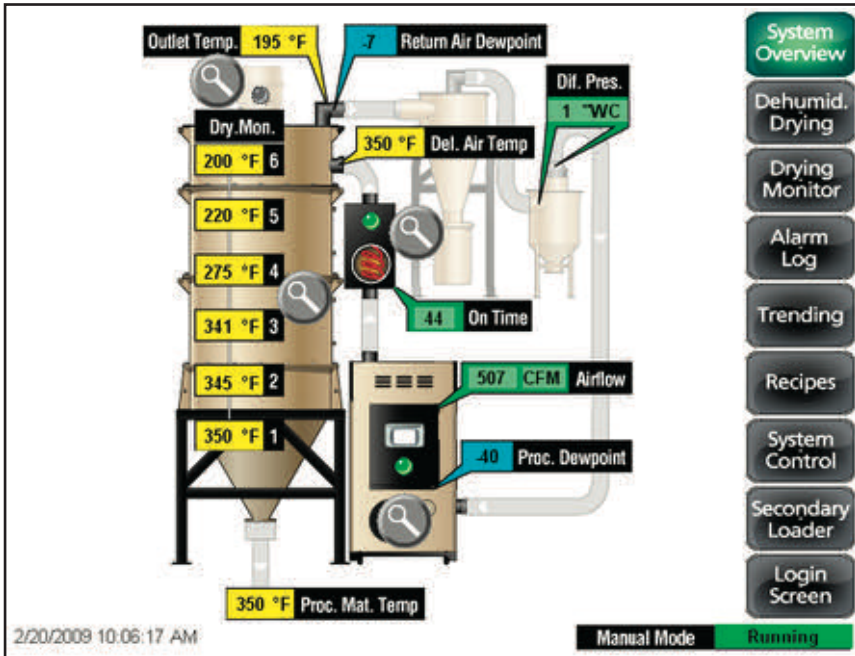

Specifications: EnergySmart Carousel Plus W Series Dehumidifying Dryers

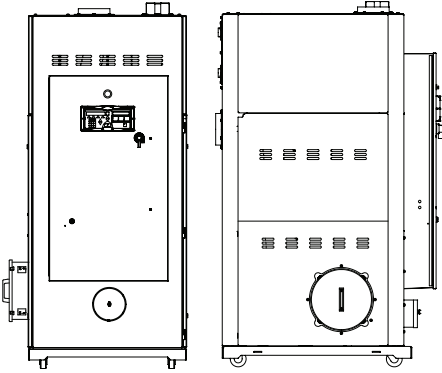

APPLICATION NOTES:

All dryers are supplied with an aftercooler/intercooler as standard. The aftercooler/intercooler reduces the temperature of the return air from the drying hopper, improving the efficiency of the desiccant. The aftercooler/intercooler must be connected with the proper water flow rate and temperature to attain the rated throughput.

When to use central models

Models W600 - W5000 of Carousel Plus dryers are all configured as central dryers. Central dryers do not have process heaters. These models should be used when drying multiple materials that require different drying temperatures. Central models dehumidify the process air, which is then heated to the correct set-point by a Hopper Temperature Controller (HTC) or GasTrac Dryer (CGT).

When to use additional filtration

The standard return air cartridge filter is sized for the airflow of each dryer model and is suited for most applications. You should consider adding an optional dust collector and/or volatile trap if:

- The material contains excessive fines. An additional dust collector or cyclone will extend time between filter cleaning.
- The material produces volatiles during drying which condense into a waxy or oily residue. A volatile trap will help to protect the desiccant.

MODELS	W600*	W800*	W1000*	W1300*	W1600*	W2000*	W2400*	W3200*	W4000*	W5000*
Performance characteristics (with full hopper)										
Drying temperature	All models 100° - 375°F (38° - 191°C) with options									
Dew point	All models -40°F (-40°C)									
Dimensions inches (cm)										
A - Height	93.8 (238.3)			92.2 (134.2)			98.3 (249.7)			
B - Width	49.3 (125.2)			53.9 (136.9)			58.2 (147.8)			
C - Depth	72.4 (183.9)			106.6 (270.8)			123.6 (313.9)			
Outlet/inlet hose diameter	8.0 (20.3)			12.0 (30.5)			12.0 (30.5)			
Approximate weight lbs (kg)										
Installed	1300 (590)	1300 (590)	1400 (636)	1600 (726)			2000 (907)			
Shipping	1495 (678)	1495 (678)	1515 (687)	2620 (1188)			3385 (1535)			
Voltage - Standard/Central Full load amps†										
400 V/3 phase/50 Hz‡	89.2 / 34.3	89.2 / 34.3	116.6 / 34.2	152.7 / 42.9	159.4 / 49.6	194.1 / 56.8	221.7 / 57.0	282.7 / 90.5	317.0 / 97.7	371.9 / 97.4
460 V/3 phase/60 Hz	77.6 / 29.8	77.6 / 29.8	101.5 / 29.8	133.4 / 37.8	138.6 / 43.0	168.9 / 49.4	192.8 / 49.4	247.3 / 80.0	275.9 / 84.7	323.7 / 84.7
575 V/3 phase/60 Hz	62.1 / 23.9	62.1 / 23.9	81.1 / 23.8	106.6 / 30.2	110.8 / 34.4	135.1 / 39.6	154.2 / 39.6	197.7 / 64.0	220.6 / 67.8	258.7 / 67.7
380 V/3 phase/60 Hz‡‡	93.9 / 36.1	93.9 / 36.1	122.7 / 36.0	160.7 / 45.2	167.8 / 52.2	204.3 / 59.8	233.4 / 60.0	297.6 / 95.3	333.7 / 102.8	391.5 / 102.5
Total kilowatts§ kW (BTU/min)	53 (3017) / 15 (854)	53 (3017) / 15 (854)	72 (4098) / 15 (584)	95 (5407) / 19 (1081)	95 (5407) / 19 (1081)	114 (6489) / 19 (1081)	133 (7570) / 19 (1081)	152 (8652) / 38 (2157)	190 (10809) / 38 (2157)	228 (12972) / 38 (2157)
Water requirements (for aftercooler/intercooler or optional precooler)**										
Recommended temperature††	45° - 85°F (7° - 29°C)			45° - 85°F (7° - 29°C)			45° - 85°F (7° - 29°C)			
Water flow gal./min. (liters/min.)	6 - 25 (22.7 - 94.6)			12 - 40 (45.4 - 151.4)			15 - 50 (56.8 - 189.3)			
Water connections	1 1/2 inch NPT			1 1/2 inch NPT			1 1/2 inch NPT			

SPECIFICATION NOTES:

* Dryers W600-W5000 that are central dryers do not have process heaters. Hopper Temperature Controllers (HTC's) or GasTrac Dryers (CGT's) are used at the hopper for heating the process air. See the Hopper Temperature Controller (HTC) and GasTrac Dryer (CGT) specification sheets for further technical information.

† Total amps listed apply to dryer only, see the Hopper Temperature Controller (HTC) or GasTrac (CGT) specification sheets for additional power requirements.

‡ Dryers running at 50 Hz will have 17% less airflow, and a 17% reduction in material throughput.

§ Total kW listed at a regeneration temperature of 350°F (177°C). The total kW listed reflects the kW of the dryer only. It does not include any external heat source, for example the Hopper Temperature Controller (HTC) or GasTrac Dryer (CGT).

** When drying below 150°F (66°C) a precooler is required.

†† Temperatures above or below the recommended levels may affect dryer performance. Tower, chiller or municipal water sources can be used.

‡‡ Not available in Allen Bradley models.

Specifications may change without notice. Consult a Conair sales representative for the most current information.

Specifications: Hopper Temperature Controller (HTC)

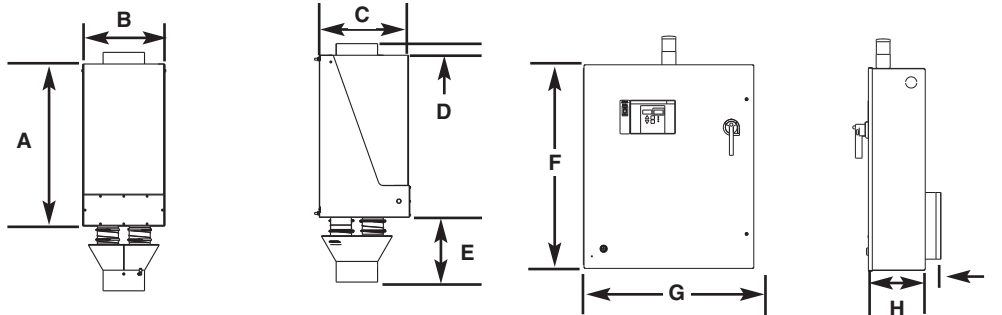

Description 2

MODEL HTC	HTC-30H*		HTC-60H*		HTC-90H*	HTC-120H*	HTC-180H*	HTC-270H*
Carousel Plus dryer model	W600		W800	W1000	W1600	W2400	W3200	W5000
Performance characteristics								
Temperature range	150° - 375° F {66° - 191° C}							
Flow rate cfm	300	400	500	800	1200	1600	2500	
Pressure drop@flow rate inches WC†	3.0	1.8	2.3	4.0	3.8	5.9	6.4	
{mm} WC†	{76.2}	{45.7}	{58.4}	{101.6}	{96.5}	{149.9}	{162.6}	
Dimensions inches {cm} and weight lb {kg}								
Heater box dimensions								
Inlet size (OD)	8	8	12	12	12	12	12	
Outlet size selection (OD)	8	8	12	12	12	12	12	
A - Height	31.4 {79.8}	27.5 {69.9}	27.0 {68.6}	31.0 {78.7}	34.0 {86.4}	36.4 {92.5}		
B - Width	10.1 {25.7}	13.6 {34.5}	16.0 {40.6}	16.0 {40.6}	18.0 {45.7}	24.2 {61.5}		
C - Depth	10.7 {27.2}	10.9 {27.7}	10.9 {27.7}	16.0 {40.6}	17.0 {43.2}	17.0 {43.2}		
D - Height of discharge nozzle above the heater box	1.75 {4.4}	1.5 {3.8}	2.0 {5.1}	2.0 {5.1}	2.0 {5.1}	2.0 {5.1}		
E - Height of inlet nozzle below the heater box	10.6 {26.9}	7.1 {18.0}	8.0 {20.3}	10.0 {25.4}	13.0 {33.0}	15.4 {39.1}		
Installed weight lb {kg}‡	38 {17}	37 {17}	78 {35}	93 {43}	102 {46}	131 {59}		
Control center dimensions								
Height - F	24.0 {61.0}	24.0 {61.0}	36.0 {91.4}	48.0 {122.0}	60.0 {152.4}	60.0 {152.4}		
Width - G	24.0 {61.0}	24.0 {61.0}	30.0 {76.2}	36.0 {91.4}	42.0 {106.7}	42.0 {106.7}		
Depth - H	10.0 {25.4}	10.0 {25.4}	10.0 {25.4}	10.0 {25.4}	12.0 {30.5}	12.0 {30.5}		
Clearance for heat sink - I	3.0 {7.6}	3.0 {7.6}	3.0 {7.6}	3.0 {7.6}	3.0 {7.6}	3.0 {7.6}		
Installed weight lb {kg}	150.0 {68.0}	150.0 {68.0}	180.0 {81.6}	250.0 {113.0}	consult Conair	consult Conair		
Voltage full load amps								
400 V/3 phase/50-60 Hz	44	87	131	175	261	381		
480 V/3 phase/50-60 Hz	38	76	114	152	227	340		
575 V/3 phase/50-60 Hz	30	61	91	122	182	272		

TPDS022-0808

SPECIFICATION NOTES:

- * The HTC model number reflects the kilowatts of each unit. For example, HTC-60 has a 60 kilowatt heater.
- † The unit of measure WC is water column.
- ‡ Weights are approximate.

Specifications may change without notice. Consult a Conair representative for the most current information.

Specifications: GasTrac (CGT) Process Air Heater

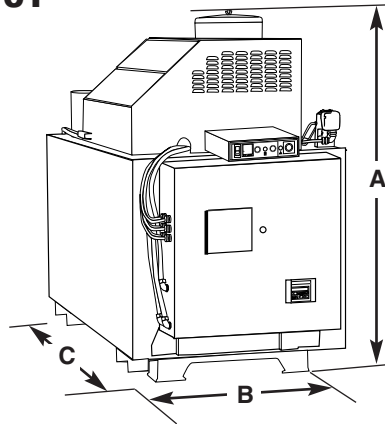

MODELS	CGT150	CGT250	CGT350	CGT500	CGT700
Performance characteristics					
Temperature range °F {°C}	250 - 350 {122 - 177}				
Maximum flue temperature °F {°C}	750 {399}				
Combustion blower	0.5 Hp peripheral	0.5 Hp peripheral	1 Hp peripheral	1 Hp peripheral	1 Hp peripheral
Ignition source	Spark igniter, interrupted				
Burner type	Metal-ceramic				
Minimum burner capacity BTU/hr	40,000	75,000	90,000	125,000	150,000
Maximum burner capacity BTU/hr	150,000	225,000	350,000	500,000	700,000
Gas consumption*					
CFH @250°F {L/hour}	50 {1416}	90 {2549}	105 {2973}	150 {4248}	230 {6513}
CFH @350°F {L/hour}	140 {3964}	215 {6088}	325 {9203}	465 {13167}	675 {19114}
Gas pressure to regulator In. H ₂ O {kPa}	10 - 20 {2.49 - 4.98}				
Gas pressure from regulator In. H ₂ O {kPa}	4 - 7 {0.99 - 1.74}				
Gas heating rate BTU/ft ³	1000				
Dimensions in. {mm}					
A - Height	54 {1372}	61 {1549}	61 {1549}	61 {1549}	61 {1549}
B - Width	29 {737}	37 {940}	37 {940}	37 {940}	37 {940}
C - Length	66 {1676}	64 {1626}	74 {1880}	74 {1880}	74 {1880}
Air inlet/outlet, OD	8 {203}	8 {203}	8 {203}	8 {203}	12 {300}
Approximate weight lb {kg}					
Installed	600 {272}	600 {272}	600 {272}	600 {272}	600 {272}
Shipping	700 {317}	700 {317}	700 {317}	700 {317}	600 {272}
Voltage Total amps					
380V/3 phase/50Hz	3.0	3.0	1.6	1.3	3.0
415V/3 phase/50Hz	3.0	2.7	1.5	1.2	3.0
240V/3 phase/60Hz	3.0	4.8	2.5	2.0	3.0
480V/3 phase/60Hz	3.0	2.4	1.3	1.0	3.0
Emissions					All GasTrac components meet: UL372, UL795, FM, CGA, AGA, NFPA 54, NFPA 79, NFPA 86 and IAS
Primary excess air	10 - 30%	Carbon Monoxide (CO)	<10 ppm corrected to 3% O ₂		
Oxygen (O ₂) (ideal 3 - 4%)	2 - 5%	NOX	<20 ppm corrected to 3% O ₂		
Carbon Dioxide (CO ₂)	9 - 10.5%	Unburned hydrocarbons	<10 ppm corrected to 3% O ₂		

TPDS009-0408

SPECIFICATION NOTES:

* Designed for natural gas. For alternate fuel, contact your Conair representative.
Specifications may change without notice. Consult a Conair representative for the most current information.

Specifications: Dust Collectors

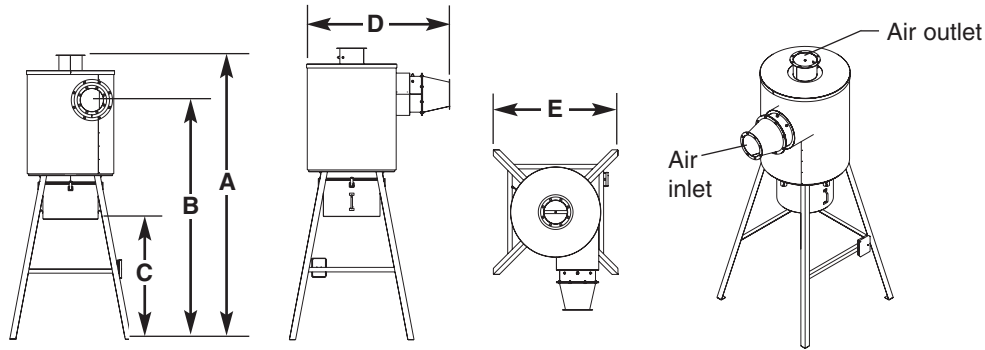

MODELS	18087803	18087801
Uninsulated or Insulated	Uninsulated	Insulated
Dimensions inches (cm)		
A - Height	96.5 {245}	96.5 {245}
B - Height to centerline	81.3 {207}	81.3 {207}
C - Clearance below canister	41.0 {104}	41.0 {104}
D - Depth	53.1 {135}	43.9 {112}
E - Width	42.2 {107}	42.2 {107}
Air inlet/outlet	8	12
Weight lb (kg)		
Installed	150 {68}	160 {73}
Shipping	180 {82}	190 {86}

SPECIFICATION NOTES:
Specifications can change without notice. Check with a Conair representative for the most current information.

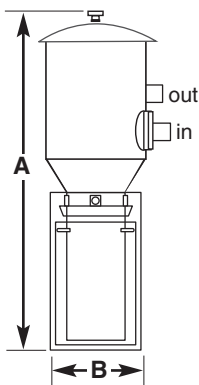

Model DC1 and DC2

MODELS	DC1	DC2
Performance Characteristics		
Pump size range Hp (kW) *	3-7.5 {2.2-5.6}	10-25 {7.5-18.7}
Vacuum line size OD in (mm)	1.5-2.5 {38.1-63.5}	2.25-4.0 {57.2-101.6}
Filter area ft ² {M ² }	42.8 {4.0}	100.3 {9.3}
Maximum collection capacity ft ³ {liters}	1.1 {31.1}	2.1 {59.4}
Recommended dust collection ft ³ {liters}	0.75 {21.2}	1.0 {28.3}
Dimensions inches (cm)		
A - Height	58.0 {147.3}	67.0 {170.1}
B - Width	15.0 {38.1}	19.0 {48.3}
Depth	20.0 {50.8}	19.0 {48.3}
Weight lb (kg)		
Installed	110 {50}	150 {68}
Shipping	140 {64}	280 {127}
Voltage total amps		
120V/1 phase/60Hz	1.0	1.0
Compressed air requirement		
80-120 psi {5.5-8.3 bars}		

SPECIFICATION NOTES:
* Model DC1 works with Conair pump models PSS3, PSS6, PD3, PD5, PD7.5. Model DC2 works with PSS11, PD10, PD15, PD25.
Specifications can change without notice. Check with a Conair representative for the most current information.

TPCS012-0408

Specifications: Positive Displacement (PD) Pumps

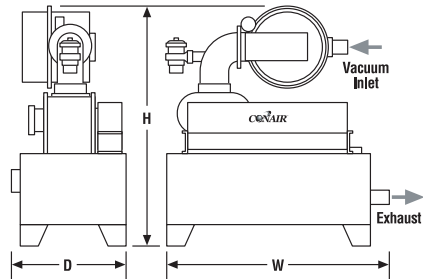

* Energy-saving, high efficiency motors are also available.

SPECIFICATION NOTES: Specifications can change without notice. Check with a Conair representative for the most current information.	MODELS	PD3	PD5	PD7.5	PD10	PD15	PD25
		Motor Type*	TEFC	TEFC	TEFC	TEFC	TEFC
	Performance						
	Horsepower	3	5	7.5	10	15	25
	Standard CFM at Material Pickup Point @ 10" Hg	52.6	76.6	121.2	154.5	201.1	346.2
	Average Sound Level (dbA) @ 8", 10" and 12" Hg	86	86.3	86	85.8	88.8	93
	Dimensions in. {mm}						
	Standard Inlet Size (OD)	1.5 {38}	1.75 {44}	2.25 {57}	2.5 {64}	3.0 {76}	4.0 {102}
	Exhaust Line Size (OD)	2.5 {64}	2.5 {64}	2.5 {64}	4.0 {102}	4.0 {102}	4.0 {102}
	Height (H)	37 {940}	37 {940}	41 {1041}	51 {1295}	51 {1295}	52 {1321}
	Width (W)	35 {889}	35 {889}	35 {889}	39.5 {1003}	39.5 {1003}	39.5 {1003}
	Depth (D)	27 {686}	27 {686}	27 {686}	33 {838}	33 {838}	34 {864}
	Installed Weight / lb {kg}	325 {147}	325 {147}	370 {168}	625 {283}	640 {290}	960 {435}
	Voltage Total Amps						
	240	7.6	12	18.8	28	39	59
	480	3.8	6	9.4	14	19.5	29.5
	575	2.9	4.8	7.5	10.7	16	27

SPECIFICATIONS FOR PUMPS WITH SOUND ENCLOSURES

Specifications not listed below are the same as those listed above. All Sound Enclosures include a cooling fan 115 VAC @ 2 amps.

MODELS	PD3	PD5	PD7.5	PD10	PD15	PD25	SUPER (ANY MODEL)
Performance							
Average Sound Level (dbA) @ 8", 10" and 12" Hg	61.9	69.8	76.2	79.3	86.0	90.0	Under 60 dbA
Enclosure Construction	Painted Steel			Natural Aluminum			Painted Steel
Allowance Space for Service Access / in	48 (Opposite Vacuum Inlet)			36 (Opposite Vacuum Inlet)			36 (Front, Next to Filter)
Dimensions in. {mm}							
Height (H)	49 {1245}			64 {1626}			96 {2438}
Width (W)	54 {1372}			55 {1397}			70 {1778}
Depth (D)	32 {813}			36 {914}			50 {1270}

TPCS026-0408

Specifications: CH Series Insulated Hoppers

Without Integrated Cyclone (Fig. 1)

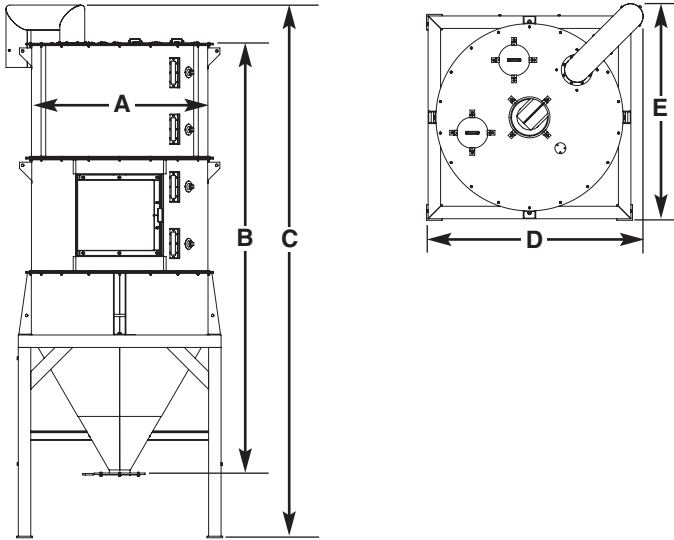

With Integrated Cyclone (Fig. 2)

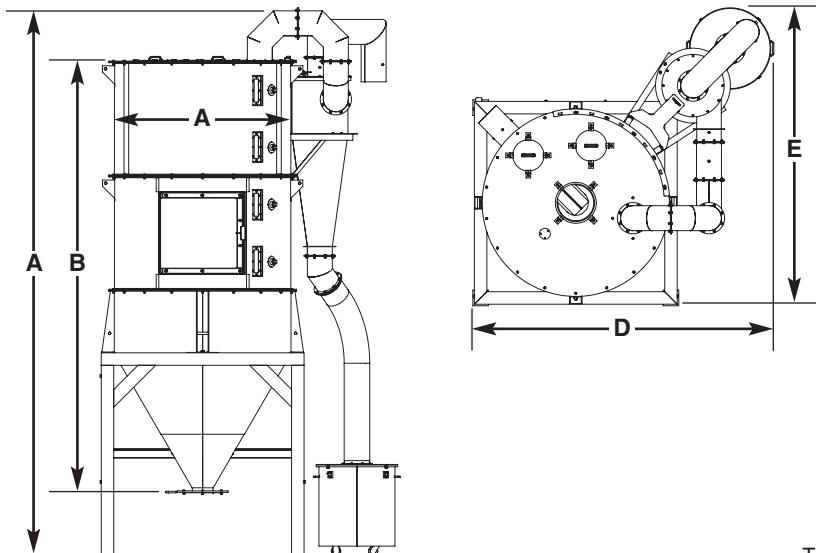

Specifications: CH Series Insulated Hoppers

Without Integrated Cyclone

MODEL	CH54-70	CH54-85	CH54-99	CH54-114	CH54-129	CH64-158	CH64-187	CH64-215	CH64-248
FIGURE NUMBER	Fig. 1	Fig. 1	Fig. 1	Fig. 1	Fig. 1	Fig. 1	Fig. 1	Fig. 1	Fig. 1
Performance characteristics									
Capacity ft ³ {liter}	70 {1982}	85 {2407}	99 {2804}	114 {3228}	129 {3653}	158 {4475}	187 {5296}	215 {6089}	248 {7023}
Capacity @ 35 lb/ft ³	2450	2975	3465	3990	4515	5530	6545	7525	8680
Dimensions inches {cm}									
A - Inside diameter	54 {137}	54 {137}	54 {137}	54 {137}	54 {137}	64 {163}	64 {162}	64 {162}	64 {163}
B - Hopper height	101.3 {257}	120.1 {305}	132.1 {336}	138.1 {351}	150.1 {381}	144.6 {367}	158.6 {403}	174.6 {443}	192.6 {489}
C - Overall height	136.8 {347}	154.8 {393}	166.8 {424}	170.8 {434}	182.8 {464}	177.9 {452}	189.9 {482}	207.9 {528}	225.9 {574}
D - Width	69.4 {176}	69.4 {176}	69.4 {176}	69.4 {176}	69.4 {176}	76.0 {193}	76.0 {193}	76.0 {193}	76.0 {193}
E - Depth	69.4 {176}	69.4 {176}	69.4 {176}	69.4 {176}	69.4 {176}	76.0 {193}	76.0 {193}	76.0 {193}	76.0 {193}
Air inlet (OD)	8 {20.3}					8 {20.3}			
Air outlet (OD)	8 {20.3}					8 {20.3}			
Material discharge (ID)	6 {15.2}					6 {15.2}			
Weights lb {kg}									
Installed weight (hopper only)	1100 {499}	1250 {567}	1450 {658}	1550 {703}	1650 {748}	1850 {839}	2050 {930}	2150 {975}	2250 {1021}
Mounting interfaces									
Hopper loader (Top)	IT07	IT07	IT07	IT07	IT07	IT07	IT07	IT07	IT07
Material discharge (Bottom)	IB03	IB09	IB09	IB09	IB09	IB09	IB09	IB09	IB09

Without Integrated Cyclone

MODEL	CH74-245	CH74-366	CH74-487	CH100-450	CH100-675	CH100-900
FIGURE NUMBER	Fig. 1	Fig. 1	Fig. 1	Fig. 1	Fig. 1	Fig. 1
Performance characteristics						
Capacity ft ³ {liter}	245 {6938}	366 {10365}	487 {13792}	450 {12743}	675 {19114}	900 {25485}
Capacity @ 35 lb/ft ³	8575	12810	17045	15750	23625	31500
Dimensions inches {cm}						
A - Inside diameter	74 {188}	74 {188}	74 {188}	100 {254}	100 {254}	100 {254}
B - Hopper height	170.2 {432}	218.2 {554}	266.2 {676}	199 {505}	249 {632}	297 {754}
C - Overall height	193.7 {492}	241.7 {614}	289.7 {736}	219 {556}	269 {683}	317 {805}
D - Width	90.5 {229.9}	90.5 {229.9}	90.5 {229.9}	120.0 {305}	120.0 {305}	120.0 {305}
E - Depth	90.5 {229.9}	90.5 {229.9}	90.5 {229.9}	120.0 {305}	120.0 {305}	120.0 {305}
Air inlet (OD)	12 {30.5}			12 {30.5}		
Air outlet (OD)	12 {30.5}			12 {30.5}		
Material discharge (ID)	8 {20.3}			11.875 {30.2}		
Approximate weight lb {kg}						
Installed weight (hopper only)	3230 {1465}	3830 {1737}	5030 {2282}	9750 {4423}	10800 {4899}	11850 {5375}
Mounting interfaces						
Hopper loader (Top)	IT07	IT07	IT07	IT07	IT07	IT07
Material discharge (Bottom)	IB09	IB09	IB09	IB09	IB09	IB09

SPECIFICATION NOTES:

Specifications can change without notice. Check with a Conair representative for the most current information.

Top for hopper loaders

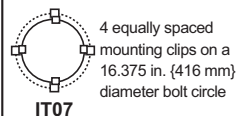

Bottom at discharge

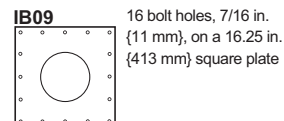

Specifications: CH Series Insulated Hoppers

With Integrated Cyclone

MODEL	CH54-70	CH54-85	CH54-99	CH54-114	CH54-129	CH64-158	CH64-187	CH64-215	CH64-248
FIGURE NUMBER	Fig. 2	Fig. 2	Fig. 2	Fig. 2	Fig. 2	Fig. 2	Fig. 2	Fig. 2	Fig. 2
Performance characteristics									
Capacity ft ³ {liter}	70 {1982}	85 {2407}	99 {2804}	114 {3228}	129 {3653}	158 {4475}	187 {5296}	215 {6089}	248 {7023}
Capacity @ 35 lb/ft ³	2450	2975	3465	3990	4515	5530	6545	7525	8680
Dimensions inches {cm}									
A - Inside diameter	54 {137}	54 {137}	54 {137}	54 {137}	54 {137}	64 {163}	64 {162}	64 {162}	64 {163}
B - Hopper height	101.3 {257}	120.1 {305}	132.1 {336}	138.1 {351}	150.1 {381}	144.6 {367}	158.6 {403}	174.6 {443}	192.6 {489}
C - Overall height	140.6 {357}	157.6 {400}	169.6 {431}	175.6 {446}	187.6 {477}	182.4 {463}	194.4 {494}	212.4 {539}	230.4 {585}
D - Width	96.4 {245}	96.4 {245}	96.4 {245}	96.4 {245}	96.4 {245}	101.8 {259}	101.8 {259}	101.8 {259}	101.8 {259}
E - Depth	96.4 {245}	96.4 {245}	96.4 {245}	96.4 {245}	96.4 {245}	101.8 {259}	101.8 {259}	101.8 {259}	101.8 {259}
Air inlet (OD)	8 {20.3}					8 {20.3}			
Air outlet (OD)	8 {20.3}					8 {20.3}			
Material discharge (ID)	6 {15.2}					6 {15.2}			
Approximate weight lb {kg}									
Installed weight (hopper and cyclone)	1650 {748}	1800 {816}	2000 {907}	2100 {953}	2200 {998}	2400 {1089}	2600 {1179}	2700 {1225}	2800 {1270}
Mounting interfaces									
Hopper loader (Top)	IT07	IT07	IT07	IT07	IT07	IT07	IT07	IT07	IT07
Material discharge (Bottom)	IB03	IB09	IB09	IB09	IB09	IB09	IB09	IB09	IB09

Description 2

With Integrated Cyclone

MODEL	CH74-245	CH74-366	CH74-487
FIGURE NUMBER	Fig. 2	Fig. 2	Fig. 2
Performance characteristics			
Capacity ft ³ {liter}	245 {6938}	366 {10365}	487 {13792}
Capacity @ 35 lb/ft ³	8575	12810	17045
Dimensions inches {cm}			
A - Inside diameter	74 {188}	74 {188}	74 {188}
B - Hopper height	170.2 {432}	218.2 {554}	266.2 {676}
C - Overall height	263.5 {669}	311.5 {791}	479.5 {1218}
D - Width	118.6 {301}	118.6 {301}	118.6 {301}
E - Depth	118.6 {301}	118.6 {301}	118.6 {301}
Air inlet (OD)	12 {30.5}		
Air outlet (OD)	12 {30.5}		
Material discharge (ID)	8 {20.3}		
Approximate weight lb {kg}			
Installed weight (hopper and cyclone)	3780 {1715}	4380 {1987}	5580 {2531}
Mounting interfaces			
Hopper loader (Top)	IT07	IT07	IT07
Material discharge (Bottom)	IB09	IB09	IB09

SPECIFICATION NOTES:
 Specifications can change without notice. Check with a Conair representative for the most current information.

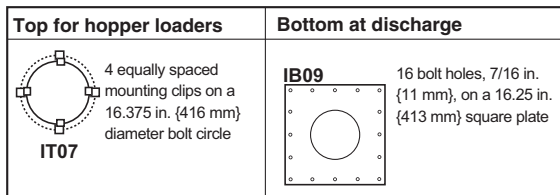

TPDS006-0408 REV

Specifications: Drying Monitor, DM-II Model

Angled Probe

Allows the DM-II to be used on hoppers that have insufficient clearance for correctly mounting the probe around loading devices.

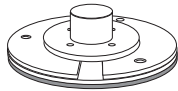

Probe Mounting Adapter Kit

(Includes half coupling, two mounting plates, screws and gasket)



NOTE: The mounting adapter kit will only be included if the DM-II was ordered as a retrofit kit. Otherwise, the adapter plate will already be in place on the hopper.

Drying Hopper #	Conair Part #
CH 54-70	1819080140
CH 54-85	1819080141
CH 54-99	1819080142
CH 54-114	1819080123
CH 54-129	1819080143
CH 64-158	1819080125
CH 64-187	1819080126
CH 64-215	1819080127
CH 64-248	1819080144
CH 74-245	1819080126
CH 74-366	1819080145
CH 100-450	1819080132
CH 100-675	1819080133
CH 100-900	1819080134

The DM-II package includes:

- Drying monitoring probe
- Connecting cable
- Pre-wired dryer panel
- Light tower

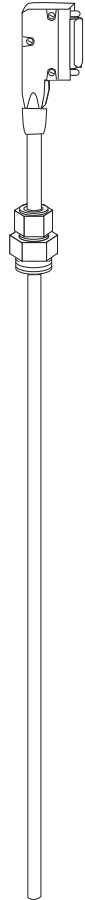

SPECIFICATION NOTES:

Specifications can change without notice. Check with a Conair representative for the most current information.

EnergySmart Dryer Control Options

- **Visual alarms** - The visual alarm is a blinking red alarm light that alerts the user to any shut down alarm.
- **Trending screens** - The trending screens display temperature, air flow, dew point and differential pressure of the EnergySmart Dryer System. Each can be used to graph real-time data of a running dryer system.
- **Recipe storage screen** - The recipe storage screen is used to store and instantly recall specific dryer parameters that are used with different types of material. Up to 99 dryer recipes can be saved within the control.
- **Loading control screens** - Dedicated screens control the function and activation of up to two (2) optional receivers. Loading, dump and purge times can be individually altered for each receiver.
- **Communications** - Allows the dryer to be networked to industrial control systems.

Installation

- Installation - General 3-5**
 - Unpacking the EnergySmart™ Dryer System
 - components 3-6
 - Preparing for installation 3-7
 - Positioning the CH hopper floor stand 3-8
 - Installation of the HTC control
 - (Models HTC 30, 60 and 90) 3-9
 - (Models HTC 120) 3-10
 - (Models HTC 180 and 270) 3-10
 - Location and mounting of the HTC heater assembly
 - (Models HTC 30, 60 and 90) 3-11
 - (Models HTC 120) 3-11
 - (Models HTC 180 and 270) 3-11
 - Installing the CH hopper cone section 3-12
 - Installing the CH hopper door, upper and lid sections . . 3-13
 - Installing the cyclone (optional) 3-17
 - Installing the drying monitor probe 3-22
 - Installing the receiver(s) (optional) 3-25
 - Installing the purge valve(s) (optional) 3-25
 - Installing the modular distribution box(s) (optional) 3-25
 - Securing the CH hopper to the floor 3-26
 - Location and mounting of the GasTrac heater 3-27
 - Location and mounting of the dust collector (optional) . . 3-28
 - Location and mounting of the vacuum pump(s)
 - and dust collector(s) (optional) 3-30
 - Positioning the dryer on the floor 3-31
 - Removing the cable tie from the desiccant
 - wheel (W600-1000 models) 3-31

Installation (continued)

Installing the regeneration exhaust cover 3-31

Installing the return air adapter 3-32

Installing the return air inlet and air outlet
adapters (W1600-5000 models) 3-33

Installing the overhead process air
duct (W3200-5000 models) 3-34

Installation - Piping/Hoses 3-35

Optional hard piping kits 3-36

Connecting the heat sources 3-37

Hopper temperature controller (HTC) as
heat source 3-37

GasTrac as heat source 3-38

Connecting the dryer to the heat source 3-39

Connecting the dust collector (optional) 3-40

Connecting the cyclone separator (optional) 3-41

Installing the Dwyer 641 air velocity
transmitter 3-42

Installing the level switch (optional) 3-44

Adjusting the level sensor (optional) 3-45

Installing the process protection RTD sensor 3-46

Location of the process material temperature
probe (RTD) 3-47

Installing the GasTrac RTD sensor 3-48

Installing the return air dew point line 3-49

Installation - Main Power Connections 3-51

Connecting main power to the dryer 3-52

Connecting main power to the HTC
(Models HTC 30, 60, 90 and 120) 3-53

Installation (continued)

(Models HTC 180 and 270)	3-54
Connecting main power to the GasTrac	3-56
Connecting main power to the vacuum pump(s) (optional)	3-57
Connecting main power to the dust collector(s) (optional)	3-57
Installation - Conveying Lines	3-59
Connecting the conveying lines to the receiver(s) (optional)	3-60
Connecting the conveying lines to the purge valves (optional)	3-60
Connecting the conveying lines to the vacuum pump(s) and dust collector(s) (optional) . . .	3-61
Installation - Water Lines	3-63
Typical water lines installation drawing.	3-64
Connecting the aftercooler/intercooler and optional precooler (W600-1000)	3-65
Connecting the aftercooler/intercooler and optional precooler (W1600-5000)	3-66
Installation - Control and Communications	
Wiring	3-67
Connecting the HTC to the HTC controller	3-68
Connecting the RTD sensors (HTC only)	3-70
Connecting the GasTrac RTD sensors.	3-72
Connecting the drying monitor probe to the dryer	3-73
Connecting the receiver to the level switch (optional)	3-74

Installation (continued)

Connecting the EnergySmart Dryer control to system components	3-75
Installation - Compressed Air Lines.	3-85
Connecting the compressed air lines (optional)	3-86
Installation - Gas Piping and Exhaust Flue.	3-87
Typical gas line installation drawing	3-88
Installing the Conair GasTrac	3-89
Connecting the gas and the exhaust flue to the GasTrac	3-92
Installation - Testing	3-95
Checking for proper air flow	3-96
Testing the variable frequency drive (VFD)	3-99
Testing the installation of the HTC	3-100
Checking the gas and electrical systems of the GasTrac	3-102
Testing the installation of the GasTrac	3-103
Testing the primary receiver (optional)	3-105
Testing the secondary receiver (optional)	3-107
Configuring the Dwyer 641 air velocity transmitter	3-109
Configuring the DM-II drying monitor	3-110
Configuring the level switch (optional)	3-110
Using communications (optional)	3-113

Installation - General

Unpacking the EnergySmart™ Dryer System Components

Because of their size and shape and the multiple sizes in which the hopper is available, the components of the EnergySmart Dryer System come packaged for shipping in the best available manner. The EnergySmart System components include, depending on the model and options ordered:

- EnergySmart Dryer with TouchView Technology - Allen-Bradley control
- CH Hopper - with or without integrated cyclone - optional
- Heater (HTC or GasTrac)
- Dust Collector(s) - optional
- DM-II Drying Monitor
- Receiver(s) - up to two (2) - optional
- Vacuum pump - up to two (2) - optional
- Hard piping kit - optional



NOTE: Some components may be strapped to their shipping pallet, remove as necessary.

- 1 For the EnergySmart Dryer System components that are mounted to pallets,** remove the hardware securing each component to its pallet, then remove the component from the pallet. With a forklift, hoist or crane carefully move the components to their approximate installation locations.
- 2 Remove all packing material,** protective paper, tape and plastic, including any inserted inside the components.
- 3 Carefully inspect all components** to ensure no damage occurred during shipping, and that you have all the necessary hardware. If any damage is found, notify the shipping agent immediately.
- 4 Take a moment to record serial numbers** and electrical power specifications in the blanks provided on the back of the User Guide's title page. This information will be helpful if you ever need service or parts.
- 5 You are now ready to begin installation.** Follow the preparation steps in the next section.
- 6 Determine if your application is electric or gas. Disregard installation steps for options not used.**

Preparing for Installation

The EnergySmart Dryer System is easy to install if you plan the location and prepare the installation area properly.

1 Make sure the installation area provides:

- ❑ **Grounded power sources supplying the correct voltages and currents for your system components.** Check each component's serial tag for the correct amps, voltage, phase and cycles. Field wiring to each component should be completed by qualified electrical personnel. All electrical wiring should comply with your region's electrical codes.
- ❑ **Minimum clearance above and around each component for safe operation and maintenance.** Refer to the component manuals supplied with your EnergySmart Dryer System to determine minimum clearances needed for each component.
- ❑ **A mounting area that will support the weight of the fully loaded CH Hopper, floor stand and the other system components.** Refer to the specifications supplied with your EnergySmart Dryer System for the weights of each component.
- ❑ **A source of water for the aftercooler/intercooler or optional pre-cooler of the dryer.** The water source must be tower, city or chiller water at temperatures of 45° to 85°F {7° to 29°C}. Refer to the specifications supplied with your system for the flow rate. Piping should be installed to the dryer location. Flexible hose can be used to connect the water pipes to the aftercooler/intercooler or optional pre-cooler.
- ❑ **If the heat source supplied with your EnergySmart Dryer System is a GasTrac (CGT), the installation location must provide for an exhaust flue and gas lines that meet all applicable local, regional and national codes.** Conair recommends that the GasTrac should have a dedicated vertical stack that exits the building through a rain-protected roof penetration. *See Installation section entitled, Connecting the Gas and the Exhaust Flue to the GasTrac.*
- ❑ **Material and conveying lines installed.** If you plan to use optional vacuum receivers to fill the CH Hopper, install conveying lines to the hopper location as well as to the optional vacuum pump(s) and its associated dust collector(s) used within your EnergySmart Dryer System.

Positioning the CH Hopper Floor Stand

 **WARNING:** You are responsible for the structural integrity of this installation.

 **CAUTION:** Care should be taken while moving the main CH Hopper floor stand and sections to ensure that no damage occurs during assembly.

 **IMPORTANT:** You will need to consider the installation of your entire dryer system before permanently placing any system component, *see [Installation - Piping and Hoses for reference](#)*.

 **NOTE:** For EnergySmart Dryer Systems supplied with "small" hoppers, the floor stand and cone section may be pre-assembled from Conair.

Due to the varying size of Conair CH Hoppers, Conair recommends:

- Following all applicable local building and safety codes
- 1 Make sure the installation location for the CH Hopper meets all provisions for clearances, will support the weight of the fully loaded hopper and provides space for the installation of the other system components, such as optional receivers.** See the specifications and drawings supplied with your system for details.
 - 2 Using a forklift, hoist or crane, move the floor stand to its installation location.**

Installation of the HTC Control (Models HTC 30, 60, and 90)

 **CAUTION:** You are responsible for the structural integrity of this installation.

 **NOTE:** The HTC control is shipped mounted on the left side of the CH Hopper floor stand on models 30, 60 and 90.

 **NOTE:** If, by using your own provisions, you change the mounting arrangement of the control center to a wall mount unit, it must be mounted 6 inches {152.4 mm} off of the wall to provide clearance for the heat sink.

 **NOTE:** If using a GasTrac for the drying system heat source, [see Installation section entitled, Installing the CH Hopper Cone Section.](#)

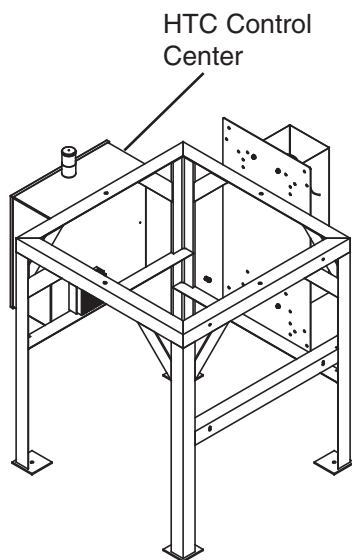

Installation of the HTC Control

(continued) (Model HTC 120)

 **CAUTION:** You are responsible for the structural integrity of this installation.

HTC Control Center

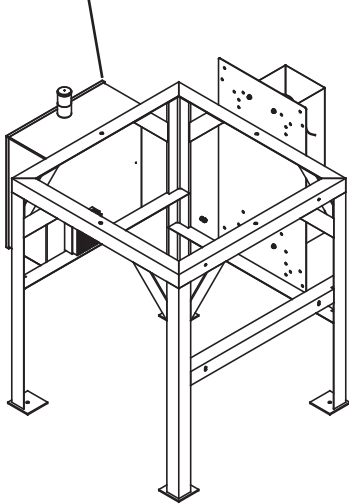

1 Securely bolt the HTC control to the left side of the floor stand. Use the supplied locking fasteners to securely mount the HTC control center to the floor stand to prevent vibration-induced loosening.

 **NOTE:** If, by using your own provisions, you change the mounting arrangement of the control center to a wall mount unit, it must be mounted 6 inches {152.4 mm} off of the wall to provide clearance for the heat sink.

Installation of the HTC Control

(continued) (Models HTC 180 and 270)

 **NOTE:** If the lengths of the process and process protection RTD wiring are too short for your installation, contact Conair Parts Department (800.458.1960) to purchase extension cables. From outside the United States, call 814.437.6861.

 **CAUTION:** You are responsible for the structural integrity of this installation.

1 Move the control center into its final location for operation (see figure to the right). The control center must be positioned close enough to the hopper to allow connection of the RTD temperature probe.

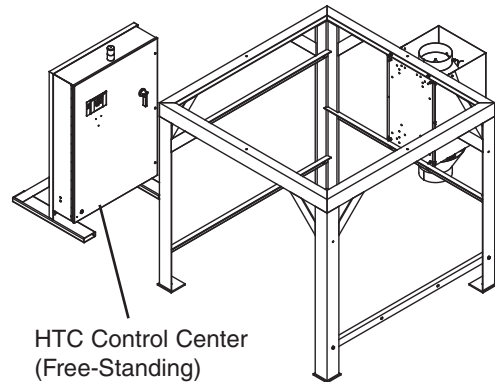

The control center can be mounted to a wall, the hopper frame or a floor stand with customer supplied provisions.

 **NOTE:** If using a GasTrac for the drying system heat source, [see Installation section entitled, Installing the CH Hopper Cone Section.](#)

 **NOTE:** If, by using your own provisions, you change the mounting arrangement of the control center to a wall mount unit, it must be mounted 6 inches {152.4 mm} off of the wall to provide clearance for the heat sink.

Location and Mounting of the HTC Heater Assembly (Models HTC 30, 60 and 90)

 **CAUTION:** You are responsible for the structural integrity of this installation.

 **NOTE:** The HTC heater assembly is shipped mounted to the back of the floor stand on Models 30, 60 and 90 (see figure to the right).

 **NOTE:** The heater is prewired to the control box on HTC Model 30, 60 and 90.

Location and Mounting of the HTC Heater Assembly (Model HTC 120)

 **CAUTION:** You are responsible for the structural integrity of this installation.

1 Securely bolt the HTC heater assembly to the back of the floor stand (see figure to the right). Use the locking fasteners provided to securely mount the heater assembly to the floor stand to prevent vibration-induced loosening.

 **NOTE:** The heater is prewired to the control box on HTC Model 120.

Location and Mounting of the HTC Heater Assembly (Models HTC 180 and 270)

 **CAUTION:** You are responsible for the structural integrity of this installation.

1 Securely bolt the HTC heater assembly to the back of the floor stand (see figure to the right). Use the locking fasteners provided to securely mount the heater assembly to the floor stand to prevent vibration-induced loosening.

2 Refer to the wiring diagram to make the wiring connections for the heater and control box. Only a qualified electrician should make the wiring connections between the control and the heater. The customer must supply the appropriately-sized wire and conduit to make connections.

 **IMPORTANT:** Always refer to the wiring diagrams that came with your HTC before making electrical connections.

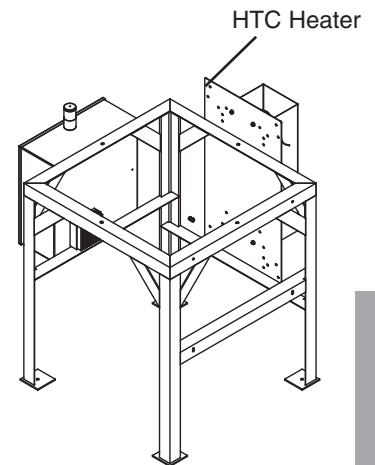

 **CAUTION:** Always disconnect and lock out the main power sources before making electrical connections. Electrical connections should be made only by qualified personnel.

 **CAUTION:** Check the disconnect with a volt meter to ensure that the power is off.

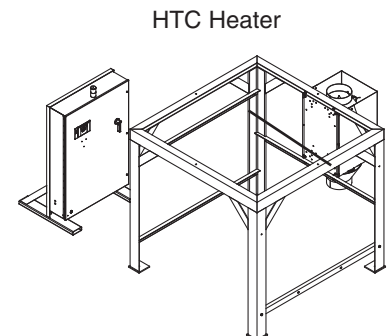

 **NOTE:** For EnergySmart Dryer Systems supplied with "small" hoppers, the floor stand and cone section may be pre-assembled at the factory. If your floor stand and cone section are pre-assembled and you have secured the floor stand to the floor, *see Installation section entitled, Installing the CH Hopper Door, Upper and Lid Sections.*

 **NOTE:** If using carbon steel hoppers, be sure to clean out the hopper prior to use. Conair applies a rust inhibitor that must be removed several hours before using the hopper.

Installing the CH Hopper Cone Section

Install the hopper cone section on the floor stand using the following steps.

 **IMPORTANT:** You will need to consider the location of the CH Hopper's delivery air inlet in relation to the dryer installation location for proper setup.

 **IMPORTANT:** You will need to consider the location of the HTC heater outlet in relation to the CH Hopper air inlet location for proper setup.

1 If any hoses, wires, etc. were attached to the floor stand and cone section (for shipping purposes), make sure they are positioned away from the mating surfaces of the assemblies so they will not be damaged during this procedure.

2 Using a forklift, hoist or crane, lift the cone section assembly above the floor stand.

 **CAUTION:** To prevent accident and injury, lift the cone and hopper sections onto the floor stand assembly using a forklift, hoist or crane.

3 Set the cone section on the floor stand as shown. Make sure the holes in the cone section mounting lugs align with the holes in the top of the floor stand assembly.

4 Secure the cone section to the floor stand assembly using the supplied hardware.

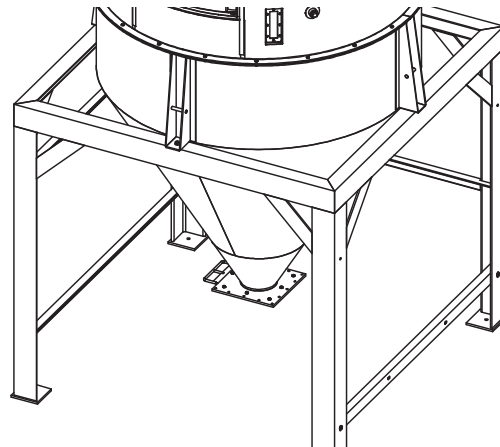

Installing the CH Hopper Door, Upper and Lid Sections

⚠ IMPORTANT: Before installing the hopper door, upper (if applicable), and lid sections of the CH Hopper, careful consideration should be given to the following:

- When installing the hopper door section, make sure the hopper door is positioned to allow easy access into the hopper to aid in installation and to facilitate hopper cleaning and maintenance in the future.
- When installing the hopper lid section, make sure to identify the location of the hopper’s return air outlet. The lid section has multiple piping options that can be connected to an optional cyclone or traditional CH Hopper outlet, then to an optional dust collector and finally to the dryer’s return air inlet. Consider all piping/hosing possibilities when installing the dryer, heater (gas or electric), optional dust collector and optional cyclone before making the installation permanent.

Hopper Door Section

To install the hopper door section of the CH Hopper:

- 1 Apply sealer around the lip on the top of the cone section.**
- 2 Using a forklift, hoist or crane, lift the hopper door section assembly above the cone section.**

⚠ CAUTION: To prevent accident and injury, lift the hopper door section onto the cone section using a forklift, hoist or crane.

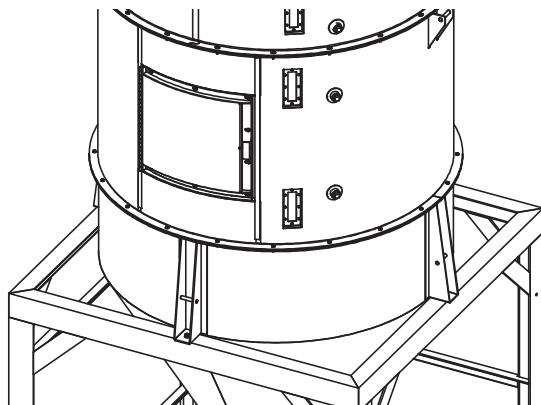

🔧 TIP: Conair recommends applying strip and stick sealer 1/8 inches {3.2 mm} from the inside to the edge of the CH Hopper.

📎 NOTE: When applying the sealer, do not cover the holes in the cone section lip. Apply the sealer around the holes so you will have a good seal but not interfere with the mounting hardware that will be used to secure the hopper door section to the cone section.

📎 NOTE: When installing the hopper door section, make sure the hopper door is positioned to allow easy access into the hopper to aid in the continuing installation and to facilitate hopper cleaning and maintenance in the future.

(continued)

Installing the CH Hopper Door, Upper and Lid Sections (continued)

Hopper Door Section (continued)

- 3** Set the hopper door section on the cone section as shown. As the hopper door section is positioned on the cone section, make sure the holes in the hopper door section align with the holes in the cone section.

- 4** Secure the hopper door section to the cone section using the supplied hardware.

Installing the CH Hopper Door, Upper and Lid Sections (continued)

Hopper Upper Section(s) (If Applicable)

To install the hopper upper section(s) of the CH Hopper:

1 Apply sealer around the lip on the top of the hopper door section.

2 Using a forklift, hoist or crane, lift the hopper upper section assembly above the hopper door section.

⚠ CAUTION: To prevent accident and injury, lift the hopper upper section onto the hopper door section using a forklift, hoist or crane.

⚠ IMPORTANT: Line up the sight glasses of the hopper upper section(s) with the sight glasses of the hopper door section.

3 Set the hopper upper section on the hopper door section. As the hopper upper section is positioned on the hopper door section, make sure the holes in the upper section align with the holes in the door section.

✎ NOTE: If more than one (1) hopper upper section is to be installed, repeat the steps detailed in this section for each hopper upper section.

4 Secure the hopper upper section to the hopper door section using the supplied hardware.

✎ TIP: Conair recommends applying strip and stick sealer 1/8 inches {3.2 mm} from the inside to the edge of the CH Hopper.

✎ NOTE: When applying the sealer, do not cover the holes in the hopper door section lip. Apply the sealer around the holes so you will have a good seal but not interfere with the mounting hardware that will be used to secure the hopper upper section to the hopper door section.

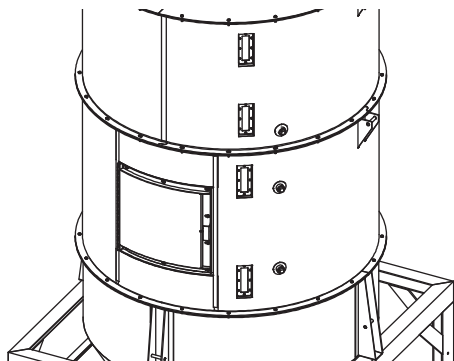

(continued)

Installation - General | 3-15

Installing the CH Hopper Door, Upper and Lid Sections (continued)

Hopper Lid Section

✦ **TIP:** Conair recommends applying strip and stick sealer 1/8 inches {3.2 mm} from the inside to the edge of the CH Hopper.

✎ **NOTE:** When applying the sealer, do not cover the holes in the upper section lip. Apply the sealer around the holes so you will have a good seal but not interfere with the mounting hardware that will be used to secure the hopper lid section to the hopper upper section.

⚠ **WARNING:** To accomplish the following steps, it may be necessary for personnel to enter the CH Hopper assembly. If it is necessary to enter the hopper assembly, all applicable OSHA procedures for working within a confined space **MUST BE** followed.

⚠ **IMPORTANT:** Improper mounting of the hopper lid will cause interference when installing the DM-II monitor probe and optional integrated cyclone. See the illustration below for recommended hopper lid mounting locations.

To install the hopper lid section of the CH Hopper:

1 Apply sealer around the lip on the top of the hopper door or hopper upper section, if applicable.

2 Using a forklift, hoist or crane, lift the hopper lid section assembly above the hopper door or hopper upper section.

⚠ **CAUTION:** To prevent accident and injury, lift the hopper lid section onto the hopper door or hopper upper sections using a forklift, hoist or crane.

3 Set the hopper lid section on the hopper door or hopper upper section as shown below. As the hopper lid section is positioned on the hopper door or hopper upper section, make sure the holes in the hopper lid section align with the holes in the hopper door or hopper upper section.

4 Secure the hopper lid section to the hopper door or hopper upper section using the supplied hardware.

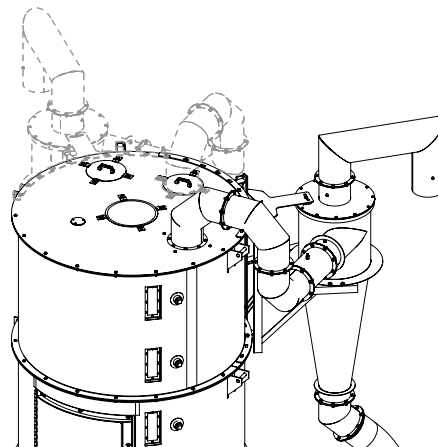

Installing the Cyclone (optional)

The optional cyclone separator is designed to be mounted to the return air outlet of the CH Hopper.

⚠ IMPORTANT: The optional cyclone is designed to be connected to the return air circuit of the CH Hopper, then connected to an optional dust collector or to the dryer's air inlet.

To install the cyclone to the CH Hopper:

1 Using a forklift, hoist or crane, raise the cyclone's mounting bracket to its installation location on the side of the CH Hopper. Installation location depends upon your system setup.

⚠ CAUTION: To prevent accident and injury, move the cyclone separator to its mounting location using a forklift, hoist or crane.

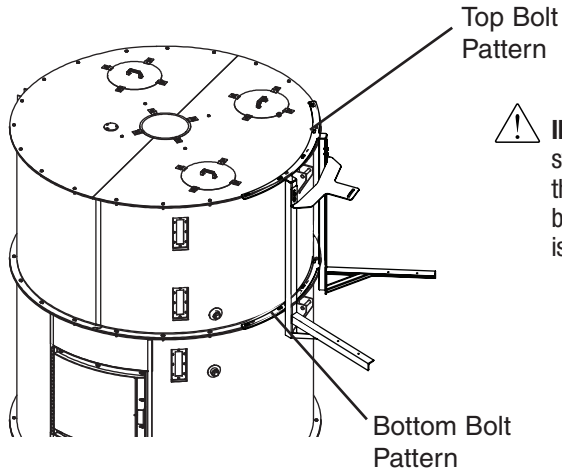

⚠ IMPORTANT: Reference your system layout drawings for the correct cyclone bracket bolt pattern usage **before** it is installed.

2 Remove the five (5) bolts located on the top of the lid of the hopper. The removal of the five (5) bolts is dependent upon the installation location of the cyclone.

3 Remove the five (5) bolts located on the hopper upper section or hopper door section of the hopper. The removal of the five (5) bolts is dependent upon the installation location of the cyclone.

Installing the Cyclone (optional) (continued)

4 Bolt the cyclone bracket to the CH Hopper, using the hardware removed in Steps 2 and 3. Do not fully tighten the bolts, the cyclone installation may need to be adjusted for hard piping of the cyclone's inlet and outlet ports.

5 Using a forklift, hoist or crane, raise the cyclone body to its installation location on the bracket mounted to the CH Hopper. Installation location depends upon your system setup.



CAUTION: To prevent accident and injury, move the cyclone separator to its mounting location using a forklift, hoist or crane.

6 Mount the cyclone body to its installation location on the bracket using the supplied hardware. Do not tighten the bolts, the cyclone installation may need to be adjusted for hard piping of the cyclone's inlet and outlet ports.

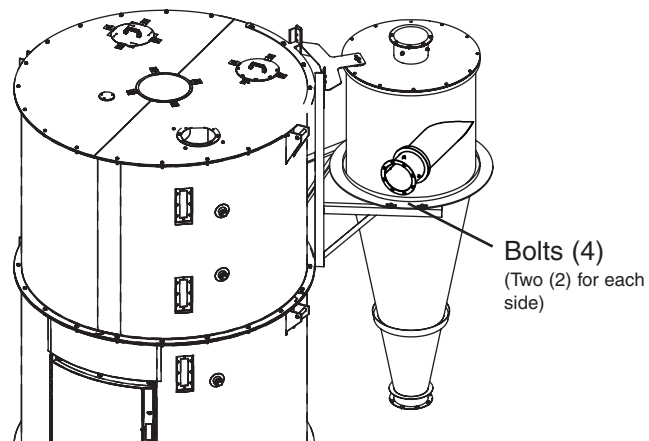

7 Locate the three (3) 90 degree pieces of tubing. These pieces will connect the CH Hopper to the cyclone.

8 Bolt two (2) of the pieces of 90 degree tubing together using the supplied hardware. Be sure to place the supplied gasket between the two (2) pieces of tubing before tightening the tube bolts. One of the pieces includes the dew point return port; the port should be located on the same end as the connection of the two (2) pieces of 90 degree tubing.

Installing the Cyclone (optional) (continued)

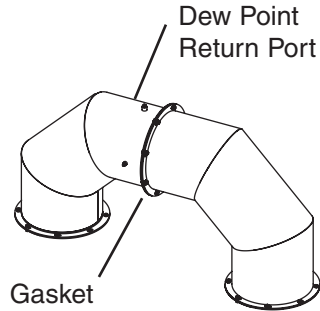

- 9 Bolt the third piece of 90 degree tubing to the assembly in Step 8 using the supplied hardware.** The third piece of 90 degree tubing should be bolted to the end of the assembly in Step 8 that DOES NOT have the dew point return port. Be sure to place the supplied gasket between the two (2) pieces of tubing before tighten the tube bolts.

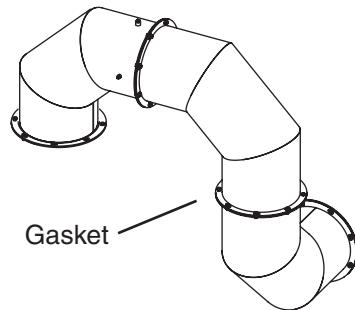

- 10 Loosely bolt the now finished tubing assembly to the CH Hopper's return air outlet and to the cyclone's air inlet, using the supplied hardware.** Be sure to place the supplied gaskets between the tubing assembly and the CH Hopper outlet and cyclone air inlet before tightening bolts. Mounting location is dependent upon the installation location of the cyclone.

Installing the Cyclone (optional) (continued)

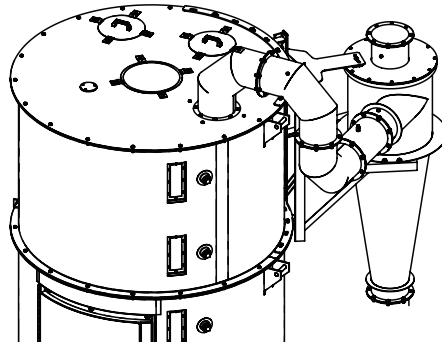

- 11** Be sure to make any adjustments necessary to the cyclone or tubing assembly.
- 12** Tighten all bolts within the cyclone and tubing assemblies with an appropriately-sized wrench.
- 13** Locate the 45 degree piece of tubing.
- 14** Bolt the 45 degree piece of tubing to the outlet of the cyclone using the supplied hardware. Be sure to place the supplied gasket between the tubing and the cyclone outlet before tightening bolts. Mounting orientation is dependent upon your system's configuration.
- 15** Bolt the straight piece of tubing to the assembly in Step 14 using the supplied hardware. Be sure to place the supplied gasket between the two (2) pieces of tubing before tighten the tube bolts.

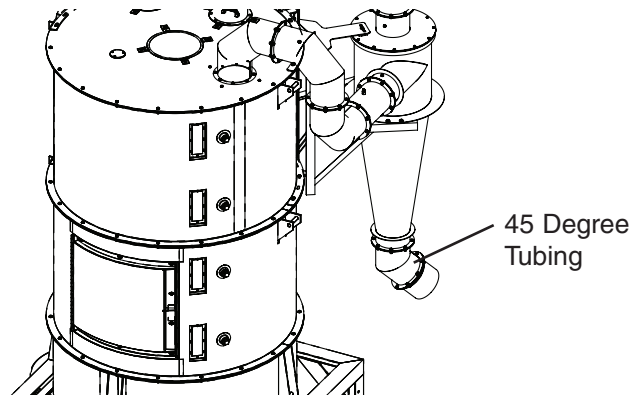

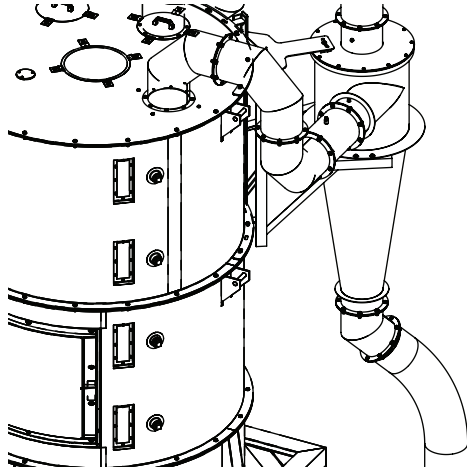

Installing the Cyclone (optional) (continued)

- 16** Locate the supplied hosing used for the cyclone's waste container.
- 17** Connect the hosing to the straight piece of tubing installed in Step 15 using the supplied hose clamp.

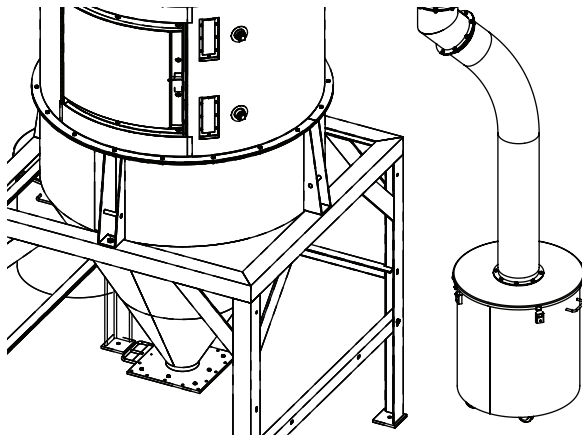

- 18** Route the hose to the waste container. Make sure all hoses are securely clamped to prevent wasteful leaking. The hoses should be routed neatly and supported where possible to prevent undue stress on cyclone assembly.



 **NOTE:** Do not allow the flexible hoses to kink or crimp.

- 19** Connect the hosing to the waste container's lid using the supplied hose clamp.

Installing the Drying Monitor Probe

From the Top of the CH Hopper

The Drying Monitor (DM) probe can be inserted through the existing hole in the top of the CH Hopper lid section and secured to a threaded coupling with an appropriate fitting.

- 1 Insert the DM probe through the coupling in the top of the hopper lid section.**
- 2 Screw the fitting into the coupling.**
Tighten the fitting with an appropriately-sized wrench.
- 3 Position the probe so it extends from just above the top of the hopper lid section into the hopper, with the tip of the probe approximately in-line with the bottom edge of the dry air spreader cone.**

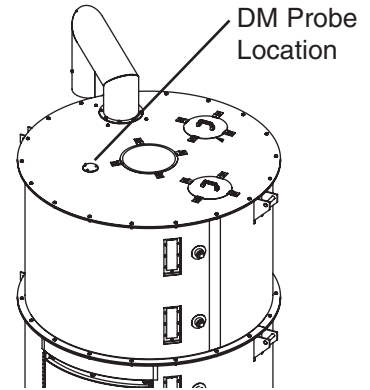

- 4 Push the compression sleeve into the fitting.**
- 5 Tighten the nut over the sleeve.** The compression sleeve will crimp the tube to hold the probe in place. Be sure to position the connector on the DM probe in such a way as to avoid interference with cables, receiver, etc. Use an appropriately-sized wrench to tighten the nut so that it covers all the threads of the fitting.

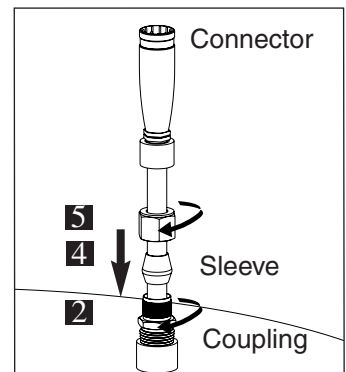

 **NOTE:** The DM probe's cable will be connected to the probe and the dryer later in the installation process.

Installing the Drying Monitor Probe

(continued)

Through the Door of the CH Hopper

The Drying Monitor (DM) probe can also be installed from the inside of the CH Hopper and secured to the hopper lid section.

- 1 Remove the two (2) adapter plates from the probe mounting assembly.** Set the adapter plates aside for use in Step 5.
- 2 Insert the probe and mounting assembly through the door of the CH Hopper.**
- 3 Pull the probe and mounting assembly through the hole in the top of the hopper.** Fold the gasket around the probe so that it will fit through the hole.

- 4 Place the gasket over the probe hole.**

- 5 Place the adapter plates over the gasket and secure them to the hopper with three (3) 10-32 UNF screws.**
Make sure the adapter plate with the threaded hole is on the bottom, and that the slots in the adapter plates are oriented in the opposite direction as shown (See the drawing on the next page).

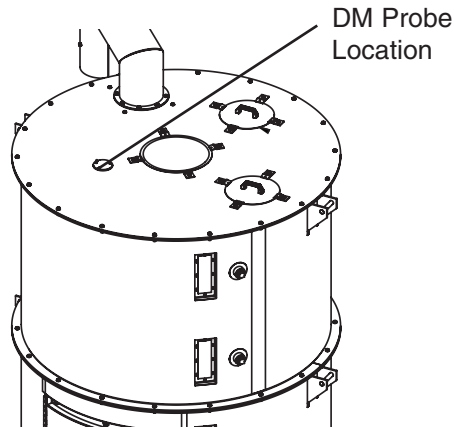

- 6 Secure the coupling to the adapter plates with the four (4) 10-32 UNF screws.**
- 7 Screw the fitting into the coupling.** Tighten with an appropriately-sized wrench.
- 8 Make sure the probe is the correct size. The probe should extend from just above the top of the hopper into the hopper, with the tip approximately in-line with the bottom edge of the diffuser cone.**

(continued)

Installing the Drying Monitor Probe

(continued)

Through the Door of the CH Hopper (continued)

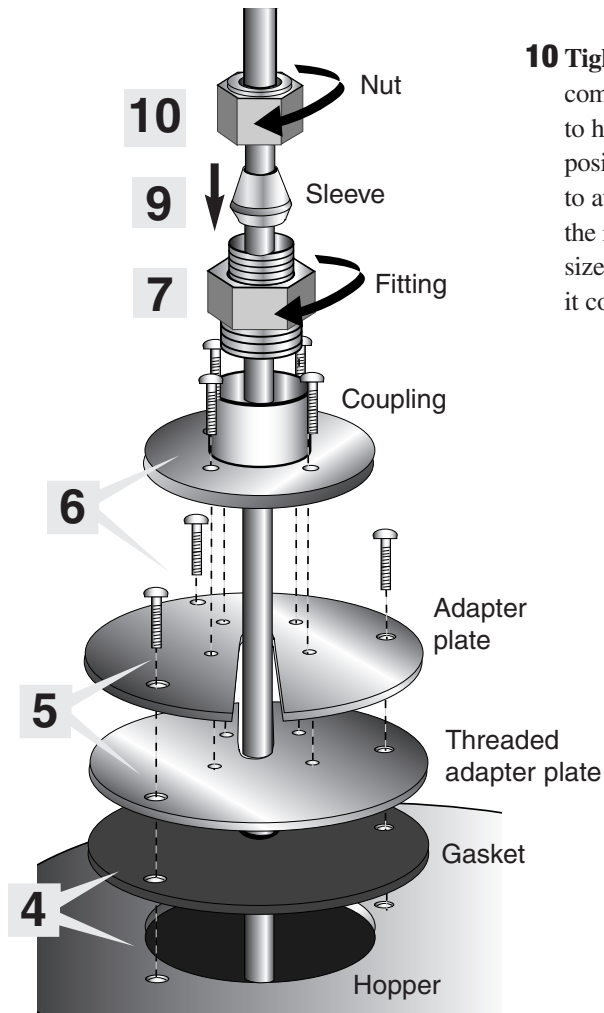

9 Push the compression sleeve into the fitting.

10 Tighten the nut over the sleeve. The compression sleeve will crimp the tube to hold the probe in place. Be sure to position the connector in such a way as to avoid interference of the cable with the receiver, etc. Use an appropriately-sized wrench to tighten the nut so that it covers the threads.

Installing the Receiver(s) (optional)

If a receiver is to be mounted to the top of the CH Hopper, auxiliary hopper or machine throat, follow the installation instructions, specifications and wiring diagrams supplied with the receiver. Also refer to the receiver's installation instructions and operations manual for power, level switch and compressed air connections/specifications.

Installing the Purge Valve(s) (optional)

If a purge valve is to be mounted to the bottom of the CH Hopper or auxiliary hopper follow the installation instructions, specifications, and wiring diagrams supplied with the valve. Also refer to the purge valve's installation instructions and operations manual for power, compressed air connections/specifications.

Installing the Modular Distribution Box(es) (optional)

If a modular distribution box is to be mounted to the bottom of the CH Hopper or auxiliary hopper follow the installation instructions, specifications, and wiring diagrams supplied with the box. Also refer to the modular distribution box's installation instructions and operations manual compressed air connections/specifications.

Securing the CH Hopper to the Floor

 **WARNING:** You are responsible for the structural integrity of this installation.

 **IMPORTANT:** Fasten the CH Hopper floor stand to a rigid floor structure. This will add rigidity to the installation and help to prevent accidents during operation and maintenance of the CH Hopper.

Due to the varying size of Conair CH Hoppers, Conair recommends:

- Following all applicable local building and safety codes
- Using anchoring techniques and hardware suitable for the size and weight of a fully loaded CH Hopper. *See Description section entitled, Specifications: CH Series Insulated Hoppers.*

1 Secure the floor stand to the floor; following all applicable building and safety codes.

 **NOTE:** The footpads on the floor stand have existing holes that can be used for anchoring the floor stand depending on the local building and safety codes.



Location and Mounting of the GasTrac Heater (if equipped)

The GasTrac supplied with the EnergySmart Dryer System is designed to be mounted to the floor near the CH Hopper air inlet.

- 1 Using a forklift, hoist or crane, move the GasTrac to its installation location near the air inlet of the CH Hopper.**

 **CAUTION:** To prevent accident and injury, move the GasTrac to its location by using a forklift, hoist or crane.

- 2 Position the GasTrac so that the gas, main power supply and exhaust flue can be connected easily.**

 **IMPORTANT:** You will need to consider the location of the CH Hopper's delivery air inlet and the dryer installation location to properly install the GasTrac.

- 3 Secure the GasTrac to the mounting location floor using the holes in the base of the GasTrac.** Check to ensure that the mounting method meets all local, regional and national codes and regulations.

 **NOTE:** Electrical, control, air flow, gas and exhaust flue connections to the GasTrac will be covered later in the installation process.

 **NOTE:** If your system has electrical heaters, for the drying system heat source, [see Installation section entitled, Location and Mounting of the HTC.](#)

Location and Mounting of the Dust Collector (optional)

The optional dust collector that is used with your EnergySmart Dryer System is designed to be mounted to the floor near the CH Hopper and optional integrated cyclone.

To install the optional dust collector:

- 1 Using a forklift, hoist or crane, move the dust collector to its installation location** near the CH Hopper and optional integrated cyclone.

! **IMPORTANT:** You will need to consider the installation of your entire dryer system before permanently placing any system component.

! **CAUTION:** To prevent accident and injury, move the dust collector to its mounting location using a forklift, hoist or crane.

- 2 Secure the dust collector to the mounting location on the floor by using the holes in the legs of the dust collector.** Ensure that the mounting method meets all local, regional and national codes and regulations.

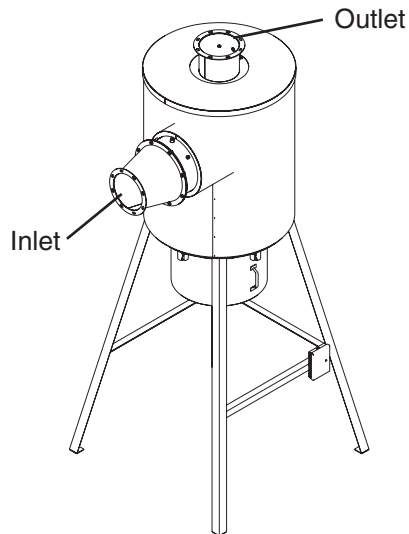

Location and Mounting of the Dust Collector (optional) (continued)

3 Ensure that the hoses from the differential pressure transmitter, mounted to the dust collector leg, have not become detached from the dust collector's inlet and outlet tubes during installation.

 **NOTE:** Electrical, control and air flow connections to the dust collector will be covered later in the installation process.

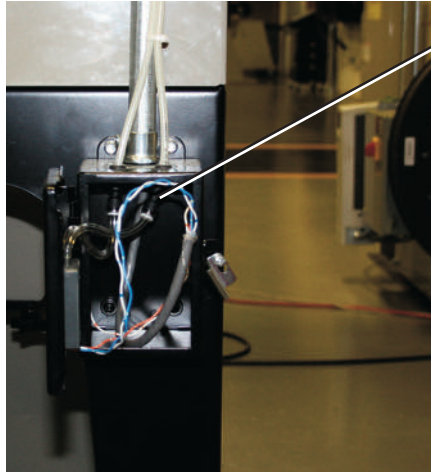

Pressure
Differential
Transmitter

NOTE: Dust collector shown with straight legs. Your EnergySmart Dryer system will be supplied with dust collectors with "kick-out" legs.

Location and Mounting of the Vacuum Pump(s) and Dust Collector(s) (optional)

The optional vacuum pump(s) and associated dust collector(s) supplied with the EnergySmart Dryer System are designed to be mounted to the floor and in any convenient location near the CH Hopper.

- 1 Using a forklift, hoist or crane, move the vacuum pump(s) and associated dust collector(s) to their installation location.**

 **CAUTION:** To prevent accident and injury, move the vacuum pump(s) and associated dust collector(s) to their locations by using a forklift, hoist or crane.

- 2 Position the equipment so that the main power supply, communication cables and conveying lines can be connected easily.**

 **IMPORTANT:** You will need to consider the location of all EnergySmart Dryer System components to properly install the vacuum pump(s) and associated dust collector(s).

- 3 Secure the vacuum pump(s) and associated dust collector(s) to their mounting locations on the floor by using the holes in the base of each component.** Ensure that the mounting method meets all local, regional and national codes and regulations.

Positioning the Dryer on the Floor

To position the dryer:

- 1 Lift the dryer from the shipping container** using a fork truck.
- 2 Position the dryer on the floor near the CH Hopper.** Make sure the location allows easy connection to the heat source (HTC or GasTrac), water connections and to the outlet of the optional dust collector.

Removing the Cable Tie from the Desiccant Wheel (w600-1000 models)

The EnergySmart Dryer's desiccant wheel cable tie must be removed while installing the dryer.

To remove the cable tie:

- 1 Open the dryer side panels and remove the cable tie securing the desiccant wheel,** if it was not done while unpacking the dryer.

Installing the Regeneration Exhaust Cover

The EnergySmart Dryer's regeneration exhaust cover must be installed before using the dryer.

To install the regeneration exhaust cover:

- 1 Remove the exhaust cover that is attached to the dryer's shipping pallet.**
- 2 Locate the bolt pattern on the top of the dryer,** over top of the regeneration exhaust outlet.
- 3 Position the regeneration exhaust cover over top of the regeneration exhaust outlet,** aligning both bolt patterns.
- 4 Secure the regeneration exhaust cover with supplied hardware,** using an appropriately-sized wrench.

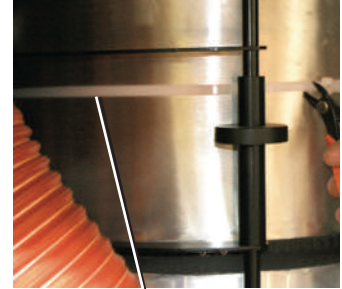

Desiccant Cable Tie

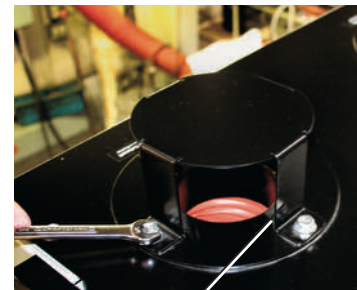

Regeneration Exhaust Cover

Installing the Return Air Adapter

The EnergySmart Dryer's return air adapter must be installed before using the dryer.

 **NOTE:** If your system has hard piping, use the instructions in the next section.

To install the return air adapter:

- 1 Remove the return air adapter that is attached to the dryer's shipping pallet.**
- 2 Locate the bolt pattern on the top of the dryer, over top of the return air inlet.**
- 3 Position the return air adapter over top of the return air inlet, aligning both bolt patterns.**
- 4 Secure the return air adapter with supplied hardware, using an appropriately-sized wrench.**

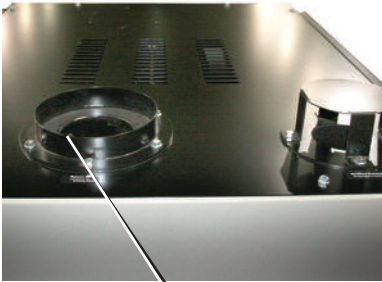

Return Air
Inlet Adapter

An optional hard piping kit for your EnergySmart Dryer system is available from Conair.

Contact Conair Parts
(800) 458 1960
From outside of the
United States, call:
(814) 437 6861

Installing the Return Air Inlet and Air Outlet Adapters (W1600 - 5000)

The EnergySmart Dryer's return air inlet and air outlet adapters will be removed when the dryer is shipped.

To install the return air inlet and air outlet adapters:

- 1 Remove the return air inlet and dry air outlet adapters that are attached to the dryer's shipping pallet.**
- 2 Locate the bolt patterns on the top of the dryer, over top of the return air inlet and dry air outlet.**
- 3 Position the return air adapter over top of the return air inlet, aligning both bolt patterns.**
- 4 Secure the return air adapter with supplied hardware, using an appropriately-sized wrench.**
- 5 Position the dry air outlet adapter over top of the dry air outlet, aligning both bolt patterns.**
- 6 Secure the dry air outlet adapter with supplied hardware, using an appropriately-sized wrench.**



 **NOTE: An optional hard piping kit for your EnergySmart Dryer system is available from Conair.**

Contact Conair Parts
 (800) 458 1960
 From outside of the
 United States, call:
 (814) 437 6861

Installing the Overhead Process Air Duct (w3200 - 5000)

The EnergySmart Dryer's overhead process air duct will be removed when the dryer is shipped.

To install the overhead process air duct:

- 1 Remove the overhead process air duct that is attached to the dryer's shipping pallet.** The piping will be shipped as one unit with included gaskets (2).
- 2 Locate the bolt patterns on the top of the dryer,** over top of the overhead process air duct inlet and outlet.
- 3 Position the overhead process air duct over top of the overhead process air duct inlet and outlet making sure to place supplied gaskets between the overhead process air duct and the inlet and outlet of the dryer,** align all bolt patterns.
- 4 Secure the piping with supplied hardware,** using an appropriately-sized wrench.

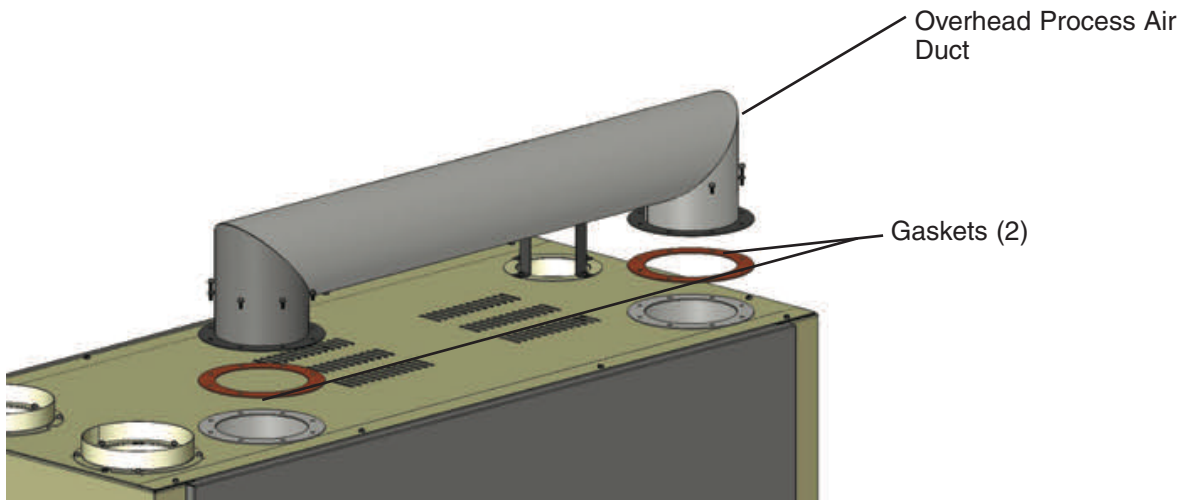

Installation - Hard Piping Kits

Optional Hard Piping Kits

The following sections detail the pipe/hose connections between the components of the EnergySmart Dryer System. The piping can consist of hard piping or flexible tubes.

Conair offers both 8 inch and 12 inch {203.2 and 304.8 mm} hard piping kits that can be used for your EnergySmart Dryer System installation. For more information concerning hard piping kits, contact your Conair Representative.

An optional hard piping kit for your EnergySmart Dryer system is available from Conair.

Contact Conair Parts
(800) 458 1960
From outside of the
United States, call:
(814) 437 6861

Connecting the Heat Sources

Hopper Temperature Controller (HTC) as Heat Source

 **NOTE:** If your EnergySmart Dryer System was supplied with a GasTrac as the heat source, see *Installation section entitled, Connecting the Heat Sources, Gastrac Heat Source.*

- 1** Using insulated hard piping or flexible hose, connect the HTC outlet to the air inlet of the CH Hopper. If flexible hose is used, make sure it is securely clamped.



HTC Outlet to CH Hopper Inlet Connection

Make sure all hoses are securely clamped to prevent wasteful leaking. The hoses should be routed neatly and supported where possible to prevent undue stress on the heater and hopper assemblies. Also, the bends should be made with gradual radiuses. Sharp turns will cause undue pressure drops.

 **NOTE:** Do not allow the flexible hoses to kink or crimp.

An optional hard piping kit for your EnergySmart Dryer system is available from Conair.

Contact Conair Parts
(800) 458 1960
From outside of the United States, call:
(814) 437 6861

Connecting the Heat Sources (continued)

GasTrac as Heat Source

- 1** Using insulated hard piping or flexible hose, connect the GasTrac outlet to the air inlet of the CH Hopper. If an insulated flexible hose is used, make sure it is securely clamped.

An optional hard piping kit for your EnergySmart Dryer system is available from Conair.

Contact Conair Parts
(800) 458 1960
From outside of the
United States, call:
(814) 437 6861



Make sure all hoses are securely clamped to prevent wasteful leaking. The hoses should be routed neatly and supported where possible to prevent undue stress on the heater and hopper assemblies. Also, the bends should be made with gradual radiuses. Sharp turns will cause undue pressure drops.

 **NOTE:** Do not allow the flexible hoses to kink or crimp.

Connecting the Dryer to the Heat Source

- 1 Using hard piping or flexible hose, connect the delivery air outlet to the inlet of the HTC or GasTrac. If a flexible hose is used, make sure it is securely clamped.

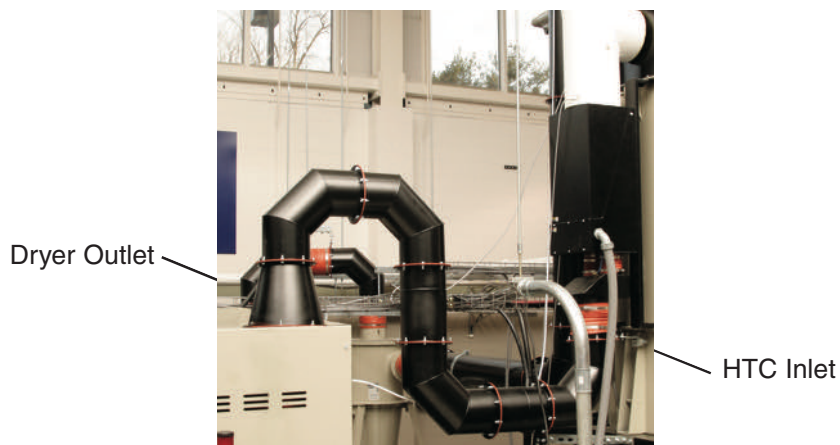

(Dryer Connection to HTC Shown)

Make sure all hoses are securely clamped to prevent wasteful leaking. The hoses should be routed neatly and supported where possible to prevent undue stress on the heater and hopper assemblies. Also, the bends should be made with gradual radiuses. Sharp turns will cause undue pressure drops.

 **NOTE:** Do not allow the flexible hoses to kink or crimp.

An optional hard piping kit for your EnergySmart Dryer system is available from Conair.

Contact Conair Parts
(800) 458 1960
From outside of the
United States, call:
(814) 437 6861

Connecting the Dust Collector (optional)

- 1 Using uninsulated hard piping or flexible hose, connect the optional dust collector outlet to the EnergySmart Dryer return air inlet. If a flexible hose is used, make sure it is securely clamped.

 **NOTE:** Do not allow the flexible hoses to kink or crimp.



Dust
Collector
Outlet

Dryer
Inlet

An optional hard piping kit for your EnergySmart Dryer system is available from Conair.

Contact Conair Parts
(800) 458 1960
From outside of the
United States, call:
(814) 437 6861

Make sure all hoses are securely clamped to prevent wasteful leaking. The hoses should be routed neatly and supported where possible to prevent undue stress on the heater and hopper assemblies. Also, the bends should be made with gradual radiuses. Sharp turns will cause undue pressure drops.

Connecting the Cyclone Separator

(optional)

- 1 Using uninsulated hard piping or flexible hose, connect the cyclone outlet to the optional dust collector inlet or dryer return air inlet. If a flexible hose is used, make sure it is securely clamped.



Outlet to
Dust
Collector

Inlet from
Cyclone

 **NOTE:** Do not allow the flexible hoses to kink or crimp.

Make sure all hoses are securely clamped to prevent wasteful leaking. The hoses should be routed neatly and supported where possible to prevent undue stress on the heater and hopper assemblies. Also, the bends should be made with gradual radiuses. Sharp turns will cause undue pressure drops.

An optional hard piping kit for your EnergySmart Dryer system is available from Conair.

Contact Conair Parts
(800) 458 1960
From outside of the
United States, call:
(814) 437 6861

Installing the Dwyer 641 Air Velocity Transmitter

 **NOTE:** To order Conair's optional hard piping kit for your EnergySmart Dryer System, contact your Conair representative at: US 800-458-1960, International +1-814-437-6861.

The Dwyer 641 Air Velocity Transmitter (AVT) supplied with the EnergySmart Dryer System should be installed within 8 or 12 in. {203.2 or 304.8 mm} customer-supplied pipe using a 5/16 × 1/4 in. NPT compression fitting.

 **IMPORTANT:** The AVT should be installed in a straight piece of pipe, on the return air side of the EnergySmart Dryer. Conair recommends locating the probe toward the end of long straight section of pipe to allow the air flow as much length as possible to straighten out before it comes in contact with the probe. Placing the probe too close to a transition or bend will influence air flow readings.

To install the AVT:

- 1 Determine the best location to install the AVTs following the recommendations above.**
- 2 If Conair's hard piping kit was not purchased with your system, drill and tap customer-supplied 8 or 12 in. {203.2 or 304.8 mm} 2 ft. {0.6 m} long pipe with a 7/16 in. drill bit and 1/4 in. - 18 NPT tap.**

AVT in Dryer Return Air Circuit (Shown with hard piping kit)

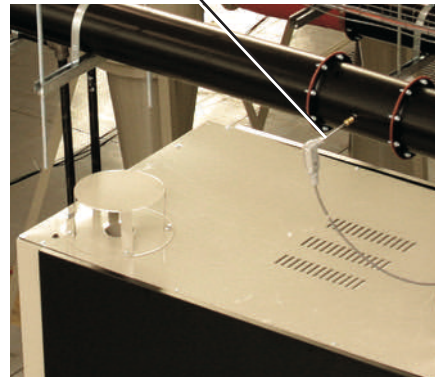

Installing the Dwyer 641 Air Velocity Transmitter (continued)

- 3** Screw the compression fitting into the customer-supplied pipe.
- 4** Orient the air velocity probe so that the flow direction arrow stamped on the NUT used to secure the transmitter is pointing in the direction of the air flow. The arrow is located on the nut below the conduit bodies.

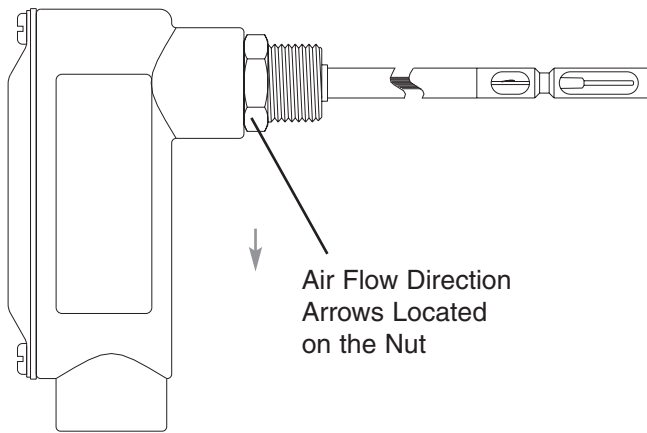

- 5** **Center in pipe.** This will allow you to adjust the air velocity probe in the center of the air stream.

 **NOTE:** Refer to Dwyer 641 Instructions found in the Appendix of this manual.

Installing the Level Switch (optional)

The level switch is installed on the side of the CH Hopper. The level switch's probe will be inserted through the hopper's side wall at the customer desired level to signal the dryer's control to start a loading cycle to refill the hopper.



IMPORTANT: Always refer to the wiring diagrams that came with your level switch before making electrical connections.

- 1 Remove the port plug at the material level that will start a loading cycle with an appropriately-sized Allen wrench.** Several port plugs are located along the side of the CH Hopper.

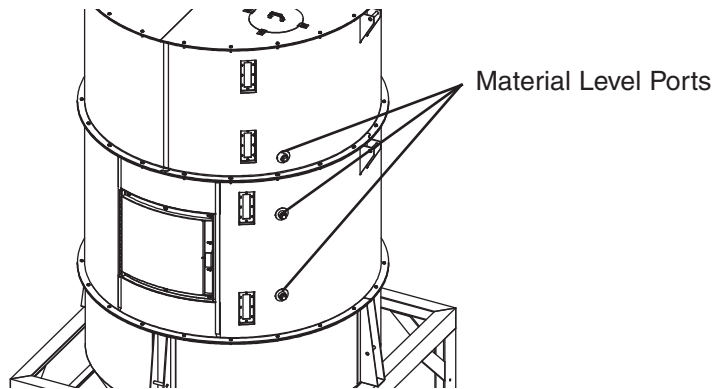

- 2 Locate the level switch.**

- 3 Apply Teflon tape to the installation threads of the level switch.**

- 4 Insert the level switch into the material port selected in Step 1.**

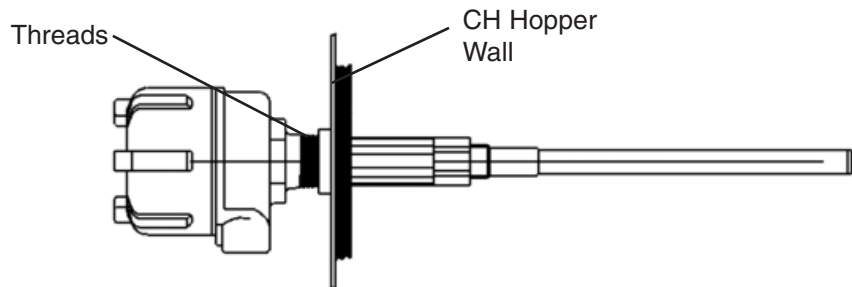

- 5 Install the level switch by rotating the probe and engaging the threads in Step 3, using an appropriately-sized wrench.**

- 6 Connect the wiring to the level switch as detailed in the supplied wiring diagram.**

Adjusting the Level Sensor (optional)

The level sensor should be adjusted both with ambient temperature and with operation temperature. Refer to the instruction manual that came with your level sensor for further detail. To calibrate the unit:

- 1 Turn both the COARSE and FINE potentiometers fully counter-clockwise.**
The COVERED internal indicator light should be off.

- 2 Turn the COARSE potentiometer slowly clockwise to the point where the COVERED indicator light just turns on and says on.**

- 3 Turn the FINE potentiometer slowly clockwise until the COVERED indicator light just turns OFF.** (If the course potentiometer has been carefully adjusted, this should occur when the fine potentiometer is between the 8 and 10 o'clock positions.)
Now continue to turn the FINE potentiometer clockwise to the desired sensitivity setting.
High sensitivity: 1/16 turn
Medium sensitivity: 1/8 turn
Low sensitivity: 1/4 to 1/2 turn

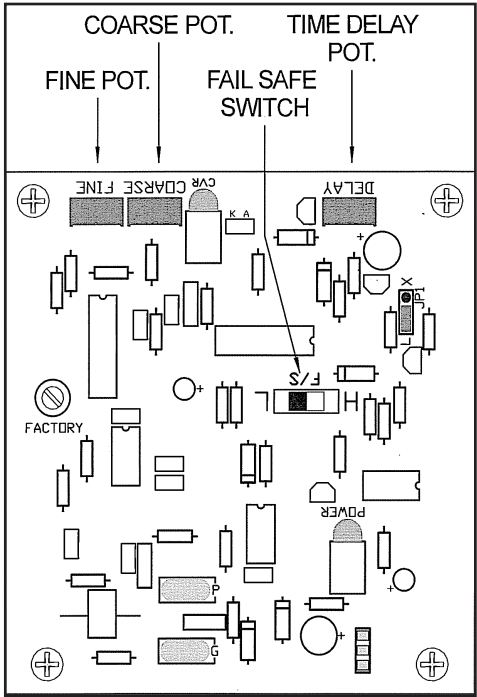

! IMPORTANT: The calibration potentiometers are delicate electronic devices. Do not use excessive force when adjusting.

NOTE: It may be convenient to think of the FINE potentiometer as a clock face and envision the distance between consecutive hour numbers. Turning the FINE potentiometer clockwise one hour position past the point at which the covered indicator just turns off would provide a high sensitivity setting. Two hour positions past that point would provide a medium sensitivity setting.

Installing the Process Protection RTD Sensor (HTC Only)

The process protection RTD probe is a safety sensor that prevents the HTC's heater from overheating in case of a process temperature sensor failure or insulated hose failure.

The process protection RTD sensor senses the temperature leaving the heater assembly to prevent damage to the process or the product within the CH Hopper. It generates an alarm on the HTC control panel (A-49 or A-50) and shuts the heater off if the air temperature exceeds the process protection setpoint. The element for this sensor is to be mounted in the heater assembly outlet nozzle before the insulated hose is connected.

- 1 Insert the process protection RTD probe into the heater assembly outlet nozzle.** Center the end of the probe in the outlet so that the tip does not touch the inlet tube walls.
- 2 Tighten compression fitting of the probe to lock the RTD in place.**
- 3 Route the process protection RTD cable towards the location of the HTC control panel.**

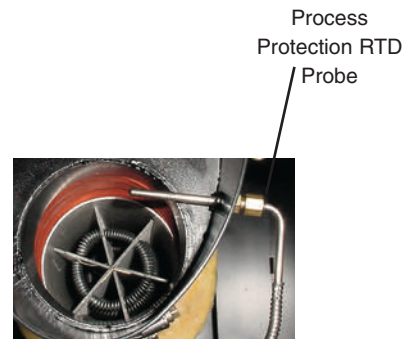

Location of the Process Material Temperature Probe (RTD)

The EnergySmart Dryer control is configured to utilize data from an RTD probe, located within your system, which senses the temperature of the process material leaving the CH Hopper. However, the EnergySmart Dryer System does not provide a location for a material temperature probe. Therefore, the process material temperature probe must be incorporated downstream of the CH Hopper and within your delivery system.

Conair recommends that you check the throat of the machine to which your material is being delivered for an existing tap location that can be used to mount the RTD. If none exists, a second option is to incorporate RTD mounting capabilities into the piping/flange that will connect to the bottom of the CH Hopper after the slide gate.

Conair recommends locating the RTD probe, when possible, within 30 ft {9.15 m} of the EnergySmart Dryer.

 **NOTE:** If the length of the supplied RTD cable is too short for your installation, route the cable into a junction box then connect additional twisted pair wire cable of the appropriate length. Route the added cable to the EnergySmart Dryer control panel.

Junction boxes are available from Conair.

Contact Conair Parts
(800) 458 1960
From outside of the
United States, call:
(814) 437 6861

Installing the RTD Sensor

The RTD sensor monitors the temperature of the drying air as it enters the CH Hopper. If the probe is not installed correctly, temperature readings will be inaccurate.

- 1** Insert the probe into the air inlet port of the CH Hopper. The end of the probe must not touch the walls of the inlet pipe.
- 2** Tighten the compression fitting to lock the RTD probe in place.
- 3** Route the GasTrac RTD cable towards the location of the GasTrac control panel.

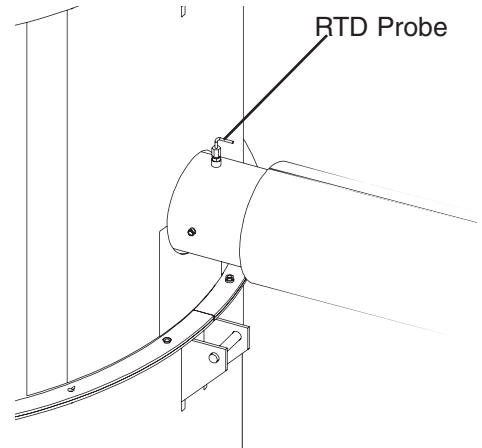

Installing the Return Air Dew Point Line

The return air dew point line allows the dehumidifying dryer to monitor the moisture contained in the air leaving the CH Hopper via the dry air return port. If the line is not installed correctly, dew point readings will be inaccurate.

1 Install the dew point line fitting into the port located at the dry air return circuit as it leaves the CH hopper and before it enters the optional cyclone.

2 Connect the supplied short (3 to 4 ft {0.9 to 1.2 m}) copper tube to the dew point line fitting. Route the copper tube down towards the EnergySmart Dryer. The copper tube is needed to dissipate heat from the sample air.

3 Connect the supplied Teflon® tubing to the end of the copper tube using the compression fitting supplied. Route the Teflon tubing towards the Return Air Dew Point fitting on the back of the EnergySmart Dryer.

4 Cut the supplied Teflon tubing to the proper length.

5 Connect the Teflon tubing to the Return Air Dew Point fitting on the back of the EnergySmart Dryer.

 **NOTE:** The small fitting to the left of the Return Air dew point fitting on the back of the dryer allows the dew point to be checked with a hand held device.

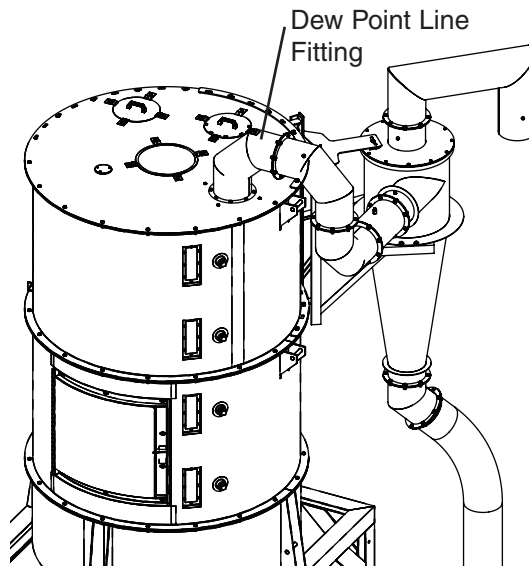

Installation - Main Power Connections

Connecting Main Power to the Dryer



CAUTION: Always disconnect and lock out the main power sources before making electrical connections. Electrical connections should be made only by qualified personnel.

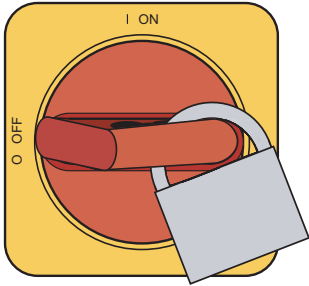

IMPORTANT: Always refer to the wiring diagrams that came with your EnergySmart Dryer before making electrical connections.

- 1 Open the dryer's electrical enclosure.** Turn the disconnect dial on the dryer door to the Off or "O" position. Turn the captive screw and swing the door open.
- 2 Insert the main power wire through the knockout in the side of the enclosure or the rear of the dryer** (the dryer's electrical wire connection location was a factory option and may be connected through the front or the rear of the dryer). Secure the wire with an appropriately-sized strain relief.
- 3 Connect the power wires to the three (3) terminals at the top of the power disconnect holder.**

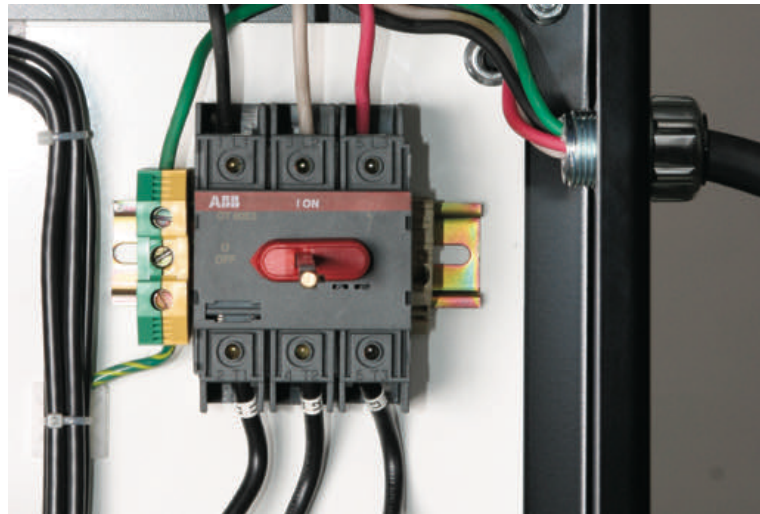

- 4 Connect the ground wire to the ground lug as shown in the photo.**

Connecting Main Power to the HTC (Models HTC 30, 60, 90 and 120)

The electrical connection for the HTC models 30, 60, 90 and 120 only consists of bringing power to the control center. The incoming power should match the rated nameplate power required on the serial tag on the control center. *See Description section entitled, Specifications: Hopper Temperature Controller (HTC).* This power should be clean and have a voltage variation of no more than +/- 5% of the nameplate voltage. Unless the actual voltage is equal to the nameplate voltage, the actual kW output of the HTC will vary slightly. The output varies with the square of the voltage difference.



CAUTION: Always disconnect and lock out the main power sources before making electrical connections. Electrical connections should be made only by a qualified technician.



CAUTION: Check the disconnect with a volt meter to ensure that the power is off.

- 1 Disconnect and lock out the main power before making electrical connections.** Electrical connections should be made only by a qualified technician.
- 2 Turn the disconnect dial on the control center door to the Off or “O” position.** Turn the captive screw and swing the control center door open.
- 3 Insert the main power cable** through a knockout in the side of the control center. Secure the power cable with an appropriately-sized strain relief or use customer-supplied conduit. Verify that the incoming power is securely attached to the control center and there is no strain on the incoming power.
- 4 Connect the power wires** to the three terminals at the top of the power disconnect holder.
- 5 Connect the ground wire** to the ground lug.



IMPORTANT: Always refer to the wiring diagrams that came with your HTC before making electrical connections.

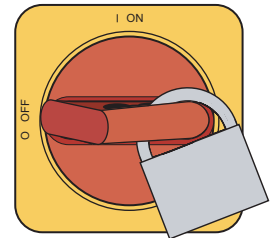

(continued)

Connecting Main Power to the HTC

(continued)

(Models HTC 180 and 270)



IMPORTANT: Always refer to the wiring diagrams that came with your HTC before making electrical connections.

The electrical connection consists of bringing power into the control center and wiring the power from the control center to the heater assembly. The incoming power should match the rated nameplate power required on the serial tag on the control center. *See Description section entitled, Specifications: Hopper Temperature Controller (HTC).* This power should be clean and have a voltage variation of no more than $\pm 5\%$ of the nameplate voltage. Unless the actual voltage is equal to the nameplate voltage, the actual kW output of the HTC will vary slightly. The output varies with the square of the voltage difference.



CAUTION: Always disconnect and lock out the main power sources before making electrical connections. Electrical connections should be made only by a qualified technician.



CAUTION: Check the disconnect with a volt meter to ensure that the power is off.

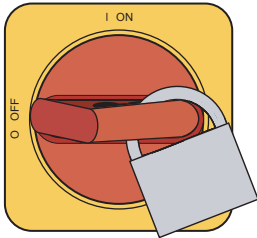

1 Disconnect and lock out the main power before making electrical connections. Electrical connections should be made only by a qualified technician.

2 Turn the disconnect dial on the control center door to the Off or “O” position. Turn the captive screw and swing the control center door open.

3 Insert the main power cable through a knockout in the side of the control center. Secure the power cable with an appropriately-sized strain relief or use customer-supplied conduit. Verify that the incoming power is securely attached to the control center and there is no strain on the incoming power.

4 Connect the power wires to the three terminals at the top of the power disconnect holder.

5 Connect the ground wire to the ground lug.



NOTE: The connection between the heater and control center should be made with properly-sized conductors and protected with appropriate conduit (customer supplied). The routing should be neat and away from potential mechanical damage. The terminations should be landed on the terminals in the control center and heater junction area. These terminations should be regularly checked to prevent loosening and shorting to ground.

Connecting Main Power to the HTC

(continued)

(Models HTC 180 and 270) (continued)

- 6 Insert the customer-supplied heater power wire through a knockout in the side or bottom of the control center. Secure the wire with an appropriately-sized strain relief, if conduit is not used.
- 7 Connect the heater power wires to the control center's terminal block and heater ground wire to the ground lug, as shown.



IMPORTANT: Always refer to the wiring diagrams that came with your HTC before making electrical connections.



Power Wires
(Gray - Customer
Supplied)

Ground Wires
(Green - Customer
Supplied)

- 8 Insert the other end of heater power wire through the knockout in the side of the heater assembly. Secure the wire with an appropriately-sized strain relief, if conduit is not used.
- 9 Connect the heater power wires to the top terminals of the heater assembly's terminal block and heater ground wires to the ground lug, as shown.

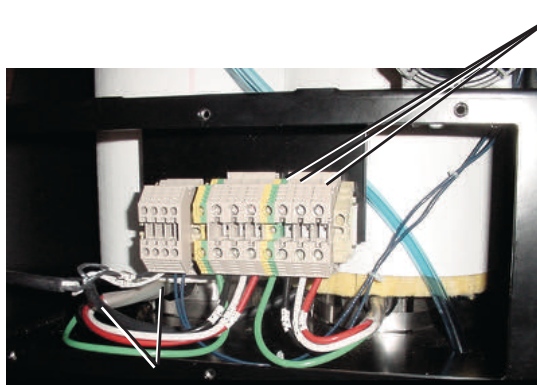

Insert the Power
Wires Here

Ground Wires
(Green/Yellow)

Connecting Main Power to the GasTrac

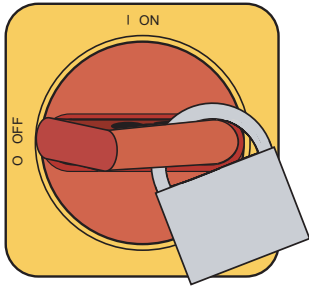

 **IMPORTANT:** Always refer to the wiring diagrams that came with the GasTrac before making electrical connections.

1 Open the GasTrac electrical enclosure. Turn the disconnect dial on the GasTrac's door to the Off or "O" position. Turn the captive screw, and swing the door open.



CAUTION: Electrical Hazard. Always disconnect and lock out the main power sources before making electrical connections. Electrical connections should be made only by qualified personnel.

2 Insert the main power wire through the knockout in the electrical enclosure. Secure the wire with an appropriately-sized relief.

3 Connect the power wires to the three (3) terminals at the top of the disconnect holder.

4 Connect the ground wire to either grounding point shown in the diagram.

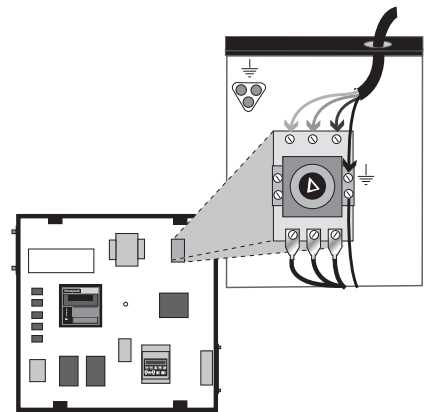

Connecting Main Power to the Vacuum Pump(s) (optional)

1 Connect power. Refer to the accompanying wiring diagram for connection of the main power supply. **IMPORTANT: You must provide a wall-mounted disconnect for three-phase electrical connection. Incoming voltage and current must match the electrical specifications on the pump data plate and serial tag.**



IMPORTANT: Always refer to the wiring diagrams that came with the vacuum pump(s) before making electrical connections.



WARNING: This equipment should be installed, adjusted, and serviced by qualified technical personnel who are familiar with the construction, operation and potential hazards of this type of machine. All wiring, disconnects and fuses should be installed by qualified electrical technicians in accordance with electrical codes in your region. Always maintain a safe ground. Do not operate the equipment at power levels other than what is specified on the the machine serial tag and data plate.

2 Check for proper rotation of the pump after power has been connected and before operation.

Connecting Main Power to the Dust Collector(s) (optional)

Proper operation of the optional dust collector depends upon its internal vacuum valve opening whenever the vacuum pump is energized. Electrical connections are provided by a 3-conductor cable connected to the dust collector. This cable should be connected to the vacuum pump control enclosure to provide simultaneous operation of the dust collector when the pump is activated. On automatic unload/reload dust collectors, the cable is attached to the reload control enclosure, which distributes power to the various solenoids for the auto reload function of the dust collector.



IMPORTANT: Always refer to the wiring diagrams that came with the dust collector(s) before making electrical connections.

Installation - Conveying Lines

Connecting the Conveying Lines to the Receiver(s) (optional)

If an optional receiver is mounted to the top of the CH Hopper, follow the instructions supplied with the receiver to connect the conveying lines. Also refer to the receiver's installation instructions and operations manual for power, level switch and compressed air connections/specifications.

If a secondary optional receiver is to be used, follow the instructions supplied with the receiver to connect the conveying lines. Also refer to the receiver's installation instructions and operations manual for power, level switch and compressed air connections/specifications

Connecting the Conveying Lines to the Purge Valve(s) (optional)

If a purge valve is to be mounted to the bottom of the CH Hopper or auxiliary hopper follow the installation instructions, specifications, and wiring diagrams supplied with the valve. Also refer to the purge valve's installation instructions and operations manual for power, compressed air connections/specifications.

Connecting the Conveying Lines to the Vacuum Pump(s) and Dust Collector(s) (optional)

- 1 Connect the vacuum line from the optional receiver to the air inlet of the optional dust collector.
- 2 Connect the vacuum line from the dust collector's air outlet to the vacuum pump's air inlet.
- 3 Repeat Steps 1 and 2 if a second optional receiver, dust collector and vacuum pump are to be used.

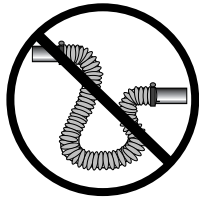
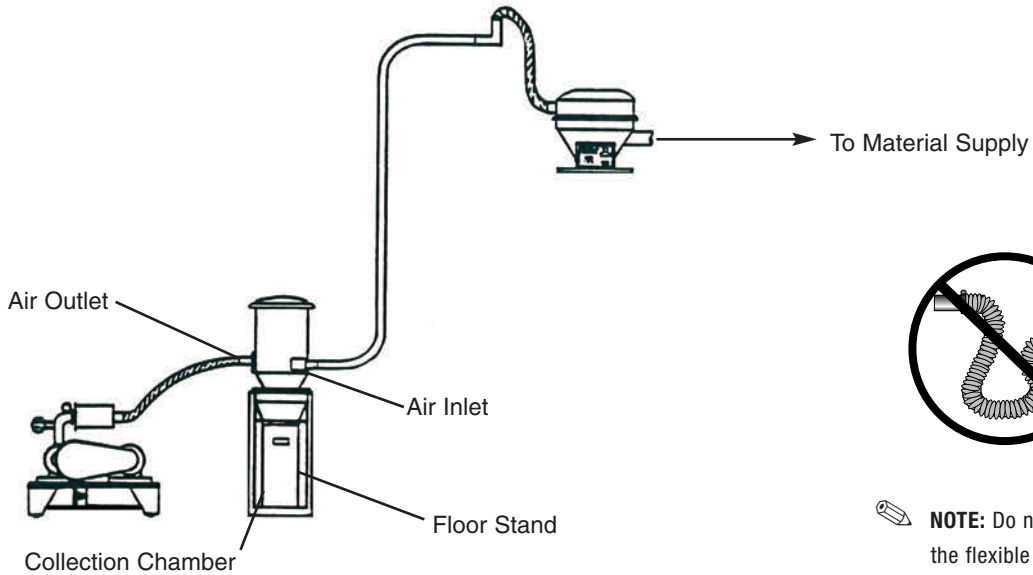

NOTE: Do not allow the flexible hoses to kink or crimp.

NOTE: Vacuum pump shown above is 180° out of position.

Make sure all hoses are securely clamped to prevent wasteful leaking. The hoses should be routed neatly and supported where possible to prevent undue stress. Also, the bends should be made with gradual radiuses. Sharp turns will cause undue pressure drops.

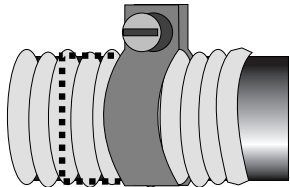

Installation - Water Lines

Typical Water Lines Installation Drawing

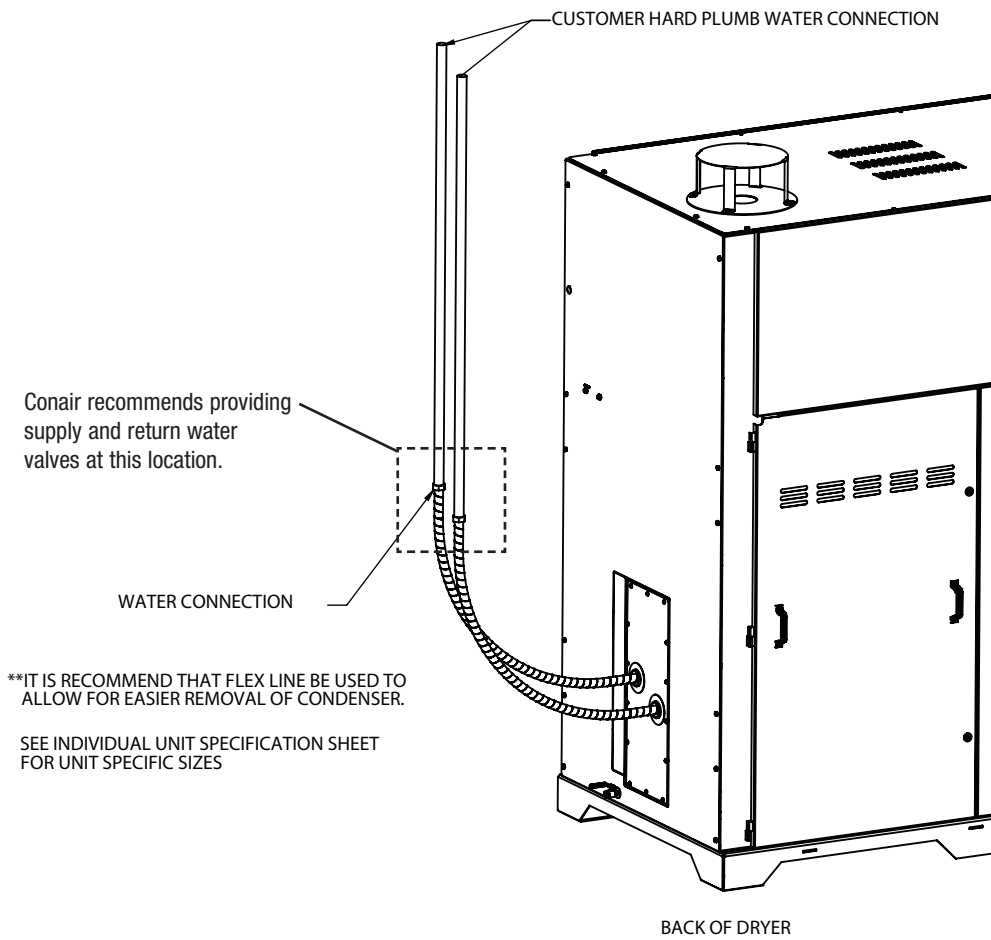

Connecting the Aftercooler/ Intercooler and Optional Precooler

(W600 - 1000)

The aftercooler and/or optional precooler require a source of city, tower, or chiller water and a discharge or return line. You can use water at temperatures of 45 to 85°F {7 to 29°C}.

◆ **TIP:** Make the water supply and discharge / return connections with flexible hoses at least 24 in. (61 cm) long. This allows you to easily remove the aftercooler/intercooler assembly for cleaning.

◆ **TIP:** If an optional flow control is also being installed with the aftercooler/intercooler, the manual shut off valve should be installed on the inlet line for the flow control.

✎ **NOTE:** Models W600-1000 dryer aftercooler/intercooler and dry air delivery configuration shown. Location on larger models are different. Refer to the labeling on your dryer.



Aftercooler/Intercooler Inlet

1 Connect the water supply line to the aftercooler/intercooler or precooler inlet. If a manual shut off valve is used, it should be mounted on the inlet line.



Aftercooler/Intercooler Outlet

2 Connect the water discharge or return line with the pressure relief valve to the aftercooler/intercooler or precooler outlet. Use the bracket supplied to secure the pressure relief valve to the back of the dryer.

⚠ **IMPORTANT:** Turn the water off when the dryer is not in use to prevent condensation.

Recommended Water Flow Rates	
Dryer Model	gal./min. {liters/min.}
600	15 {56.8}
800	15 {56.8}
1000	20 {75.7}
1600	25 {94.6}
2400	25 {94.6}
3200	30 {113.6}
5000	30 {113.6}

Connecting the Intercooler and Optional Precooler (W1600 - 5000)

The intercooler and/or optional precooler require a source of city, tower, or chiller water and a discharge or return line. You can use water at temperatures of 45 to 85°F {7 to 29°C}.

❖ **TIP:** Make the water supply and discharge / return connections with flexible hoses at least 24 in. (61 cm) long. This allows you to easily remove the aftercooler/intercooler assembly for cleaning.

❖ **TIP:** If an optional flow control is also being installed with the aftercooler/intercooler, the manual shut off valve should be installed on the inlet line for the flow control.

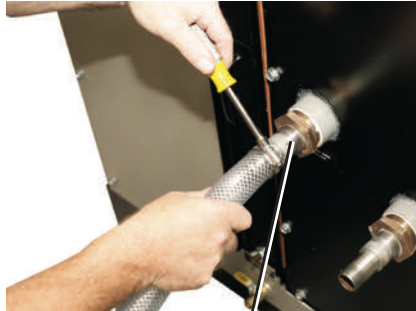

Aftercooler/Intercooler Inlet

1 Connect the water supply line to the aftercooler/intercooler or precooler inlet. If a manual shut off valve is used, it should be mounted on the inlet line.



Aftercooler/Intercooler Outlet

2 Connect the water discharge or return line with the pressure relief valve to the aftercooler/intercooler or precooler outlet. Use the bracket supplied to secure the pressure relief valve to the back of the dryer.

Recommended Water Flow Rates	
Dryer Model	gal./min. {liters/min.}
600	15 {56.8}
800	15 {56.8}
1000	20 {75.7}
1600	25 {94.6}
2400	25 {94.6}
3200	30 {113.6}
5000	30 {113.6}



IMPORTANT: Turn the water off when the dryer is not in use to prevent condensation.

Installation - Control & Communication Wiring

Wiring the HTC (Electric Process Heater) to the HTC Controller

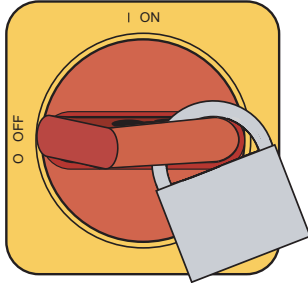

! **IMPORTANT:** Always refer to the wiring diagram that came with your HTC before making electrical connections.

! **IMPORTANT:** Always refer to the proper wiring diagram supplied with your equipment before making electrical connections.

! **CAUTION:** Always disconnect and lock out the main power sources before making electrical connections. Electrical connections should be made only by qualified personnel.

- 1 Refer to the wiring diagram that came with your control.**
- 2 Insert the control wires through a knockout in the side or bottom of the HTC control center.** Secure with an appropriately-sized strain relief, if conduit is not used.
- 3 Connect the high temperature and pressure switch wires to the control center's terminal block.**
- 4 Insert the other end of the control wires through the knockout in one side of the HTC heater assembly terminal box.** Secure with an appropriately-sized strain relief, if conduit is not used.
- 5 Connect the high temperature and pressure switch wires to the heater assembly terminal block.**

! **IMPORTANT:** The connection between the heater and control center should be made with customer supplied wire that has properly sized conductors and properly protected with customer-supplied conduit. The routing should be neat and away from potential mechanical damage. The terminations should be landed on the terminals in the control center and heater junction area. These terminations should be regularly checked to prevent loosening and shorting to ground.

Connecting the HTC to the HTC Controller (continued)

- 6** Insert the heater power wire through a knockout in the side or bottom of the HTC control center. Secure the wire with an appropriately-sized strain relief, if conduit is not used.
- 7** Connect the heater power wires to the control center's terminal block and heater ground wire to the ground lug as shown.

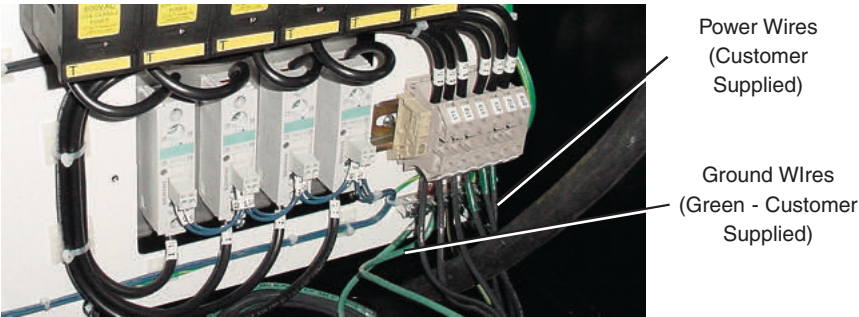

- 8** Insert the other end of heater power wire through the knockout in the side of the heater assembly. Secure the wire with an appropriately-sized strain relief, if conduit is not used.
- 9** Connect the heater power wires to the top terminals of the heater assembly's terminal block and heater ground wires to the ground lug as shown.

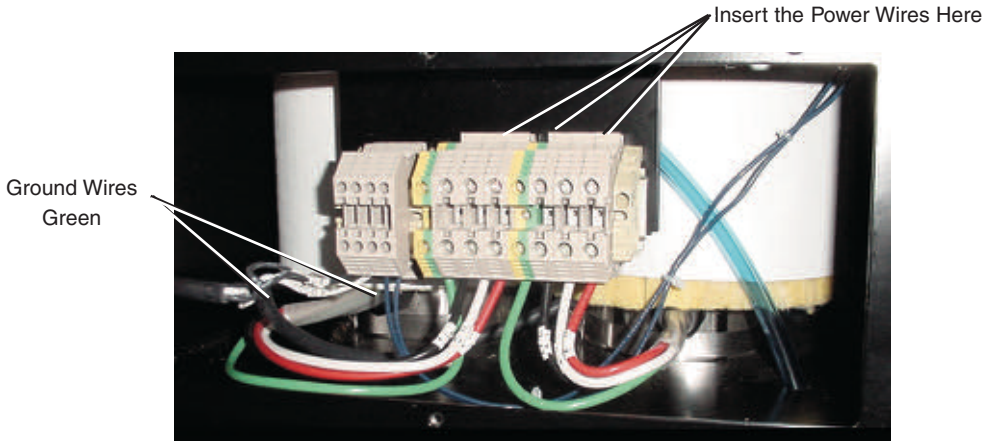

Connecting the RTD Sensors (HTC only)



IMPORTANT: Always refer to the wiring diagrams that came with your HTC before making electrical connections.

The routing of the RTD sensor cables should be neat and not parallel with the power connections. When a sensor cable must cross over power wiring, the intersection should be made at right angles (90 degree) to reduce the RFI noise transmitted to the sensor cable.

Process Temperature RTD Probe

The process RTD sensor connection should be made to the HTC's control panel



CAUTION: Always disconnect and lock out the main power sources before making electrical connections. Electrical connections should be made only by qualified personnel.

- 1 Disconnect and/or lock out main power to the HTC.**
- 2 Route the process temperature RTD cable from hopper inlet to the HTC's control panel.** Plug the connector into receptacle in the side of the control center labeled "Process". Hand tighten the connector. Coil any excess cable and secure it with a wire tie.



Process Protection RTD Probe

The process protection RTD probe is a safety sensor that prevents the HTC's heater from overheating in case of a process temperature sensor failure or insulated hose failure.

The process protection RTD sensor senses the temperature leaving the heater assembly to prevent damage to the process or the product in the CH Hopper. It generates an alarm (A-49 or A-50) at the HTC control panel and shuts the heater off if the air temperature exceeds the process protection setpoint. The element for this sensor is to be mounted in the heater assembly outlet nozzle before the insulated hose is connected.

Connecting the RTD Sensors (HTC only)

(continued)

Process Protection RTD Probe (continued)



CAUTION: Always disconnect and lock out the main power sources before making electrical connections. Electrical connections should be made only by qualified personnel.

1 Disconnect and/or lock out main power to the HTC.

2 Route the process protection RTD cable from hopper inlet to the HTC control panel. Plug the connector into the receptacle in the side of the control center labeled “Process Protection”. Hand tighten the connector. Coil any excess cable and secure it with a wire tie.

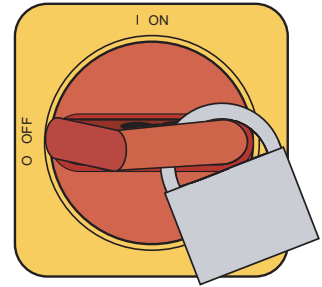

IMPORTANT: Always refer to the wiring diagrams that came with your HTC before making electrical connections.

Connecting the GasTrac RTD Sensor

 **IMPORTANT:** Always refer to the wiring diagrams that came with your GasTrac before making electrical connections.

The GasTrac RTD sensor monitors the temperature of the drying air as it enters the CH Hopper. If the probe is not installed correctly, temperature readings will not be inaccurate.

 **CAUTION:** Always disconnect and lock out the main power sources before making electrical connections. Electrical connections should be made only by qualified personnel.

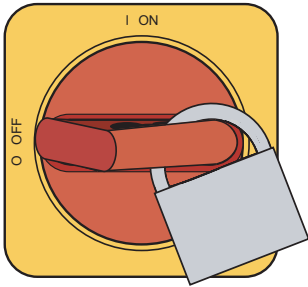

1 Disconnect and/or lock out main power to the GasTrac.

2 Route the GasTrac RTD cable to the GasTrac control center.

3 Plug the RTD cable into the GasTrac control center. Coil any excess cable and secure with a wire tie.

 **NOTE:** Conair recommends locating the RTD probe, when possible, within 30 ft {9.15 m} of the GasTrac control center.

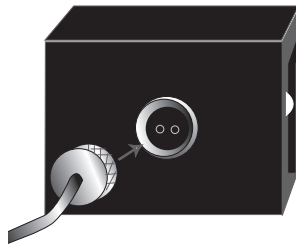

Connecting the Drying Monitor Probe to the Dryer

From the Top of the CH Hopper

 **IMPORTANT:** Always refer to the wiring diagrams that came with your Drying Monitor before making electrical connections.

- 1** Connect the cable supplied with the DM probe to the receptacle in the top of the probe.

DM Cable Connection at the Probe

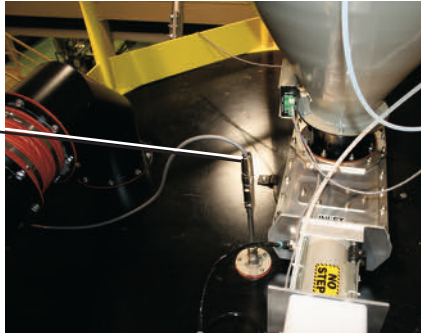

- 2** Route the DM cable from the DM probe to the side of the EnergySmart Dryer's electrical enclosure.
- 3** Connect the DM cable to the DM cable receptacle on the side of the EnergySmart Dryer's electrical enclosure.

Connecting the Receiver to the Level Switch (optional)



IMPORTANT: Always refer to the wiring diagrams that came with your optional level switch and receiver before making electrical connections.

Refer to your specific receiver's manual for instructions to connect the level switch. The level switch sensor monitors the amount of material inside and indicates to a receiver that a load cycle is required. If the probe is not installed correctly, material level readings will be inaccurate.



CAUTION: Always disconnect and lock out the main power sources before making electrical connections. Electrical connections should be made only by qualified personnel.

Connecting the EnergySmart Dryer Control to System Components

 **WARNING:** The EnergySmart Dryer **DOES NOT** have a central power switch to disconnect and lock out the main power to the system components. The power **MUST BE** disconnected and locked out at each system component.

 **IMPORTANT:** Always refer to the wiring diagrams that came with your EnergySmart Dryer and individual components before making electrical connections.

 **CAUTION:** Always disconnect and lock out the main power sources before making electrical connections. Electrical connections should be made only by qualified personnel.

There are two (2) types of connections between the EnergySmart Dryer control and the components of the system:

- Control system inter-connecting wiring
- Communications inter-connecting wiring

The control system inter-connecting wiring consists of 24 VDC connections necessary for the EnergySmart Dryer control to operate the system components.

The communications inter-connecting wire is a typical Modbus-485 "daisy chain" used to read data from system components.

 **NOTE:** The communications interconnecting "daisy chain" wire starts at its connection point at the EnergySmart Dryer control, then is connected to the other system components.

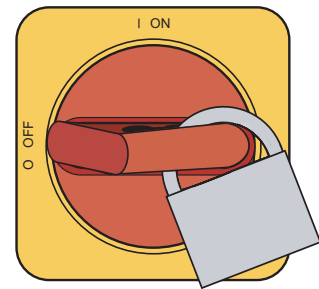

 **NOTE:** All power going out from the EnergySmart control panel to the system components will be 24 VDC.

 **NOTE:** Conair recommends the connections between the EnergySmart Dryer and system components should be made with properly sized conductors and properly protected with appropriate conduit (customer supplied). The routing should be neat and away from potential mechanical damage.

(continued)



IMPORTANT: Always refer to the wiring diagrams that came with your EnergySmart Dryer and GasTrac before making electrical connections.

Connecting the EnergySmart Dryer Control to System Components

(continued)

Connecting the EnergySmart Dryer System Heat Source

The following sections give instructions for wiring the EnergySmart Drying System components. Specific details for wiring your EnergySmart Dryer System components is detailed in the wiring diagrams supplied with your system and the individual components.



IMPORTANT: Always refer to the wiring diagrams that came with your EnergySmart Dryer System and the individual components before making electrical connections.



NOTE: The connections between the EnergySmart electrical panel and the system components should be made with properly-sized conductors and properly protected with appropriate conduit (customer supplied). The routing should be neat and away from potential mechanical damage.

GasTrac As Heat Source



NOTE: If a HTC is used as the heat source in your EnergySmart Dryer System, [see Installation section entitled, Connecting the EnergySmart Dryer Control to System Components, HTC As Heat Source](#)



CAUTION: Always disconnect and lock out the main power sources before making electrical connections. Electrical connections should be made only by qualified personnel.



NOTE: Do not run communication and control wires in the same conduit.

- 1 Disconnect and/or lock out main power** to the EnergySmart Dryer and the GasTrac.
- 2 Open the door of the EnergySmart Dryer electrical panel and determine the location of the entry ports for the control system inter-connecting and the communication inter-connecting wires.**
- 3 Drill or cut the entry ports,** one for the inter-connecting wire and one for the communication inter-connecting wire.
- 3b If using electrical conduit, cut entry ports for both wires and then run customer supplied conduit for each from the EnergySmart Dryer's electrical enclosure to the GasTrac's electrical enclosure.**

Connecting the EnergySmart Dryer Control to System Components

(continued)

- 4** Route the control system inter-connecting and communications inter-connecting wires from the EnergySmart Dryer electrical panel to the GasTrac electrical panel.
- 5** If not using conduit, insert the control system inter-connecting and the communication inter-connecting wires through their respected entry port. Secure the wires with an appropriately-sized strain relief.
- 6** Connect the control system inter-connecting wiring of the GasTrac to the EnergySmart Dryer electrical panel as detailed in the supplied wiring diagram.
- 7** Connect the communication inter-connecting wire of the GasTrac to the EnergySmart Dryer electrical panel as detailed in the supplied wiring diagram.
- 8** If not using conduit, determine the location of the entry port in the GasTrac's electrical enclosure for the control system inter-connecting and the communication inter-connecting wires.
- 9** If not using conduit, drill or cut the entry ports, one for the inter-connecting wire and one for the communication inter-connecting wire.
- 10** If not using conduit, insert the control system inter-connecting and the communications inter-connecting wires for the GasTrac through their respected entry ports on the GasTrac's electrical enclosure. Secure the wires with an appropriately-sized strain relief.
- 11** Connect the control system inter-connecting wires to the GasTrac's electrical panel as detailed in the supplied wiring diagram.
- 12** Connect the communication inter-connecting wire to the GasTrac's electrical panel as detailed in the supplied wiring diagram.



IMPORTANT: Always refer to the wiring diagrams that came with your EnergySmart Dryer and GasTrac before making electrical connections.

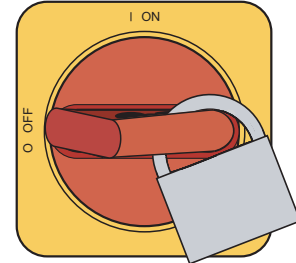



IMPORTANT: Always refer to the wiring diagrams that came with your HTC and EnergySmart system before making electrical connections.

Connecting the EnergySmart Dryer Control to System Components

(continued)

HTC As Heat Source



NOTE: If a GasTrac is used as the heat source in your EnergySmart Dryer System, *see Installation section entitled, Connecting the EnergySmart Dryer Control to System Components, GasTrac As Heat Source.*



CAUTION: Always disconnect and lock out the main power sources before making electrical connections. Electrical connections should be made only by qualified personnel.

- 1** Disconnect and/or lock out main power to the EnergySmart Dryer and the HTC.
- 2** Open the door of the EnergySmart Dryer electrical panel and **determine the location of the entry ports for the control system inter-connecting and the communication inter-connecting wires.**
- 3** **Drill or cut the entry ports,** one for the inter-connecting wire and one for the communication inter-connecting wire.
- 3b** **If using electrical conduit, cut entry ports for both wires and then run customer supplied conduit for each from the EnergySmart Dryer's electrical enclosure to the HTC's electrical enclosure.**
- 4** **Route the control system inter-connecting and communications inter-connecting wires from the EnergySmart Dryer electrical panel to the HTC electrical panel.**
- 5** **If not using conduit, insert the control system inter-connecting and the communication inter-connecting wires through their respected entry port.** Secure the wires with an appropriately-sized strain relief.
- 6** **Connect the control system inter-connecting wiring of the HTC to the EnergySmart Dryer electrical panel** as detailed in the supplied wiring diagram.



NOTE: Do not run communication and control wires in the same conduit.

Connecting the EnergySmart Dryer Control to System Components

(continued)

- 7** Connect the communication inter-connecting wire of the HTC to the EnergySmart Dryer electrical panel as detailed in the supplied wiring diagram.
- 8** If not using conduit, determine the location of the entry port in the HTC's electrical enclosure for the control system inter-connecting and the communication inter-connecting wires.
- 9** If not using conduit, drill or cut the entry ports, one for the inter-connecting wire and one for the communication inter-connecting wire.
- 10** If not using conduit, insert the control system inter-connecting and the communications inter-connecting wires for the HTC through their respected entry ports on the HTC's electrical enclosure. Secure the wires with an appropriately-sized strain relief.
- 11** Connect the control system inter-connecting wires to the HTC's electrical panel as detailed in the supplied wiring diagram.
- 12** Connect the communication inter-connecting wire to the HTC's electrical panel as detailed in the supplied wiring diagram.

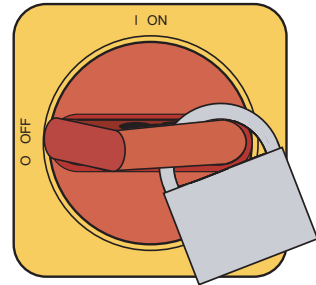

IMPORTANT: Always refer to the wiring diagrams that came with your HTC and EnergySmart system before making electrical connections.

Connecting the EnergySmart Control to System Components

(continued)



IMPORTANT: Always refer to the wiring diagrams that came with your AVT and EnergySmart Dryer before making electrical connections.

Connecting the Air Process Air Flow Transmitter

The EnergySmart Drying System uses data from the Dwyer 641 Air Velocity Transmitter (AVT) for drying process air flow information.



IMPORTANT: Always refer to the wiring diagrams that came with your EnergySmart Dryer System before making electrical connections.



NOTE: Conair recommends the connections between the EnergySmart Dryer and system components should be made with properly sized conductors and properly protected with appropriate conduit (customer supplied). The routing should be neat and away from potential mechanical damage.



CAUTION: Always disconnect and lock out the main power sources before making electrical connections. Electrical connections should be made only by qualified personnel.

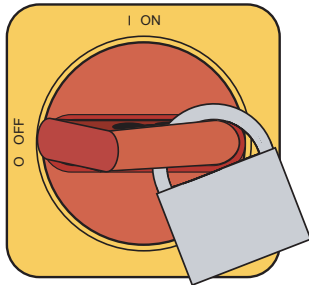

To connect the AVT to the EnergySmart Dryer electrical panel:

- 1** Disconnect and/or lock out main power to the EnergySmart Dryer.
- 2** Route the wires from the AVT to the EnergySmart Dryer electrical panel.
- 3** Determine the location of the entry port on EnergySmart Dryer's electrical panel for the AVT wires. Open the door of the EnergySmart control panel.
- 4** Drill or cut the entry port.
- 4b** If using electrical conduit, cut entry port and then run customer supplied conduit from the EnergySmart Dryer's electrical enclosure to the AVT.
- 5** Insert the AVT wires through the entry port on the dryer's control panel. Secure the wires with an appropriately-sized strain relief.

Connecting the EnergySmart Control Panel to the System Components (continued)

6 Connect the three (3) wires between the air velocity probe and the receiver in the EnergySmart Dryer system electrical panel using the 3-wire receiver negative common diagram as shown. The receiver, in this case, is the Allen-Bradley 1762-IF4 analog input card. Refer to your Dwyer 641 Manual for more detail.

⚠ IMPORTANT: Always refer to the wiring diagrams that came with your AVT and EnergySmart Dryer before making electrical connections.

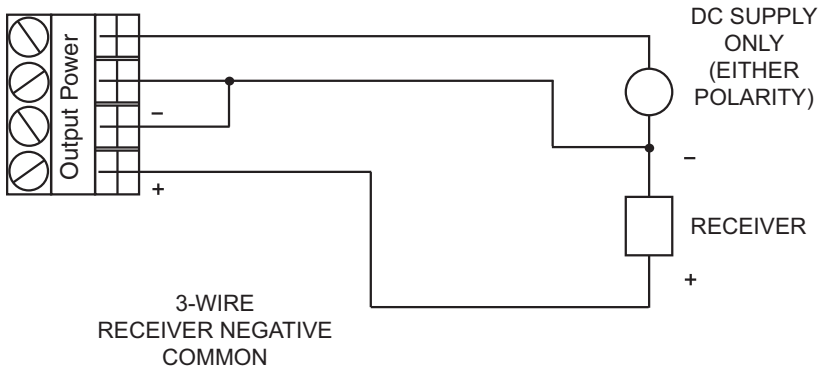

(continued)

Connecting the EnergySmart Control to System Components

(continued)



IMPORTANT: Always refer to the wiring diagrams that came with your vacuum pump and EnergySmart Dryer before making electrical connections.



NOTE: Conair recommends the connections between the EnergySmart Dryer and system components should be made with properly sized conductors and properly protected with appropriate conduit (customer supplied). The routing should be neat and away from potential mechanical damage.

Connecting the Optional Vacuum Pump(s)

The EnergySmart Drying System control sends a start signal to the optional vacuum pump(s) when it receives a load signal from the optional receiver(s) mounted on top of the CH hopper or auxiliary hopper.



CAUTION: Always disconnect and lock out the main power sources before making electrical connections. Electrical connections should be made only by qualified personnel.

To connect the vacuum pump to the EnergySmart Dryer electrical panel:

- 1 Disconnect and/or lock out main power to the EnergySmart Dryer and vacuum pump.**
- 2 Determine the location of the entry port on EnergySmart Dryer's electrical panel for the vacuum pump wires.** Open the door of the EnergySmart control panel.
- 3 Drill or cut the entry port.**
- 3b If using electrical conduit, cut entry port and then run customer supplied conduit from the EnergySmart Dryer's electrical enclosure to the vacuum pump.**
- 4 Insert the pump wires through the entry port on the dryer's control panel.** Secure the wires with an appropriately-sized strain relief.
- 5 Connect the wiring to vacuum pump** as detailed in the supplied wiring diagram.
- 6 Connect the wiring of the vacuum pump to the EnergySmart Dryer electrical panel** as detailed in the supplied wiring diagram.
- 7 Repeat the procedure above when adding an additional vacuum pump.**

Connecting the EnergySmart Control to System Components

(continued)

Connecting the Optional Receiver(s)

The EnergySmart Drying System can operate up to two (2) optional material receivers. Load time, dump time and purge time can all be altered within the EnergySmart Dryer control.

 **CAUTION:** Always disconnect and lock out the main power sources before making electrical connections. Electrical connections should be made only by qualified personnel.

To connect the receiver to the EnergySmart Dryer electrical panel:

- 1 Disconnect and/or lock out main power to the EnergySmart Dryer and receiver.**
- 2 Route the wires for the receiver to the EnergySmart Dryer electrical panel.**
- 3 Open the door of the EnergySmart control panel and determine the location of the entry port on the dryer's control panel for the receiver wiring.**
- 4 Drill or cut the entry port.**
- 4b If using electrical conduit, cut the entry port and then run customer supplied conduit from the EnergySmart Dryer's electrical enclosure to the receiver.**
- 5 If using electrical conduit, insert the wiring for the receiver through the entry port on the dryer's electrical panel. Secure the wires with an appropriately-sized strain relief.**
- 6 Connect the wiring to receiver as detailed in the supplied wiring diagram.**
- 7 Connect the wiring for the receiver to the dryer's electrical panel as detailed in the supplied wiring diagram.**
- 8 Repeat the procedure above when adding an additional receiver.**

(continued)

 **IMPORTANT:** Always refer to the wiring diagrams that came with your optional receiver(s) and EnergySmart Dryer before making electrical connections.

 **NOTE:** Conair recommends the connections between the EnergySmart Dryer and system components should be made with properly sized conductors and properly protected with appropriate conduit (customer supplied). The routing should be neat and away from potential mechanical damage.

Connecting the EnergySmart Control to System Components

(continued)

Connecting the Air Pressure Sensor

 **IMPORTANT:** Always refer to the wiring diagrams that came with your sensor and EnergySmart Dryer before making electrical connections.

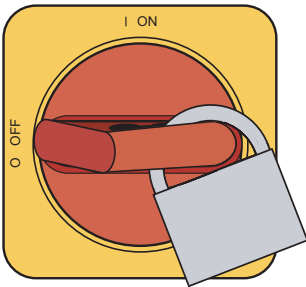

The EnergySmart Drying System uses data from the Dwyer 616 Differential Pressure Transmitter (DPTs) installed on one leg of the optional dust collector for drying air pressure information.

 **CAUTION:** Always disconnect and lock out the main power sources before making electrical connections. Electrical connections should be made only by qualified personnel.

To connect the DPT to the EnergySmart Dryer electrical panel:

- 1** Disconnect and/or lock out main power to the EnergySmart Dryer.
- 2** Route the wires for the air pressure sensor to the EnergySmart Dryer electrical panel.
- 3** Open the door of the EnergySmart control panel and **determine the location of the entry port on the dryer's control panel for the control system interconnecting wires of the air pressure sensor.**
- 4** Drill or cut the entry port.
- 4b** If using electrical conduit, cut the entry port and then run customer supplied conduit from the EnergySmart Dryer's electrical enclosure to the sensor.
- 5** If using electrical conduit, insert the wiring for the air pressure sensor through the port in the dryer's control panel. Secure the wires with an appropriately-sized strain relief.
- 6** Connect the wiring for the air pressure sensor to the dryer's electrical panel as detailed in the supplied wiring diagram.



NOTE: On systems without a Dust Collector, the air pressure transmitter is inside the dryer.

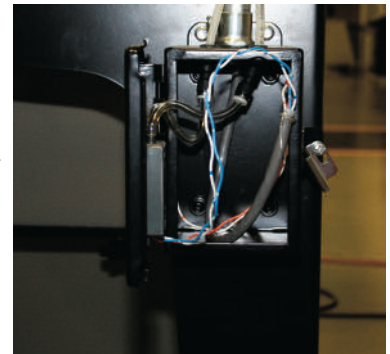

Installation - Compressed Air Lines

Connecting the Compressed Air Lines (optional)

If individual components require compressed air, follow the instructions supplied with the equipment to connect the compressed air lines. Also refer to the component's installation instructions and operation manuals for power and compressed air connections/specifications.

EnergySmart Dryer System components that require compressed air:

- Receiver(s)
- Adjustable Purge Valve (APV) or Pocket valve
- Knife gate(s)
- Dust collector(s) - with conveying circuits

Installation - Gas Piping and Exhaust Flue (GasTrac only)

Typical Gas Line Installation Drawing

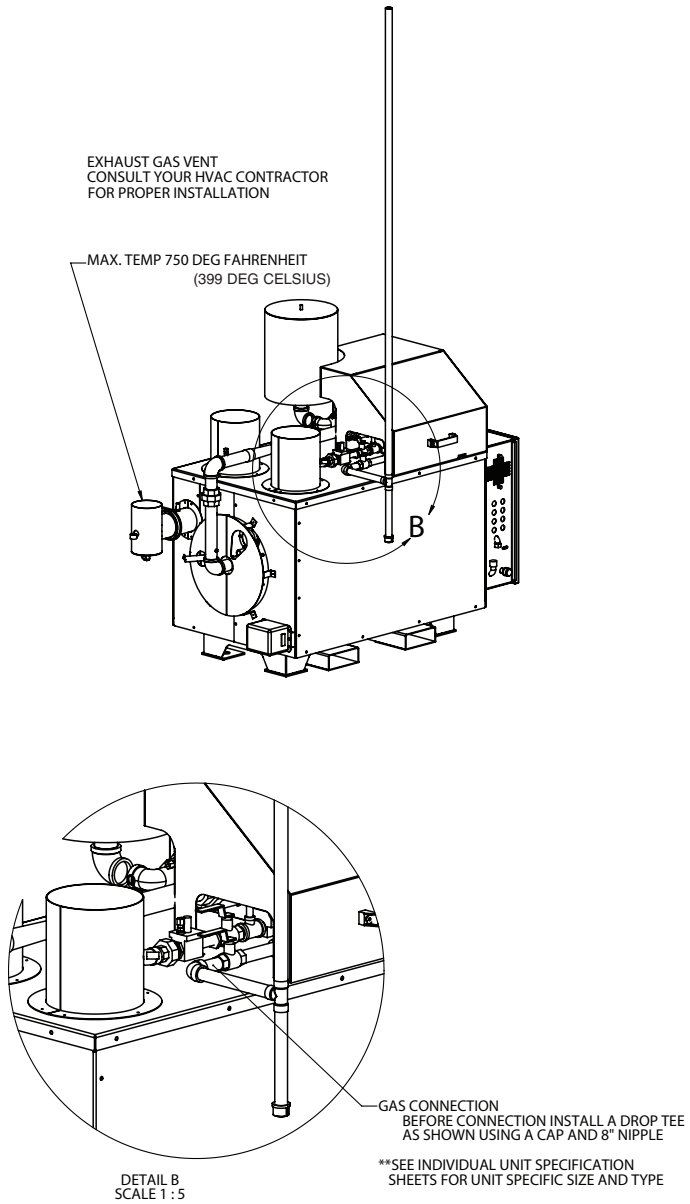

Installing the Conair GasTrac

Gas Line Sizing

Conair recommends that the customer contact a local contractor that can determine the gas line size based on specific conditions.

The information below will be required for the contractor or gas supplier to make the proper gas line selection:

- 1** The required inlet gas pressure to the GasTrac’s regulator must be less than 5 psig. Also, the incoming gas pressure should not vary more than 5" H₂O between no gas flow and maximum gas flow. The regulator on the GasTrac can be used to adjust the supplied gas pressure to 7" H₂O.
- 2** If an additional regulator is required to obtain the proper delivery gas pressure (1 to 5 psig), the regulator must have an **ANSI Class 6 positive shut off** to prevent gas pressure increase when the GasTrac is turned off.

The following chart is a listing of the maximum gas usage and inlet line size used on each GasTrac.

GasTrac Model	Max Gas Flow (CFH) {CMH}	Inlet Line Size (NPT)
CGT150	150 {4.2}	3/4 in.
CGT250	250 {7.1}	3/4 in.
CGT350	350 {9.9}	3/4 in.
CGT500	500 {14.1}	3/4 in.
CGT700	700 {19.8}	1 in.

 **NOTE:** Conair strongly recommends that a “drop tube” be utilized when piping the gas line into the GasTrac. This will help to prevent any oil or metal shavings, created during the installation process, from entering the GasTrac. If this action is not completed, warranty on components in gas line will be voided.

(continued)

Installing the Conair GasTrac

(continued)

Proper Exhaust Recommendations

Conair recommends that the customer contact a local contractor that can determine the proper line size based on specific conditions.

The following information may be required for the contractor to make a proper exhaust selection:

- 1** The addition of exhaust ducting to the GasTrac combustion flue stack must not decrease the CFM {CMH} by more than 10%.
- 2** The use of a booster blower (if applied) at the end of a duct run should not increase the combustion exhaust air flow by more than 10%.
- 3** In order to ensure that Steps 1 and 2 above are not exceeded, the CFM {CMH} of the combustion exhaust should be checked prior to the addition of the exhaust stack. After adding the exhaust stack, the CFM {CMH} should be rechecked to ensure that the air flow is within the guidelines. The GasTrac should not be ran for long periods of time without being properly connected to the exhaust ducting, directing flue products to a suitable point exiting the building.

The following chart is supplied to assist the contractor for specific parameters of each GasTrac model. *Refer to the GasTrac's operation manual for additional information.*

GasTrac Model	Combustion Air CFM {CMH}	Max. Flue Temp °F {°C}
CGT150	30 {0.8}	750 {399}
CGT250	50 {1.4}	750 {399}
CGT350	70 {1.9}	750 {399}
CGT500	100 {2.8}	750 {399}
CGT700	130 {3.7}	750 {399}

Installing the Conair GasTrac

(continued)

- 4 If an extremely long length of exhaust ducting is used, Conair recommends using condensation traps as necessary. For every 1,000 cubic feet {28.3 cubic meters} of gas burned, 6 gallons {22.7 L} of water vapor will be produced in the flue gases. If the flue gas temperature drops below 212°F {100°C}, the vapor in the flue will condense to water.

Connecting the Gas and the Exhaust Flue to the GasTrac

 **WARNING:** Conair strongly recommends that the steps below be completed by a qualified mechanical contractor in compliance with all applicable natural gas codes in your region.

1 Install the exhaust ducting and flue. Consult government codes and a qualified mechanical contractor for detailed installation instructions and assistance. **The customer-supplied flue must be insulated.** See *Description section entitled, Specifications: GasTrac (CGT) Process Air Heater for operating characteristics and general recommendations.*

2 Connect the flue to the GasTrac's exhaust outlet. Attach the "T" pipe to the GasTrac's exhaust outlet using the provided "V" clamp. Connect the "T" pipe to the exhaust flue.

 **WARNING:** Do not operate the GasTrac without a properly installed exhaust flue. You must install an exhaust flue to vent the combustion gases produced by the GasTrac. The installation should comply with government codes in your area and be done by a qualified mechanical contractor familiar with industrial flue and ducting systems.

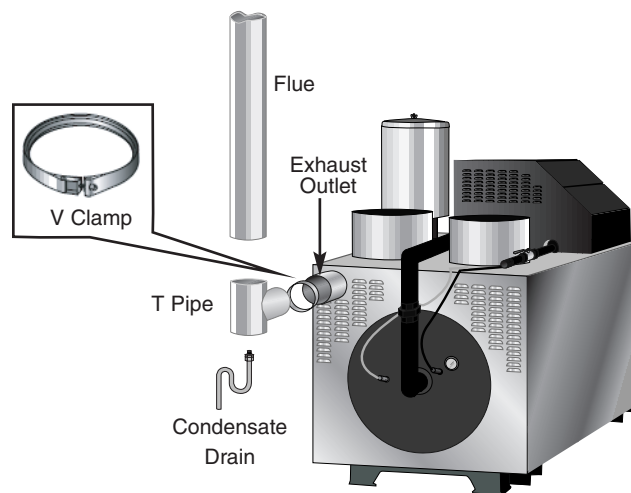

 **TIP:** A condensate trap and drain can be made by bending a piece of stainless steel tubing. Secure the drain to the "T" pipe using the appropriate compression fitting.



3 Insulate the flue and exhaust "T" assembly. Exhaust flue and "T" temperatures can reach up to 750°F {399°C}.

4 Install a condensate trap and drain. Condensate occurs when flue gases cool below their dew point. This condensate can be highly corrosive. Draining and disposal should be done in compliance with applicable safety and environmental codes in your area.

Connecting the Gas and the Exhaust Flue to the GasTrac

(continued)

- 5** Connect the gas supply line to the inlet on the GasTrac fuel train. Check to ensure that a water trap and inline basket filter has been installed on the supply line.

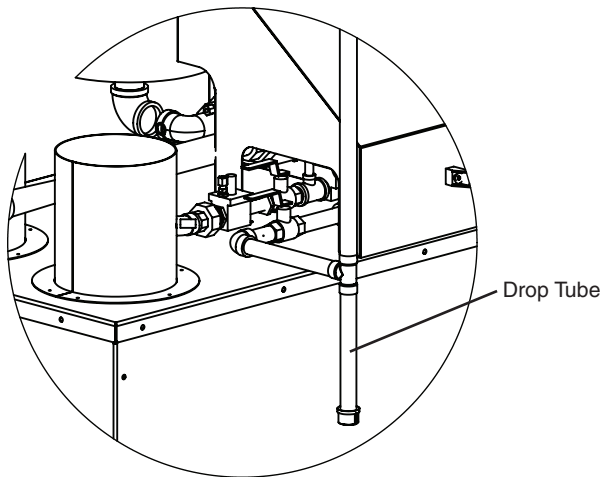

- 6** Check all gas lines for leaks. Use a gas detecting device or apply soapy water around pipe and fittings, check for bubbles.
- 7** Purge the gas lines after the pipe and fittings are free of leaks. The lines must be free of air, rust, scale, pipe dope and welding slag.

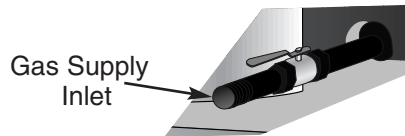

Gas Inlet Fitting Sizes

Model	NPT size
CGT150	3/4 in.
CGT250	3/4 in.
CGT350	3/4 in.
CGT500	3/4 in.
CGT700	1 in.

 **NOTE:** Conair strongly recommends that a “drop tube” be utilized when piping the gas line into the GasTrac. This will help to prevent any oil or metal shavings, created during the installation process, from entering the GasTrac.

Installation - Testing

Checking for Proper Air Flow

⚠ IMPORTANT: This procedure must be performed before loading material into the hopper.

⚠ CAUTION: If the air flow direction is incorrect due to improper phase connection, material from the hopper can be pulled back into the dryer, causing permanent damage to this equipment.

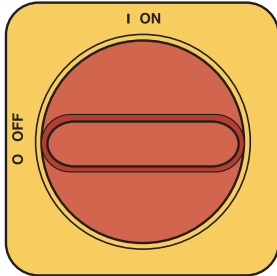

Opening and Closing the Dryer Doors (W1600 - 5000)

To unlock the side panel door bolts:

1 Rotate the two (2) locking door bolts on the dryer door counterclockwise with a regular screw driver.

2 Close the dryer doors and rotate the two (2) locking door bolts clockwise to resecure the dryer doors.

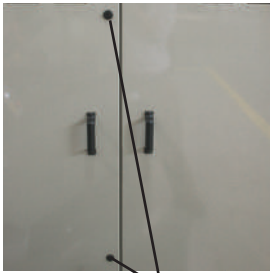

Dryer Door Locking Bolts (2) (W1600-5000)



Testing for Proper Rotation

1 Turn on the main power to the dryer. Make sure the dryer's disconnect dial is in the ON position. This powers up the control and the display will illuminate.



Checking for Proper Air Flow (continued)

- From the Login Screen (Screen 1), press the “Dehumid Drying” button.
- Open the dryer’s side panel doors. If your dryer has locking door bolts, *see Installation section entitled, Checking the Dryer for Proper Air Flow, Opening the Dryer Doors.*

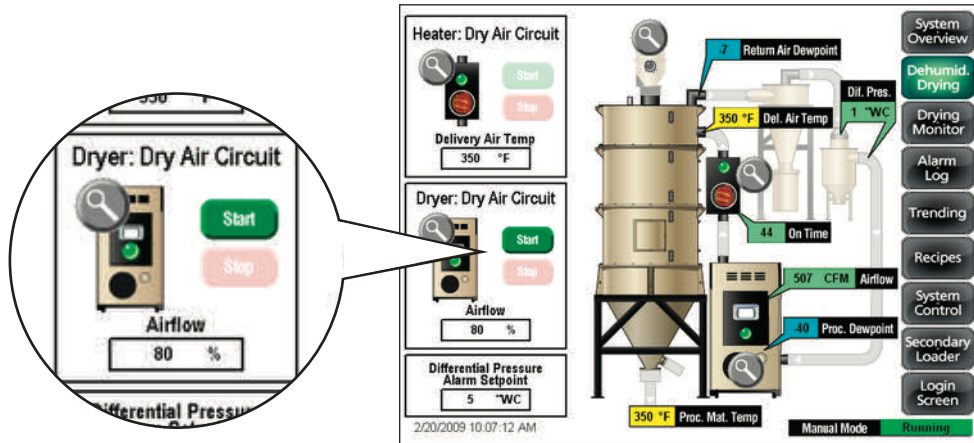

- Press the “Start” button and then the “Stop” button located within the Dryer: Dry Air Circuit window of the Dehumidifying Drying Screen (Screen 6).
- Visually verify the blower motor is moving in the correct direction indicated by the arrow on the blower housing. The EnergySmart W series 600-5000 dryers are equipped with centrifugal process blowers. Remember to also check the regen blower on ES1.



WARNING: All wiring, disconnects, and fuses should be installed by qualified electrical technicians in accordance with electrical codes in your region. Always maintain a safe ground. Do not operate the equipment at power levels other than what is specified on the machine serial tag and data plate.

Checking for Proper Air Flow (continued)

- 6** If air flow is incorrect disconnect power, follow proper lockout procedures and swap any 2 of the 3 incoming main power wires.

 **WARNING:** All wiring, disconnects and fuses should be installed by qualified electrical technicians in accordance with electrical codes in your region. Always maintain a safe ground. Do not operate the equipment at power levels other than what is specified on the the machine serial tag and data plate.

 If the air flow is reversed, the regeneration blower is turning in the wrong direction. Turn off and lock out the main power source. Open the electrical enclosure and reverse any two leads connecting the main power supply to the dryer.

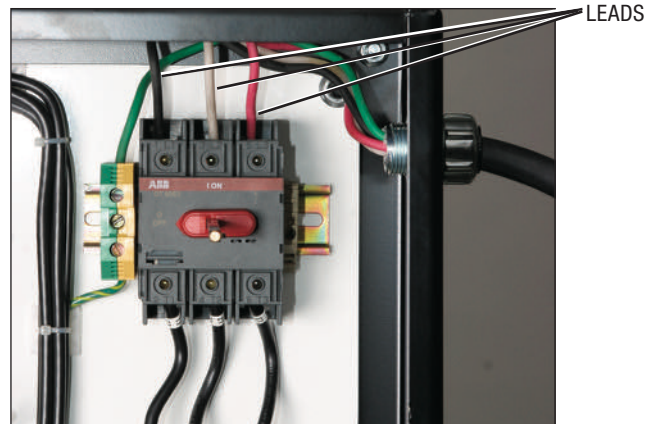
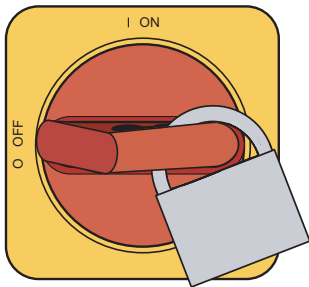

 **WARNING:** All wiring, disconnects and fuses should be installed by qualified electrical technicians in accordance with electrical codes in your region. Always maintain a safe ground. Do not operate the equipment at power levels other than what is specified on the machine serial tag and data plate.

Testing the Variable Frequency Drive (VFD)

- 1 Press the “Local/Remote” button** to switch the blower VFD on the back of the EnergySmart Dryer from the default of “Remote” to “Local”.
- 2 Using the “Start” and “Stop” buttons on the VFD, ‘Jog’ the motor to check for proper wheel rotation.** The motor should be started in accordance with the manufacturer's recommendations. Arrows on the process blower indicate the proper direction of rotation and air flow.

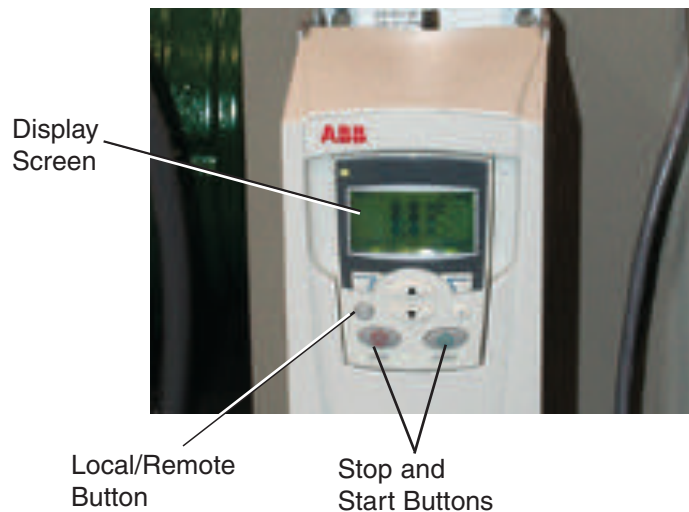

• TIP: The display screen shows the rotation direction. Rotation arrow should always be pointing forward (clockwise).

- 3 Press the “Start” button to bring the process blower up to speed.** Watch for anything unusual such as vibration, overheating of bearings and motor, etc.
- 4 Check the blower’s motor amperage against the nameplate amperage** to ensure that the motor is not overloading. The amperage is shown on the display screen.
- 5 Press the “Stop” button,** once the blower has been tested and is operating properly,
- 6 Switch the blower VFD from “Local” back to the default of “Remote”.**

Testing the Installation of the HTC



IMPORTANT: The EnergySmart Dryer must be running to perform this test.

- 1 Make sure there is no material in the CH Hopper.** If there is an optional receiver mounted on the hopper, disconnect the material inlet hose at the source.
- 2 Turn off the main power to the HTC.** Check to ensure that the disconnect dial is in the OFF position.
- 3 Perform a resistance test.** Check the resistance leg to leg and leg to ground to make sure that each heater and blower are wired correctly. The three legs should have equal resistance +/- 5%. The resistance to ground should be 20 megohms or higher. *See the Hopper Temperature Controller (HTC) manual for this procedure.*
- 4 Perform the following safety checks:**
 - Make sure all components are securely mounted
 - Make sure all hoses are connected to the proper locations and secured with hose clamps
 - Make sure all sensors are properly installed and secured
 - Make sure all wiring is secure and away from potential mechanical damage
 - Make sure the hopper outlet is free from obstructions that would cause back pressure in the drying hopper.
- 5 Start the EnergySmart Dryer,** *see Installation section entitled, Checking for Proper Air Flow.* Monitor the dryer during the first few minutes of operation to verify that the start-up operating sequences are correct.
- 6 Turn on the main power to the HTC.** Check to ensure that the disconnect dial is in the ON position. This powers up the control and the display lights will illuminate.

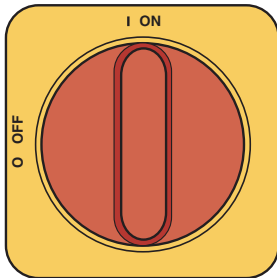



Testing the Installation of the HTC

(continued)

7 Adjust the HTC's setpoint to the required hopper inlet temperature. Use the setpoint Adjust ▲ or ▼ buttons to set the temperature. Move the heater enable switch to the "Enable" position. The temperature will begin rising to the user-entered setpoint.

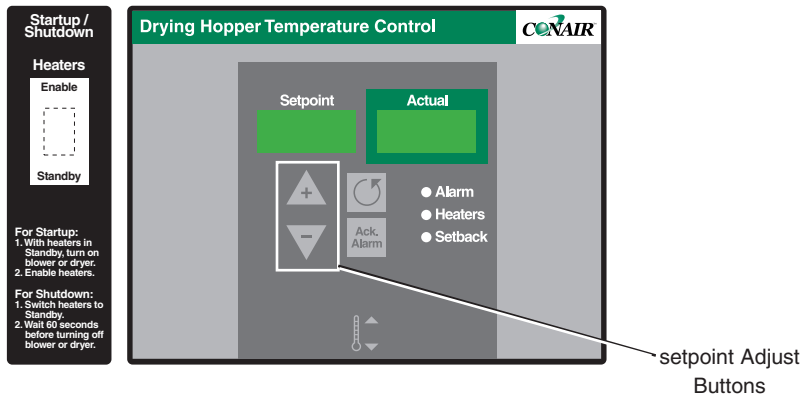
 **IMPORTANT:** The EnergySmart Dryer must be running to perform this test.



 **NOTE:** When testing the HTC, process protection should be enabled in the HTC's Control menu. This is especially important if the insulated heater outlet hose is extended or rerouted for any reason.

8 The "Heater" LED will flash and the temperature climbs towards the setpoint, if everything is operating properly.

 **NOTE:** Adjusting the HTC setpoint and running this test can be completed at the dryer by using the Touchview screen, as long as the green rocker switch is in the "Enable" position.

9 After the test has been completed successfully, switch the heater enable switch to "Standby", then turn off the power to the HTC (allow HTC to cool) and properly shut down the dryer, *see Operation section entitled, Stopping the EnergySmart Dryer System.*

 **NOTE:** When connected to an ES-1 System, the HTC must operate in English units.

Checking the Gas and Electrical Systems of the GasTrac

! **WARNING:** All wiring, disconnects and fuses should be installed by qualified electrical technicians in accordance with electrical codes in your region. Always maintain a safe ground. Do not operate the equipment at power levels other than what is specified on the machine serial tag and data plate.

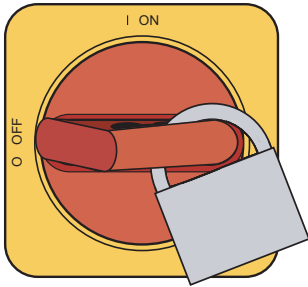

NOTE: When connected to an ES-1 System, the GasTrac must operate in English units.

1 Check all electrical connections.

- Shut off power to the unit and verify that the GasTrac and its burner controller is adequately grounded. Inadequate grounding can cause controller error messages and nuisance alarms.
- With power off to the GasTrac and the EnergySmart Dryer, verify that all terminal connections are tight and all new wiring is secured with an appropriately-sized strain relief.

2 Check gas piping and ducting.

- Verify that the gas delivery piping is rigidly supported.
- Verify that exhaust gas ducting is secured, adequately insulated, and free of leaks.

3 Check the GasTrac's fuel train for leaks. Turn on the gas supply to the GasTrac. Open the primary gas shutoff valve. Use a gas leak detection device or a squirt bottle of soapy water to detect leaks around gas pipe and fitting joints. Open the secondary gas shutoff valve and continue checking for leaks using the same procedure.

! **WARNING:** Ensure all gas lines are free of leaks. To prevent accident or injury, all gas lines, including the GasTrac's factory-mounted gas train, should be checked for leaks before firing the burner.

Testing the Installation of the GasTrac

- 1 Start the Energy Smart Dryer,** *see Operation Section, Starting the Dryer.*
Monitor the dryer during the first few minutes of operation to verify that the start-up operating sequences are correct.
- 2 Turn on the gas supply to the GasTrac.** All manual shut-off valves in the gas supply line and the GasTrac's fuel train must be in the open position. Before proceeding, use a detection device or soapy water to check for gas leaks in the GasTrac's fuel train.
- 3 Turn on main power to the GasTrac.** Turn the main disconnect dial to the ON position. If everything is installed correctly, the variable speed control's display will illuminate.
- 4 Press the Power switch to ON.**
 - The Power ON/OFF switch illuminates.
 - The temperature controller begins a 3-second self-test. The display will flash between STANDBY and the setpoint temperature.
 - The Burner Controller begins a 10-second initiation, which ends when the display indicates STANDBY.

 **IMPORTANT:** The EnergySmart Dryer must be running to perform this test.

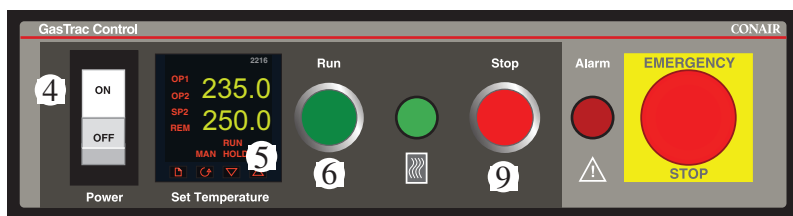
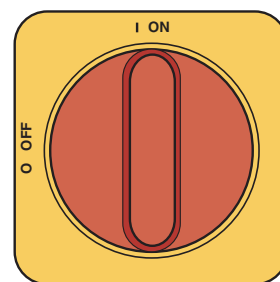

- 5 Set the drying temperature.** Press the up or down arrow on the temperature controller until 250°F appears in the lower display.
- 6 Press the “RUN” button.**
 - The green RUN light will illuminate after the Burner Controller finishes initializing.
 - The combustion blower will start and run for 90 seconds to purge any residual gas from the burner. (Check blower rotation at this time - See Step 7).
 - After the 90-second purge, the burner will ignite on low fire (low blower speed) for about 15 seconds. The burner will then go to high fire and gradually settle at a lower setting to maintain the setpoint temperature.

 **NOTE: BURNER START UP**
If the burner fails to ignite and the red alarm light illuminates, there may still be air in the gas lines. Check the burner controller display. If the alarm LED is illuminated, press the “Reset” button on the front of the electrical enclosure. If not, refer to the Troubleshooting section of the GasTrac User Guide and the burner controller manual.

(continued)

Testing the Installation of the GasTrac (continued)



IMPORTANT: Always refer to the wiring diagrams that came with your GasTrac before making electrical connections.



IMPORTANT: Always refer to the wiring diagrams that came with your GasTrac before making electrical connections.

- 7** **Verify the combustion blower is rotating in the correct direction.** The combustion blower uses a three-phase blower. Hold a strip of paper or piece of string near the blower inlet filter. If the paper or string blows away from the filter, the blower is rotating in the **wrong** direction. Stop the GasTrac. Disconnect and lockout the main power source. Reverse any two incoming electrical leads on the blower at the VFD output and repeat the test procedure.



Combustion
Blower Inlet
Filter

- 8** Allow the actual temperature to reach setpoint.
- 9** Once the setpoint is reached, press the “STOP” button.
- The green RUN indicator light turns off.
 - The gas inlet valves should close.
 - The combustion blower should stop.
 - The burner and temperature controllers should display STANDBY.
- 10** After the test has been completed successfully, **turn off the power to the GasTrac, allow to cool, and properly shut down the dryer, *see Operation section entitled, Stopping the EnergySmart Dryer System.***

Testing the Primary Receiver (optional)

- 1 Make sure there is no material in the Primary hopper.
- 2 Disconnect the material supply hose of the optional receiver at the source.
- 3 Login to the EnergySmart Dryer control under the appropriate user name and password. See *Operation section entitled, Control Function Descriptions, Screen 1A-Login Screen.*
- 4 Navigate to the System Overview Screen (Screen 6).

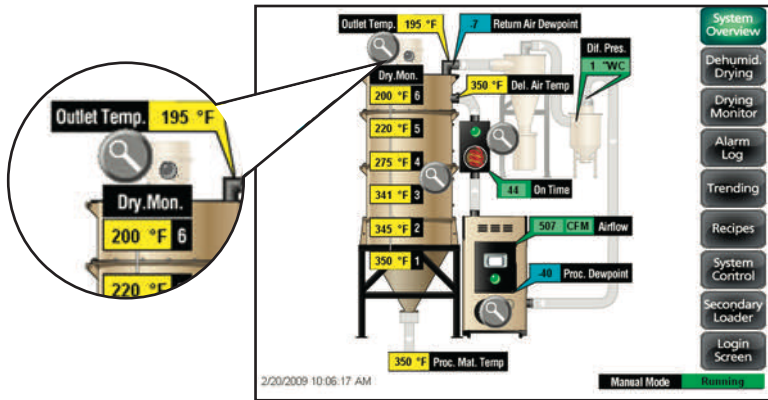

- 5 Press the receiver’s magnifying glass icon to access the Primary Loader Screen (Screen 5).

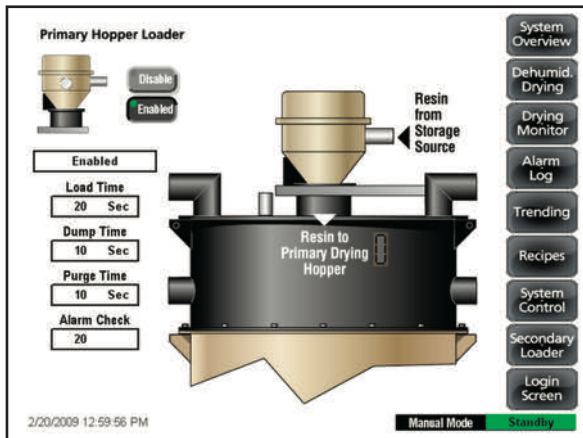

Testing the Primary Receiver (optional)

(continued)

6 Press the “Enable” button on the Primary Hopper Loader Screen (Screen 5) to activate the primary receiver.

If everything is installed correctly:

- The Positive Displacement Pump will turn on for the duration of the load time set at this screen.
- The purge valve will purge the conveying line leaving the CH Hopper
- The discharge valve of the receiver will open at the end of the load cycle time for the duration of the dump time set at this screen.

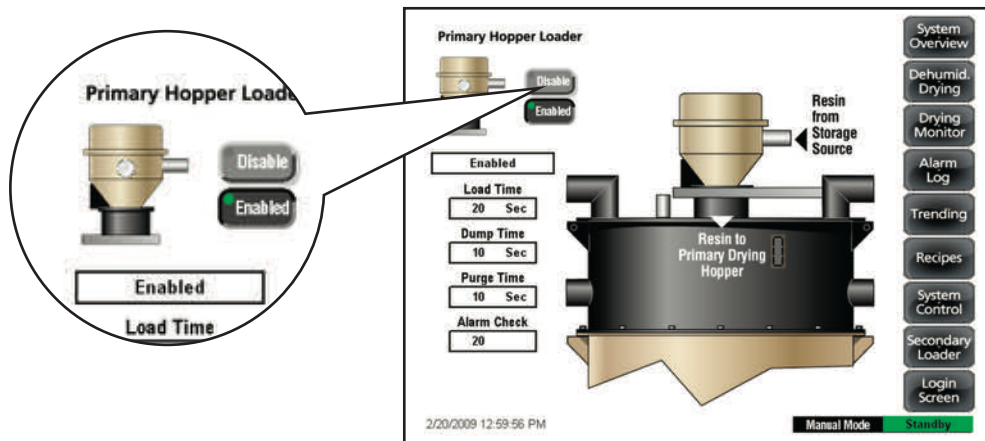

7 Press the “Disable” button on the Primary Hopper Loader Screen (Screen 5) to deactivate the primary receiver.

If everything is installed correctly, the following sequence should occur.

- The Positive Displacement Pump will turn off (unless idle mode equipped)
- The discharge valve of the receiver will close
- The purge valve will deactivate (if supplied)

8 After the test has been completed successfully, properly shut down the dryer; see *Operation section entitled, Stopping the EnergySmart Dryer System.*

Testing the Secondary Receiver

(optional)

- 1 Make sure there is no material in the secondary hopper.
- 2 Disconnect the material supply hose of the receiver at the source. (Bottom of primary hopper)
- 3 Login to the EnergySmart Dryer control under the appropriate user name and password. *See Operation section entitled, Control Function Descriptions, Screen 1A-Login Screen.*
- 4 Navigate to the System Overview Screen (Screen 6).

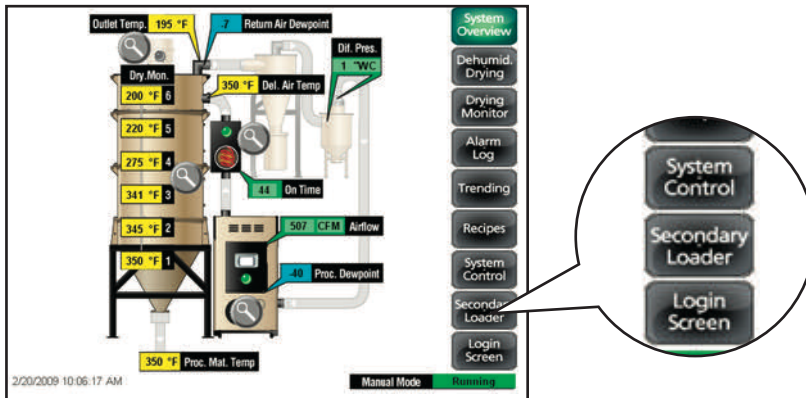

- 5 Press the “Secondary Loader” button to access the Secondary Loader Screen (Screen 18).

 **NOTE:** Secondary loader must have been enabled in setup.

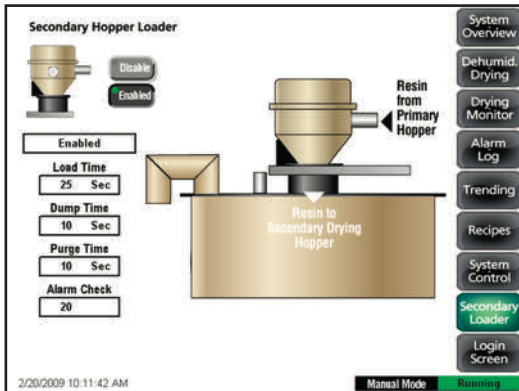

(continued)

Testing the Secondary Receiver

(optional) (continued)

- 6 Press the “Enable” button on the Secondary Hopper Loader Screen (Screen 18) to activate the secondary receiver.

If everything is installed correctly:

- The Positive Displacement Pump will turn on for the duration of the load time set at this screen.
- The purge valve will purge the conveying line (if supplied)
- The discharge valve of the receiver will open at the end of the load cycle time for the duration of the dump time set at this screen.

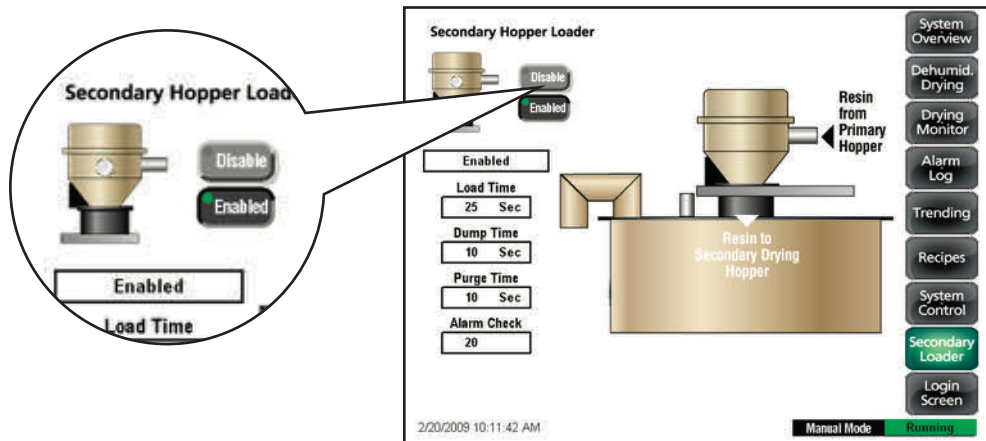

- 7 Press the “Disable” button on the Secondary Hopper Loader Screen (Screen 18) to deactivate the secondary receiver.

If everything is installed correctly the following sequence will occur:

- The Positive Displacement Pump will turn off (unless idle mode equipped)
 - The discharge valve of the receiver will close
 - The purge valve will deactivate (if supplied)
- 8 After the test has been completed successfully, **properly shut down the dryer**, *see Operation section entitled, Stopping the EnergySmart Dryer System.*

Configuring the Dwyer 641 Air Velocity Transmitter

The Dwyer 641 Air Velocity Transmitter must be programmed within the EnergySmart Dryer control for the correct dryer size before testing.

NOTE: For detailed programming information concerning the AVT probe, refer to AVT Appendix.

- 1 Start the EnergySmart Dryer.** Monitor the dryer during the first few minutes of operation to verify that the start-up operating sequences are correct.
- 2 Login to the EnergySmart Dryer control under the appropriate user name and password.** *See Operation section entitled, Control Function Descriptions, Screen 1A-Login Screen.*
- 3 Navigate to the Instrument Setup 2 Screen** (Screen 27).
- 4 Select the measuring range of the AVT by following the range selection instructions within the Dwyer Series 641 Air Velocity Transmitter Specifications - Installation and Operating Instructions** that are supplied with the EnergySmart Dryer System. The measuring range will change based on the blower size.

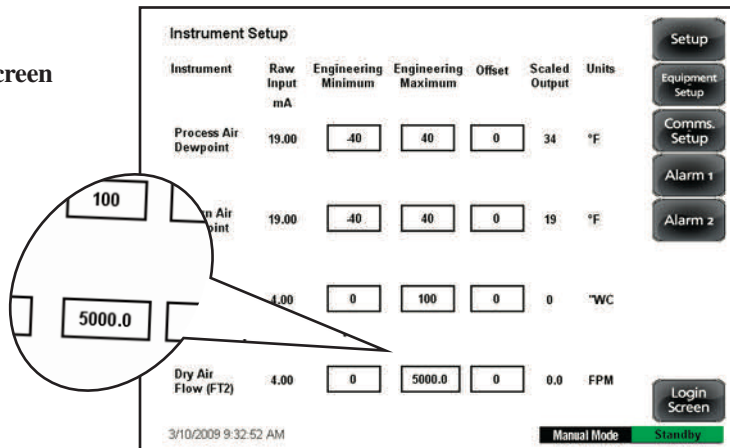

Dryer Size	Design CFM	8 in. Pipe FPM	12 in. Pipe FPM	Range Selection FPM
W600	300	889	397	2000
W800	400	1185	530	3000
W1000	500	1481	661	5000
W1600	800	2369	1057	5000
W2400	1200	3553	1585	10000
W3200	1600	4737	2114	10000
W5000	2500	7401	3302	15000

- 5 Set the range of the AVT into the Engineering Maximum input field for the appropriate flow transmitter.** *See Operation section entitled, Control Function Descriptions, Screen 27.*
- 6 Run the dryer or blower and observe the FPM on the Instrument Setup 2 screen** (Screen 27). If Raw Input mA exceeds 20 mA, increase the range setting of the AVT.

NOTE: Refer to Dwyer 641 Instructions found in the Appendix of this manual.

Configuring the DM-II Drying Monitor



NOTE: To understand the navigation of the DM-II control, see the Control flow diagrams contained in the supplied DM-II User's manual.

Setting Up the Drying Monitor-II (DM-II)



NOTE: Option must be enabled in Alarm Setup screen.

The EnergySmart Dryer control ships with the DM-II monitor software installed, however, all of the functions are turned off by default to avoid nuisance alarms created by improper setup.

To activate the DM-II monitor:

- Set the dryer process air temperature;
- Select an RTD for the alarm setpoint; and
- Select the low temperature RTD sensor. (See the instructions supplied with the DM-II monitor for more details).

Selecting the low temperature RTD sensor will automatically engage the DM-II. Once the low temperature RTD is selected, the control will alert the operator if the appropriate drying temperature is not reached within four (4) hours (default time).



NOTE: If a change is made to the HTC or GasTrac, the DM-II will need to be reset. For more information, refer to the supplied DM-II User's manual.

Configuring the Level (optional)

The optional level switch sensor monitors the amount of material inside the CH Hopper and indicates to an optional receiver that a load cycle is required. If the probe is not configured correctly, material level readings will be inaccurate.

Refer to the level switch's manual for calibration instructions.

Testing the Installation

You have completed the installation. Now it's time to check to ensure all components operate together correctly.

- 1 Be sure that there is no material in the CH Hopper.** If you have mounted an optional vacuum receiver on the hopper, disconnect the material inlet hose at the source.
- 2 Turn on the main power to the dryer and the HTC or GasTrac.** Be sure that the dryer's disconnect dial is in the ON position. This powers up the touch screen control. Check to make sure that the HTC "Enable" switch is on. (if applicable).

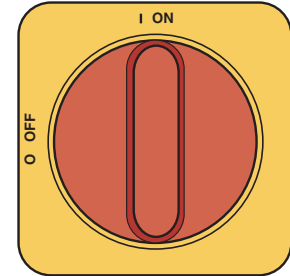

- 3 From the Login Screen (Screen 1), press the "System Control" button.**

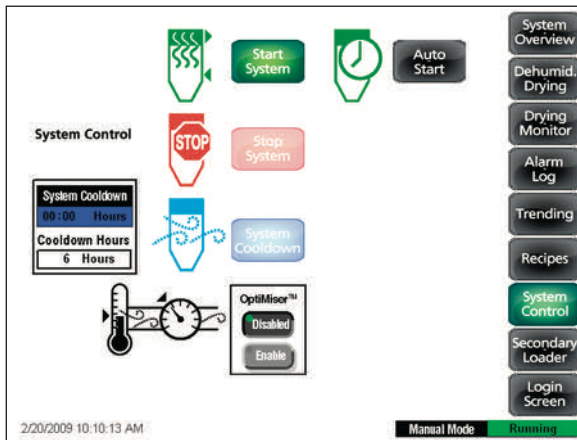

(continued)

Testing the Installation

4 From the System Control Screen (Screen 16), press the “Start System” button.

If everything is installed correctly:

- The regeneration and process blowers turn on. If process blower does not turn on, verify that the VFD is set to “Remote
- The regeneration heater turns on.
- The process heater will energize (HTC or GasTrac)
- The dryer’s desiccant wheel starts turning. If the desiccant wheel does not turn, verify that the desiccant wheel tie has been removed.
- The loader and pump will come on (if supplied, and if loaders enabled).

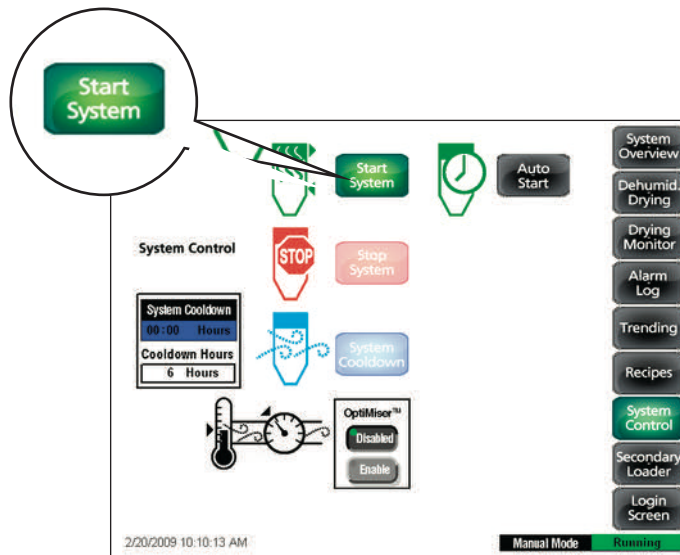

5 From the System Control Screen (Screen 16), press the “Stop System” button.

If everything is installed correctly:

- The blowers will process and continue running as needed to cool the heaters. (until regeneration heaters are less than 150°F{66°C})

6 The test is over. If the dryer performed the normal operating sequences as outlined, reconnect the material source to the optional hopper receiver and begin normal operation. If it did not, refer to the *Troubleshooting* section of the User Guide.

Operation

- The EnergySmart Dryer System
 - control panel 4-2
 - How to navigate the control screens. 4-3
 - Control function flow charts 4-6
 - Login flow chart 4-6
 - Operation flow chart 1 4-7
 - Operation flow chart 2 4-8
 - Operation flow chart 3 4-9
 - Setup flow chart 1 4-10
 - Equipment setup flow chart 1 4-11
 - Equipment setup flow chart 2 4-12
 - Communications setup flow chart 4-13
 - Example setpoint change. 4-14
 - Control function descriptions. 4-15
 - EnergySmart Dryer System security levels . . 4-54
 - EnergySmart Dryer System Modbus
 - communications. 4-56
 - Starting the EnergySmart Dryer System
 - (Without OptiMizer™ mode). 4-58
 - Adjusting the EnergySmart Dryer System
 - (Without OptiMizer™ mode). 4-62
 - Starting the EnergySmart Dryer System
 - (With OptiMizer™ mode). 4-67
 - Stopping the EnergySmart Dryer System . . . 4-71
 - Using dryer recipes 4-74
 - Copying files from the EnergySmart
 - Dryer System 4-80
 - Using dewpoint 4-84
 - Using OptiMizer™ 4-85

The EnergySmart Dryer System Control Panel

On power-up, the EnergySmart® Dryer control displays the initial system "Login" screen (Screen 1A).



At start-up, the system security level is "Default". Once the operator enters the user name and password, access is permitted to the "Login Setup" screen (Screen 1B). From this screen the user, depending on security access level, can access the various system and setup screens for the entire EnergySmart Dryer system.

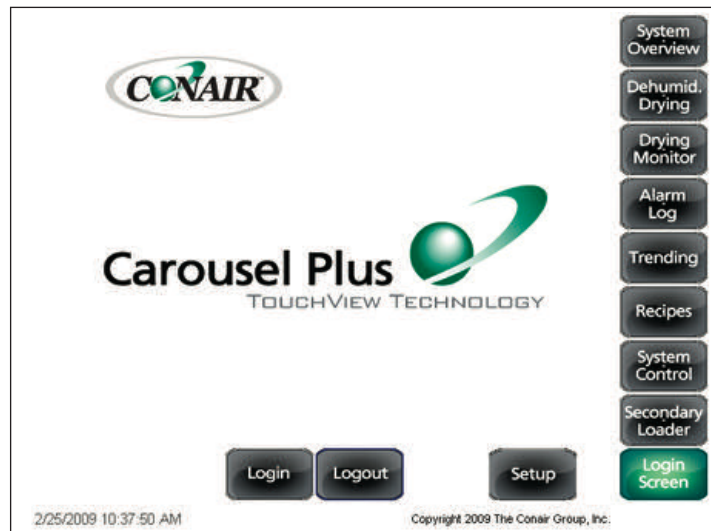

The following two sections provide flowcharts that detail the navigation between the EnergySmart Dryer Control screens and provide a description of the functionality of each screen.

How to Navigate the Control Screens

Navigate through the Energy Smart Dryer Control Screens by touching any navigation "buttons" and/or magnifying glass icons.

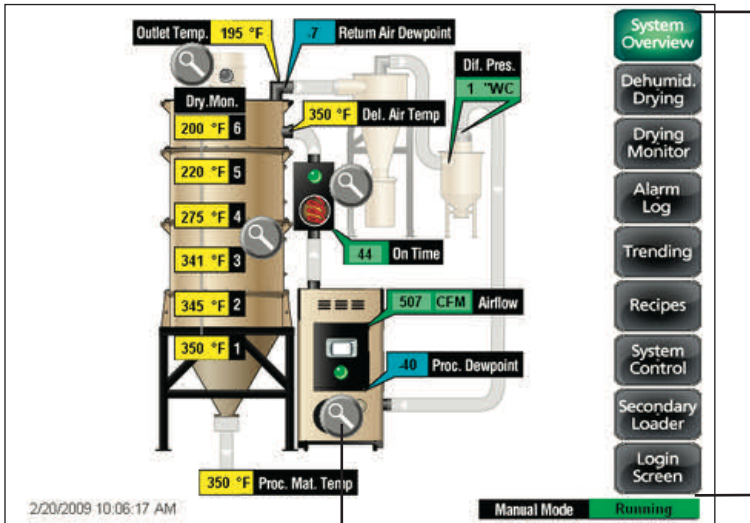

Navigation Buttons

Touching the navigation buttons will take the user to the control screen selected.

Magnifying Glass Icons

Touching the magnifying glass icons will take the user to screens that contain detailed information about the system component selected.

 **NOTE:** Some buttons may be grayed out indicating that an option is not installed, or the user does not have access to those functions.

(continued)

How to Navigate the Control Screens (continued)

The user name, password and other information can be entered using the pop-up keyboard window that appears when an appropriate field is touched.

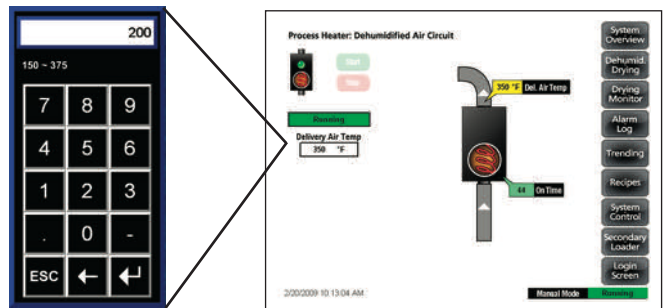
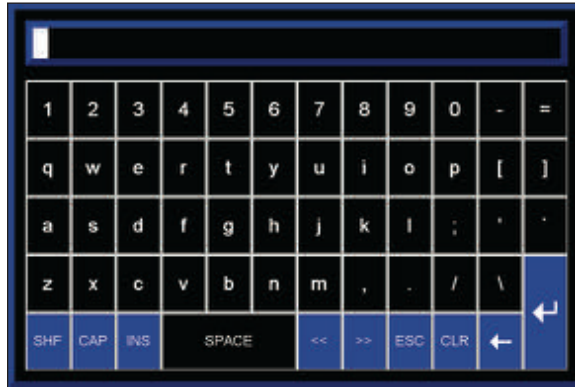

 **NOTE:** Password required for changing setpoints.

Set points can be entered within fields with a heavy black boundaries. Values shown within colored boxes are “actual” values and can not be changed.

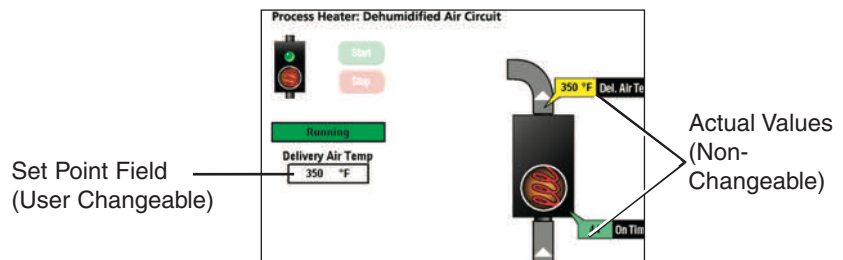

How to Navigate the Control Screens (continued)

When a system component is to be selected from a list of parameters, the "Up" and "Down" arrows can be used to highlight the selection. Press the "Enter" button to activate the selection.

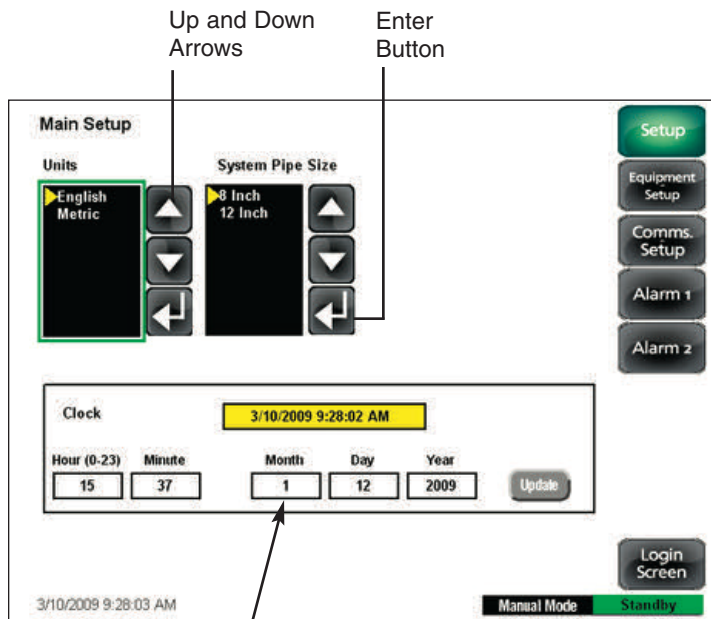



NOTE: The values shown in the data fields indicate the values entered when last updated.

Control Function Flow Charts

Login Flow Chart

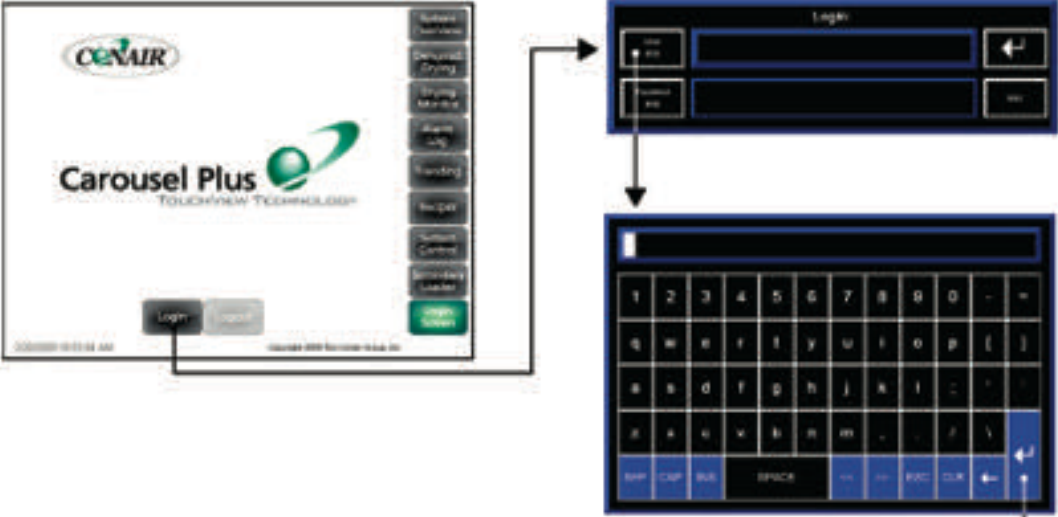
1A



 **NOTE:** Depending on your user login level, some functions may not be available.

1B



Control Function Flow Charts (continued)

Operation Flow Chart 1

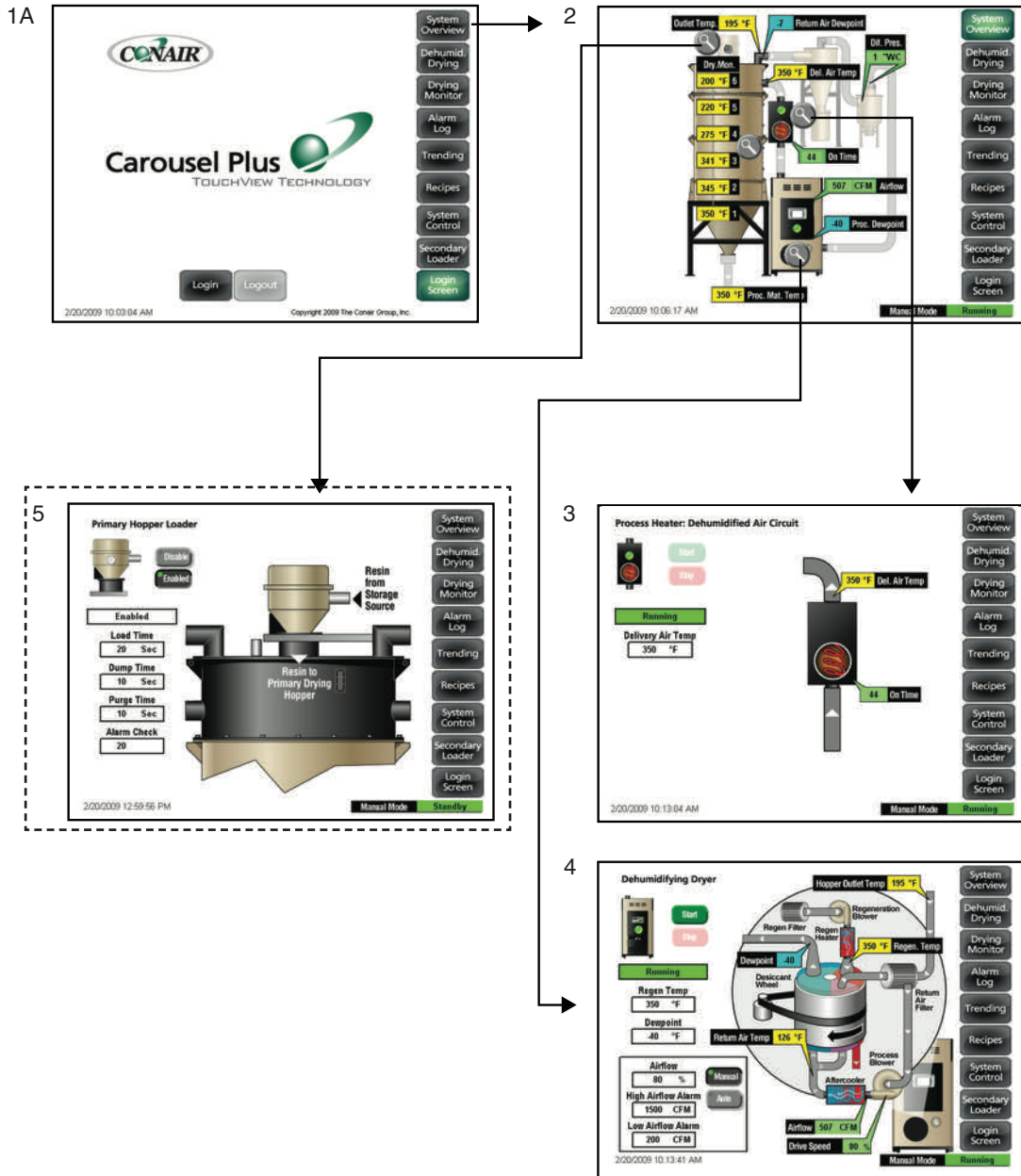

4
Operation

(continued)

Control Function Flow Charts (continued)

Operation Flow Chart 2

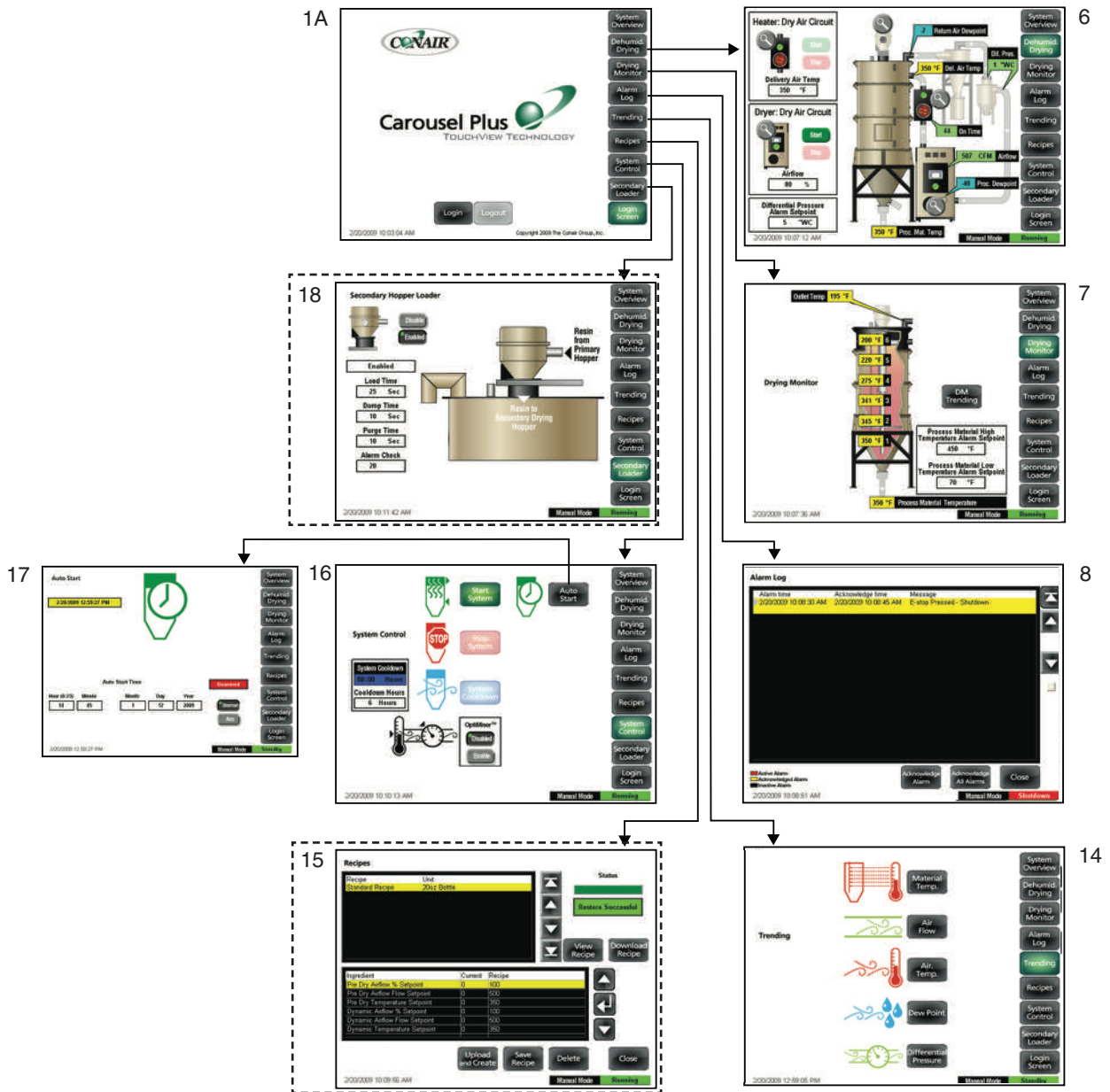

These screens are optional.

Control Function Flow Charts (continued)

Operation Flow Chart 3

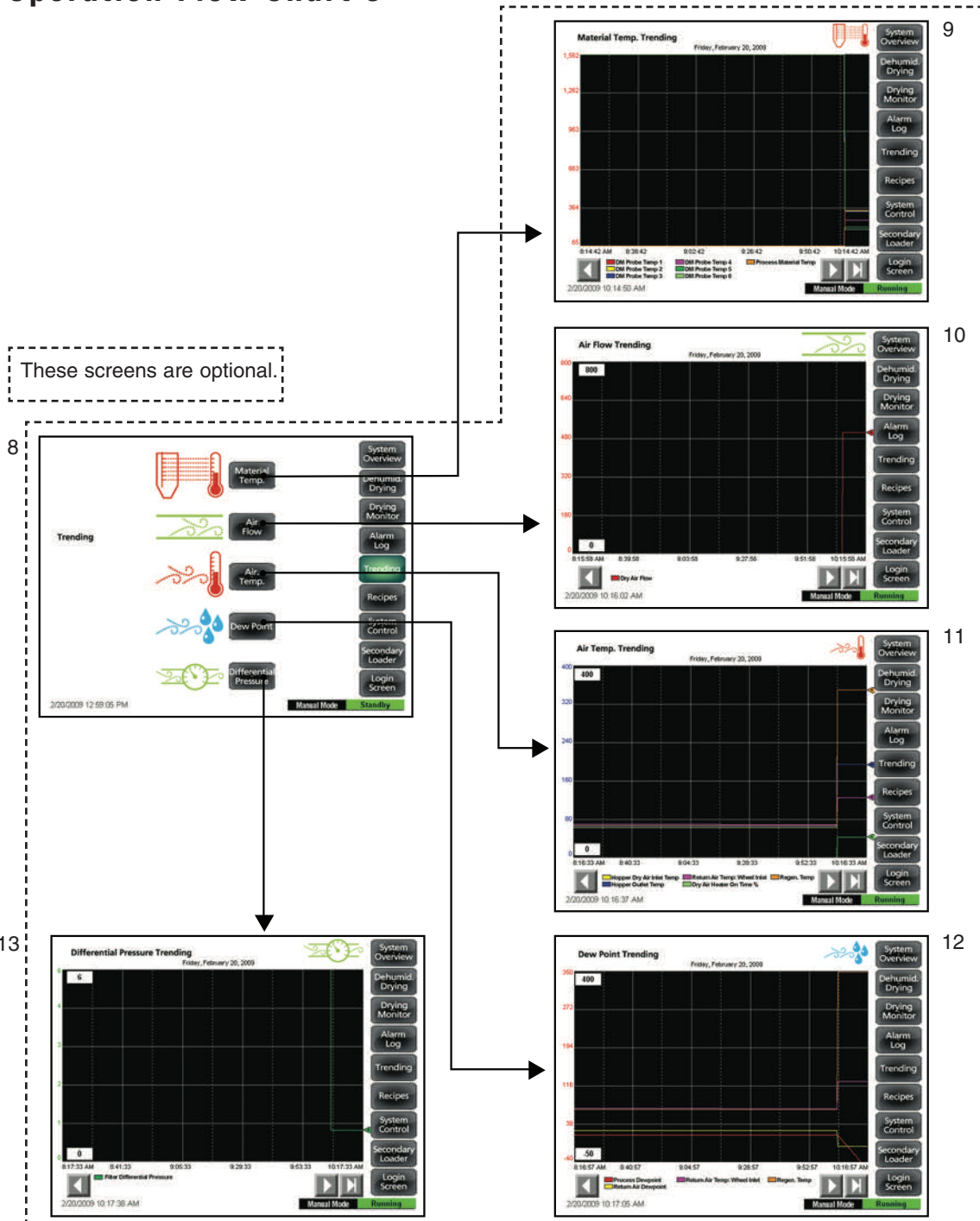

(continued)

Control Function Flow Charts (continued)

Setup Flow Chart 1

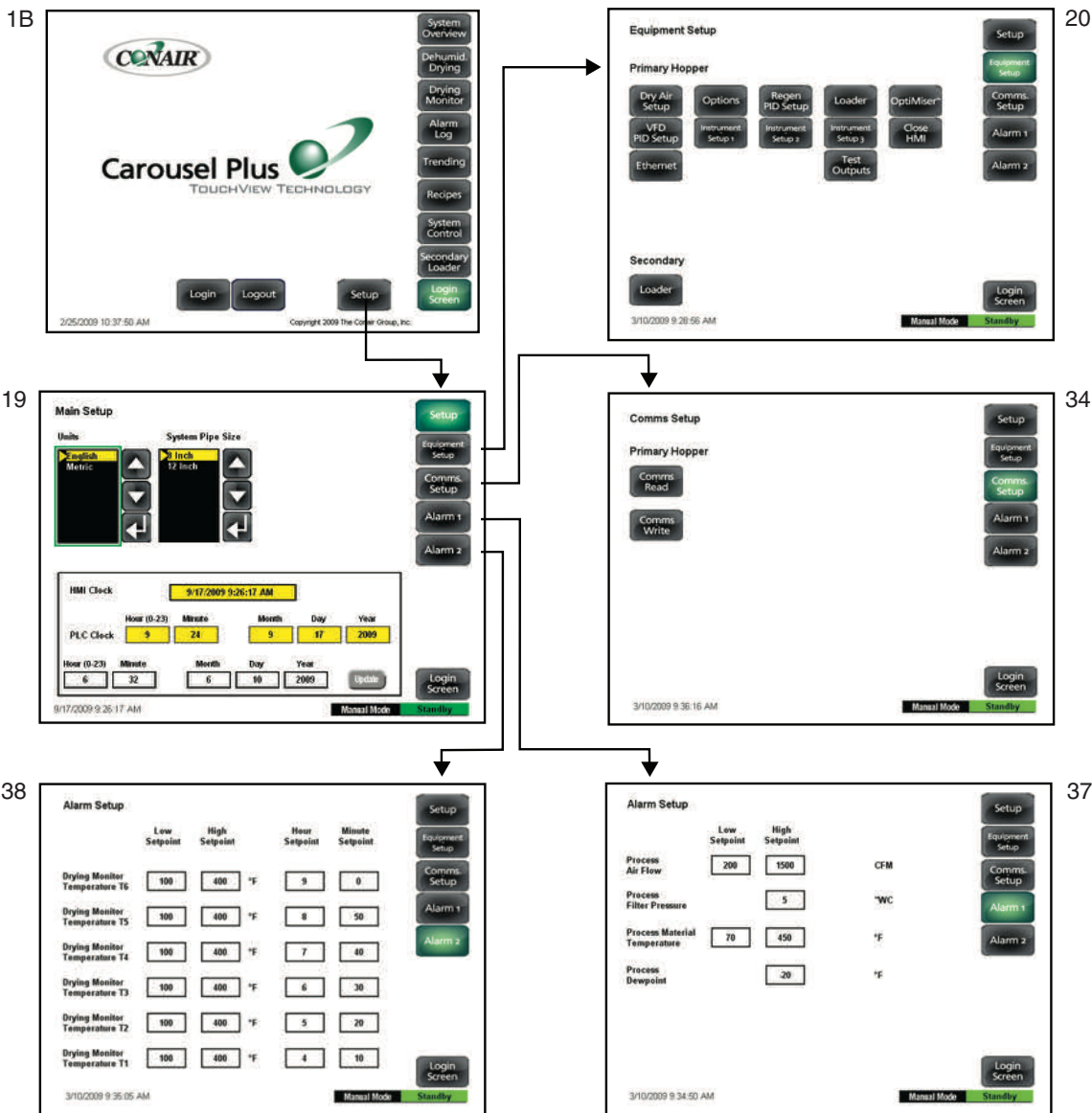

Control Function Flow Charts (continued)

Equipment Setup Flow Chart 1

These screens are optional.

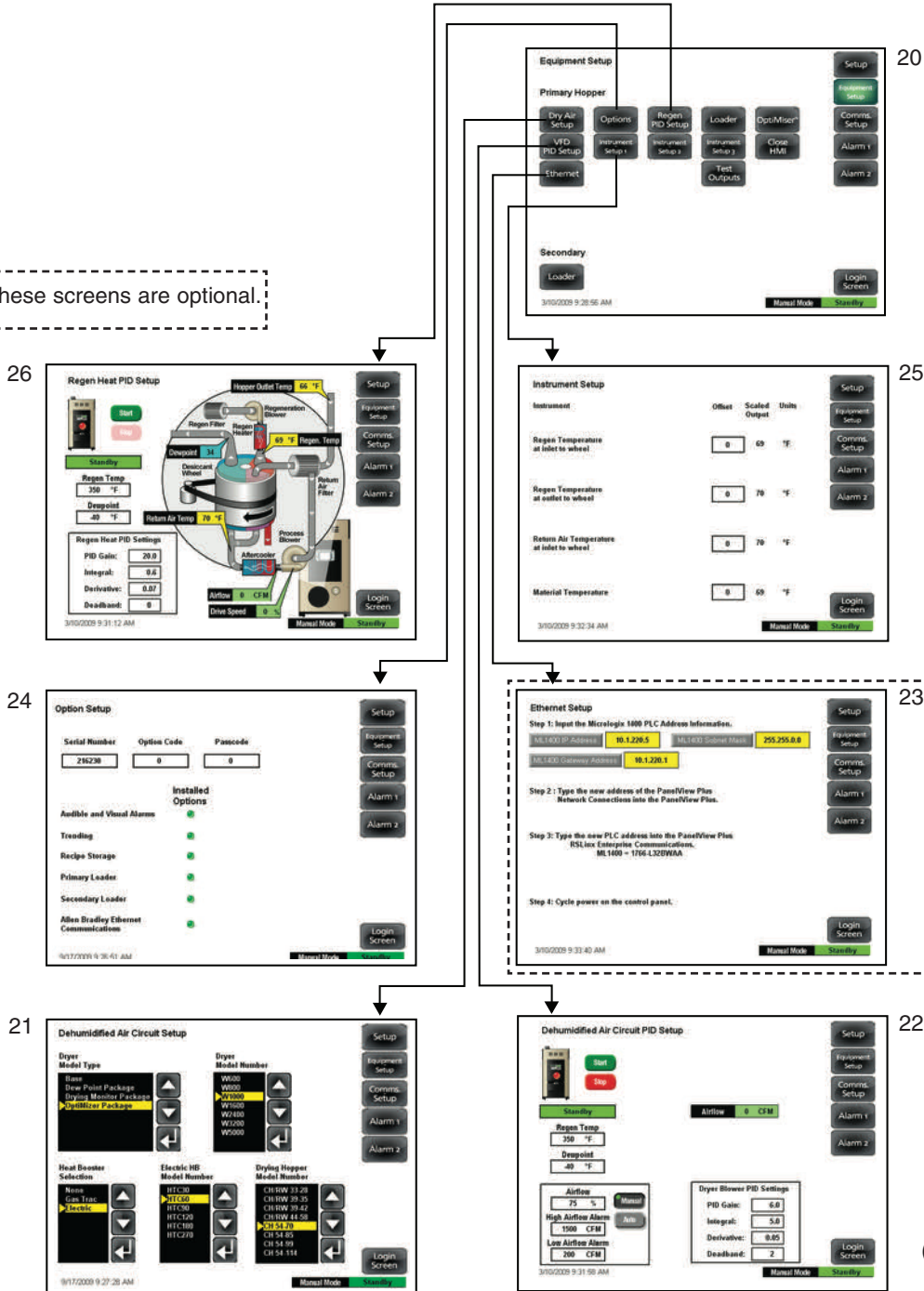

(continued)

Control Function Flow Charts (continued)

Equipment Setup Flow Chart 2

These screens are optional.

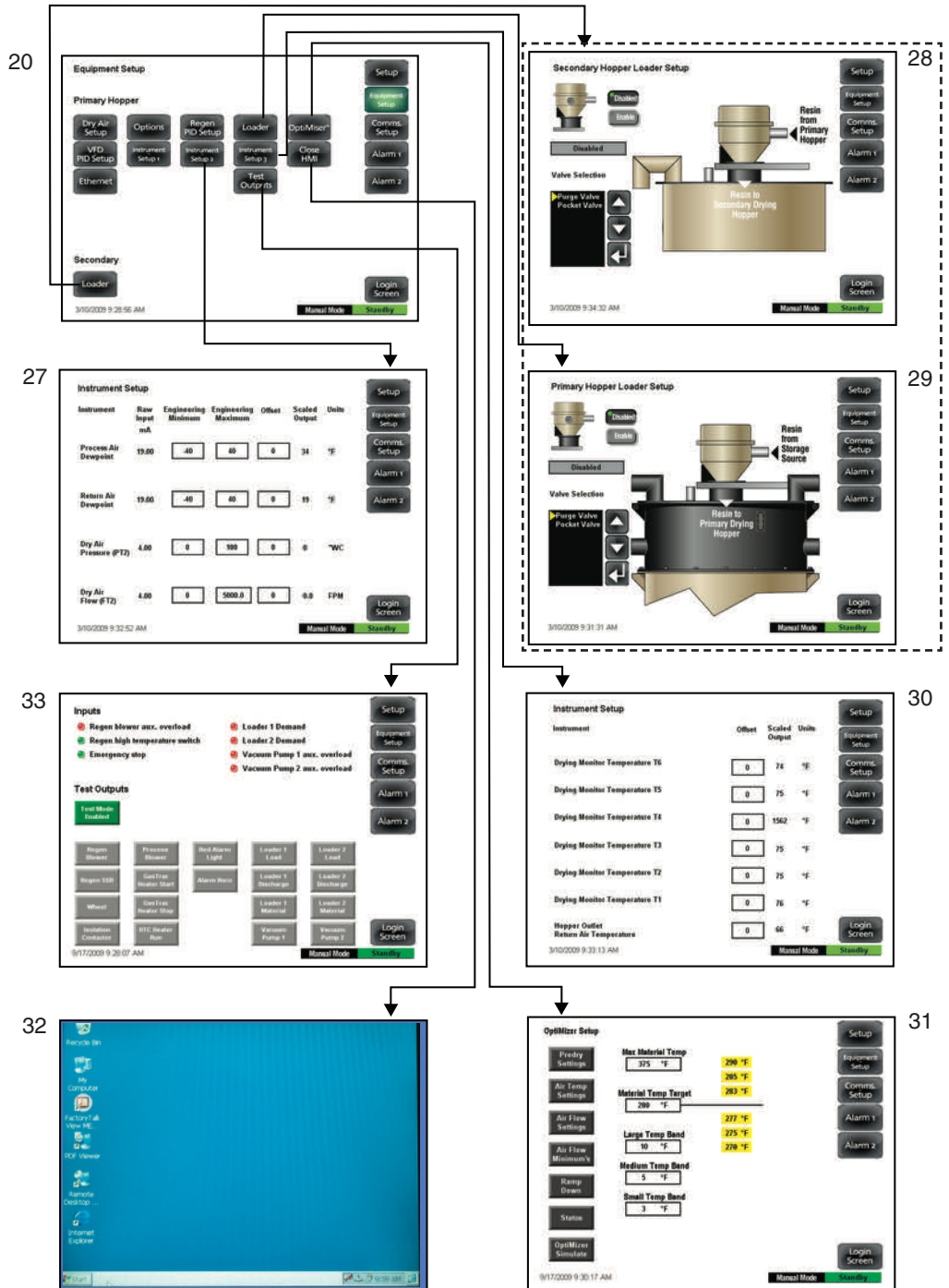

Control Function Flow Charts (continued)

Communications Setup Flow Chart

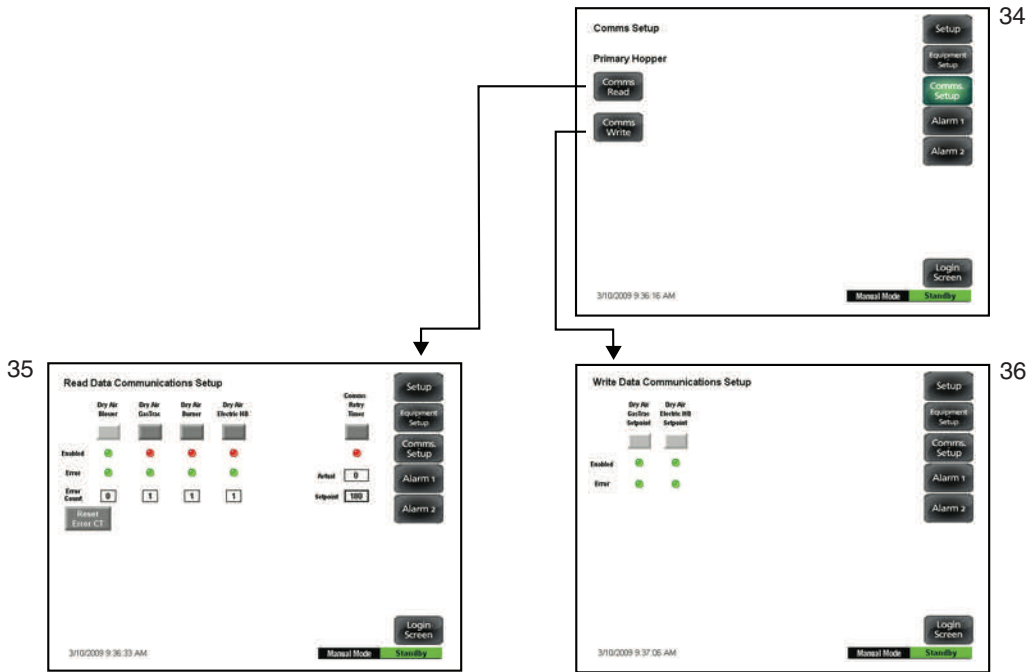



 **NOTE:** "Login" must be pressed to return to the System Overview in the setup screens.

(continued)

Control Function Flow Charts (continued)

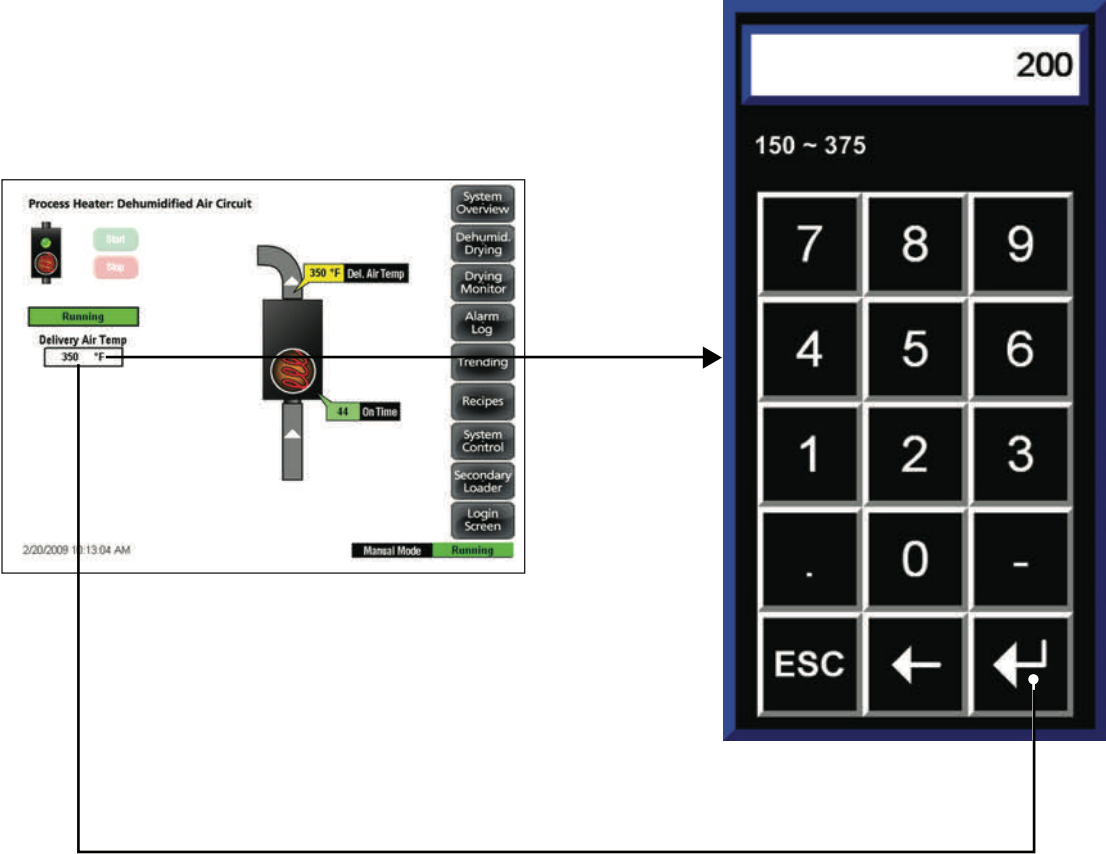
Example Set Point Change



 **NOTE:** Only white background boxes with numbers in them can be changed. Other color boxes are actual readings with no setpoint values.

Control Function Descriptions

Screen 1A - Login Screen



NOTE: From the "Login" screen, a user can navigate through all of the EnergySmart Dryer Control screens without logging onto the system. However, the user will not be able to change any setpoints until a correct password is used to login.

Upon start-up, the Login screen (Screen 1A) appears. This screen allows the user to login to the EnergySmart Dryer at the appropriate security level.

To login:

1 Press the "Login" button. This provides access to the "User/Password" window.

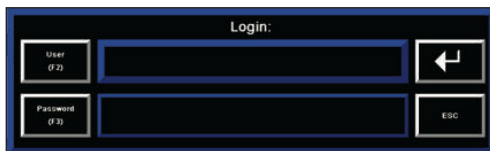

When either the "User" or "Password" buttons are pressed, a pop-up keyboard window appears that allows the user to enter their user name or password.

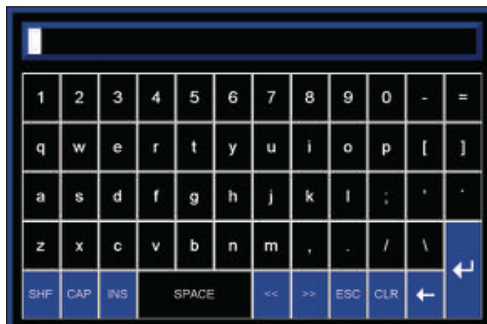

Control Function Descriptions (continued)

2 Press the "Enter" button to return to the "User/Password" window, after the user name or password has been entered.

3 Press the "Enter" button again to access the "Login Setup" screen (Screen 1B).

Screen 1B - Login Setup

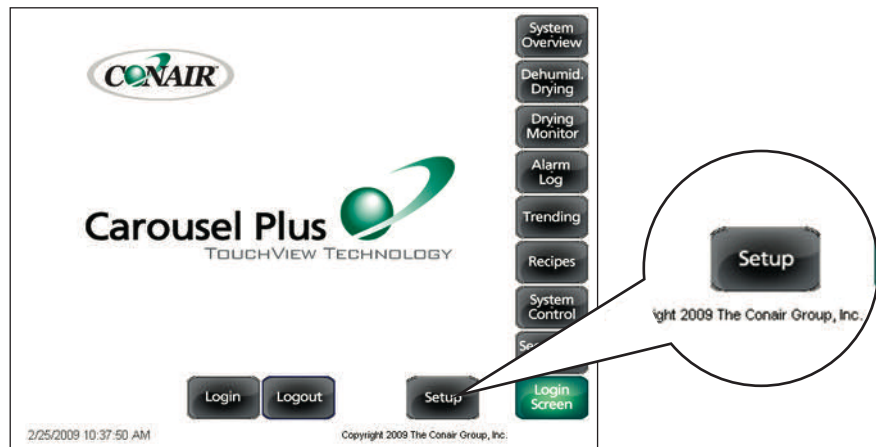

The Login Setup screen allows the user to access the system parameter screens by pressing the "Setup" button on the bottom, right side of the screen.

 **NOTE:** The "Setup" button is not available with "Operator" login.

Control Function Descriptions (continued)

Screen 2 - System Overview Screen

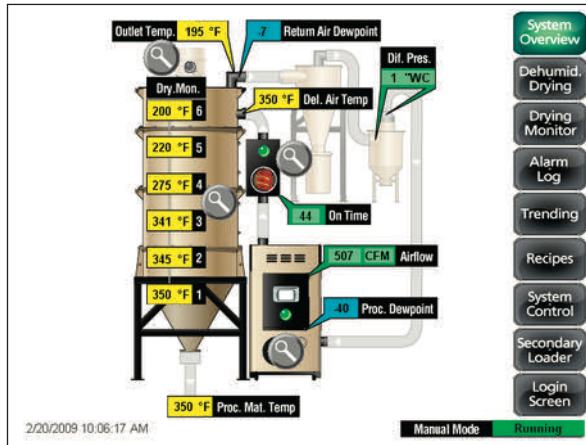

NOTE: When a "Magnifying Glass" icon appears on any screen within the EnergySmart Dryer control, touching the icon will take the user to screens that contain more specific information concerning that component. These screens also allow the user to turn system components on or off and to enter setpoints.

To access the System Overview Screen (Screen 2):

- 1 Press the "System Overview" button from the Login Screen, after logging-in to the EnergySmart Dryer Control.

The System Overview screen provides the user with the current information for all components within the EnergySmart Dryer including the hopper, the Dehumidifying Drying circuit (optional cyclone separator, optional dust collector, dryer, GasTrac or HTC heater). The information provided by this screen includes the temperature at various levels within the hopper as well as temperatures, dew points, differential pressures, and air flow rates of the air circulating within the system.

The user can also view the other system parameters, start the system, stop the system, initiate a system Cool Down or return to the "Login" screen by pressing the applicable buttons on the right of the screen.

Control Function Descriptions (continued)

Screen 3 - Process Heater: Dehumidified Air Circuit Screen

 **NOTE:** Screen 3 shows the type of heater installed in the Dehumidifying Drying Circuit of the EnergySmart Dryer System. If a GasTrac has been installed, the image on the screen will reflect a gas heater (flame). If an HTC has been installed, the image on the screen will reflect an electric heater (heating coil). The screen used in this example reflects an electric heater (heating coil).

 **NOTE:** Set points boxes are white with heavy black borders. Set points can be changed, if the user has logged in at the proper security level, pressing the set-point boxes will launch a pop-up keypad window that can be used to change the setpoint. [See Operation section entitled, Example Set Point Change.](#) After the new setpoint value has been entered, press the "Enter" key to lock in the new setpoint.

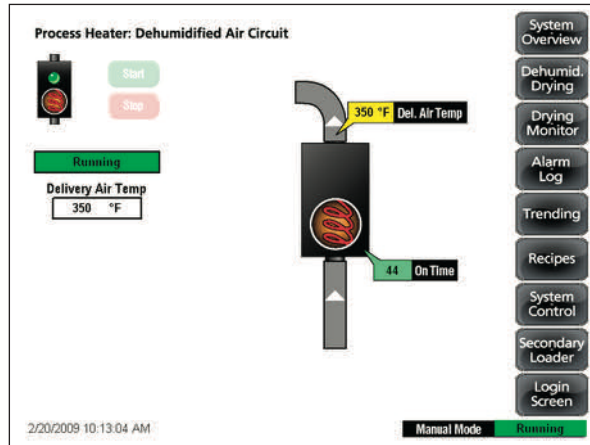

To access the Process Heater: Dehumidified Air Circuit Screen (Screen 3):

- 1 Press the Magnifying Glass icon button** associated with the heater in the dehumidifying drying circuit on Screens 2 or 6.

The Process Heater: Dehumidified Air Circuit screen provides the user with the current information concerning the on time %, the flame signal (gas heaters only), and the delivery air temperature. It also tells the user the current status of the heater (running or standby), the delivery air temperature setpoint, and allows the user to Start or Stop the secondary heater. If the user is logged-in at the proper security level, the delivery air temperature setpoint can be changed on this screen.

The user can also view the other system parameters, start the system, stop the system, initiate a system Cool Down or return to the "Login" screen by pressing the applicable buttons on the right of the screen.

Control Function Descriptions (continued)

Screen 4 - Dehumidifying Dryer Screen

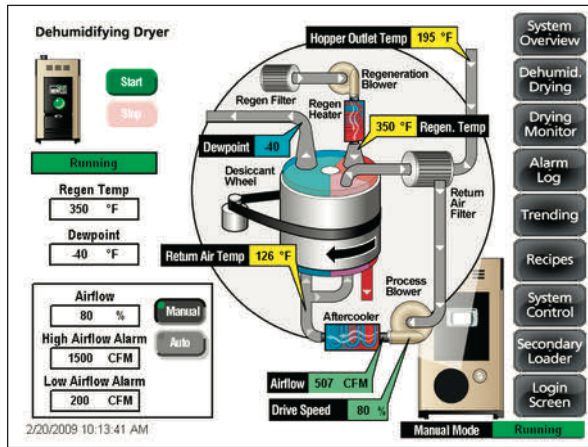

 **NOTE:** Set points boxes are white with heavy black borders. Set points can be changed, if the user has logged in at the proper security level, by pressing the setpoint boxes. This will launch a pop-up keypad window that can be used to change the setpoint. *See Operation section entitled, Example Set Point Change.* After the new setpoint value has been entered, press the "Enter" key to lock in the new setpoint.

To access the Dehumidifying Dryer Screen (Screen 4):

- 1 Press the **Magnifying Glass icon button** associated with the dryer in the dehumidifying drying circuit on Screens 2 or 6.

The Dehumidifying Dryer screen provides the user with the current information concerning the processes within the dehumidifying dryer including:

- Hopper Outlet Temperature (Temp)
- Regeneration Temperature (Regen. Temp) - should not need to be changed
- Dryer Blower Drive Speed (Drive Speed) - process blower
- Air flow Exiting the Dryer Blower (Air flow) - process airflow
- Return Air Temperature (Temp)
- Dew point - process dewpoint

It also tells the user the current status of the dryer blower (running or standby) as well as the setpoints for regeneration temperature, dew point, air flow, high air flow alarm, and the low air flow alarm setpoints. If the user is logged-in at the proper security level, the regeneration temperature, dew point, air flow, high air flow alarm, and the low air flow alarm setpoints can be changed on this screen.

This screen also allows the user to start or stop the dryer and select between auto or manual control for the dryer blower. The user can also view the other system parameters, start the system, stop the system, initiate a system Cool Down or return to the "Login" screen by pressing the applicable buttons on the right of the screen.

 **NOTE:** The air flow setpoint will be shown as "%" if the dryer airflow VFD is set to "Manual". The air flow setpoint will be shown as "CFM" if the dryer "VFD" is set to "Auto".

(continued)

Control Function Descriptions (continued)

Screen 5 - Primary Hopper Loader Screen (optional)

 **NOTE:** Set points boxes are white with heavy black borders. Set points can be changed, if the user has logged in at the proper security level, by pressing the setpoint boxes. This will launch a pop-up keypad window that can be used to change the setpoint. See [Operation section entitled, Example Set Point Change](#). After the new setpoint value has been entered, press the "Enter" key to lock in the new setpoint.

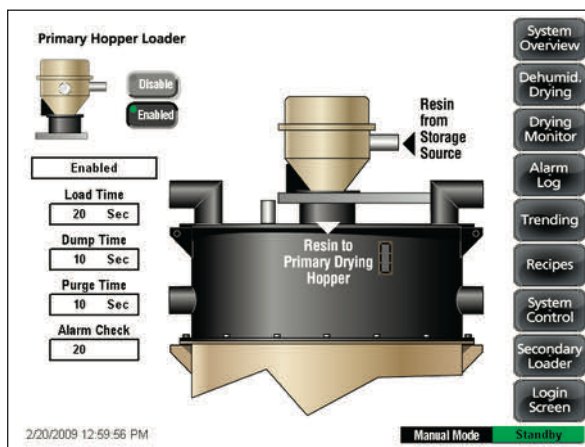

To access the Primary Hopper Loader Screen (Screen 5):

- 1 Press the Magnifying Glass icon button** associated with the optional receiver in the dehumidifying drying circuit on Screens 2 or 6.

The Primary Hopper Loader screen allows the user set the load time, dump time, purge time and alarm checks of the receiver. If the user is logged-in at the proper security level, these settings can be changed from this screen. See [specific receiver's manual for correct settings of these parameters](#). Once the correct times have been entered, press the "Enabled" button to activate the primary receiver. Pressing the "Disabled" button will de-activate the receiver. The receiver's current status will be displayed under the receiver's icon in the top left side of this screen.

The user can also view the other system parameters, start the system, stop the system, initiate a system Cool Down or return to the "Login" screen by pressing the applicable buttons on the right of the screen.

Control Function Descriptions (continued)

Screen 6 - Dehumidifying Drying Screen

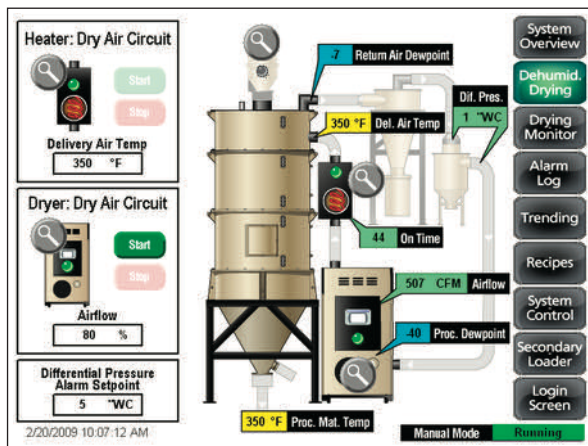

 **NOTE:** Set points boxes are white with heavy black borders. Set points can be changed, if the user has logged in at the proper security level, by pressing the setpoint boxes. This will launch a pop-up keypad window that can be used to change the setpoint. See [Operation section entitled, Example Set Point Change](#). After the new setpoint value has been entered, press the "Enter" key to lock in the new setpoint.

 **NOTE:** The air flow setpoint will be shown as "%" if the dryer airflow VFD is set to "Manual". The air flow setpoint will be shown as "CFM" if the dryer "VFD" is set to "Auto".

To access the Dehumidifying Drying Screen (Screen 6):

1 Press the "Dehumid. Drying" button located on the right side of the screen.

The "Dehumid. Drying" screen provides the user with the current information for the system components within the Dehumidifying Drying Circuit of the EnergySmart Dryer including the optional cyclone separator, optional dust collector, dryer, and GasTrac or HTC heater. The information provided on this screen includes the delivery air temperature at the hopper, the return air dew point, the differential pressure across the dust collector or process filter, the air flow rate in the dryer, the process dew point in the dryer, the "On" time at the heater and the process material temperature leaving the hopper.

The Dehumid. Drying screen also allows the user to start or stop the heater or dryer and lists the delivery air temperature, the air flow at the dryer, and the differential pressure alarm setpoints. If the user is logged-in at the proper security level, the delivery air temperature, air flow at the dryer, and differential pressure alarm setpoints can be changed from this screen.

The user can also view the other system parameters, start the system, stop the system, initiate a system Cool Down or return to the "Login" screen by pressing the applicable buttons on the right of the screen.

(continued)

Control Function Descriptions (continued)

Screen 7 - Drying Monitor Screen

 **NOTE:** Set points boxes are white with heavy black borders. Set points can be changed, if the user has logged in at the proper security level, by pressing the setpoint boxes. This will launch a pop-up keypad window that can be used to change the setpoint. See [Operation section entitled, Example Set Point Change](#). After the new setpoint value has been entered, press the "Enter" key to lock in the new setpoint.

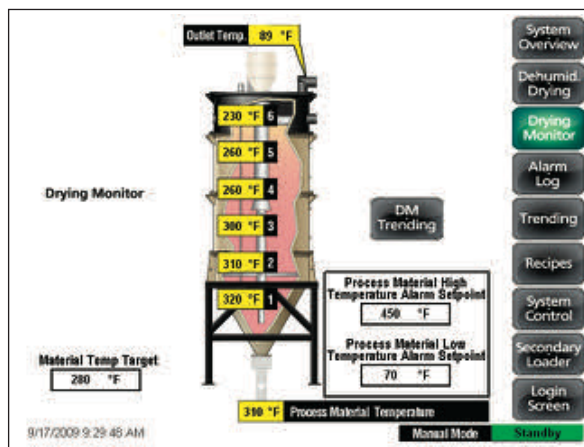

To access the Drying Monitor Screen (Screen 7):

1 Press the "Drying Monitor" button located on the right side of the screen.

The "Drying Monitor" screen provides the user with the current information for the system's hopper. The information provided on this screen includes the temperatures at various levels within the hopper, the outlet air temperature from the hopper and the process material temperature leaving the hopper.

The Drying Monitor screen also provides the user with the process material high and low temperature alarm setpoints. If the user is logged-in at the proper security level, the process material high and low temperature alarm setpoints can be changed on this screen.

The "DM Trending" button on this screen gives the user instant access to the Material Temperature Trending screen (Screen 9).

The user can also view the other system parameters, start the system, stop the system, initiate a system Cool Down or return to the "Login" screen by pressing the applicable buttons on the right of the screen.

Control Function Descriptions (continued)

Screen 8 - Trending Screen (optional)

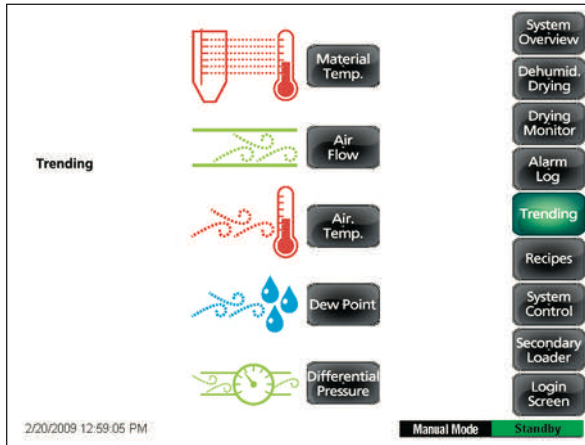

To access the Trending Screen (Screen 8):

1 Press the "Trending" button located on the right side of the screen.

The "Trending" screen allows the user to select a desired trending screen.

The choices are:

- Material Temperature (Temp.) (Screen 9)
- Air Flow (Screen 10)
- Air Temperature (Temp.) (Screen 11)
- Dew Point (Screen 12)
- Differential Pressure (Screen 13)

To select the specific type of trending screen, press the appropriate button on the Trending screen.

The user can also view the other system parameters, start the system, stop the system, initiate a system Cool Down or return to the "Login" screen by pressing the applicable buttons on the right of the screen.

Control Function Descriptions (continued)

Screen 9 - Material Temperature Trending Screen (optional)

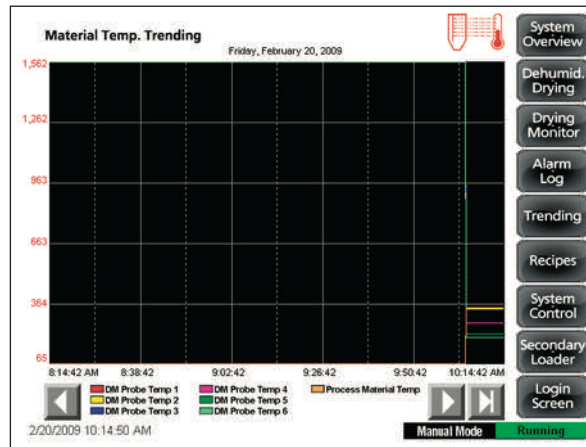

To access the Material Temperature Trending Screen (Screen 9):

- 1 Press the "Material Temp." button located on in the center of the Trending Screen (Screen 8).

The Material Temperature Trending screen allows the user to view the material temperature trend vs. time at seven (7) locations in the CH Hopper. The temperature reading locations are denoted by various colors and start at Location 6 (top of the hopper) and end with Location 1 (within the hopper cone) and Process Material Temp. (exiting the hopper). The colors associated with the locations are:

Orange	=	Process Material Temperature (Exiting the hopper)
Red	=	DM Probe Temp. 1 (hopper cone)
Yellow	=	DM Probe Temp. 2
Blue	=	DM Probe Temp. 3
Purple	=	DM Probe Temp. 4
Dark Green	=	DM Probe Temp. 5
Light Green	=	DM Probe Temp. 6 (Top of hopper).

The Material Temperature Trending screen shows a snap shot of the last two (2) hours of operation and records and saves trending data for the last 72-hour period. The scroll buttons near the bottom of the screen allow the user to scroll back to an earlier time or forward to the present time, plus jump to the present time from any time within the trending record.

The user can also view the other system parameters, start the system, stop the system, initiate a system Cool Down or return to the "Login" screen by pressing the applicable buttons on the right of the screen.

Control Function Descriptions (continued)

Screen 10 - Air Flow Trending Screen (optional)

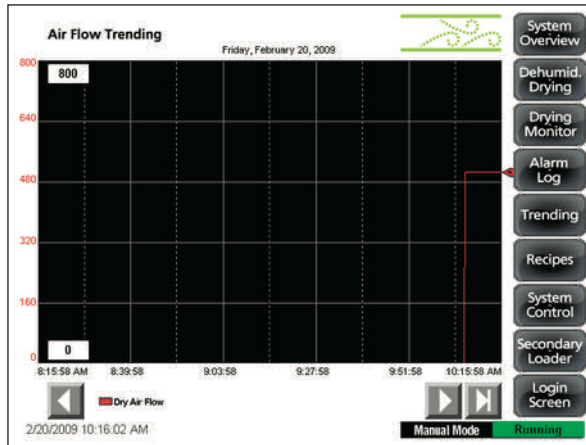

To access the Air Flow Trending Screen (Screen 10):

- 1 Press the "Air Flow" button located on in the center of the Trending Screen (Screen 8).

The Air Flow Trending screen allows the user to view the air flow (CFM) trend vs. time of the dehumidified drying circuit. The color red is associated with the dehumidifying drying circuit on this graph.

The Air Flow Trending screen shows a snap shot of the last two (2) hours of operation and records and saves trending data for the last 72-hour period. The scroll buttons near the bottom of the screen allow the user to scroll back to an earlier time or forward to the present time, plus jump to the present time from any time within the trending record.

The user can also view the other system parameters, start the system, stop the system, initiate a system Cool Down or return to the "Login" screen by pressing the applicable buttons on the right of the screen.

Control Function Descriptions (continued)

Screen 11 - Air Temperature Trending Screen (optional)

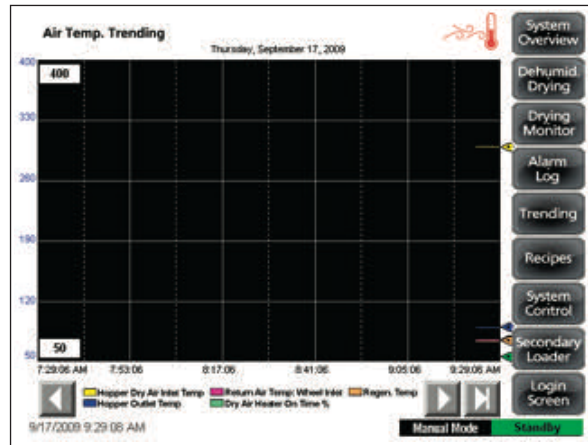

To access the Air Temperature Trending Screen (Screen 11):

- 1 Press the "Air Temp." button located in the center of the Trending Screen (Screen 8).

The Air Temp. Trending screen allows the user to view the air temperature (F°) trend vs. time at five (5) locations in the EnergySmart Dryer. The air temperature reading locations are denoted by various colors. The colors associated with the locations are:

- Yellow = Hopper Dry Air Inlet Temperature
- Blue = Hopper Outlet Temperature
- Purple = Dewpoint trending screen
- Light Green = Dry Air Heater On Time %
- Orange = Regeneration Temperature (within the Dryer)

The Air Temp. Trending screen shows a snap shot of the last two (2) hours of operation and records and saves trending data for the last 72-hour period. The scroll buttons near the bottom of the screen allow the user to scroll back to an earlier time or forward to the present time, plus jump to the present time from any time within the trending record.

The user can also view the other system parameters, start the system, stop the system, initiate a system Cool Down or return to the "Login" screen by pressing the applicable buttons on the right of the screen.

Control Function Descriptions (continued)

Screen 12 - Dew Point Trending Screen (optional)

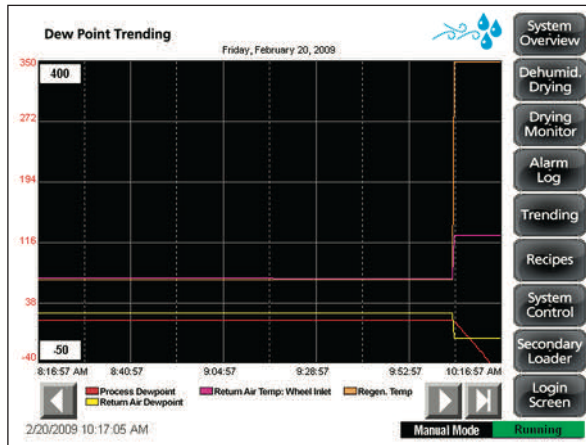

To access the Dew Point Trending Screen (Screen 12):

- 1 Press the "Dew Point" button located on in the center of the Trending Screen (Screen 8).

The Dew Point Trending screen allows the user to view the dew point trend vs time at four (4) locations in the EnergySmart System. The dew point reading locations are denoted by various colors. The colors associated with the locations are:

- Red = Process Dew point
- Yellow = Return Air Dew point
- Purple = Return Air Temp. - Wheel (Desiccant) Inlet
- Orange = Regeneration Temperature (within the Dryer)

The Dew Point Trending screen shows a snap shot of the last two (2) hours of operation and records and saves trending data for the last 72-hour period. The scroll buttons near the bottom of the screen allow the user to scroll back to an earlier time or forward to the present time, plus jump to the present time from any time within the trending record.

The user can also view the other system parameters, start the system, stop the system, initiate a system Cool Down or return to the "Login" screen by pressing the applicable buttons on the right of the screen.

(continued)

Control Function Descriptions (continued)

Screen 13 - Differential Pressure Trending Screen (optional)

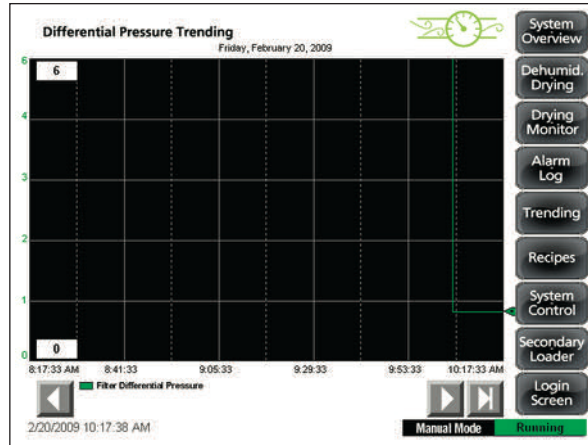

To access the Differential Pressure Trending Screen (Screen 13):

- 1 Press the "Differential Pressure" button** located on in the center of the Trending Screen (Screen 8).

The Differential Pressure Trending screen allows the user to view the differential pressure (PSI) trend vs. time of the EnergySmart Dryer. A dark green color is associated with the Filter (Optional Dust Collector) Differential Pressure.

The Differential Pressure Trending screen shows a snap shot of the last two (2) hours of operation and records and saves trending data for the last 72-hour period. The scroll buttons near the bottom of the screen allow the user to scroll back to an earlier time or forward to the present time, plus jump to the present time from any time within the trending record.

The user can also view the other system parameters, start the system, stop the system, initiate a system Cool Down or return to the "Login" screen by pressing the applicable buttons on the right of the screen.

Control Function Descriptions (continued)

Screen 14 - Alarm Log Screen

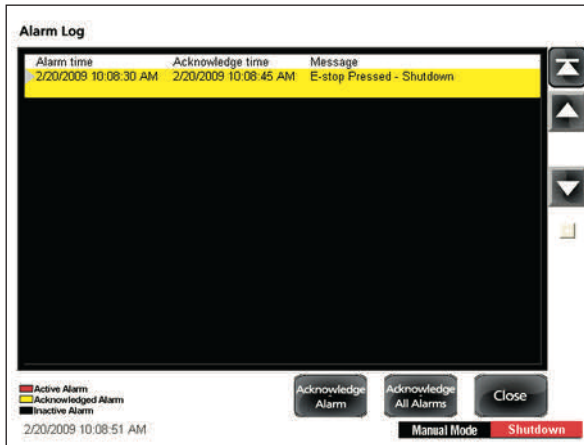

To access the Alarm Log Screen (Screen 14):

1 Press the "Alarm Log" button located on the right side of the screen.

The Alarm Log screen provides the user with a list of the last 200 alarms that have been detected within the EnergySmart Dryer. For each alarm, the alarm time, the acknowledge time (when applicable), and alarm message are listed.

The background colors are associated with the types alarms:

- Red** = Active Alarm
- Yellow** = Acknowledged Alarm
- Black** = Inactive Alarm

For more detailed information concerning the EnergySmart Dryer alarms, [see Troubleshooting section](#).

The scroll buttons on the right of the screen allow the user to scroll up or down through the alarm events or jump to the top or bottom of the alarm log. Near the bottom right of the screen are buttons that allow the user to acknowledge individual alarms, acknowledge all alarms, or close the Alarm Log screen and return to the previous screen.

Press the "Close" button to exit the Alarm Log screen and return to the previously viewed screen.

(continued)

Control Function Descriptions (continued)

Screen 15 - Recipe Screen (optional)

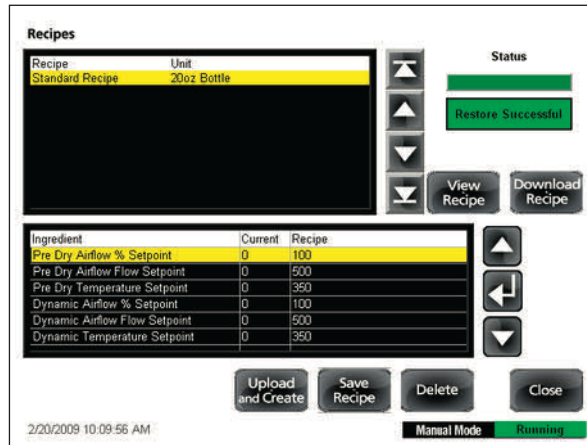

To access the Recipe Screen (Screen 15):

1 Press the "Recipes" button located on the right side of the screen.

The Recipe Screen allows the user to select the specific dryer recipes for their material. Temperature setpoints and air flows can be configured to change an existing recipe or create a new recipe, delete a recipe and upload a recipe, depending upon the application. *See Operation section entitled, Using Dryer Recipes.*

Scroll buttons on the right side of the recipe windows allow the user to scroll through recipes and their individual parameters.

Press the "Close" button to exit the Recipe screen and return to the previously viewed screen.

Control Function Descriptions (continued)

Screen 16 - System Control Screen

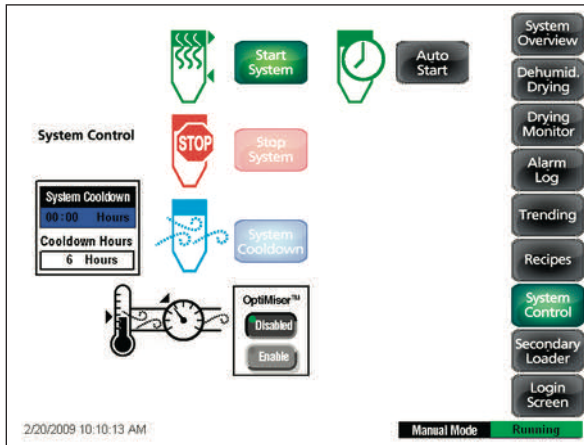

 **NOTE:** Set points boxes are white with heavy black borders. Set points can be changed, if the user has logged in at the proper security level, by pressing the setpoint boxes. This will launch a pop-up keypad window that can be used to change the setpoint. *See Operation section entitled, Example Set Point Change.* After the new setpoint value has been entered, press the "Enter" key to lock in the new setpoint.

To access the System Control Screen (Screen 16):

1 Press the "System Control" button located on the right side of the screen.

The System Control screen allows the user to start or stop the EnergySmart Dryer System, activate the Auto Start timer, set and activate a system cool down timer and to enable or disable the dryer's OptiMizer™ Mode by pressing the associated buttons.

The user can also view the other system parameters, start the system, stop the system, initiate a system Cool Down or return to the "Login" screen by pressing the applicable buttons on the right of the screen.

Control Function Descriptions (continued)

Screen 17 - Auto Start Screen

 **NOTE:** Set points boxes are white with heavy black borders. Set points can be changed, if the user has logged in at the proper security level, by pressing the setpoint boxes. This will launch a pop-up keypad window that can be used to change the setpoint. See [Operation section entitled, Example Set Point Change](#). After the new setpoint value has been entered, press the **"Enter"** key to lock in the new setpoint.

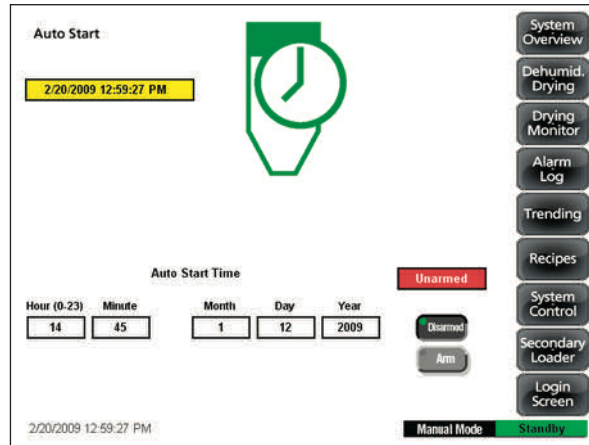

To access the Auto Start Screen (Screen 17):

1 Press the "Auto Start" button located on top right side of the System Control Screen (Screen 16).

The Auto Start screen allows the user to set the start date and time of the EnergySmart Dryer System. If the user is logged-in at the proper security level, the start time (hours and minutes) and date (month, day and year) can be changed from this screen. Once the correct start time has been entered, press the "Armed" button to activate the Auto Start function. Pressing the "Disarmed" button will de-activate Auto Start. The Auto Start function's current status will be displayed on the right side of this screen.

The user can also view the other system parameters, start the system, stop the system, initiate a system Cool Down or return to the "Login" screen by pressing the applicable buttons on the right of the screen.

Control Function Descriptions (continued)

Screen 18 -Secondary Hopper Loader Screen (optional)

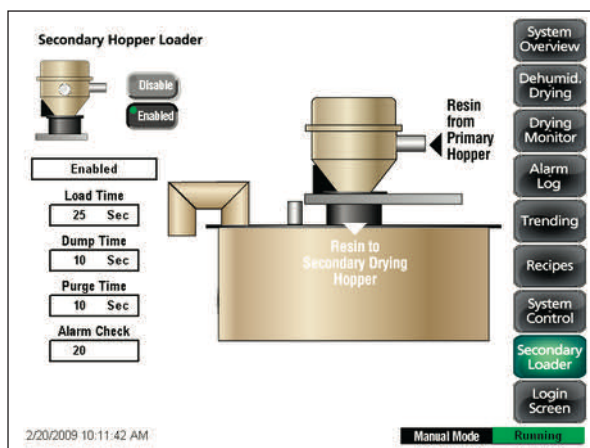

NOTE: Set points boxes are white with heavy black borders. Set points can be changed, if the user has logged in at the proper security level, by pressing the setpoint boxes. This will launch a pop-up keypad window that can be used to change the setpoint. [See Operation section entitled, Example Set Point Change.](#) After the new setpoint value has been entered, press the "Enter" key to lock in the new setpoint.

To access the Secondary Hopper Loader Screen (Screen 18):

- 1 Press the "Secondary Loader" button located on the right side of the screen.

The Secondary Hopper Loader screen allows the user to set the load time, dump time, purge time and alarm checks of the optional receiver. If the user is logged-in at the proper security level, these settings can be changed from this screen. [See specific receiver's manual for correct settings of these parameters.](#) Once the correct times have been entered, press the "Enabled" button to activate the optional secondary receiver. Pressing the "Disabled" button will de-activate the receiver. The receiver's current status will be displayed under the receiver's icon in the top left side of this screen.

The user can also view the other system parameters, start the system, stop the system, initiate a system Cool Down or return to the "Login" screen by pressing the applicable buttons on the right of the screen.

Control Function Descriptions (continued)

Screen 19 - Main Setup Screen

 **NOTE:** Set points boxes are white with heavy black borders. Set points can be changed, if the user has logged in at the proper security level, by pressing the setpoint boxes. This will launch a pop-up keypad window that can be used to change the setpoint. See [Operation section entitled, Example Set Point Change](#). After the new setpoint value has been entered, press the "Enter" key to lock in the new setpoint.

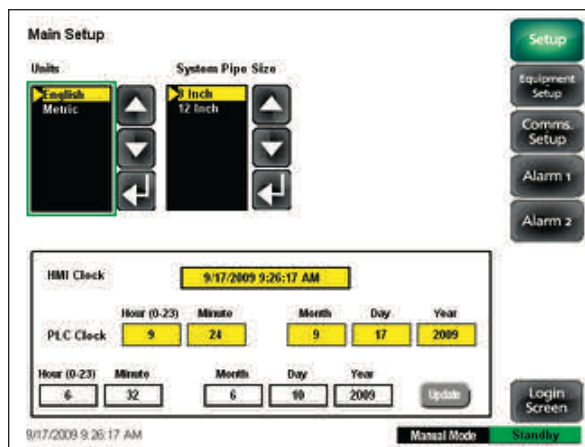

To access the Main Setup Screen (Screen 19):

- 1 Press the "Setup" button located on the right side of Login Screen (Screen 1B), after logging in at the appropriate user level.

The Main Setup screen allows the user to change the system's measurement unit usage (English or Metric), system pipe size (8 and 12 inch {20.3 and 30.5 cm}) and the touch screen control's clock.

To set the dryer control units and system pipe size:

- 1 Use the up and down arrow buttons to make the selection. The current selection will be indicated by a yellow triangle.
- 2 Press the "Enter" button to lock in the current selection.

To update/change the dryer control's clock:

- 1 Press the appropriate box under its heading. Use the pop-up keyboard window to enter the new time and date, and press the "Enter" key to lock in the time.
- 2 Press the "Update" button to update the control's clock.

Control Function Descriptions (continued)

Screen 20 -Equipment Setup Screen

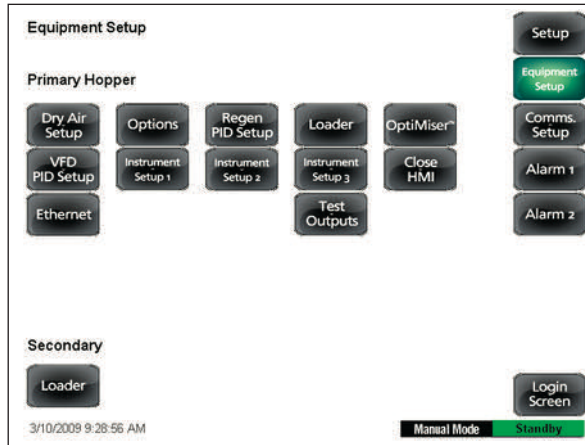

To access the Equipment Setup Screen (Screen 20):

- 1 Press the **"Equipment Setup"** button located on the right side of Main Setup Screen (Screen 19).

The Equipment Setup screen allows the user to access 13 equipment setup buttons. Each button navigates the user to additional setup screens:

- Dry Air Setup
- VFD PID Setup
- Ethernet Setup
- Options Setup
- Instrument 1, 2 and 3 Setup
- Regen PID Setup
- Loader Setup (Primary)
- Test Outputs
- OptiMizer™ Setup
- Close HMI
- Loader Setup (Secondary), if applicable

The user can also view the other system parameters, start the system, stop the system, initiate a system Cool Down or return to the "Login" screen by pressing the applicable buttons on the right of the screen.

 **NOTE:** User must push Login screen first from all Setup screens.

(continued)

Control Function Descriptions (continued)

Screen 21 -Dehumidified Air Circuit Setup Screen

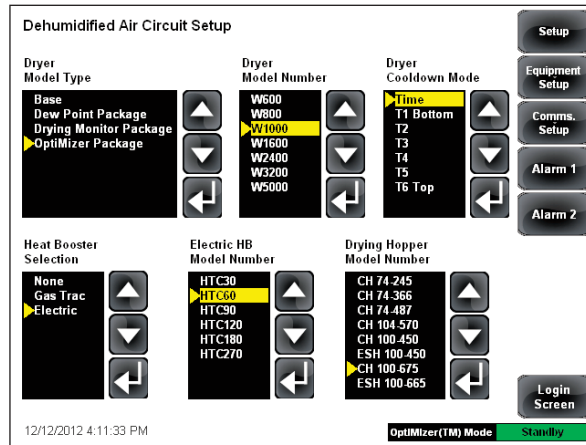

To access the Dehumidified Air Circuit Setup Screen (Screen 21):

- 1 Press the "Dry Air Setup" button located on the Equipment Setup Screen (Screen 20).

From the Dehumidified Air Circuit Setup screen, the user can select the dryer model type the control is currently configured to use, the type of heat booster used in the EnergySmart Dryer System (none, GasTrac, or Electric), the dryer cool down method, model number of the heat booster and the dryer model number.

To configure the EnergySmart Dryer System:

 **NOTE:** Configuration should be completed at the factory prior to shipping.

- 1 Use the up and down arrow buttons to make the appropriate selection. The current selection will be indicated by a yellow triangle.
- 2 Press the "Enter" button to lock in the current selection.

The user can also view the other system parameters, start the system, stop the system, initiate a system Cool Down or return to the "Login" screen by pressing the applicable buttons on the right of the screen.

Control Function Descriptions (continued)

Screen 22 -Dehumidified Air Circuit PID Setup Screen

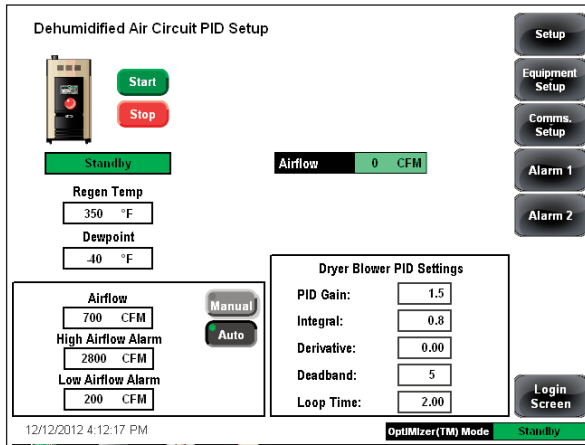

NOTE: Set points boxes are white with heavy black borders. Set points can be changed, if the user has logged in at the proper security level, by pressing the setpoint boxes. This will launch a pop-up keypad window that can be used to change the setpoint. *See Operation section entitled, Example Set Point Change.* After the new setpoint value has been entered, press the "Enter" key to lock in the new setpoint.

NOTE: The air flow setpoint will be shown as "%" if the dryer airflow VFD is set to "Manual". The air flow setpoint will be shown as "CFM" if the dryer is set to "Auto".

To access the Dehumidified Air Circuit PID Setup Screen (Screen 22):

- 1 Press the "VFD PID Setup" button located on the Equipment Setup Screen (Screen 20).

The Dehumidified Air Circuit PID screen allows the user to start or stop the dryer and to select "Auto" or "Manual" operation for the dryer's blower. It also provides the user with the status (running or idle) of the dehumidified air drying circuit blower and information concerning the air flow leaving the blower. It also shows the user the regeneration temperature, dew point, air flow, high air flow alarm, low air flow alarm, PID gain, integral, derivative, Loop Time set point, and the deadband set points.

If the user is logged-in at the proper security level, all setpoints contained on this screen can be changed using the pop-up keypad window.

The user can also view the other system parameters, start the system, stop the system, initiate a system Cool Down or return to the "Login" screen by pressing the applicable buttons on the right of the screen.

Control Function Descriptions (continued)

Screen 23 -Ethernet Setup Screen (optional)

 **NOTE:** Set points boxes are white with heavy black borders. Set points can be changed, if the user has logged in at the proper security level, by pressing the setpoint boxes. This will launch a pop-up keypad window that can be used to change the setpoint. See [Operation section entitled, Example Set Point Change](#). After the new setpoint value has been entered, press the "Enter" key to lock in the new setpoint.

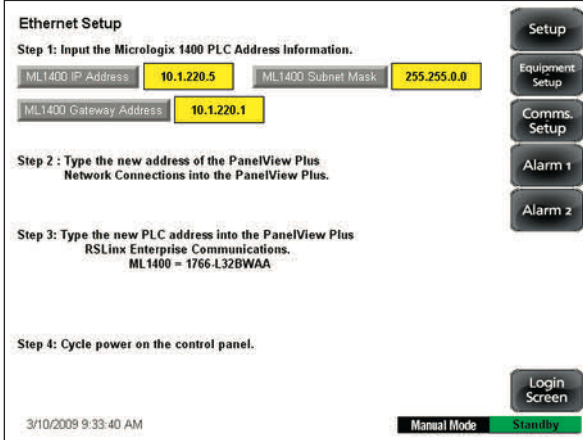

To access the Ethernet Setup Screen (Screen 23):

1 Press the "Ethernet" button located on the Equipment Setup Screen (Screen 20).

The Ethernet Setup screen allows the user to configure the EnergySmart control to communicate within their specific network.

To change any of the IP addresses above:

- 1 Press the grey text box for the specific parameter to be changed** (ML1400 IP Address, ML1400 Subnet Mask and ML1400 Gateway Address).
- 2 Enter the new address within the pop-up keyboard window.**
- 3 Press the "Enter" button to lock in the current selection.**
- 4 Repeat Steps 1-3 for each address.**
- 5 Cycle the dryer's power after all changes are complete.**

The user can also view the other system parameters, start the system, stop the system, initiate a system Cool Down or return to the "Login" screen by pressing the applicable buttons on the right of the screen.

Control Function Descriptions (continued)

Screen 24 -Option Setup Screen

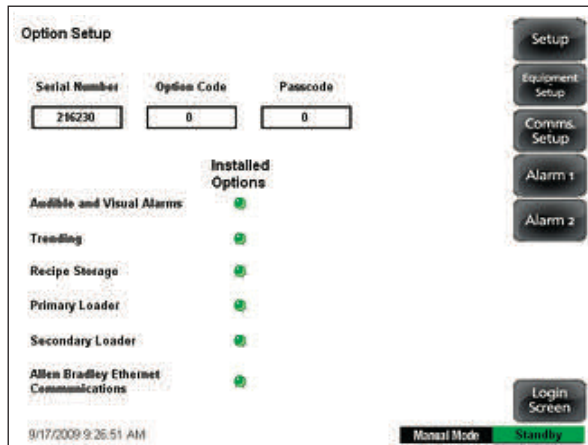

To access the Option Setup Screen (Screen 24):

- 1 Press the "Options" button located on the Equipment Setup Screen (Screen 20).

From the Option Setup screen, the user can select the options currently installed. The options include audible and visual alarms (not installed or installed), trending (not installed or installed), recipe storage (not installed or installed), Allen Bradley ethernet (not installed or installed), primary loader (not installed or installed) and secondary loader (not installed or installed).

The user can also view the other system parameters, start the system, stop the system, initiate a system Cool Down or return to the "Login" screen by pressing the applicable buttons on the right of the screen.

 **NOTE:** You must input an option code and passcode from Conair to install a new option.

Control Function Descriptions (continued)

Screen 25 -Instrument Setup 1 Screen

 **NOTE:** Set points boxes are white with heavy black borders. Set points can be changed, if the user has logged in at the proper security level, by pressing the setpoint boxes. This will launch a pop-up keypad window that can be used to change the setpoint. *See Operation section entitled, Example Set Point Change.* After the new setpoint value has been entered, press the "Enter" key to lock in the new setpoint.

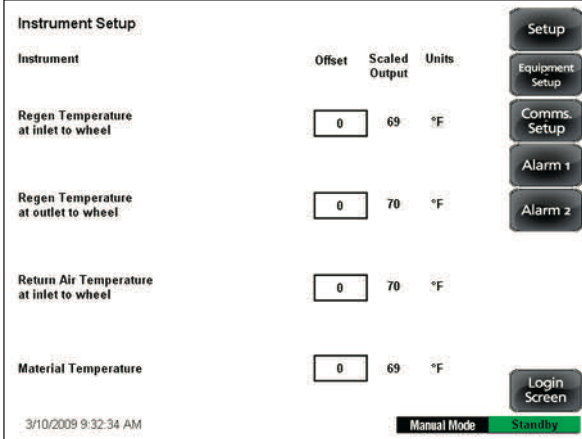

Instrument	Offset	Scaled Output	Units
Regen Temperature at inlet to wheel	0	69	°F
Regen Temperature at outlet to wheel	0	70	°F
Return Air Temperature at inlet to wheel	0	70	°F
Material Temperature	0	69	°F

To access the Instrument Setup 1 Screen (Screen 25):

1 Press the "Instrument 1" button located on the Equipment Setup Screen (Screen 20).

The Instrument Setup 1 screen provides the user with a summary of the EnergySmart Dryer instrument Set points and data for:

- Regeneration Temperature at inlet to wheel
- Regen Temperature at outlet to wheel
- Return Air Temperature at inlet to wheel
- Material Temperature

Where applicable, the settings and data contained on this screen include:

- Offset
- Scaled Output
- Units

If the user is logged-in at the proper security level, all setpoints contained on this screen can be changed using the pop-up keypad window.

The user can also view the other system parameters, start the system, stop the system, initiate a system Cool Down or return to the "Login" screen by pressing the applicable buttons on the right of the screen.

Control Function Descriptions (continued)

Screen 26 -Regeneration Heat PID Setup Screen

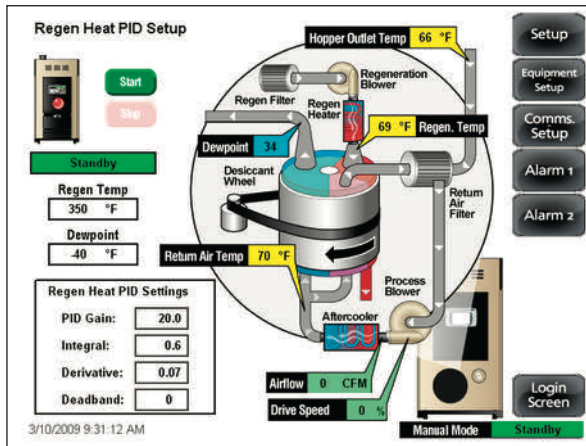

NOTE: Set points boxes are white with heavy black borders. Set points can be changed, if the user has logged in at the proper security level, by pressing the setpoint boxes. This will launch a pop-up keypad window that can be used to change the setpoint. *See Operation section entitled, Example Set Point Change.* After the new setpoint value has been entered, press the "Enter" key to lock in the new setpoint.

To access the Regeneration Heat PID Setup Screen (Screen 26):

- 1 Press the "Regen PID Setup" button located on the Equipment Setup Screen (Screen 20).

The Regeneration Heat PID Setup screen allows the user to Start or Stop the dryer, indicates the dryer's status (running or idle) of the process and information concerning the air flow leaving the blower and its dew point. It also shows the user PID gain, integral, derivative, and the deadband setpoints of the regeneration circuit.

If the user is logged-in at the proper security level, all setpoints contained on this screen can be changed using the pop-up keypad window.

The user can also view the other system parameters, start the system, stop the system, initiate a system Cool Down or return to the "Login" screen by pressing the applicable buttons on the right of the screen.

Control Function Descriptions (continued)

Screen 27 -Instrument Setup 2 Screen

 **NOTE:** Set points boxes are white with heavy black borders. Set points can be changed, if the user has logged in at the proper security level, by pressing the setpoint boxes. This will launch a pop-up keypad window that can be used to change the setpoint. See [Operation section entitled, Example Set Point Change](#). After the new setpoint value has been entered, press the "Enter" key to lock in the new setpoint.

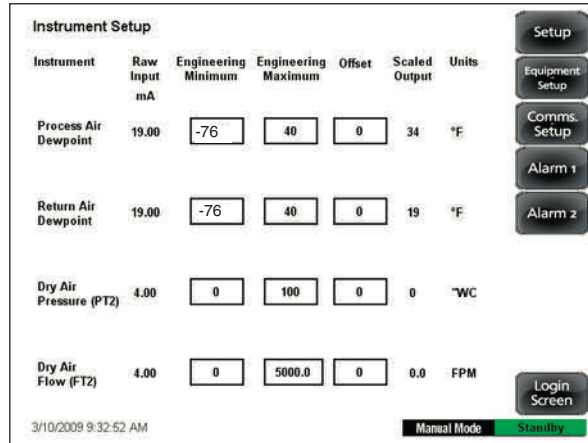

Instrument	Raw Input mA	Engineering Minimum	Engineering Maximum	Offset	Scaled Output	Units
Process Air Dewpoint	19.00	-76	40	0	34	°F
Return Air Dewpoint	19.00	-76	40	0	19	°F
Dry Air Pressure (PT2)	4.00	0	100	0	0	WC
Dry Air Flow (FT2)	4.00	0	5000.0	0	0.0	FPM

To access the Instrument Setup 2 Screen (Screen 27):

1 Press the "Instrument 2" button located on the Equipment Setup Screen (Screen 20).

The Instrument Setup 2 screen provides the user with a summary of the EnergySmart Dryer instrument Set points and data for:

- Process Air Dew Point
- Return Air Dew Point
- Dry Air Pressure (PT2)
- Dry Air Flow (FT2)

Where applicable, the settings and data contained on this screen include:

- Raw Input (mA)
- Engineering Minimum
- Engineering Maximum
- Offset
- Scaled Output
- Units

If the user is logged-in at the proper security level, all setpoints contained on this screen can be changed using the pop-up keypad window.

Control Function Descriptions (continued)

Screen 28 -Secondary Hopper Loader Setup Screen (optional)

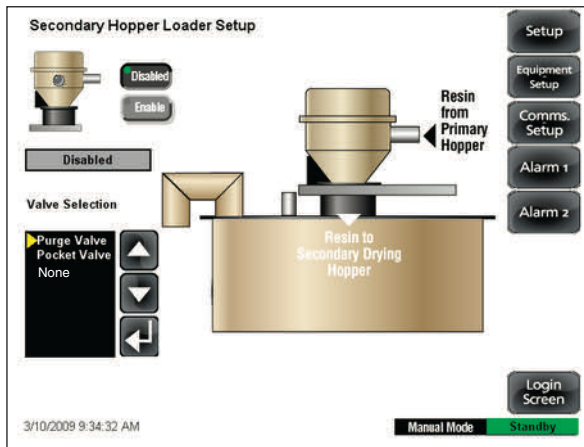

To access the Secondary Hopper Loader Setup Screen (Screen 28):

- 1 Press the "Loader" button** located in the bottom left side and under the heading "Secondary" of the Equipment Setup Screen (Screen 20).

The Secondary Hopper Loader Setup screen allows the user to enable or disable the optional receiver and to choose the type of purge valve working with the receiver.

To select the type of valve:

- 1 Use the up and down arrow buttons to make the selection.** The current selection will be indicated by a yellow triangle.
- 2 Press the "Enter" button to lock in the current selection.**

The user can also view the other system parameters, start the system, stop the system, initiate a system Cool Down or return to the "Login" screen by pressing the applicable buttons on the right of the screen.

Control Function Descriptions (continued)

Screen 29 - Primary Hopper Loader Setup Screen (optional)

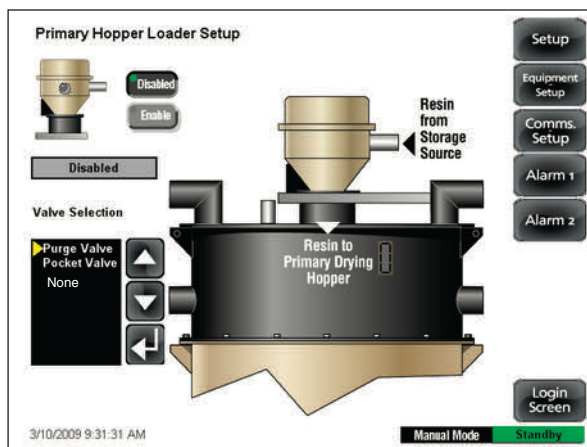

To access the Primary Hopper Loader Setup Screen (Screen 29):

1 Press the "Loader" button located on the Equipment Setup Screen (Screen 20).

The Primary Hopper Loader Setup screen allows the user to enable or disable the optional receiver and to choose the type of purge valve working with the receiver.

To select the type of valve:

1 Use the up and down arrow buttons to make the selection. The current selection will be indicated by a yellow triangle.

2 Press the "Enter" button to lock in the current selection.

The user can also view the other system parameters, start the system, stop the system, initiate a system Cool Down or return to the "Login" screen by pressing the applicable buttons on the right of the screen.

Control Function Descriptions (continued)

Screen 30 -Instrument Setup 3 Screen

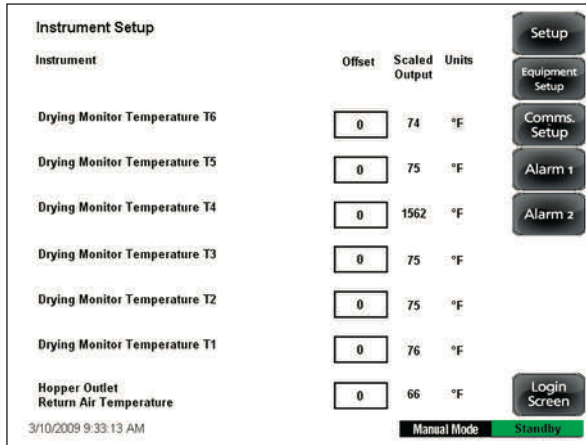

NOTE: Set points boxes are white with heavy black borders. Set points can be changed, if the user has logged in at the proper security level, by pressing the setpoint boxes. This will launch a pop-up keypad window that can be used to change the setpoint. *See Operation section entitled, Example Set Point Change.* After the new setpoint value has been entered, press the "Enter" key to lock in the new setpoint.

To access the Instrument Setup 3 Screen (Screen 30):

1 Press the "Instrument 3" button located on the Equipment Setup Screen (Screen 20).

The Instrument Setup 3 screen provides the user with a summary of the EnergySmart Dryer instrument setpoints and data for:

- Drying Monitor Temperature (T6)
- Drying Monitor Temperature (T5)
- Drying Monitor Temperature (T4)
- Drying Monitor Temperature (T3)
- Drying Monitor Temperature (T2)
- Drying Monitor Temperature (T1)
- Hopper Outlet Return Air Temperature

Where applicable, the settings and data contained on this screen include:

- Offset
- Scaled Output
- Units

If the user is logged-in at the proper security level, all setpoints contained on this screen can be changed using the pop-up keypad window.

(continued)

Control Function Descriptions (continued)

Screen 31 - OptiMizer™ Setup Screen

 **NOTE:** Set points boxes are white with heavy black borders. Set points can be changed, if the user has logged in at the proper security level, by pressing the setpoint boxes. This will launch a pop-up keypad window that can be used to change the setpoint. *See Operation section entitled, Example Set Point Change.* After the new setpoint value has been entered, press the "Enter" key to lock in the new setpoint.

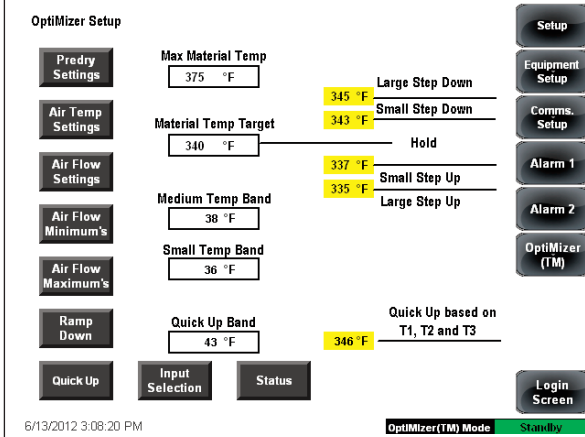

Parameter	Value	Step Values
Max Material Temp	375 °F	
Material Temp Target	340 °F	345 °F (Large Step Down), 343 °F (Small Step Down), 337 °F (Small Step Up), 335 °F (Large Step Up)
Medium Temp Band	38 °F	
Small Temp Band	36 °F	
Quick Up Band	43 °F	346 °F (Quick Up based on T1, T2 and T3)

To access the OptiMizer™ Setup Screen (Screen 31):

- 1 Press the "OptiMizer™" button located on the Equipment Setup Screen (Screen 20).

The OptiMizer™ Setup screen allows the user to set the Maximum Material Temperature, Material Temperature Target, small temperature band, and Quick-Up band. Each temperature setting is material specific, consult your material supplier for the recommended Material Temperature Target and Maximum Material Temperature setpoints.

The temperature band settings are deviation values above or below the Material Temperature Target Set points. *See Operation section entitled, Using the OptiMizer™.*

The user can also view the other system parameters, start the system, stop the system, initiate a system Cool Down or return to the "Login" screen by pressing the applicable buttons on the right of the screen.

Control Function Descriptions (continued)

Screen 32 - Close HMI Screen

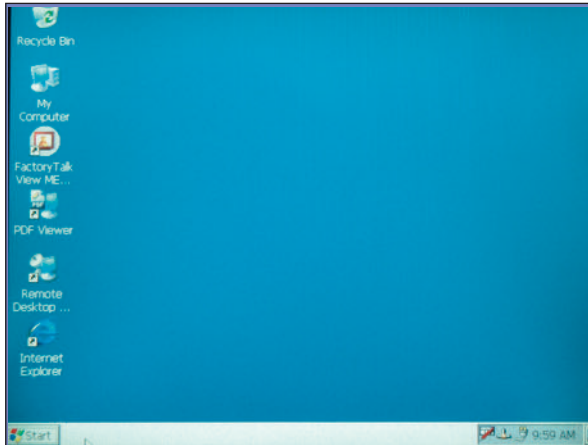

To access the Close HMI Screen (Screen 32):

- 1 Press the "Close HMI" button** located on the Equipment Setup Screen (Screen 20).

Pressing the "Close HMI" button will close the EnergySmart Dryer control software program and return the user to the initial power-up start screen.

To restart the EnergySmart Dryer's control interface:

- 1 Press twice on the FactoryTalkView ME Icon.**
- 2 Touch the "Load Application" button.**
- 3 Select the application. Typically, it is the only application listed.**
- 4 Press the "Load" button.**
- 5 When prompted, "Do you want to replace the terminal's current communication configuration with the application's communication", press the "No" button.**
- 6 Wait for the application to load. Approximately 90 seconds.**
- 7 Press the "Run Application" button.**
- 8 Wait for the application to run.**

(continued)

Control Function Descriptions (continued)

Screen 33 - Test Outputs Screen

 **NOTE:** The test outputs function will be disabled when the dryer system is operating normally.

WARNING: The EnergySmart Dryer should be adjusted and serviced only by a qualified technician who is familiar with construction and operation of this type of equipment.

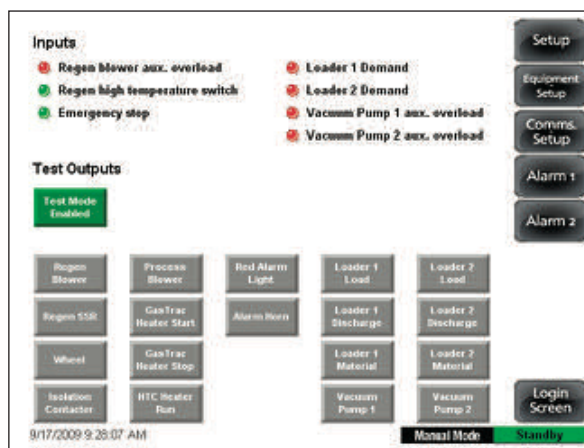

To access the Test Outputs Screen (Screen 33):

1 Press the "Test Outputs" button located on the Equipment Setup screen (Screen 20).

The Test Outputs screen allows the user to test the functionality of the following outputs:

- Regeneration blower
- Regeneration solid state relay (SSR)
- Desiccant wheel
- Isolation contactor
- Process blower
- Process heater -GasTrac/HTC (Start)
- Process heater (Stop)
- Alarm light (Red)
- Alarm horn
- Loader 1 (Load)
- Loader 1 (Discharge)
- Loader 1 (Material)
- Vacuum pump
- Loader 2 (Load)
- Loader 2 (Discharge)
- Loader 2 (Material)
- Vacuum pump 2

To test an output, first press the "Test Mode Disable" button to change to test mode enabled.

1 Press the button of the output to be tested. The output will turn on and remain on until the button is pressed again. The user can also view the other system parameters, start the system, stop the system, initiate a system Cool Down or return to the "Login" screen by pressing the applicable buttons on the right of the screen.

Control Function Descriptions (continued)

Screen 34 - Communications Setup Screen

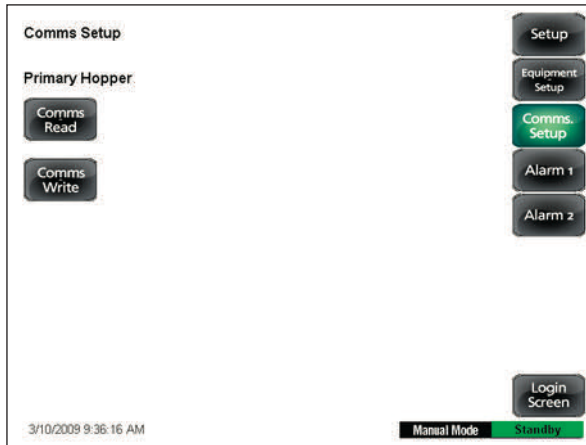

To access the Comms Setup Screen (Screen 34):

- 1 Press the "Comms Setup" button** located on the right side of the Main Setup Screen (Screen 19).

The Comms Setup screen allows the user to access the Read and Write Date Communications Setup Screens (Screens 35 and 36) by pressing the appropriate button.

The user can also view the other system parameters, start the system, stop the system, initiate a system Cool Down or return to the "Login" screen by pressing the applicable buttons on the right of the screen.

Control Function Descriptions (continued)

Screen 35 - Read Data Communications Setup Screen

 **NOTE:** Set points boxes are white with heavy black borders. Set points can be changed, if the user has logged in at the proper security level, by pressing the setpoint boxes. This will launch a pop-up keypad window that can be used to change the setpoint. See *Operation section entitled, Example Set Point Change*. After the new setpoint value has been entered, press the "Enter" key to lock in the new setpoint.

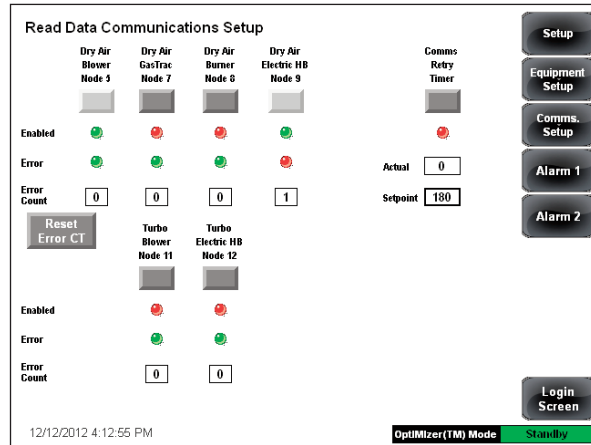

To access the Read Data Communications Setup Screen (Screen 35):

- 1 Press the "Comms Read" button located on the left side of the Comms Setup Screen (Screen 34).

The Read Data Communications Setup screen provides the user with a summary of the communications settings, status and any errors being "read" within the dehumidifying drying circuit of the EnergySmart Dryer System. It allows the user to "Enable" the data read function (indicated by a green LED) or "Disable" the data read function (indicated by a red LED) with the following components within the EnergySmart System by touching the applicable buttons:

- Dry Air Blower
- Dry Air GasTrac (Gas Heater Only)
- Dry Air Burner (Gas Heater Only)
- Dry Air Electric HB (HTC Only)
- Turbo Blower
- Turbo Electric (HB)

This screen also allows the user to see the error count for each communications function, the "Comms (Communications) Retry Counter" setpoint and to reset the error counters ("Reset Error CT" button) for the dehumidifying drying circuit. If the user is logged-in at the proper security level, the "Comms (Communications) Retry Counter" setpoint can be changed on this screen.

Control Function Descriptions (continued)

The user can also view the other system parameters, start the system, stop the system, initiate a system Cool Down or return to the "Login" screen by pressing the applicable buttons on the right of the screen.

NOTE: Set points boxes are white with heavy black borders. Set points can be changed, if the user has logged in at the proper security level, by pressing the setpoint boxes. This will launch a pop-up keypad window that can be used to change the setpoint. *See Operation section entitled, Example Set Point Change.* After the new setpoint value has been entered, press the "Enter" key to lock in the new setpoint.

Screen 36 - Write Data Communications Setup Screen

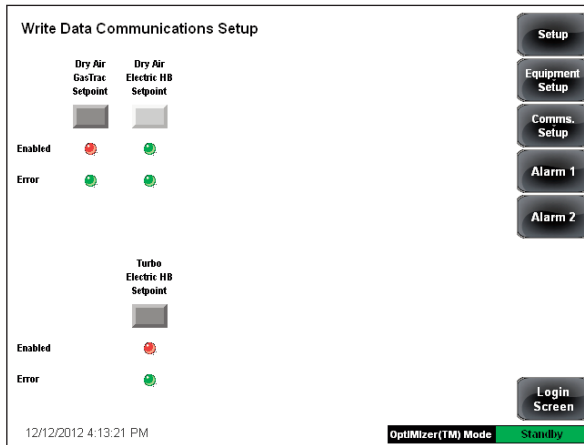

To access the Write Data Communications Setup Screen (Screen 36):

- 1 Press the "Comms Write" button located on the left side of the Comms Setup Screen (Screen 34).

The Write Data Communications Setup screen provides the user with a summary of the communications settings, status and any errors being "written" within the dehumidifying drying circuit of the EnergySmart Dryer System. It allows the user to "Enable" the data write function (indicated by a green LED) or "Disable" the data write function (indicated by a red LED) with the following components within the EnergySmart System by pressing the applicable buttons:

- Dry Air GasTrac setpoint (Gas Heater Only)
- Dry Air Electric HB setpoint (HTC Only)
- Turbo Electric HB setpoint

The user can also view the other system parameters, start the system, stop the system, initiate a system Cool Down or return to the "Login" screen by pressing the applicable buttons on the right of the screen.

(continued)

Control Function Descriptions (continued)

Screen 37 - Alarm Setup 1 Screen

 **NOTE:** Set points boxes are white with heavy black borders. Set points can be changed, if the user has logged in at the proper security level, by pressing the setpoint boxes. This will launch a pop-up keypad window that can be used to change the setpoint. See [Operation section entitled, Example Set Point Change](#). After the new setpoint value has been entered, press the "Enter" key to lock in the new setpoint.

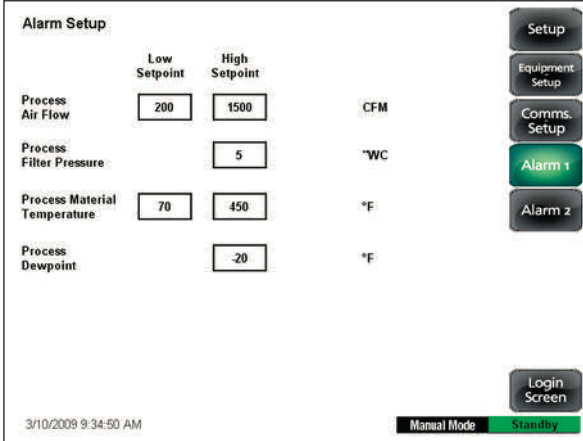

	Low Setpoint	High Setpoint	
Process Air Flow	200	1500	CFM
Process Filter Pressure		5	"WC
Process Material Temperature	70	450	"F
Process Dewpoint		-20	"F

Buttons on the right: Setup, Equipment Setup, Comms. Setup, Alarm 1, Alarm 2, Login Screen.

Bottom status: 3/10/2009 9:34:50 AM, Manual Mode Standby

To access the Alarm Setup 1 Screen (Screen 37):

1 Press the "Alarm Setup 1" button located on the right side of the Main Setup Screen (Screen 19).

The Alarm Setup 1 screen provides the user with a summary of the low and high setpoint, deadbands and the units of measurement associated with each of the following alarms:

- Process Air Flow
- Process Filter Pressure
- Process Material Temperature
- Process Dew Point

If the user is logged-in at the proper security level, all setpoints contained on this screen can be changed using the pop-up keypad window.

The user can also view the other system parameters, start the system, stop the system, initiate a system Cool Down or return to the "Login" screen by pressing the applicable buttons on the right of the screen.

Control Function Descriptions (continued)

Screen 38 - Alarm Setup 2 Screen

	Low Setpoint	High Setpoint	Unit	Hour Setpoint	Minute Setpoint
Drying Monitor Temperature T6	100	400	*F	9	0
Drying Monitor Temperature T5	100	400	*F	8	50
Drying Monitor Temperature T4	100	400	*F	7	40
Drying Monitor Temperature T3	100	400	*F	6	30
Drying Monitor Temperature T2	100	400	*F	5	20
Drying Monitor Temperature T1	100	400	*F	4	10

3/10/2009 9:35:05 AM

Manual Mode Standby

NOTE: Set points boxes are white with heavy black borders. Set points can be changed, if the user has logged in at the proper security level, by pressing the setpoint boxes. This will launch a pop-up keypad window that can be used to change the setpoint. [See Operation section entitled, Example Set Point Change.](#) After the new setpoint value has been entered, press the "Enter" key to lock in the new setpoint.

To access the Alarm Setup 2 Screen (Screen 38):

1 Press the "Alarm Setup 2" button located on the right side of the Main Setup Screen (Screen 19).

The Alarm Setup 2 screen provides the user with a summary of the low, high, minutes and hour setpoints and units of measurement associated with each of the following alarms:

- Drying Monitor Temperature (T6)
- Drying Monitor Temperature (T5)
- Drying Monitor Temperature (T4)
- Drying Monitor Temperature (T3)
- Drying Monitor Temperature (T2)
- Drying Monitor Temperature (T1)

If the user is logged-in at the proper security level, all setpoints contained on this screen can be changed using the pop-up keypad window.

The user can also view the other system parameters, start the system, stop the system, initiate a system Cool Down or return to the "Login" screen by pressing the applicable buttons on the right of the screen.

EnergySmart Dryer System Security Levels

There are three (3) security levels within the EnergySmart Dryer System control available to the customer. The EnergySmart Dryer System is shipped with the password security level set at "Supervisor". For information on how to change security levels, contact your Conair Technical Service representative.

The following table and accompanying text gives an overview of the security levels and description of the functions available at each level.

EnergySmart™ PET Drying System Security Levels					
Security Codes	Levels	A	B	C	
DEFAULT	Level A	✓			
OPER	Levels A & B	✓	✓		
SUPER	Levels A, B, & C	✓	✓	✓	

DEFAULT (Default) Level A

- Start and stop at the system level
- Start and stop individual equipment

OPER (Operator) Levels A & B

- Change date and time
- Start and stop at the system level
- Start and stop individual equipment
- Change operating setpoints
- Change alarm setpoints

EnergySmart Drying System Security Levels *(continued)*

SUPER (Supervisor) Levels A, B, & C

- Change date and time
- Start and stop at the system level
- Start and stop individual equipment
- Change operating setpoints
- Change alarm setpoints
- Go into setup menus
- Add equipment in the setup menus
- Instrument setup
- Variable frequency drive setup
- Shutdown RSView (Close HMI)
- Recipes

EnergySmart Dryer System Modbus Communications

Data from the following EnergySmart Dryer System components are communicated via the programmable logic controller (PLC) located in the control panel.

EnergySmart™ Component	Node Address
Dryer Variable Frequency Drive (VFD)	5
Dry Air GasTrac Single Loop Temperature Controller (TC)	7
Dry Air GasTrac Flame Controller (FC)	8
Dry Air Electric HTC	9
Turbo Blower	11
Turbo Electric HB	12

EnergySmart Dryer System Modbus Communications (continued)

One message is polled every 2/10 of a second. It takes 2.2 seconds to obtain data from all EnergySmart Dryer system components. If a component fails to respond nine (9) times when polled, it is removed from the poll list. The communication failure is indicated with an alarm message on the operator interface terminal. The component that failed is put back into the poll list when the “Alarm Acknowledge” button is pressed on the Alarm Log Screen (Screen 14), or after 300 seconds by the Communications (Comms) Retry Timer.

Each individual message command can be disabled by a Supervisor on the Read Data Communication screen (Screen 35).

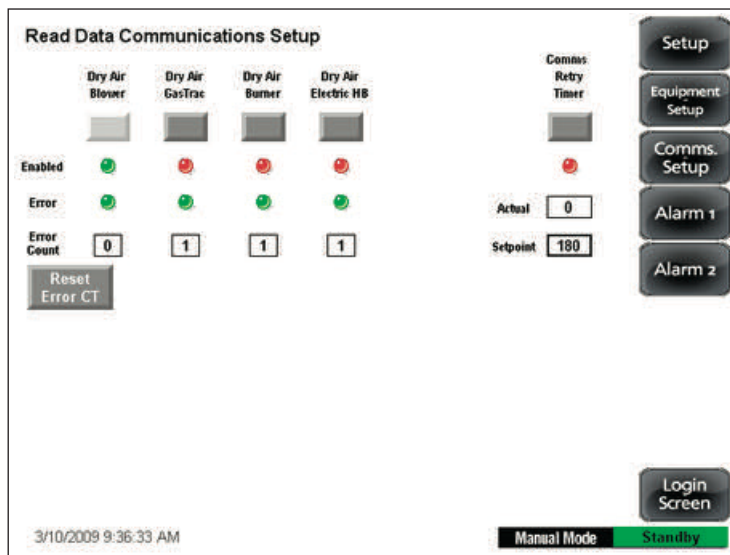

This could be necessary if there is a failure of the communications hardware on a particular component. When communications is operating properly, the error count number will not increase. When one component has a communications problem it affects the whole network. You will see the error count numbers start to increase when this occurs.

Starting the EnergySmart Dryer System

 **NOTE:** Always verify process setpoint against recipe setpoint so that material or equipment is not damaged.

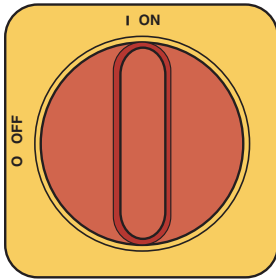

Without OptiMizer™ Mode

To start the EnergySmart Dryer System:

- 1 Turn on the main power to the EnergySmart Dryer and system components.** Check to ensure that the all disconnect dials are in the "On" or "I" position.
- 2 Fill the drying hopper with material** by navigating the System Overview Screen (Screen 2) and pressing the optional receiver's magnifying glass icon. Once at the Primary Loader Screen (Screen 5), set the receiver's load time, dump time and purge times and press the "Enable" button to start loading the CH Hopper.
- 2b If not using the loading function, fill the CH Hopper with material.**
- 3 Navigate to the Dehumidifying Dryer Screen (Screen 4) within the dryer's control.**
- 4 Set the dehumidifying drying circuit air flow to "Manual" mode.**
- 5 Set the air flow setpoint to 100%.**

 **NOTE:** User must be logged in as "Operator" to change these settings.

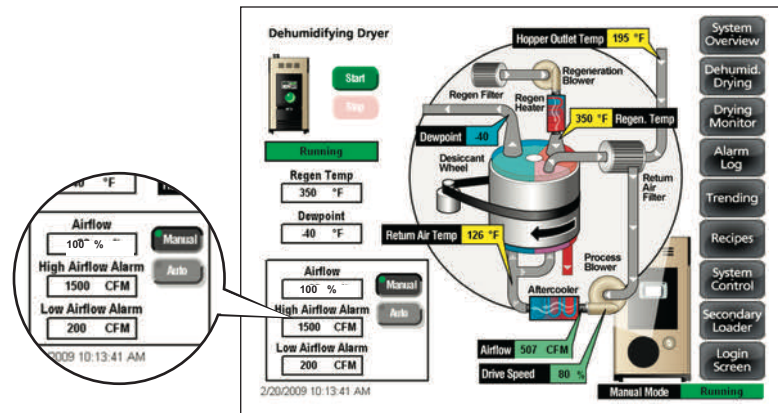

Starting the EnergySmart Dryer System (continued)

Without OptiMizer™ Mode

- 6 Navigate to the Process Heater: Dehumidified Air Circuit Screen (Screen 3) within the dryer's control.

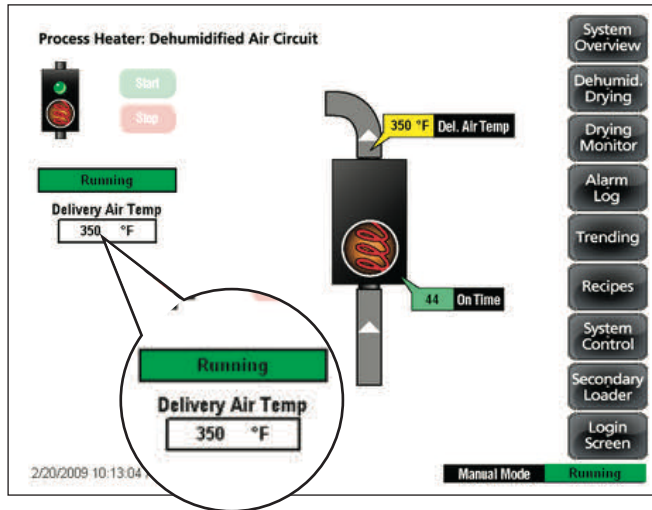

- 7 Enter the Pre-dry Delivery Air Temperature that is to be used with your material. Pre-drying temperatures are specific to the type of material that is processed, consult your material supplier for recommended pre-drying temperatures.

NOTE: Screen 3 shows the type of heater installed in the Dehumidifying Drying Circuit of the EnergySmart Dryer System. If a GasTrac has been installed, the image on the screen will reflect a gas heater (flame). If an HTC has been installed, the image on the screen will reflect an electric heater (heating coil). The screen used in this example reflects an electric heater (heating coil).

NOTE: Set points boxes are white with heavy black borders. Set points can be changed, if the user has logged in at the proper security level, by pressing the setpoint boxes. This will launch a pop-up keypad window that can be used to change the setpoint. See [Operation section entitled, Example Set Point Change](#). After the new setpoint value has been entered, press the "Enter" key to lock in the new setpoint.

Starting the EnergySmart Dryer System (continued)

Without OptiMizer™ Mode

- 8 Navigate to the System Control Screen (Screen 8) after all setpoints have been entered and log out.
- 9 Press the “Start System” button to begin pre-drying your material.

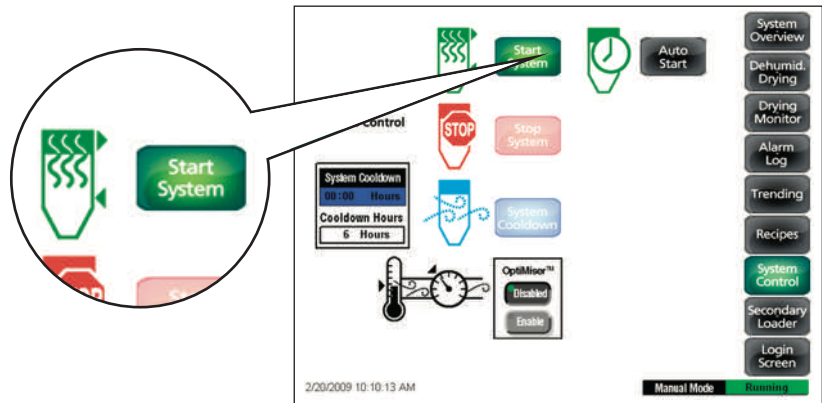

- 10 Navigate to the Material Temperature Trending Screen (Screen 9). It may take a few hours to gather trending data.

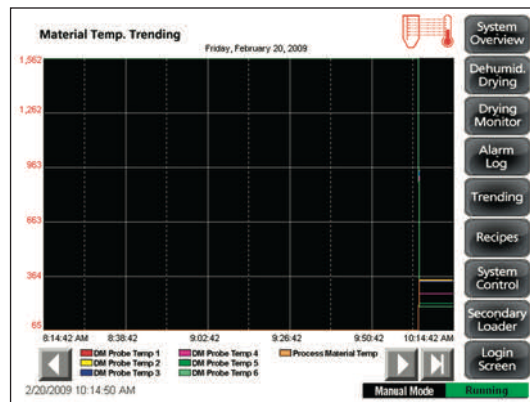

Starting the EnergySmart Dryer System (continued)

Without OptiMizer™ Mode

- 11** Monitor the temperature readout profile on to the Material Temperature Trending Screen (Screen 9) until the material temperature within the hopper reaches and maintains a steady state (approximately 4 to 6 hours).

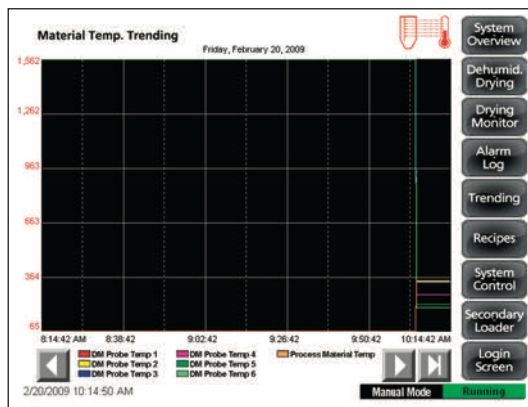

- 12** Start the injection processing/extrusion machine, after the normal pre-dry time is complete (approximately 4 to 6 hours). The injection machine will begin taking material out of the hopper. As the system is running it will take several hours for all components to reach a steady-state running condition. Conair recommends waiting until the system is in a constant steady state before making changes to temperature and air flow setpoints.

Adjusting the EnergySmart Dryer System

(continued)

Without OptiMizer™ Mode

Once your system is running and is in a constant steady state, you can now adjust air flow if desired.

! IMPORTANT: When making changes to air flow on a running system, be careful not to make large changes (more than 10%). Also give the system time to stabilize each time a change is made. Air flow changes will increase or decrease the heater output and the filter pressure drop.

To adjust air flow:

1 Navigate to the Dehumidifying Dryer Screen (Screen 4).

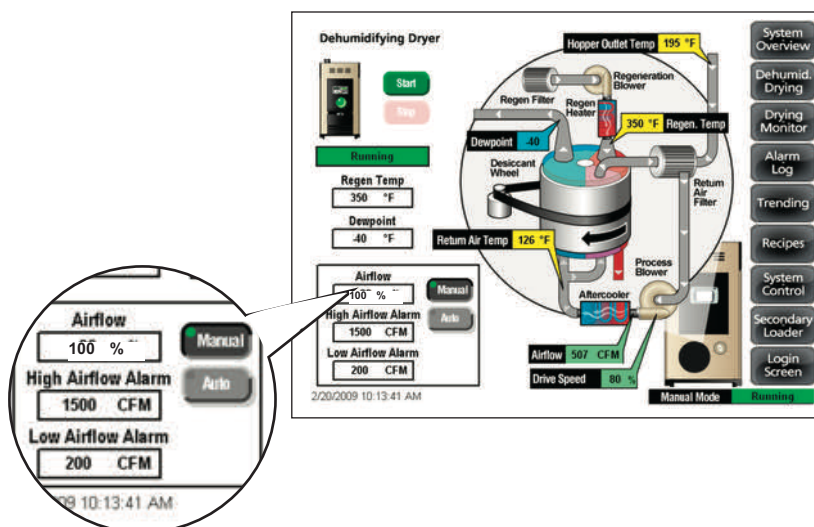

2 Adjust the air flow setpoint of the dryer's process blower. The output of the dryer's process blower is regulated by a variable frequency drive (VFD). The VFD can lower blower's total output to match your processing machine's throughput, reducing power consumption. The air flow can be adjusted manually or automatically. By setting the air flow from Manual mode (%) to Automatic mode (CFM setpoint) the control will automatically set the CFM setpoint to be equal to the value it was running as a percentage. The same is true when switching from Automatic mode to Manual mode. The control will set the % equal to the value it was running as a setpoint. This is done so that the system is not interrupted when changing the air flow control mode. You can choose to operate in either mode based on your preference.

NOTE: Conair recommends using CFM or AutoControl.

Adjusting the EnergySmart Dryer System

(continued)

Without OptiMizer™ Mode

Too large of a change to the air flow can cause an alarm at the heater (HTC or CGT). It will take several hours for the material temperature profile (See [Drying Monitor screen \(Screen 7\)](#)) in the hopper to stabilize based on a change in air flow.

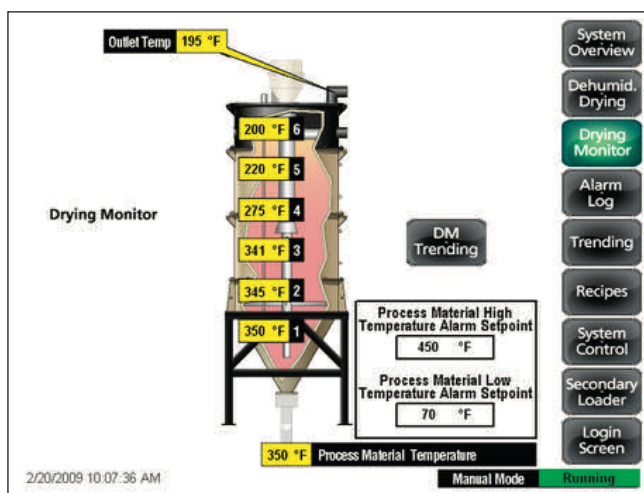

The change in air flow will also affect the return air temperature. Increasing air flow will also increase the hopper outlet temperature.

It is common to see changes in air flow based on the optional receiver dumping material into the top of the hopper. This is due to changes in the system pressure when the receiver valve opens. This change in pressure changes the pressure drop of the system and is normal.

Adjusting the EnergySmart Dryer System

(continued)

Without OptiMizer™ Mode

When the processing machine is turned off and material is not being taken away from the drying hopper, the material in the hopper will settle significantly over time. You may see several receiver dumps into the top of the hopper based on material settling. This settling of material will make it more difficult for air to flow through the hopper and you will see this by an increase in blower speed to maintain the same air flow setpoint (if in Auto). This is normal and will change back once the processing machine begins to take material from the hopper again. If in Manual, you may experience a reduction in airflow.

Temperature - Electric (Hopper Temperature Controllers [HTCs])

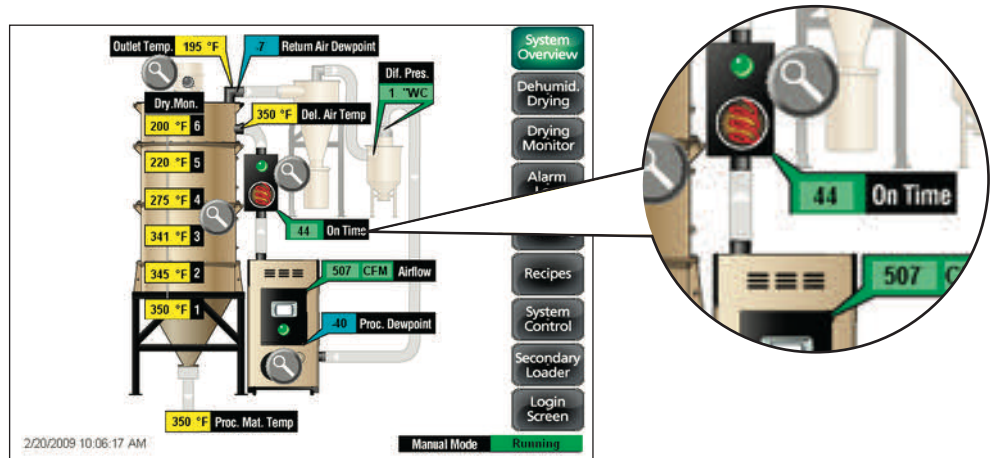

There is one heater for the dry air loop supplied with the EnergySmart™ Dryer System.

It cost more energy to run at higher setpoint temperatures. The on time value shown on the screen above (*See System Overview screen (Screen 2)*) is a percentage of maximum heating, 100% being that the heater is working at maximum capacity.

Adjusting the EnergySmart Dryer System

(continued)

Without OptiMizer™ Mode

Any changes made to the setpoint temperature or air flow will affect the on time value shown. To minimize energy usage, Conair recommends using the lowest setpoint temperature that is required to dry your material and maintain the required material throat temperature. In situations where the incoming material moisture content is low (1000 ppm or less - Winter) you will be able to run lower setpoint temperatures.

Changes to setpoint temperatures will affect the material temperature profile and the hopper outlet temperature.

 **NOTE:** Making too large of a change in setpoint will change the material throat temperature too fast for the processing machine to react. This may cause changes to barrel temperatures, back pressures, and injection pressures.

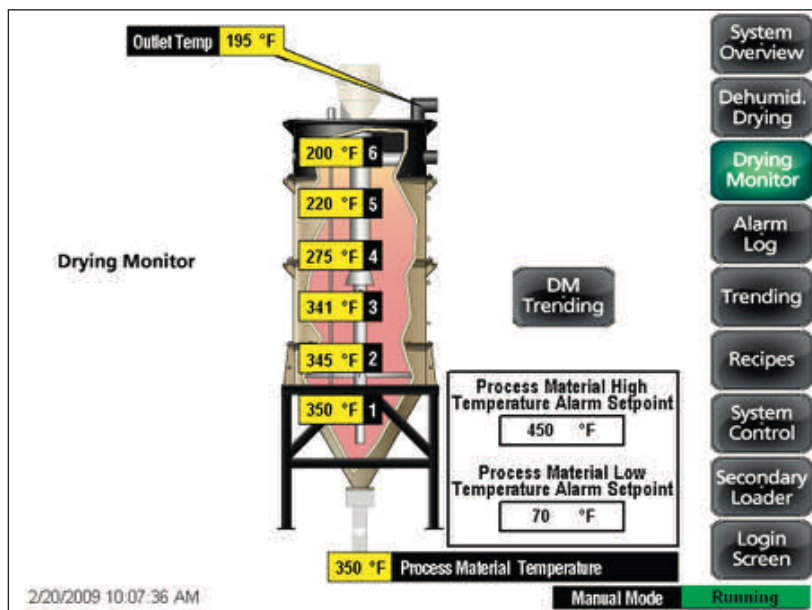

(continued)

Adjusting the EnergySmart Dryer System

(continued)

Without OptiMizer™ Mode

Increasing hopper outlet temperatures or increasing air flow will increase the pressure drop in the filters due to the velocity of the air increasing. Increasing air temperature decreases its density (air expands as it is heated). This decrease in density causes an increase in the velocity of the air. Increased velocity increases the pressure drop.

Temperature - Gas (GasTrac)

In addition to what is described in the "Temperature - Electric (Hopper Temperature Controllers [HTCs])" section, the GasTrac heater will have limited turndown capability. The operating range is affected by how low the flame can be turned down. For example, as the air flow setpoint is lowered, the GasTrac will automatically adjust (turn down) the flame to maintain the same setpoint temperature. Eventually, the GasTrac will reach the minimum limit of its range of turndown capability and any further decrease in air flow will start to increase the temperature above the setpoint due to increased residency time. This condition will activate a deviation alarm and shut down the GasTrac.

Starting the EnergySmart Dryer System

With OptiMizer™ Mode

To start the EnergySmart Dryer System:

- 1 Turn on the main power to the EnergySmart Dryer and system components.** Check to ensure that the all disconnect dials are in the "On" or "I" position.
- 2 Fill the drying hopper with material** by navigating the System Overview Screen (Screen 2) and pressing the optional receiver's magnifying glass icon. Once at the Primary Loader Screen (Screen 5), set the receiver's load time, dump time and purge times and press the "Enable" button to start loading the CH Hopper.
- 2b If not using the loading function, fill the CH Hopper with material.**
- 3 Navigate to the Recipe Screen (Screen 15) within the dryer's control.**
- 4 Select a recipe that has been configured for your material.** When using the EnergySmart Dryer for the first time a default recipe will be the only recipe that can be selected.
- 5 View the recipe and adjust any settings that are required for your material.** *See Operation section entitled, Using the OptiMizer™.*

 **NOTE:** The factory setting for set-point is 350°F.

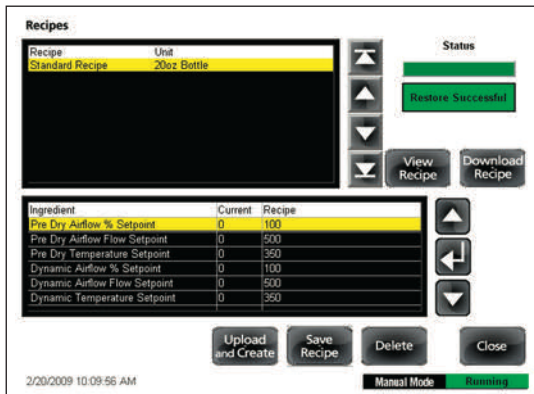
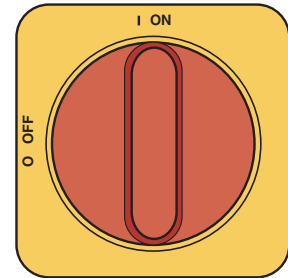

 **NOTE:** You may download recipes to use and store.

(continued)

Starting the EnergySmart Dryer System

With OptiMizer™ Mode

- 6 Navigate to the System Control Screen (Screen 8).
- 7 Enable the OptiMizer™ Mode from the System Control Screen (Screen 8).
See Operation section entitled, Using the OptiMizer™.
- 8 Press the “Start System” button to begin pre-drying your material. The pre-drying stage will use the pre-dry temperature and air flow settings that the user entered within the selected dryer recipe.

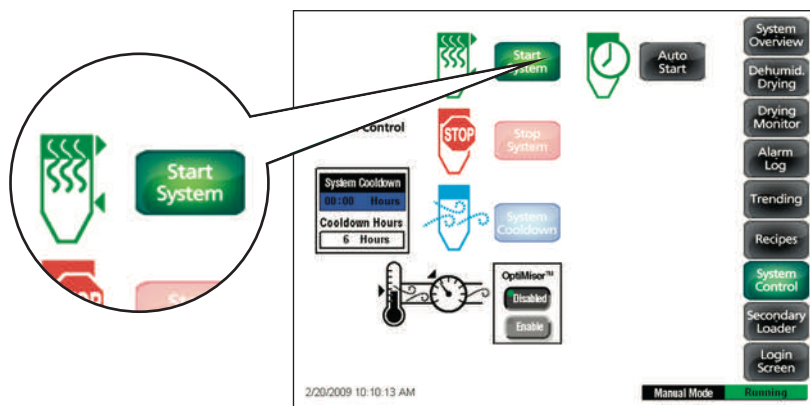

- 9 Start your processing machine when the control displays the message “OK to Start”. This message indicates that the material within the hopper has reached the correct processing temperature and is ready to be used. Additional messages may appear if you haven’t started your injection machine after the initial message:
 - OK to Start - Reminder (4 hours)
 - Start Machine or Cool Down Material (8 hours)
 - Material Should Be Cooled (10 hours)

Starting the EnergySmart Dryer System

With OptiMizer™ Mode

- Once the processing machine has been started, the OptiMizer™ Mode will automatically switch the dryer's control mode from "Pre-dry" to "Dynamic Mode". Over the course of 24 to 48 hours, the OptiMizer™ Mode will fine-tune your drying process, adjusting the air flow and temperature setpoints to the most energy-efficient settings.
- The control will display "System is Optimized" when the dryer's control regulates the optimum temperature and air flow setpoints for your specific material. (This may take 12 to 48 hours to optimize the EnergySmart's setpoints for the first time.)
- Navigate to the Dehumidifying Dryer Screen (Screen 5). Write down the now Optimized temperature and air flow setpoints from the dryer and heater windows.

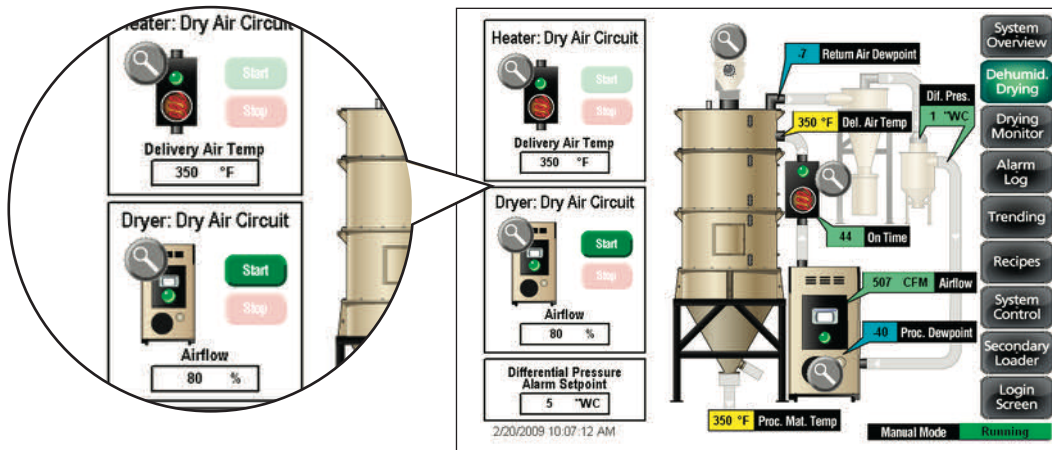

Starting the EnergySmart Dryer System

With OptiMizer™ Mode

- 13** Navigate to the Recipe Screen (Screen 15). Select the same recipe that you started with and enter the new “Dynamic” settings within the appropriate recipe parameters. *See Operation section entitled, Using the OptiMizer™.*

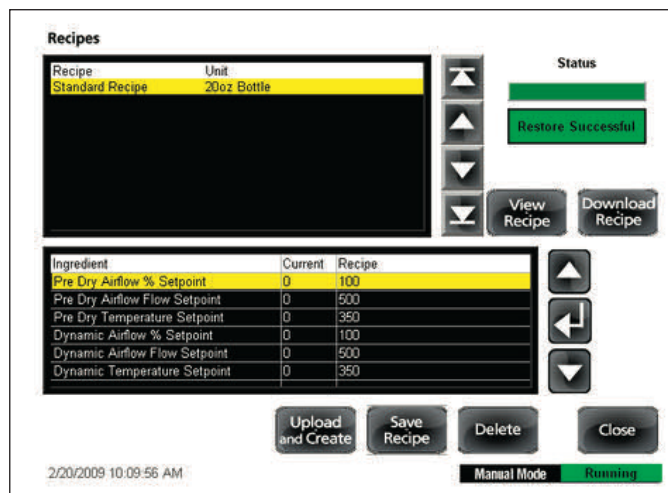

NOTE:

- 0= Standard Default Recipe
- 1= Optimized

- 14** Change the recipe parameter “Optimized” from “0” to “1”. This will indicate that the recipe is Optimized for your specific material and for later use. *See Operation section entitled, Using the OptiMizer™.*

Stopping the EnergySmart Dryer System

There are three (3) ways to stop the EnergySmart Dryer System from the EnergySmart Dryer:

- Pressing the “Stop System” button
- Pressing the “System Cool down” button
- Pressing the Emergency Stop switch

To stop the EnergySmart Dryer System using “System Stop”:

- 1 Stop the processing machine and stop taking material out of the hopper.**
- 2 Navigate to the System Control Screen (Screen 8).**
- 3 Press the "System Stop" button on the System Control Screen (Screen 8).**

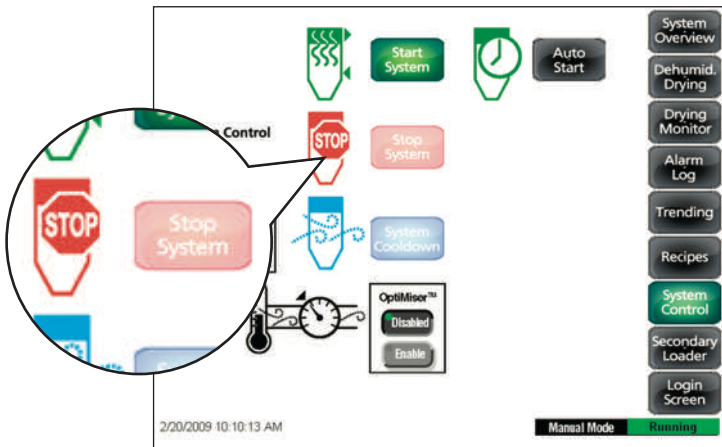

CAUTION: Improper shutdown can cause damage to the EnergySmart Dryer System and its components.

NOTE: Set points boxes are white with heavy black borders. Set points can be changed, if the user has logged in at the proper security level, by pressing the setpoint boxes. This will launch a pop-up keypad window that can be used to change the setpoint. *See Operation section entitled, Example Set Point Change.* After the new setpoint value has been entered, press the "Enter" key to lock in the new setpoint.

NOTE: The material inside the drying hopper will remain hot. If this system will be off for a long period of time, you may want to initiate a "System Cool Down."

When the Stop System function is used, the heater (HTC or GasTrac) will immediately be turned off. The blower in the EnergySmart Dryer will continue to run until the air entering the CH hopper cools to 150°F {65.6°C} or until the ten (10) minute timer has expired.

Stopping the EnergySmart Dryer System (continued)

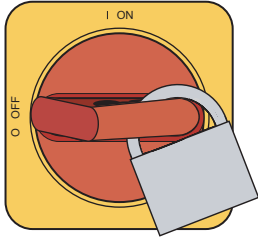

NOTE: If the operator presses the “Stop System” button and then decides use the System Cool down Function, the “System Start” button will have to be pressed, then the “System Cool down” button.

To stop the EnergySmart Dryer System using “System Cool down”:

- 1** Stop the processing machine and stop taking material out of the hopper.
- 2** Navigate to the System Control Screen (Screen 8).
- 3** Press the "System Cool down" button on the System Control Screen (Screen 8.)

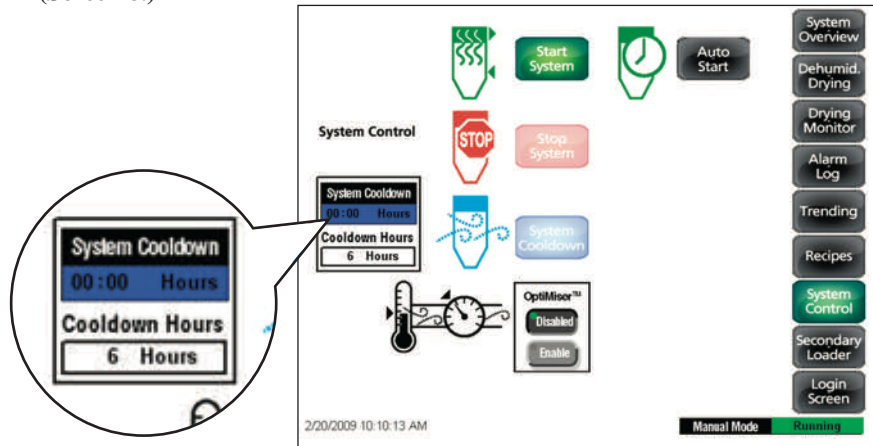

When the System Cool down function is used, the heater (HTC or GasTrac) will immediately be turned off. The blower in the EnergySmart Dryer regen circuit will continue to run for the amount of time set in the System Cool down timer. The time can be set from 1 to 24 hours. If equipped, the temperature probe option can be selected for the Cool Down function.

- 4** Disconnect and lock out the main power if you have stopped the system to perform maintenance or repair.

Stopping the EnergySmart Dryer System

(continued)

To stop the EnergySmart Dryer System in an Emergency:

- 1 Press the “Emergency Stop” button to immediately stop the EnergySmart Dryer System.

 **NOTE:** Using the Emergency Stop button could damage heaters. Only use in case of emergency. Do not use for routine stopping of system.

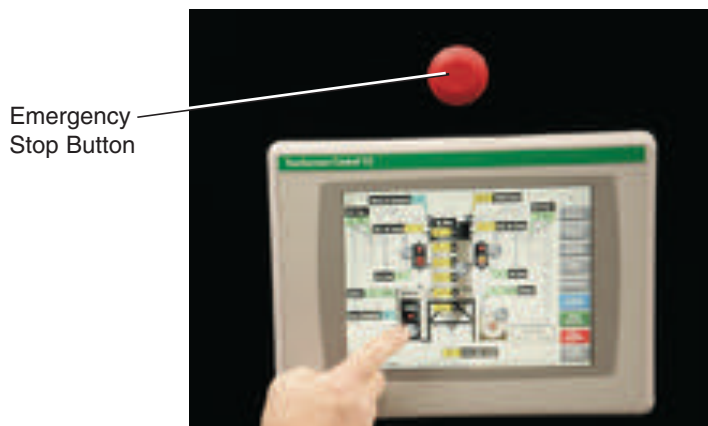

When the “Emergency Stop” button is pressed, the all the components of the EnergySmart Dryer System will immediately shutdown. Air **DOES NOT** continue to circulate to cool down the material in the system or the heaters.

 **NOTE:** It is possible for high temperature switches to open during an emergency shutdown. It may take several minutes for these switches to cool down and reset before the system can be started again.

Using Dryer Recipe (optional)

The EnergySmart Dryer stores and instantly recalls up to 99 drying recipes that are customer-configured for specific materials. Drying recipe storage eliminates manually resetting drying parameters for individual plastic material.

Viewing Dryer Recipes

To view dryer recipes:

- 1 Navigate to the Recipes Screen (Screen 15).

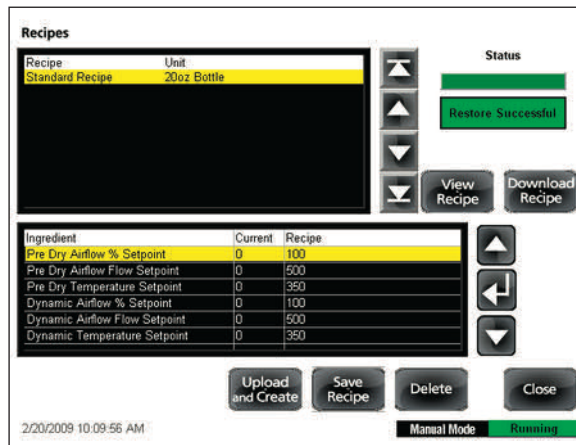

- 2 Use the up and down arrows located to the right of the main recipe selection window to highlight the desired recipe. Arrows are available to scroll through recipes individually or by page.
- 3 Press the “View Recipe” button after highlighting a specific recipe. The recipe’s parameters will be shown in the lower window of the Recipe Screen. Use the up and down arrow buttons located to the right of the recipe parameter window to view additional setpoints.
- 4 Repeat steps 2 and 3 to view additional saved recipes.

Using Dryer Recipes (optional) (continued)

Creating and Saving New Dryer Recipes

To create a new dryer recipe:

- 1 Navigate to the Recipes Screen (Screen 15).

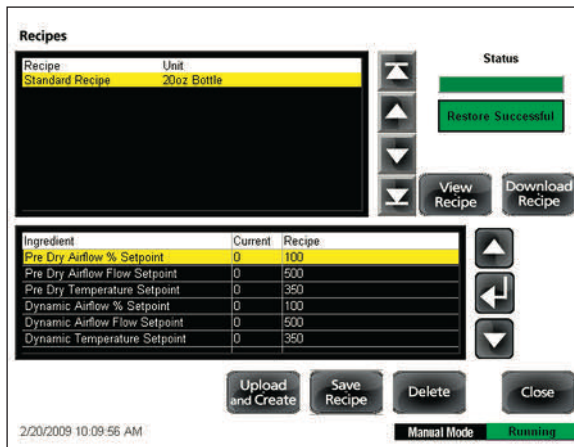

- 2 Press the “Upload and Create” button. A pop-up prompt will ask for a recipe name.
- 3 Press the “Enter” button to activate a pop-up keyboard window. Type in the name of the new recipe and press the “Enter” button. The new recipe will now be displayed in the main recipe selection window.
- 4 Highlight the new recipe by using the up and down arrows located to the right of the main recipe selection window.
- 5 Press the “View Recipe” button. The recipe’s parameters will be shown in the lower window of the Recipe Screen. Use the up and down arrow buttons located to the right of the recipe parameter window to view additional setpoints.
- 6 Use the up and down arrows located to the right of the recipe parameter window to highlight specific recipe parameters.

Using Dryer Recipes (optional) (continued)

Creating and Saving Dryer Recipes

- 7** Press the “Enter” button located to the right of the recipe parameter window to activate a pop-up keyboard window.
- 8** Enter the new parameter setpoint using the keyboard window and then press the “Enter” button. The new setpoint will now be displayed in the recipe’s parameters.
- 9** Repeat Steps 6, 7 and 8 for each required setpoint.
- 10** Press the “Save Recipe” button to save all changes to the recipe.

Using Dryer Recipes (optional) (continued)

Updating Dryer Recipes

To update a dryer recipe:

- 1 Navigate to the Recipes Screen (Screen 15).

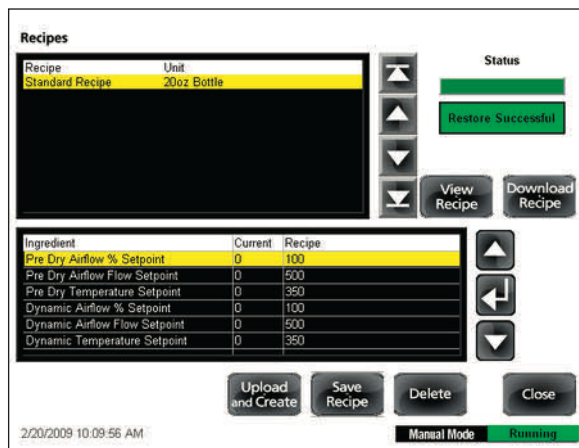

- 2 Highlight the recipe to be updated by using the up and down arrows located to the right of the main recipe selection window.
- 3 Press the “View Recipe” button. The recipe’s parameters will be shown in the lower window of the Recipe Screen. Use the up and down arrow buttons located to the right of the recipe parameter window to view additional setpoints.
- 4 Use the up and down arrows located to the right of the recipe parameter window to highlight specific recipe parameters.
- 5 Press the “Enter” button located to the right of the recipe parameter window to activate a pop-up keyboard window.
- 6 Enter the new parameter setpoint using the keyboard window and then press the “Enter” button. The new setpoint will now be displayed in the recipe’s parameters.
- 7 Repeat Steps 4, 5 and 6 for each required setpoint.
- 8 Press the “Save Recipe” button to save all changes to the recipe.

(continued)

Using Dryer Recipes (optional) (continued)

Deleting Dryer Recipes

To delete a dryer recipe:

- 1 Navigate to the Recipes Screen (Screen 15).

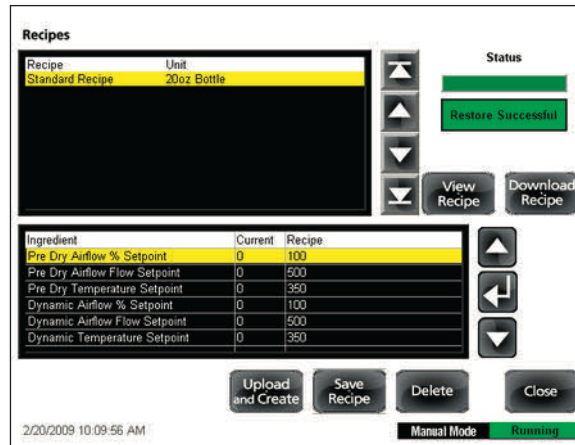

- 2 Highlight the recipe to be deleted by using the up and down arrows located to the right of the main recipe selection window.
- 3 Press the “View Recipe” button. The recipe’s parameters will be shown in the lower window of the Recipe Screen.
- 4 Press the “Delete” button to delete the selected recipe.
- 5 Press the “Yes” button within the confirmation window to delete the recipe.

Using Dryer Recipes (optional) (continued)

Downloading Dryer Recipes

To upload a dryer recipe for use:

- 1 Navigate to the Recipes Screen (Screen 15).

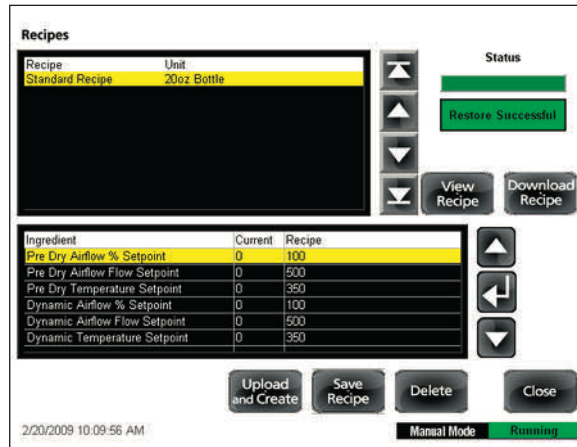

- 2 Highlight the recipe to be uploaded by using the up and down arrows located to the right of the main recipe selection window.
- 2 Press the “View Recipe” button. The recipe’s parameters will be displayed in the “Recipe” column in the recipe parameter window.
- 3 Press the “Download Recipe” button. The recipe’s parameters will be assigned to the dryer system components and will be updated to the “Current” column in the recipe parameter window.
- 4 Start the EnergySmart Dryer System with the new recipe parameters. *See Operation section entitled, Starting the EnergySmart Dryer System, With OptiMizer™ Mode.*

Copying Files from the EnergySmart Dryer System



NOTE: The Touch Screen control Logic Module compact flash card slot supports type I/II compact flash cards.

1A *If the files will be copied onto a USB flash drive. Plug the USB flash disk into the port in the Touchscreen control.* Make sure the flash drive is properly seated in the receptacle.

1B *If the files will be copied onto an external memory card. Install the memory card into the compact flash card slot located on the side of the Touchscreen control Logic Module.* Make sure the memory card is inserted until firmly seated in the slot.

2 **Navigate via the Touch Screen to the "System Login" screen (Screen 1A).** Log into the EnergySmart System as a "Supervisor" *See Operation section entitled, How to Navigate the Control Screens.*

3 **Once you have logged in as a "Supervisor",** navigate to the "System Setup" screen (Screen 20).

4 **Select the "Close HMI" button.** This will stop the application and take you to the desktop.



NOTE: Trending Data is not collected when the application is stopped.

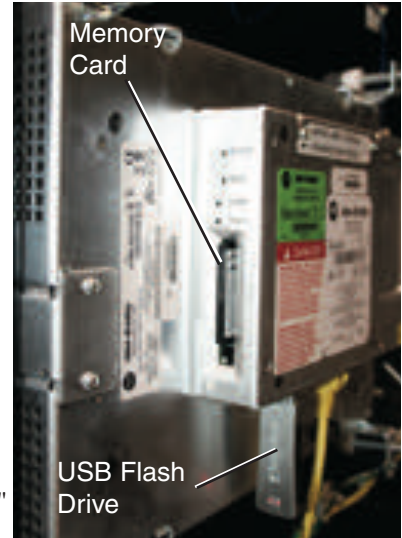

Copying Files from the EnergySmart Dryer System (continued)

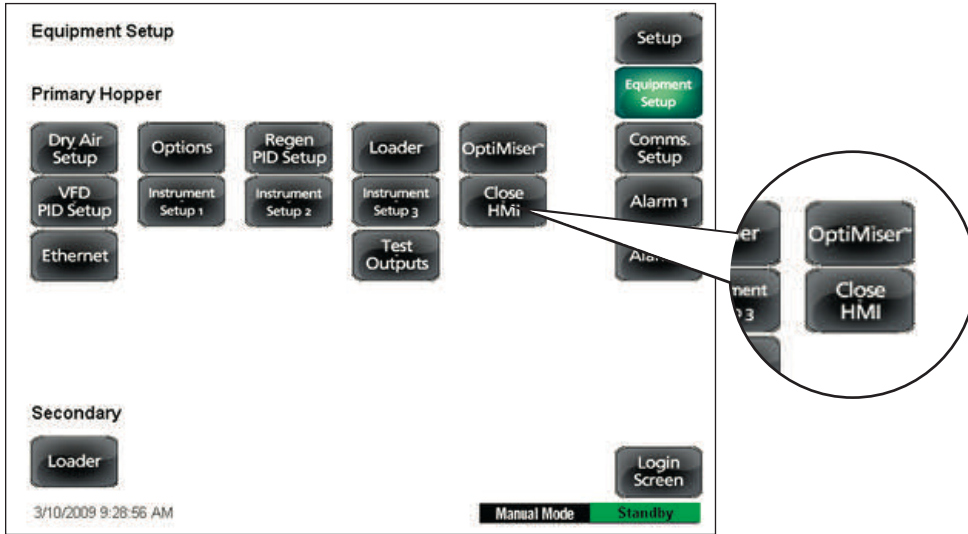

5 Double-click the "My Computer" icon.

6 Browse to the following directory:

```
\Storage Card\Rockwell  
Software\RSViewME\Logs\ES1_TS_Dryer_C\DigLog\Data_Log1
```

You will see two files in this directory: "DataLog1.log" and "DataLog1.tag".

7 **Copy these two files to the clipboard.** First select the two files. This can be done by selecting "Edit" and then "Select All". Then select "Edit" and "Copy".

8A *If using an USB flash drive installed in Step 1.* **Browse to the following directory:** \USB Storage

8B *If using an external memory card installed in Step 1.* **Browse to the following directory:** \Storage Card

(continued)

Copying Files from the EnergySmart Dryer System (continued)

- 9** Once you have browsed to the directory "\USB Storage" or "\Storage Card2", select **"Edit"** and **"Paste"**. The files will be copied onto the flash drive or memory card.

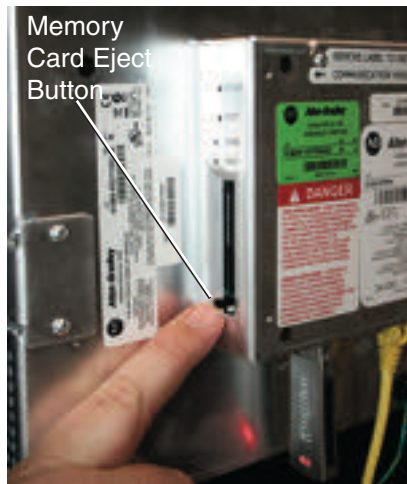

- 10** Remove the USB flash disk from the touchscreen control or press the eject button above the memory card slot to remove the memory card.
- 11A** *If using a USB flash disk.* Plug the SB flash disk into the USB port in your computer.
- 11B** *If using a memory card.* Install the memory card in an appropriate memory card adapter and plug the adapter into your computer.

- 12** Copy the files from the USB flash disk or memory card to a directory on your computer.
- 13** Run the application **"RSView Enterprise File Viewer.exe"**. Contact Conair if you need to obtain a copy of the software.

Copying Files from the EnergySmart Dryer System (continued)

14 Open the "DataLog1.log" file in the RSView Enterprise File Viewer. Be sure to select the same time zone as that in which the files were logged. The file will be converted to a Dbase file and opened so you can view the records.

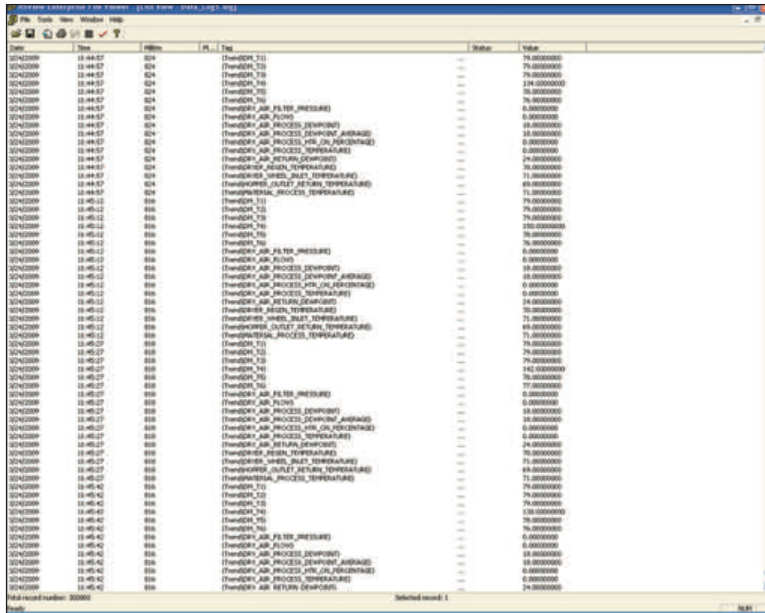

Date	Time	ID#	P#	Tag	Status	Value
10/20/2009	10:44:57	024		FrndrDRY_T13	---	79.00000000
10/20/2009	10:44:57	024		FrndrDRY_T10	---	79.00000000
10/20/2009	10:44:57	024		FrndrDRY_T6	---	139.00000000
10/20/2009	10:44:57	024		FrndrDRY_T5	---	76.00000000
10/20/2009	10:44:57	024		FrndrDRY_AIR_FILTER_MESSAGE	---	0.00000000
10/20/2009	10:44:57	024		FrndrDRY_AIR_FILTER	---	0.00000000
10/20/2009	10:44:57	024		FrndrDRY_AIR_PROCESS_DEHPURF	---	18.00000000
10/20/2009	10:44:57	024		FrndrDRY_AIR_PROCESS_DEHPURF_AVERAGE	---	18.00000000
10/20/2009	10:44:57	024		FrndrDRY_AIR_PROCESS_WITH_CO2_PERCENTAGE	---	0.00000000
10/20/2009	10:44:57	024		FrndrDRY_AIR_PROCESS_TEMP	---	0.00000000
10/20/2009	10:44:57	024		FrndrDRY_AIR_RETURN_DEHPURF	---	24.00000000
10/20/2009	10:44:57	024		FrndrDRY_AIR_RETURN_TEMP	---	70.00000000
10/20/2009	10:44:57	024		FrndrDRY_AIR_FILTER_MESSAGE	---	0.00000000
10/20/2009	10:44:57	024		FrndrDRY_AIR_FILTER	---	0.00000000
10/20/2009	10:44:57	024		FrndrDRY_AIR_PROCESS_DEHPURF	---	18.00000000
10/20/2009	10:44:57	024		FrndrDRY_AIR_PROCESS_DEHPURF_AVERAGE	---	18.00000000
10/20/2009	10:44:57	024		FrndrDRY_AIR_PROCESS_WITH_CO2_PERCENTAGE	---	0.00000000
10/20/2009	10:44:57	024		FrndrDRY_AIR_PROCESS_TEMP	---	0.00000000
10/20/2009	10:44:57	024		FrndrDRY_AIR_RETURN_DEHPURF	---	24.00000000
10/20/2009	10:44:57	024		FrndrDRY_AIR_RETURN_TEMP	---	70.00000000
10/20/2009	10:45:12	006		FrndrDRY_T13	---	79.00000000
10/20/2009	10:45:12	006		FrndrDRY_T10	---	79.00000000
10/20/2009	10:45:12	006		FrndrDRY_T6	---	139.00000000
10/20/2009	10:45:12	006		FrndrDRY_T5	---	76.00000000
10/20/2009	10:45:12	006		FrndrDRY_AIR_FILTER_MESSAGE	---	0.00000000
10/20/2009	10:45:12	006		FrndrDRY_AIR_FILTER	---	0.00000000
10/20/2009	10:45:12	006		FrndrDRY_AIR_PROCESS_DEHPURF	---	18.00000000
10/20/2009	10:45:12	006		FrndrDRY_AIR_PROCESS_DEHPURF_AVERAGE	---	18.00000000
10/20/2009	10:45:12	006		FrndrDRY_AIR_PROCESS_WITH_CO2_PERCENTAGE	---	0.00000000
10/20/2009	10:45:12	006		FrndrDRY_AIR_PROCESS_TEMP	---	0.00000000
10/20/2009	10:45:12	006		FrndrDRY_AIR_RETURN_DEHPURF	---	24.00000000
10/20/2009	10:45:12	006		FrndrDRY_AIR_RETURN_TEMP	---	70.00000000
10/20/2009	10:45:12	006		FrndrDRY_AIR_FILTER_MESSAGE	---	0.00000000
10/20/2009	10:45:12	006		FrndrDRY_AIR_FILTER	---	0.00000000
10/20/2009	10:45:12	006		FrndrDRY_AIR_PROCESS_DEHPURF	---	18.00000000
10/20/2009	10:45:12	006		FrndrDRY_AIR_PROCESS_DEHPURF_AVERAGE	---	18.00000000
10/20/2009	10:45:12	006		FrndrDRY_AIR_PROCESS_WITH_CO2_PERCENTAGE	---	0.00000000
10/20/2009	10:45:12	006		FrndrDRY_AIR_PROCESS_TEMP	---	0.00000000
10/20/2009	10:45:12	006		FrndrDRY_AIR_RETURN_DEHPURF	---	24.00000000
10/20/2009	10:45:12	006		FrndrDRY_AIR_RETURN_TEMP	---	70.00000000
10/20/2009	10:45:12	006		FrndrDRY_T13	---	79.00000000
10/20/2009	10:45:12	006		FrndrDRY_T10	---	79.00000000
10/20/2009	10:45:12	006		FrndrDRY_T6	---	142.00000000
10/20/2009	10:45:12	006		FrndrDRY_T5	---	76.00000000
10/20/2009	10:45:12	006		FrndrDRY_T4	---	77.00000000
10/20/2009	10:45:12	006		FrndrDRY_AIR_FILTER_MESSAGE	---	0.00000000
10/20/2009	10:45:12	006		FrndrDRY_AIR_FILTER	---	0.00000000
10/20/2009	10:45:12	006		FrndrDRY_AIR_PROCESS_DEHPURF	---	18.00000000
10/20/2009	10:45:12	006		FrndrDRY_AIR_PROCESS_DEHPURF_AVERAGE	---	18.00000000
10/20/2009	10:45:12	006		FrndrDRY_AIR_PROCESS_WITH_CO2_PERCENTAGE	---	0.00000000
10/20/2009	10:45:12	006		FrndrDRY_AIR_PROCESS_TEMP	---	0.00000000
10/20/2009	10:45:12	006		FrndrDRY_AIR_RETURN_DEHPURF	---	24.00000000
10/20/2009	10:45:12	006		FrndrDRY_AIR_RETURN_TEMP	---	70.00000000
10/20/2009	10:45:12	006		FrndrDRY_AIR_FILTER_MESSAGE	---	0.00000000
10/20/2009	10:45:12	006		FrndrDRY_AIR_FILTER	---	0.00000000
10/20/2009	10:45:12	006		FrndrDRY_AIR_PROCESS_DEHPURF	---	18.00000000
10/20/2009	10:45:12	006		FrndrDRY_AIR_PROCESS_DEHPURF_AVERAGE	---	18.00000000
10/20/2009	10:45:12	006		FrndrDRY_AIR_PROCESS_WITH_CO2_PERCENTAGE	---	0.00000000
10/20/2009	10:45:12	006		FrndrDRY_AIR_PROCESS_TEMP	---	0.00000000
10/20/2009	10:45:12	006		FrndrDRY_AIR_RETURN_DEHPURF	---	24.00000000

15 Save the file as a database file. Select "Save As" and change to a Dbase file by selecting "dbf" in the drop down box. Click the save button when prompted.

16 The database file can now be opened in Microsoft Access® or other database application software.

Using Dewpoint

- 1 Log in as OPER and navigate to the Dryer screen.

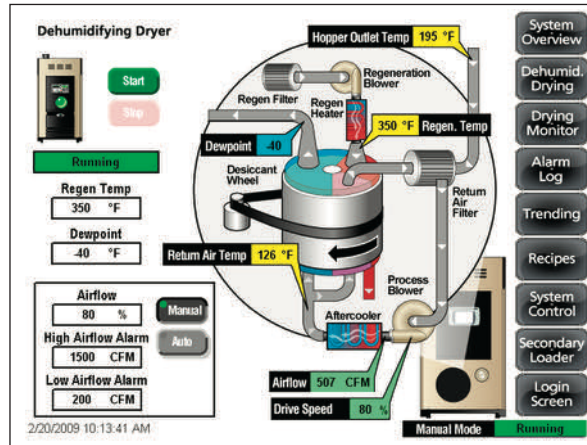

- 2 Press the block for “Dewpoint” to enter setpoint. A number pad will open.
- 3 Enter a value of -39 or higher.
- 4 Click enter to enter your setting. The control will start changing the Regen temp to achieve your setpoint.
- 5 Log out.

Using the OptiMizer™

What is OptiMizer™?

The OptiMizer™ feature in the Single Stage Energy Smart system (ES1) automatically adjusts system air flow and air temperature to achieve maximum energy efficiency while still maintaining the desired material temperature and low moisture levels. The OptiMizer™ system works with either English or Metric units of measurement, however, all of the measurements shown in this operator's manual are the English units Fahrenheit (°F) and Cubic Feet per Minute (CFM).

How Does It Work?

The OptiMizer™ operation is based on unique recipes created by the individual user. These recipes contain the setpoints that meet the needs of each resin drying application. Using the material throat temperature and DMII drying monitor temperatures, the OptiMizer™ system will automatically adjust the air flow and air temperature to achieve these settings. Each recipe is classified as Optimized or non-Optimized. This designation helps determine the path that the control takes in order to deliver dry resin at the desired temperature. The setpoints and system settings shown in this document are the default settings recommended by Conair when using the OptiMizer™ system.

Operation

The operation description in this manual will begin from a cold start. It is also recommended that the airflow control is set to automatic (PID Control). In the single stage system, several factors such as a dirty filter, material shift, and material flow affect the airflow. In manual (VFD % Output) mode, the VFD will not be able to adjust to these changes. In automatic mode, the VFD will adjust automatically to maintain the airflow setpoint.

Non-Optimized Recipe Operation

Typically, the first time a recipe is used it is configured as non-Optimized (described in the Recipe Creation section). When a non-Optimized recipe is used, from a cold start, the system will progress through the following series of modes:

- Initial Delay
- Pre-dry
- OptiMizer™ Delay
- Dynamic Tune Down/Tune Up
- Optimized

Using the OptiMizer™ (continued)

The Initial delay and Pre-dry modes occur when no material is being used. When the dryer is running and the OptiMizer™ is enabled, the initial delay is the first mode the system activates. During both of these modes, the Pre-dry setpoints from the recipe are used for the temperature and air flow. These initial modes in the OptiMizer™ sequence are used to bring the material up to its drying temperature and begin the drying process, before the injection molding machine is started and material is removed from the hopper.

Once the Pre-dry mode is completed, a message will alert the operator that the material is ready and the injection molding machine (IMM) or extruder can be started. In a typical drying application, the Pre-dry mode is designed to provide ready to use material in three to four hours. This message is displayed and should be acknowledged like an alarm. The display is shown below.

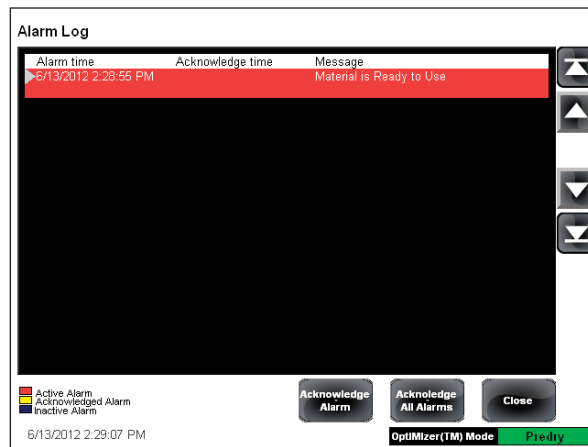

Pre-dry Material Ready to Use Display

Material use is detected using a digital input from the downstream IMM or extruder, or using the material temperature monitored at the machine throat. This temperature is compared to the material temperature setpoint minus the material temperature band. The temperature band is set on the 'OptiMizer™ Input Selection Setup' screen shown below. Once material use is detected, the system will progress through the OptiMizer™ Delay mode to allow the system to reach steady state equilibrium, before any changes are made. During this delay (typically six hours), the system will continue to use the Pre-dry temperature and air flow setpoints.

Using the OptiMizer™ (continued)

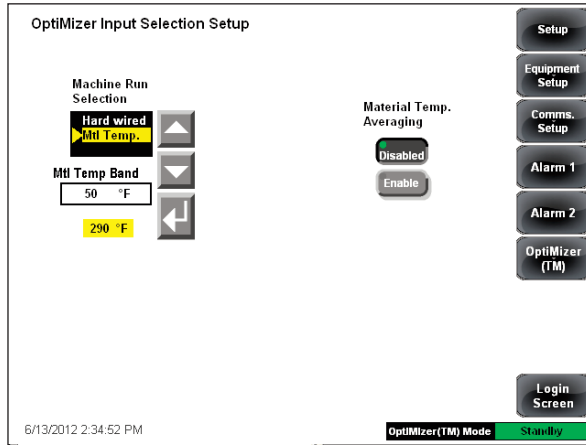

OptiMizer™ Input Selection Setup Screen

The OptiMizer™ Input Selection Setup screen is used to enter the Machine Run Selection information into the controller and enable/disable the Material Temperature Averaging. Due to the nature of the resin flow, the material temperature measured by the Conair RTD probe at the IMM or extruder throat tends to fluctuate greatly. The Material Temperature Averaging, when enabled, smoothes out the temperature signal from the Conair RTD probe. The Machine Run Selection is how the OptiMizer™ determines when the extruder or molding machine is running and material is being used. Graphs that illustrate how the OptiMizer™ uses each selection to determine material usage is shown below.

Using the OptiMizer™ (continued)

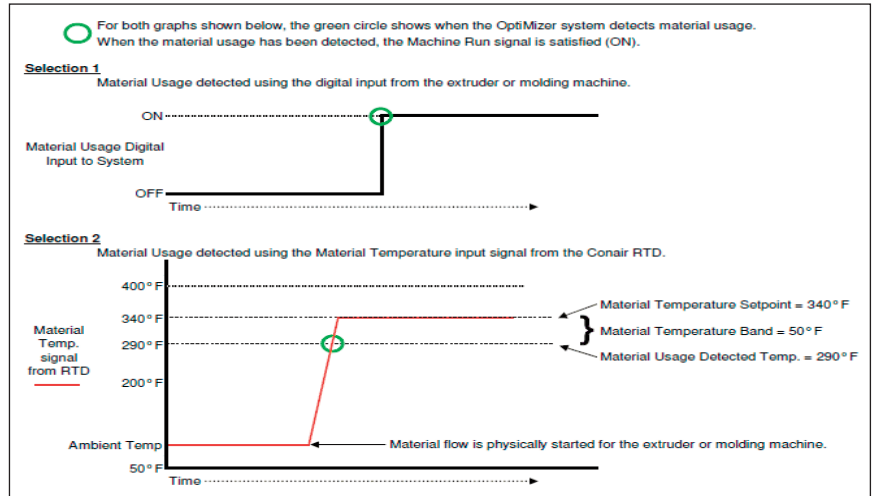

Machine Run Selection/Material Usage Graphs

The Machine Run Selection/Material Usage chart shows how the OptiMizer™ detects material usage. The top graph illustrates the digital input from the extruder or molding machine selection, and the bottom graph shows how the OptiMizer™ uses material temperature signal from the Conair RTD to determine material usage.

 **NOTE:** If this machine run signal is lost during OptiMizer™ operation, the system returns to the Pre-dry system settings and mode of operation. This is done in order to protect the integrity of the resin.

At the completion of the OptiMizer™ Delay, the system will go into the Dynamic Tune Down/Tune Up mode, during which the system begins to make adjustments towards an Optimized state. Since this is a non-Optimized recipe, the system will be seeing these variables for the first time. The adjustments are made in a predetermined order, in small steps over lengthy time intervals. This is by design so that the system can slowly work towards the optimal settings without compromising the integrity or usability of the resin.

Using the OptiMizer™ (continued)

Once the Dynamic Tune process is complete and the system has reached the optimal settings for the first time using this recipe, a message will be displayed prompting the operator to save changes to the current recipe. This message is shown below. The Dynamic recipe setpoints should then be changed to match the current operating parameters, and the recipe configured as Optimized and then saved. Once a recipe has been changed, it has to be downloaded in order for the changes to take place in the OptiMizer™ controller. This procedure is described in the 'Recipe Setup and Management' section. However, if the system is currently running, it is not necessary to download the newly changed and saved recipe to the controller. A download is only required for the next system startup. On the next system startup, the Optimized recipe can be downloaded and the system will operate as described below.

After the Dynamic Tune process is complete, the message below will alert the operator that the system is Optimized and the recipe should be updated. This message is displayed and should be acknowledged like an alarm.

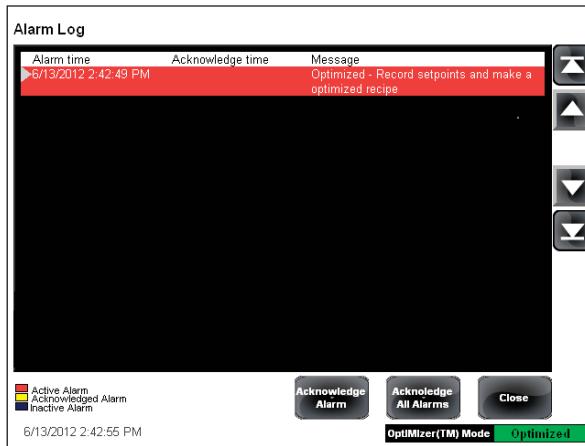

Optimized Message

Using the OptiMizer™ (continued)



NOTE: This Optimized recipe operator message should not be confused with the 'Optimized' system status text that is shown in the bottom right-hand corner of the screens. The system status of 'Optimized' means that the system is in a state of equilibrium and does not need to change any settings in order to maintain the Material Temperature setpoint. The system needs to maintain this state for a period of time before the Optimized recipe message is displayed.

6/13/2012 2:47:35 PM

OptiMizer(TM) Mode Optimized

Optimized System Status Text

Optimized Recipe Operation

An Optimized recipe is one that has already been learned by the system, and has been proven to reach the desired material conditions. When an Optimized recipe is downloaded and used in the OptiMizer™ system, the sequence of operation is slightly different. Upon Dryer start-up with OptiMizer™ enabled, the Initial delay, Pre-dry, and OptiMizer™ Delay modes will function exactly as described in the non-Optimized section above. The difference in operation begins when the OptiMizer™ Delay time has elapsed, and the OptiMizer™ begins making changes. After the delay is complete, the system will go into Ramp Down mode. In Ramp Down, the system starts with the Pre-dry setpoints from the recipe and works through the Ramp Down sequence to achieve the Dynamic setpoints from the recipe. In this mode, the control system makes larger, quicker steps when working towards the Optimized or Dynamic setpoints. It can do this with more confidence because the system has already been proven to run at these Optimized setpoints during a previous run.

Once the Tune Down or Ramp Down mode is complete, the control system goes into Dynamic mode. While in the Dynamic mode, the system continuously monitors changes to the system conditions and setpoints. If deemed necessary by the OptiMizer™ control, a Tune Up/Tune Down or Quick Up step may be initiated in order to keep the material conditions at the correct levels.

Using the OptiMizer™ (continued)

OptiMizer™ Setup

Before the OptiMizer™ function is started, the operator should confirm that the setup parameters are set properly. These parameters are factory set at predetermined default settings and normally do not need changed. However, it is important to become familiar with these settings and confirm they are set accordingly. The actual OptiMizer™ enable is on the ‘System Control’ HMI screen. On this screen the Enable/Disable OptiMizer™ button is at the bottom of the screen as shown below. When the OptiMizer™ is enabled, the system performs the functions associated with the OptiMizer™. The OptiMizer™ needs to be disabled when manual dryer operation is desired.

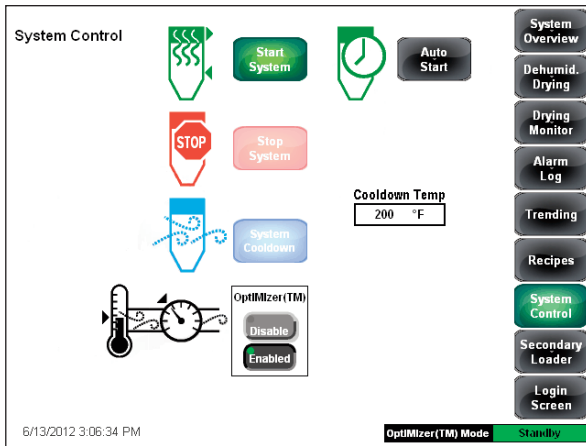

System Control Screen

In order to find the OptiMizer™ settings screens on the ES1 control HMI:

- 1** Go to the Login screen.
- 2** From the Login screen, login under the “Super” level user name and password.
- 3** Use the following navigation button path Setup > Main Setup > Equipment Setup > OptiMizer™. This navigation path is shown on the following screen shots.

(continued)

Using the OptiMizer™ (continued)

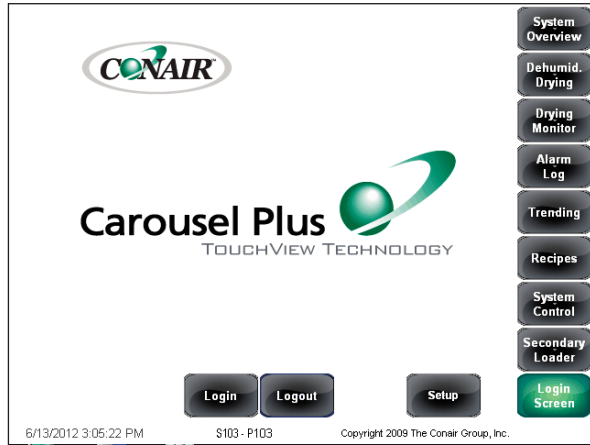

System Login Screen

The System Login Screen is used as the main navigation and security access point for the entire system.

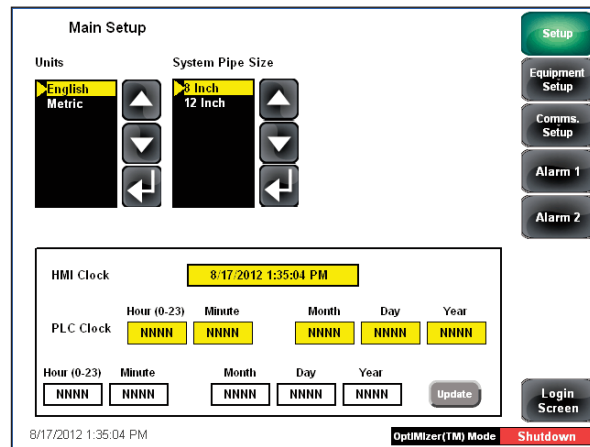

Main Setup Screen

The Main Setup Screen is used to select the units that will be displayed on the screens, the system pipe size, and also to set the HMI and PLC clocks.

Using the OptiMizer™ (continued)

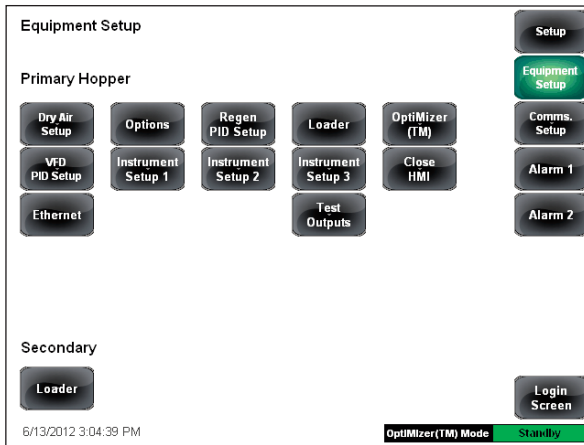

Equipment Setup Screen

From the 'Equipment Setup' screen, the 'OptiMizer™' navigation button is used to open the 'OptiMizer™ Setup' screen. The various screens that are used to configure and use the OptiMizer™ function are shown below.

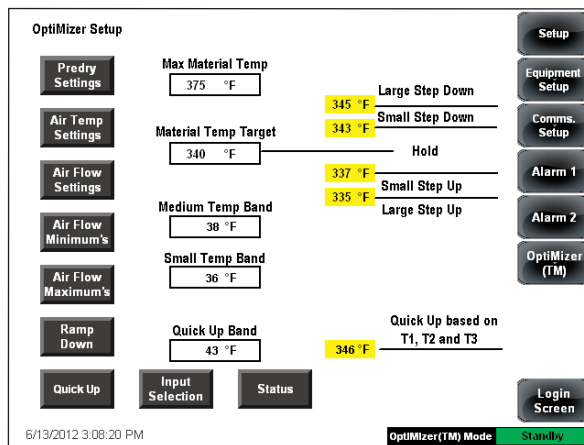

OptiMizer™ Setup Screen

The OptiMizer™ Setup screen is the primary navigation page for the OptiMizer™ function. It also shows the main temperature targets and temperature bands used in the OptiMizer™. The temperature setpoints can also be changed from this screen.

Using the OptiMizer™ (continued)

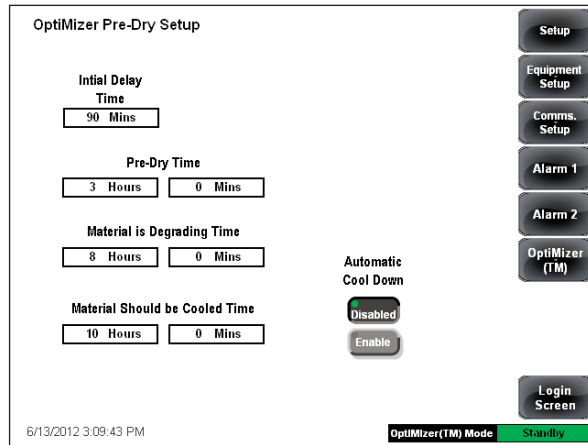

OptiMizer Pre-Dry Setup

Initial Delay Time
90 Mins

Pre-Dry Time
3 Hours 0 Mins

Material is Degrading Time
8 Hours 0 Mins

Material Should be Cooled Time
10 Hours 0 Mins

Automatic Cool Down
Disabled
Enable

Setup
Equipment Setup
Comms. Setup
Alarm 1
Alarm 2
OptiMizer (TM)
Login Screen

6/13/2012 3:09:43 PM
OptiMizer(TM) Mode Stability

OptiMizer™ Pre-dry Setup Screen

The OptiMizer™ Pre-dry Setup screen shows all of the time values for the Pre-dry mode of OptiMizer™ operation. All of the Pre-dry operator messages are activated based on these time values. The ‘Automatic Cool down’ Enable/Disable push-buttons are also on this screen. Automatic Cool Down refers to how the system reacts when the system reaches the ‘Material Should be Cooled Time’ limit during Predry, or if the system is in the Shutdown mode. If the automatic Cool Down is enabled, the system will go through either the timed or temperature Cool Down without operator intervention when the “Material Should be Cooled Time” is reached.

Using the OptiMizer™ (continued)

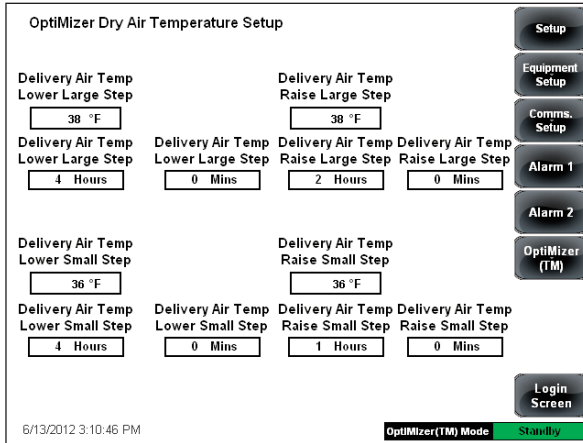

OptiMizer™ Dry Air Temperature Setup Screen

The OptiMizer™ Dry Air Temperature Setup screen shows all of the setpoints for the Delivery Air Temperature when the OptiMizer™ function is running. These setpoints are used during the Tune Up/Down mode of operation.

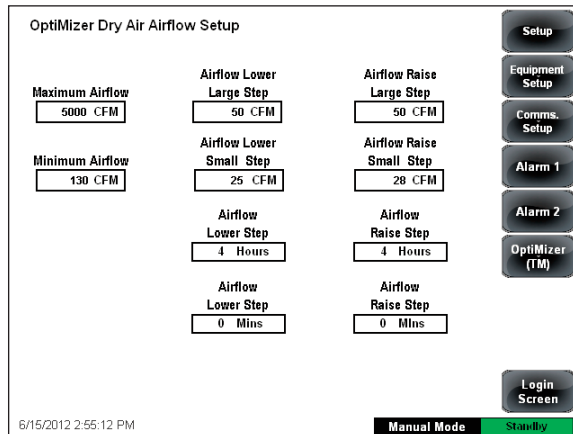

OptiMizer™ Dry Air Airflow Setup Screen

The OptiMizer™ Dry Air Airflow Setup screen shows all of the setpoints for the airflow when the OptiMizer™ function is running. These setpoints are used during the Tune Up/Down mode of operation. The minimum and maximum airflow setpoints are based on the dryer and hopper models. Typically these are the only values that may require adjustment. Adjustment of the minimum and maximum airflow setpoints is described later in this manual.

(continued)

Using the OptiMizer™ (continued)

Dry Air Min Airflow	Minimum Airflow	Primary Hopper Min Airflow
W600 Dryer 120 CFM	130 CFM	38" Hopper 130 CFM
W800 Dryer 160 CFM	60 %	44" Hopper 160 CFM
W1000 Dryer 200 CFM		54" Hopper 250 CFM
W1600 Dryer 320 CFM		64" Hopper 320 CFM
W2400 Dryer 360 CFM		74" Hopper 450 CFM
W3200 Dryer 560 CFM		100" Hopper 825 CFM
W5000 Dryer 640 CFM		

OptiMizer™ Minimum Airflow Setup Screen

This OptiMizer™ Airflow Setup screen displays Minimum Airflow values for each of the various dryer and hopper models. In any given system, the **HIGHEST** Minimum Airflow value for the system equipment should be used when running the system or setting up the OptiMizer™.

For example, if the system consists of W2400 Dryer and a 74" Hopper, the minimum airflows associated with those pieces of equipment are 360 CFM and 450 CFM respectively. Therefore in this instance, the Minimum Airflow value of the hopper or 450 CFM should be used for the system setting. This value should be entered in the Minimum Airflow setpoint fields on the previously shown screens. The 'Defaults' button on this screen is used to return the minimum and maximum airflow setpoint values shown for the various models of dryers and hoppers back to the factory default settings.

Using the OptiMizer™ (continued)

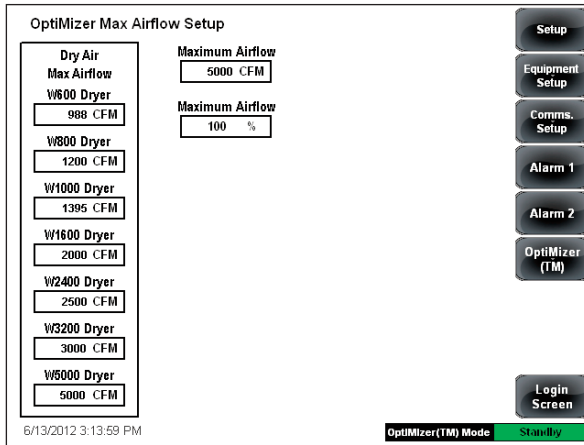

OptiMizer™ Maximum Airflow Setup Screen

This OptiMizer™ Airflow Setup screen displays Maximum Airflow values for each of the various dryer models. These maximum airflow settings shown on this screen are for display and information only.

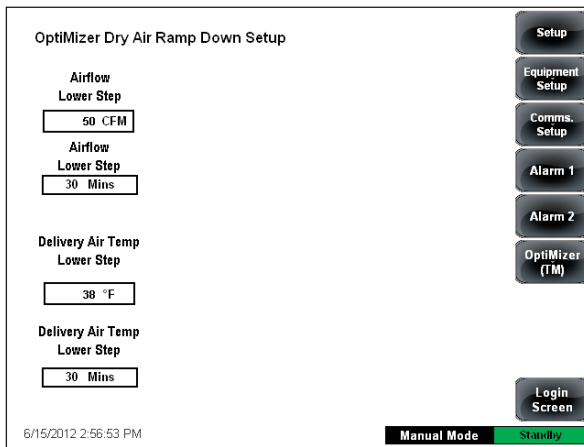

OptiMizer™ Dry Air Ramp Down Setup Screen

The OptiMizer™ Dry Air Ramp Down Setup screen is used to adjust the setpoints used in the Dynamic Ramp sequence. These setpoints are the actual steps and timing used when an Optimized recipe completes the Dynamic Delay and begins the Dynamic Ramp Down sequence.

(continued)

Using the OptiMizer™ (continued)

OptiMizer Quick Up Setup

Delivery Air Temp
Raise Quick Step
10 °F

Delivery Air Temp
Raise Quick Step
2 Hours

Delivery Air Temp
Raise Quick Step
0 Mins

Setup
Equipment Setup
Comms. Setup
Alarm 1
Alarm 2
OptiMizer (TM)
Login Screen

6/13/2012 3:15:29 PM

OptiMizer(TM) Mode Standby

OptiMizer™ Quick Up Setup Screen

The OptiMizer™ Quick Up Setup screen is used to enter the setpoints for the Quick Up sequence. This sequence is enabled after material flow has been detected. The Quick Up is used when the material temperature and the temperature profile in the hopper falls below the setpoints. A Quick up is designed to provide immediate heat to the system. This is used when the control predicts that a disruption from norm has occurred and it may cause the material conditions to be disrupted at the throat. This is a safety to prevent material from being delivered to the machine throat at lower than desired conditions.

Using the OptiMizer™ (continued)

The screenshot displays the OptiMizer™ Status screen with the following data and controls:

- OptiMizer Status:** Shows the current mode as **Steady**.
- Predry:** Initial Delay Timer (Typically 90 Minutes) at 0:00. Predry Timer at 0:00:00.
- Ramp Down:** Dry Air Flow and Dry Air Temp both at 0:00:00.
- Optimizer Delay:** Hrs. Mins. Sec. at 0:00:00.
- Dynamic Tune:** Step counts for Dry Air Temp and Dry Air Flow are 0:00:00. Step Time SP is 2:00.
- Tune Up:** Dry Air Temp and Dry Air Flow both at 0:00:00.
- Tune Down:** Dry Air Flow and Dry Air Temp both at 0:00:00.
- Quick Up:** Dry Air Temp at 0:00:00.
- Temperature and Airflow Readings:**
 - Delivery Air Temp: T6 (126°F), T5 (133°F), T4 (147°F), T3 (344°F), T2 (347°F), T1 (351°F).
 - Airflow: 0 CFM.
 - Material Temp Target: 340°F.
- Controls:** Setup, Equipment Setup, Comma. Setup, Alarm 1, Alarm 2, OptiMizer (TM), Counter Reset, Login Screen.
- Footer:** 6/13/2012 3:20:15 PM, OptiMizer(TM) Mode: Steady.

OptiMizer™ Status Screen

The OptiMizer™ Status screen is used to monitor the overall status of the OptiMizer™ sequence. This screen will show what mode the OptiMizer™ sequence is in and how much time is remaining in each step. The screen also displays the important system temperature and airflow readings

Using the OptiMizer™ (continued)

Recipe Setup and Management

The key to the OptiMizer™ operation is the recipe. Creating and managing the recipes are the most important part of having the most efficient OptiMizer™ operation. Shown below is the recipe management screen from the control panel HMI. This screen allows an operator with the appropriate user rights to create, upload, download and manage the OptiMizer™ recipes. The recipe management functions are also described below the screen graphic.

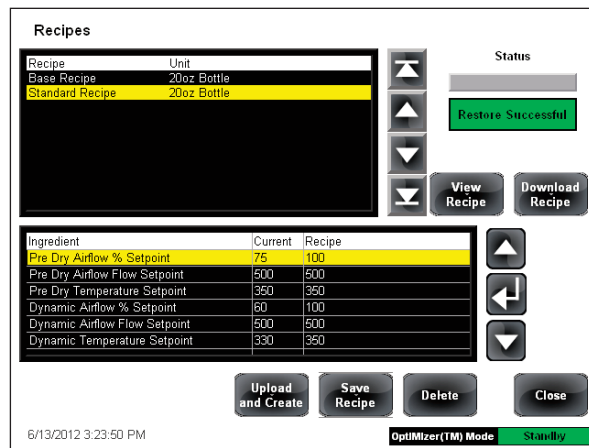

Recipes Configuration Screen

The top display section of this screen lists all of the saved recipes. These recipes can be viewed and downloaded to the OptiMizer™ control using the buttons to the right of the recipe list display. The following is a description of the buttons associated with the top recipe display.



Moves the highlight bar to the first recipe name in the list.



Scrolls the highlight bar up one recipe name.



Scrolls the highlight bar down one recipe name.

Using the OptiMizer™ (continued)



Moves the highlight bar to the last recipe name in the list.



When pressed the currently highlighted recipe parameters will be displayed in the bottom recipe display on the screen.



Downloads the setpoints from the currently highlighted recipe in the top recipe display to the controller.

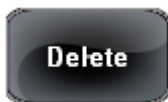

When pressed, the currently highlighted recipe will be deleted from the HMI.

The bottom display section of this screen shows the setpoints of the currently selected recipe (after the 'View Recipe' button has been pushed) and the setpoints currently stored in the controller. The following is a description of the buttons associated with the bottom recipe setpoints display.



Moves the highlight bar up one setpoint name in the list.



Starts the edit function for the highlighted setpoint.



Moves the highlight bar down one setpoint name in the list.

Using the OptiMizer™ (continued)



When pressed, the setpoints currently stored in the controller will be uploaded to the HMI and displayed in the bottom display of the screen in the 'Current' column. Using these setpoints, a new recipe is created. After the button has been pressed, the operator will be asked to name the recipe. The operator can then change any of the setpoints and save the new recipe.



When pressed, the newly created or updated recipe is saved.



Downloads the setpoints from the currently highlighted recipe in the top recipe display to the controller.

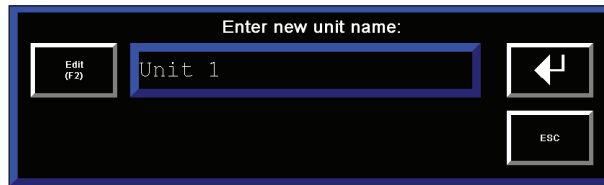

New Recipe Name Entry Popup

The New Recipe Name popup will be displayed when the 'Upload and Create' button is pressed. In this popup, the word 'unit' is used instead of 'recipe'; that is the default term from the HMI Panel software and cannot be changed by Conair. Press the 'Edit (F2)' button and enter the name of the new recipe. After the name has been entered, press the enter button and the name will be saved. Then after the name has been saved, make any changes necessary to the recipe and press the 'Save Recipe' button. This will save the recipe in the HMI for future use.

Using the OptiMizer™ (continued)

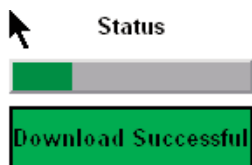

Shows the status of the current recipe function. The download, upload, create, restore, save, and delete functions show a status in this box that shows progress, completion, and errors. After a function button has been selected, a delay occurs before the system will update the status.

The bottom display section of this screen shows the setpoints of the currently selected recipe (after the 'View Recipe' button has been pushed) and the setpoints currently stored in the controller. The following is a description of the buttons associated with the bottom recipe setpoints display.

The following table shows all of the setpoints and settings in a typical recipe. Each setting and setpoint will have a description, minimum, and maximum range.

Name	Min	Max	Description
Pre-dry Airflow (%)	20	100	Airflow, when in Pre-dry, used if the Variable Speed Drive providing the airflow is in Fixed Frequency (manual) mode.
Pre-dry Airflow Flow (CFM)	200	5000	Airflow, when in Pre-dry, used if the Variable Speed Drive providing the airflow is in PID Control (automatic) mode. This is the recommended mode of control for the airflow when using OptiMizer™.
Pre-dry Temperature (°F)	80	375	Air delivery temperature setpoint when in Pre-dry.
Dynamic Airflow (%)	20	100	Airflow setpoint for the Optimized recipe in Ramp Down mode, used if the Variable Speed Drive providing the airflow is in Fixed Frequency (manual) mode.
Dynamic Airflow Flow (CFM)	200	5000	Airflow setpoint for the Optimized recipe in Ramp Down mode, used if the Variable Speed Drive providing the airflow is in PID Control (automatic) mode. This is the recommended mode of control for the airflow when using OptiMizer™.
Dynamic Temperature (°F)	80	375	Air delivery temperature setpoint for the Optimized recipe in Ramp Down mode.

(continued)

Using the OptiMizer™ (continued)

Name	Min	Max	Description
Cool down Temperature (°F)	24	375	Cool down temperature is used when the temperature method of Cool Down is selected. This is also the temperature the material will be cooled to when the Auto Cool down is enabled..
Material Target Temperature (°F)	24	400	Material Target Temperature setpoint as measured at the IMM or extruder machine throat by the Conair Material Temperature RTD.
Material Maximum Temperature (°F)	24	400	Material Maximum Temperature should be set to the highest temperature the material can withstand as determined by the material manufacturer.
Optimized	0 (No)	1 (Yes)	Sets the recipe as non-Optimized or Optimized in the controller.

Recipe Creation

There are a few guidelines when creating a recipe for the first time. Using the 'Upload and Create' button on the Recipe screen, the operator can upload the current recipe values from the controller (even if a recipe has never been downloaded) and start a new recipe. (It is recommended that the operator download the 'Standard' recipe first then press the 'Upload and Create' button. This ensures that the new recipe starts with valid values.) Then using the recipe setpoint navigation buttons as described above, the operator can make changes to the recipe setpoints. Entering values for the Dynamic setpoints is not required; however, it is suggested to set them to the same values as their similar Pre-dry setpoints. In a non-Optimized recipe, the Dynamic setpoints will not be used by the controller. Below are guidelines on how to set up the Pre-dry, Cool Down, and Material Temperature setpoints for a new non-Optimized recipe.

- **Pre-dry Airflow (%)** – This airflow setpoint is used when the Process Air VSD (Variable Speed Drive) is in Fixed Frequency (manual) mode. Fixed Frequency means that the VSD will keep a certain output % of total speed regardless of the actual airflow in the system. For an initial recipe 90% - 100% is the recommended starting range.

Using the OptiMizer™ (continued)

- **Pre-dry Airflow Flow (CFM)** – This airflow setpoint is used when the Process Air VSD is in the PID Control (automatic) mode. PID control means that the controller adjusts the actual VSD output percentage in order to keep the airflow at the specific CFM recipe setpoint. The controller will take the output % of the VSD to the maximum or minimum range to achieve the setpoint. However, if a setpoint is used that can not be achieved, the system will stay at the maximum or minimum range during Pre-dry operation. The recommended starting point for this setpoint is 90% of the maximum airflow as shown on the ‘OptiMizer™ Max Airflow Setup’ HMI screen detailed above.
- **Pre-dry Temperature (°F)** – This temperature setpoint is for the process delivery air for the dryer. The setpoint for this temperature needs to be set above the desired Material Target Temperature and at or below the manufacturer’s temperature maximum limit for the resin being used or 375 °F (maximum recipe setpoint) whichever is lower. The recommended setpoint for this temperature is the midpoint between the Material Temperature Target setpoint and the manufacturer’s temperature maximum or recipe limit.
- **Cool Down Temperature (°F)** – Cool Down temperature is used when the temperature method of Cool Down is selected. The user will select a DMII temperature probe (T1-T6) to use for Cool Down. When the system Cool Down is activated or the Auto Cool Down is enabled and the system is shut-down and the temperature of that probe falls below the Cool Down temperature setpoint, the process blower shuts down and the regeneration system begins its shutdown sequence.
- **Material Target Temperature (°F)** – This temperature setpoint is for the material at the IMM or extruder machine throat as measured by the Conair Material Temperature RTD. The main goal of the OptiMizer™ operation is to keep the material temperature at this setpoint using the least amount of energy as possible. This temperature is usually determined by the material and extruding or molding machinery being used.
- **Material Maximum Temperature (°F)** – This temperature setpoint is for the material at the IMM or extruder machine throat as measured by the Conair Material Temperature RTD. The OptiMizer™ uses this value for the upper limit of the Material Temperature setpoint to ensure that the material temperature does not exceed the temperature rating of the material.
- **Optimized** – For an initial or new recipe, this should be set to 0 (OFF). This means that the recipe is a non-Optimized recipe and the system will take the necessary steps to achieve an Optimized state. When that state has been achieved and the system displays the Optimized message, the Dynamic setpoints in the recipe can be changed and this setting can be changed to 1 (ON).

(continued)

Using the OptiMizer™ (continued)

Example Recipe for a W1000 System

The following table shows an example of an Optimized recipe for a W1000 Dryer with a 64” hopper.



CAUTION: This is an example recipe only, in order to create an Optimized recipe for any system, the steps outlined in this manual must be followed.

Name	Recipe Setpoint
Pre-dry Airflow (%)	90
Pre-dry Airflow Flow (CFM)	500
Pre-dry Temperature (°F)	350
Dynamic Airflow (%)	75
Dynamic Airflow Flow (CFM)	500
Dynamic Temperature (°F)	350
Cool Down Temperature (°F)	200
Material Target Temperature (°F)	330
Material Maximum Temperature (°F)	375
Optimized	1 (Yes)

Starting OptiMizer™ on Already Running System

The OptiMizer™ function can be started on a system that is currently running. An operator can download an Optimized or non-Optimized recipe from the Recipe screen. Depending on the current state of the system temperatures, material usage, and Optimized status of the recipe, the system will react in several ways when the OptiMizer™ is enabled.

- 1** System Running, Temperatures below setpoints, no material usage:
In this case, the system will go through the Pre-dry steps and through the OptiMizer™ functions as described above. This is basically the same as the cold start scenario described above.

Using the OptiMizer™ (continued)

- 2** System Running, Temperatures below setpoints, material usage:
In this case, the system will skip over all of the Pre-dry steps and go into the Dynamic Delay step and through the OptiMizer™ functions as described above. Since the temperatures were not above the setpoints, using the OptiMizer™ in this fashion will probably result in poor performance and is not recommended.
- 3** System Running, Temperatures above setpoints, no material usage:
The system will skip over the Pre-dry steps and go into the Dynamic Delay step immediately as the Machine Run signal is satisfied. Then the system proceeds through the OptiMizer™ function as described above.
- 4** System Running, Temperatures above setpoints, material usage:
The system will skip over the Pre-dry steps and go into the Dynamic Delay step and proceed through the OptiMizer™ function as described above.

Maintenance

Preventative maintenance checklist	5-2
Inspecting hoses, piping and gaskets	5-8
Cleaning the CH hopper	5-9
Maintaining the Dwyer 641 air velocity transmitter	5-10
Cleaning the combustion filter of the GasTrac	5-11
Cleaning the electrical enclosure filter of the GasTrac.	5-12
Replacing the spark igniter of the GasTrac. .	5-13
Cleaning the ultraviolet flame detector of the GasTrac.	5-15
Cleaning the process filter	5-17
Cleaning the regeneration filter	5-18
Cleaning the aftercooler/intercooler coils . .	5-19
Cleaning the volatile trap on the demister (W600-1000)	5-21
Cleaning the volatile trap on the demister (W1600-5000)	5-22
Cleaning the precooler coils	5-23
Replacing the regeneration heater (W600-1000)	5-24
(W1600-2400)	5-26
(W3200-5000)	5-28
Checking the dew point	5-30
Cleaning the dust collector (optional)	5-32
Cleaning the cyclone separator (optional) . .	5-35

Preventative Maintenance Checklist



NOTE: For detailed maintenance instructions for the components of the EnergySmart Dryer System, refer to the individual component manuals supplied with the system.

Routine maintenance will ensure optimum operation and performance of the EnergySmart™ Dryer System and its components. Conair recommends the following maintenance schedule and tasks.

- **Whenever changing materials.**

- Drain and clean the CH Hopper.**
- Clean the optional receiver(s) that fills the hopper** (see the appropriate receiver user guide.)
- Clean the optional receivers' filter(s).** If you are running a dusty material or regrind you may need to check and clean the screen filter more often. If the material flow is erratic or sluggish, check the filter.
- Change the GasTrac's setpoint. (If necessary)**
- Change the HTC's setpoint. (If necessary)**
- Change the Drying Monitor's setpoint entries on the control.** Verify that the temperature settings are correct for the new material.
- Inspect the Drying Monitor probe and mounting assembly.** If the probe is damaged, replace it. If vibration has loosened the probe's mounting hardware, tighten as necessary.
- Empty and clean the optional cyclone separator's collecting tank.**
- Empty and clean the optional dust collector's dust filter.**

Preventative Maintenance Checklist (continued)

• Weekly, or as often as needed.

- Inspect all hoses/piping and connections.** Check for damage, kinks, or loose hose clamps. Replace any hoses or pipes that show signs of damage or wear. Reposition and tighten loose hose clamps or pipe fittings.
- Clean the optional receivers' filter(s).** If you are running a dusty material or regrind you may need to check and clean the screen filter more often. If the material flow is erratic or sluggish, check the filter.
- Drain the compressed air filter trap (if equipped).** Depending on your compressed air system, you may see moisture or oil in the compressed air filter trap. Open the petcock on the bottom of the trap to drain. If you see oil, Conair recommends installing a coalescing type filter ahead of the standard moisture removing filter.
- Check and clean the pump inlet filter.** An inlet filter has been provided to protect the pump from solid material that can enter and damage the pump impellers. Material can enter the vacuum line if a loader filter is improperly installed or if it has a hole in it. Replace the pump inlet filter if it is torn or worn.
- Check all V/belts.** The V/belts have a tendency to stretch, so an adjustable motor base is provided. Keep belts tight to prevent slippage and wear. Do not use belt dressings.
- Clean the GasTrac's combustion air filter (option).** You may need to clean the filter more often than weekly. Frequency depends on the amount of dust in the installation's ambient air.
- Clean the GasTrac's electrical enclosure filter (option).** You may need to clean the filter more often than weekly. Frequency depends on the amount of dust in the installation's ambient air.
- Inspect the GasTrac's inlet and outlet hoses or piping (option).** Tighten loose hose clamps. Replace the hose or pipe if worn or damaged. Reposition and tighten loose hose clamps or pipe fittings.



NOTE: For detailed maintenance instructions for the components of the EnergySmart Dryer System, refer to the individual component manuals supplied with the system.

Preventative Maintenance Checklist (continued)



NOTE: For detailed maintenance instructions for the components of the EnergySmart Dryer System, refer to the individual component manuals supplied with the system.

- **Weekly, or as often as needed.**

- Inspect the HTC's inlet and outlet hoses or piping.** Tighten loose hose clamps. Replace the hose or pipe if worn or damaged. Reposition and tighten loose hose clamps or pipe fittings.
- Clean the dryer's process and regeneration filters.** You may need to clean the filters more often than weekly. Frequency depends on the amount of dust in the installation's ambient air.
- Inspect dryer's hoses, piping and connections.** Check for damage, kinks or loose hose clamps. Replace any hoses or pipes that show signs of damage or wear. Reposition and tighten loose hose clamps and/or pipe fittings.
- Drain and clean the dryer's demister.**

- **Monthly, or as often as needed.**

- Inspect all hoses, piping and connections.** Check for damage, kinks, or loose hose clamps. Replace any hoses or pipes that show signs of damage or wear. Reposition and tighten loose hose clamps and/or pipe fittings.
- Change the vacuum pump's oil.** The vacuum pump has been filled with the proper oil and tested by Conair before shipment. Even so, this oil should be changed periodically. Use SAE 40 regular or an equivalent oil.
- Check the vacuum pump's motor bearings and grease, if necessary.** The motor is equipped with double-shielded ball bearings having sufficient grease to last indefinitely under normal service. But if the motor is used constantly in dirty, wet or corrosive atmospheres, you should add 1/4 oz. of grease per bearing every three months. Use a quality, rust-inhibiting, polyure-based grease such as Chevron SRI. Refer to the motor manual for additional instructions.

Preventative Maintenance Checklist (continued)

- **Monthly, or as often as needed.**

- Inspect GasTrac's air hoses, piping and connections.** Check for damage, kinks or loose hose clamps. Replace any hoses or pipes that show signs of damage or wear. Reposition and tighten loose hose clamps or pipe fittings.
- Inspect and test the GasTrac's safety controls.** Fuel safety shutoff valves, combustion safeguards and temperature and pressure switches should be inspected and tested by trained personnel.
- Inspect the GasTrac's burner sight glass.** Clean the sight glass, if needed. Replace the sight glass if you see cracks or any other defect.
- Inspect the HTC's main power wires, heater wires and conduit and RTD probe wires for damage and wear.** Replace any damaged or worn wire or conduit.
- Check for any damage to the HTC control panel.** Replace if damaged.
- Check for damage to the HTC's heater box.** Replace if damaged.
- Clean dirt from exterior surfaces of the HTC with a cloth dampened with water.**
- Clean the dryer's aftercooler/intercooler coils.** You may need to clean the coils more often than monthly. Frequency will depend on the type and volume of material that is to be processed.
- Inspect Drying Monitor's cables and cords for damage or wear.** Replace any cable or power cord that is worn.
- Inspect Drying Monitor's cable connections.** Check for damage or loose connections. Tighten the connections or replace the damaged connectors.
- Empty and clean the optional cyclone separator's collecting tank.**
- Empty and clean the optional dust collector's dust filter.**
- Clean and inspect the velocity probe.**



NOTE: For detailed maintenance instructions for the components of the EnergySmart Dryer System, refer to the individual component manuals supplied with the system.

Preventative Maintenance Checklist (continued)



NOTE: For detailed maintenance instructions for the components of the EnergySmart Dryer System, refer to the individual component manuals supplied with the system.

- **Every six months.**

- Inspect all gaskets for damage or wear.** Damaged gaskets can allow moisture to seep into the closed-loop drying system. Replace any gasket that is torn or cracked.
- Inspect all piping, wiring and electrical connections.** Check for leaks, corrosion and loose connections. Replace any component that shows signs of damage or wear. Tighten loose connections.
- Inspect all receiver wiring connections.** Power and cable connections between the loading control and optional receiver may become loose or wires may become worn. Tighten any loose connections and replace any wire or cable that has become worn or damaged.
- Inspect the receiver(s) installation.** Check installed mounting hardware to make sure that the installation is secure.
- Check the vacuum pump's relief valve for proper operation.** The vacuum relief valve is designed to protect the pump from damage if the conveying line becomes clogged or obstructed.
- Inspect the GasTrac's metal-ceramic burner.** While the unit is fired, look through the sight glass at the burner. The burner surface should be glowing orange with an even flame. Blue flames, flames projecting from the burner surface, or cracks or dark spots on the burner surface indicate damage, replace the burner as necessary.
- Empty and clean the optional cyclone separator's collecting tank.**
- Empty and clean the optional dust collector's dust filter.**

Preventative Maintenance Checklist (continued)

- **Annually.**

- Inspect all gaskets for damage or wear.** Damaged gaskets can allow moisture to seep into the closed-loop drying system. Replace any gasket that is torn or cracked.
- Replace the GasTrac's spark igniter.** To assure optimum performance, you should replace the spark igniter once a year.
- Clean the GasTrac's ultraviolet flame detector lens.** Use alcohol and a soft cloth.
- Empty and clean the optional cyclone separator's collecting tank.**
- Empty and clean the optional dust collector's dust filter.**



NOTE: For detailed maintenance instructions for the components of the EnergySmart Dryer System, refer to the individual component manuals supplied with the system.

Inspecting Hoses, Piping and Gaskets

Loose or damaged hoses, piping and gaskets can allow moisture to seep into the closed-looped drying circuits.

To inspect:

- 1 Follow the hose and/or piping routing of all hoses and pipes within the EnergySmart Dryer System.** Inspect all hoses, clamps, fittings and gaskets.
- 2 Tighten any loose hose clamps or pipe fittings.**
- 3 Replace worn or damaged hoses, pipes and gaskets.**

Cleaning the CH Hopper



CAUTION: Hot surfaces. Always protect yourself from hot surfaces inside and outside the dryer and drying hopper.

The hopper, spreader cone, and discharge assembly should be cleaned thoroughly between material changes to prevent resin contamination.

- 1 Close the hopper slide gate.**
- 2 Place a container beneath the hopper's drain port** to catch the material.
- 3 Open the drain port** (if equipped) and allow the material to drain.
- 4 Open the hopper door and wipe out the inside** of the hopper.
- 5 Clean the return air screen** at the return air outlet of the hopper.



CAUTION: Wear eye protection. If you use compressed air to clean the equipment, **you must wear eye protection** and observe all OSHA and other safety regulations pertaining to the use of compressed air.

- 6 Remove the container from beneath the hopper and replace the drain port cover** before filling the hopper with material.

Maintaining the Dwyer 641 Air Velocity Transmitter

The AVT probe will collect dirt and dust from the air stream. It needs to be cleaned at least once a month. To clean the probe:

- 1** Switch the blower to “Manual” on the Dehumidifying Dryer Screen (Screen 4) and input the proper percentage setpoint to maintain the proper air flow, before you remove the probe from the pipe.
- 2** Mark the depth that the probe is inserted into the pipe, for reinstallation.
- 3** Observe the percentage of drive speed on the Dehumidifying Dryer Screen (Screen 4) before you switch to manual. Once you switch to manual input, this number turns into the setpoint %.

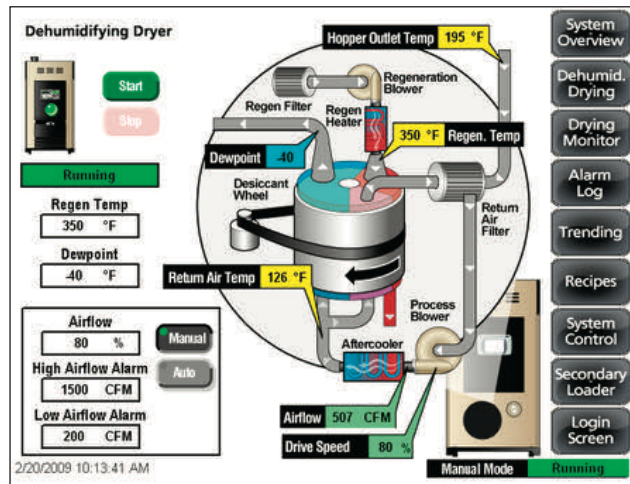

- 4** Remove the AVT probe from the pipe and clean it with a Q-tip and denatured alcohol. Use care when cleaning so you do not damage the measuring element in the probe.
- 5** Reinstall the air velocity probe back into the pipe. Make sure it is installed at the same depth and air flow direction. (Note flow arrow.)
- 6** Switch the blower to “Auto” on the Dehumidifying Dryer Screen (Screen 4) if desired.

Cleaning the Combustion Filter of the GasTrac

You must clean the combustion air intake filter periodically. A clogged filter reduces air flow through the combustion circuit, which reduces burner efficiency and heat output.

To clean the filter:

1 Stop the GasTrac. Press the red “STOP” button, then press the rocker switch to “OFF”.

2 Disconnect and lock out the main power.

3 Remove the filter shroud. Remove the wing nut and washer that holds the shroud in place. Lift the shroud up and off.

4 Remove the filter. Remove the wing nut and washer that holds the filter in place. Lift the filter up and off.

5 Clean the filter. Vacuum debris from the filter using vacuum.



CAUTION: Wear eye protection. If you use compressed air to clean the equipment, **you must wear eye protection** and observe all OSHA and other safety regulations pertaining to the use of compressed air.

6 Reassemble. Repeat Steps 3 and 4 in reverse order to replace the filter.



Rocker Switch

Stop Button

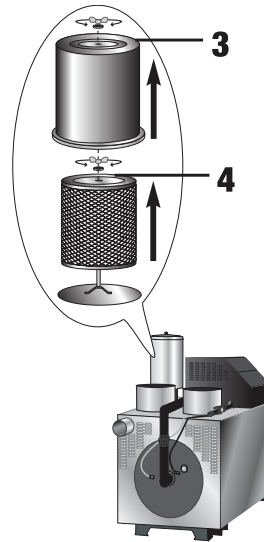
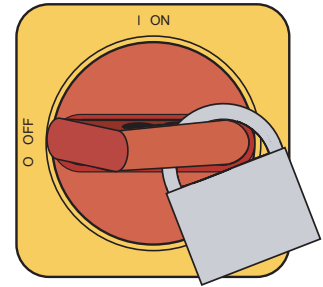

Replacement filters are available from Conair.

Contact Conair Parts
(800) 458 1960
From outside of the
United States, call:
(814) 437 6861

Cleaning the Electrical Enclosure Filter of the GasTrac

Periodically, you should clean the filters covering the cooling fan inlet and outlet on the GasTrac's electrical enclosure.

To clean the filter:

Replacement filters are available from Conair.

Contact Conair Parts
(800) 458 1960
From outside of the
United States, call:
(814) 437 6861

1 Remove the the thumb screws and filters.



2 Clean the filters. Use vacuum to remove loose debris. Wash the filters in warm, soapy water, then rinse and air dry. Replace torn or worn filters.



CAUTION: Wear eye protection. If you use compressed air to clean the equipment, **you must wear eye protection** and observe all OSHA and other safety regulations pertaining to the use of compressed air.

3 Replace the filter, filter cap and thumb screws.



Replacing the Spark Igniter of the GasTrac

The spark igniter should be replaced at least once a year to assure trouble-free operation. You should replace the igniter before the annual period, if you find:

- The spark gap is less than 0.125 in. {3.2 mm}. The gap should be between 0.07 and 0.09 in. {1.8 and 2.3 mm}.
- The igniter insulation is cracked
- The spark electrodes are warped or taper to a needle-like shape.

Do not operate the GasTrac with a worn or damaged spark igniter. A badly burned or warped igniter can cause burner ignition failure.

- 1 Stop the GasTrac.** Press the red “STOP” button, then press the rocker switch to “OFF.”
- 2 Disconnect and lock out the main power.**
- 3 Remove the igniter wire.** Pull the wire boot, not the wire, away from the spark igniter. If the wire or its boot is cracked, it should be replaced.



IMPORTANT: When removing or inserting the spark igniter, do not allow the igniter electrode or grounding rod to touch the burner. You could damage the burner surface.

- 4 Remove the spark igniter.** Use an appropriately-sized spark plug socket and ratchet to loosen the igniter. Pull the igniter straight out of the GasTrac. Do not allow the spark igniter to touch the burner surface.

- **TIP:** Before removing the spark igniter for inspection, use a felt tip marker to mark the position of the igniter in its threaded hole. By indexing the position, you will be able to return the igniter to the correct position after inspection. The igniter must be installed so that the ground rod is 180° away from the burner surface.

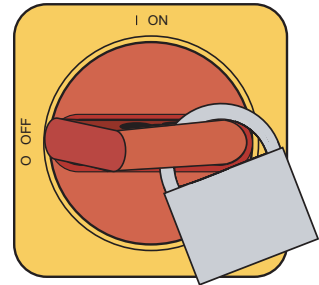

Replacement igniters are available from Conair.

Contact Conair Parts
(800) 458 1960
From outside of the
United States, call:
(814) 437 6861



Rocker Switch

Stop Button

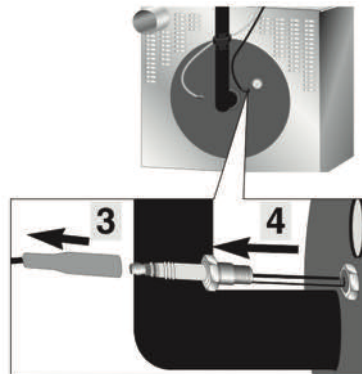

CAUTION: Hot surfaces. Always protect yourself from hot surfaces.



(continued)

Maintenance | 5-13

Replacing the Spark Igniter of the GasTrac (continued)

Replacement igniters are available from Conair.

Contact Conair Parts
(800) 458 1960
From outside of the
United States, call:
(814) 437 6861

- 5 Mark the position of the grounding rod on the new spark igniter, using a felt tip marker.** This index mark must end up 180° away from the burner surface when the spark igniter is inserted and tightened. The electrode should be closest to the burner surface.

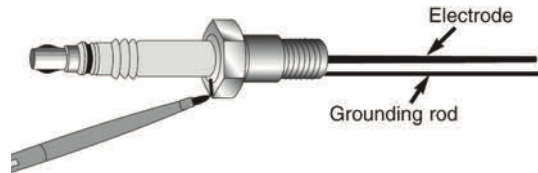

- 6 Coat the threads of the igniter with a high-temperature conductive anti-seize compound.**
- 7 Carefully insert the igniter into the GasTrac.** Insert the igniter straight into the threaded fitting. Do not bend the electrode, and do not allow the spark igniter to touch the burner surface.

- 8 Screw the igniter into the threaded fitting.** Tighten by hand first. Then use a socket and ratchet to tighten the igniter one turn or a partial turn until the index mark on the igniter is 180° from the burner surface.

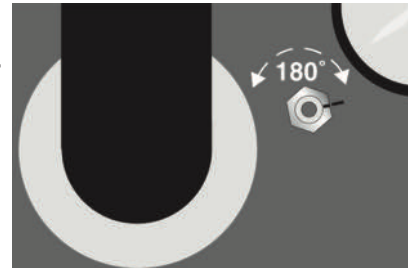

IMPORTANT: Over tightening of the spark igniter may cause damage to the porcelain insulator.

- 9 Push the boot and wire onto the spark igniter,** until you feel the boot snap into place.

Cleaning the Ultraviolet Flame Detector of the GasTrac

A dirty ultraviolet flame detector may fail to recognize burner ignition, which will cause the GasTrac to alarm and shut down automatically.

To clean the ultraviolet flame detector:

- 1 Stop the GasTrac.** Press the red “STOP” button, then press the rocker switch to “OFF.”

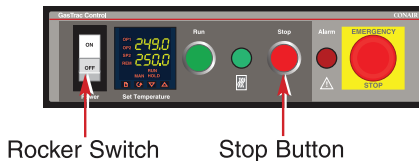

- 2 Disconnect and lock out the main power.**

- 3 Remove the flame detector.** Loosen the mounting nut while holding the flame detector, then pull the detector away from the viewing hole.

- 4 Clean the viewing hole lens.** Use a soft cloth or cotton swab moistened with alcohol.

- 5 Replace the flame detector.** Align the detector over the viewing hole, and thread the silver mounting nut onto the coupling. Hand tighten first. Then using an appropriately-sized wrench to tighten the nut an additional quarter turn.

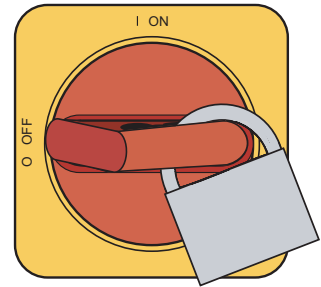
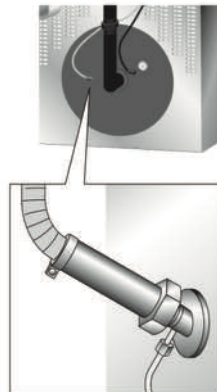

Warning: Hot surfaces.
Allow the GasTrac to cool before removing the burner guard to perform maintenance.

Replacement flame detectors are available from Conair.

Contact Conair Parts
(800) 458 1960
From outside of the
United States, call:
(814) 437 6861

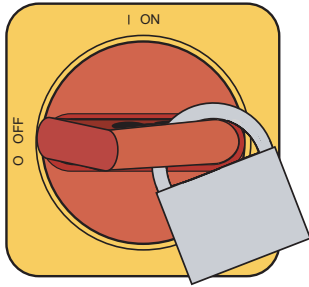

Warning: Hot surfaces.

Allow the GasTrac to cool before removing the burner guard to perform maintenance.

Replacement sight glasses are available from Conair.

Contact Conair Parts
(800) 458 1960
From outside of the
United States, call:
(814) 437 6861

Cleaning the Burner Sight Glass of the GasTrac

A dirty sight glass prohibits inspection or viewing of the metal-ceramic burner during operation.

To clean the sight glass:

- 1 Stop the GasTrac.** Press the red “STOP” button, then press the rocker switch to “OFF.”
- 2 Disconnect and lock out the main power.**
- 3 Remove the screws on the sight glass bracket.**
- 4 Clean the sight glass.** Use a clean soft cloth or cotton swab moistened with alcohol.
- 5 Coat the screw threads with a high-temperature antiseize compound.**
- 6 Replace the sight glass.** Tighten the screws in the bracket to hold the glass in place.



Rocker Switch

Stop Button

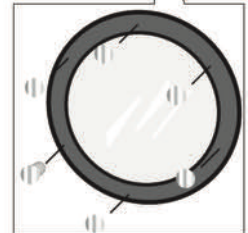
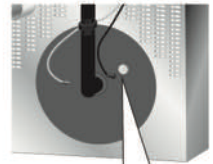

Cleaning the Process Filter

Clogged filters reduce air flow and dryer efficiency. Cleaning frequency depends on how much material you process and how dusty or full of fines it is.

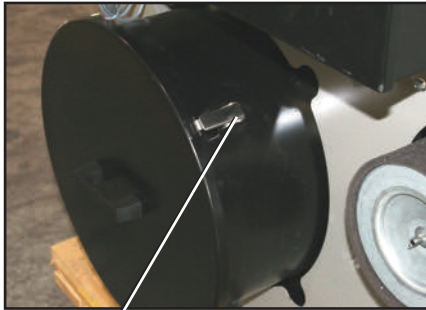

Process Filter Cap Latch (4)

- 1 Remove the four (4) filter cap cover latches**, then pull the filter cap off.
- 2 Remove the filter wing nut**, then remove the filter.
- 3 Clean the filter by laying it on its side and gently tapping it on the floor.** Replace damaged, worn, or clogged filters.
- 4 Reverse the procedure to reinstall the process filter.** Ensure that the gasket on filter cap is in place and in good condition.



CAUTION: Wear eye protection. If you use compressed air to clean the equipment, **you must wear eye protection** and observe all OSHA and other safety regulations pertaining to the use of compressed air.

- TIP:** If gasket on the process filter cap becomes loose or detached from the filter cap, resecure with high temperature silicone adhesive.



CAUTION: Hot surfaces.

Always protect yourself from hot surfaces inside and outside the dryer and drying hopper.

Replacement process filters are available from Conair.

Contact Conair Parts
(800) 458 1960
From outside of the
United States, call:
(814) 437 6861

Cleaning the Regeneration Filter



CAUTION: Hot surfaces.

Always protect yourself from hot surfaces inside and outside the dryer and drying hopper.

Replacement regeneration filters are available from Conair.

Contact Conair Parts
(800) 458 1960
From outside of the
United States, call:
(814) 437 6861

Clogged filters reduce air flow and dryer efficiency. Cleaning frequency depends on the condition of your dryer's ambient air.



- 1 Remove the filter wing nut**, then remove the filter.
- 2 Remove outer filter** and clean it with soapy water. Let air dry.
- 3 Clean the filter by laying it on its side and gently tapping it on** Replace damaged, worn, or clogged filters.
- 4 Reverse the procedure to reinstall the regeneration filter.**



CAUTION: Wear eye protection. If you use compressed air to clean the equipment, **you must wear eye protection** and observe all OSHA and other safety regulations pertaining to the use of compressed air.

Cleaning the Aftercooler/ Intercooler Coils

You need to clean the aftercooler/intercooler coils to keep them working efficiently. Cleaning frequency depends on the type and amount of material you process.

1 Stop the dryer and lockout the main power. 

2 Turn off the water flow to the water supply line. Disconnect supply and return lines.

 **NOTE:** If an optional flow control was added with the aftercooler/intercooler, remove the compression fitting from the aftercooler/intercooler inlet. Loosen the fitting on the flow control, then swing the copper water supply tube out and away from the aftercooler/intercooler inlet.

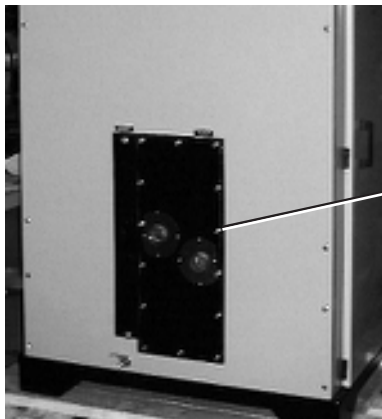
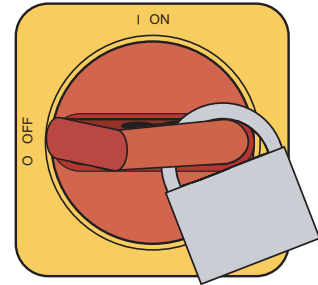

W600 - 1000
Models

W1600 - 5000
Models



3 Remove the bolts securing the aftercooler/intercooler cover. Remove the cover.

4 Remove the aftercooler/intercooler by pulling it out of the aftercooler/intercooler housing.

Cleaning the Aftercooler/ Intercooler Coils (continued)

Replacement gaskets are available from Conair.

Contact Conair Parts
(800) 458 1960
From outside of the
United States, call:
(814) 437 6861

5 Clean the assembly using a mild soap and water. Let the assembly dry thoroughly before installation.



NOTE: In cases of heavy volatiles, steam cleaning or the use of solvents, such as acetone, may be necessary. Be sure to test a small area with the solvent you have selected to be sure there is no adverse reaction.

6 Inspect the condition of the gasket. If it is damaged, replace the gasket.

7 Reassemble by repeating the steps in reverse order.

8 Connect the water supply line to the inlet. If a manual shut off valve is used, it should be mounted on the inlet line as well.

9 Connect the outlet of the aftercooler/intercooler to the inlet of the flow control valve using the pre-shaped copper tubing and compression fittings provided.

Cleaning the Volatile Trap on the Demister (W600 - 1000)

- 1 Stop the dryer and lockout the main power.** 
- 2 Remove the thumbscrews then remove the volatile demister cover.**
- 3 Remove the demister by pulling it out from the housing.**

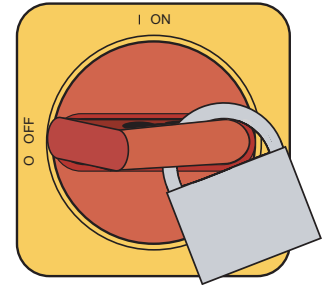

- 4 Clean the assembly using a mild soap and water.** Let the assembly dry thoroughly before installation.



NOTE: In cases of heavy volatiles, steam cleaning or the use of solvents, such as acetone, may be necessary. Be sure to test a small area with the solvent you have selected to be sure there is no adverse reaction.

- 5 Insert the demister carefully back into the housing, making sure to completely push it towards the back of its housing.**
- 6 Inspect the condition of the gasket.** If it is damaged, replace the gasket.
- 7 Secure the cover in place using the original thumbscrews.** Make sure the cable is not pinched between the housing and the cover.



Cleaning the Volatile Trap on the Demister (W1600 - 5000)

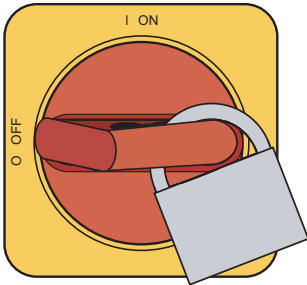

1 Stop the dryer and lockout the main power. 

2 Remove the thumbscrews then remove the volatile demister carriage and demister from its housing.

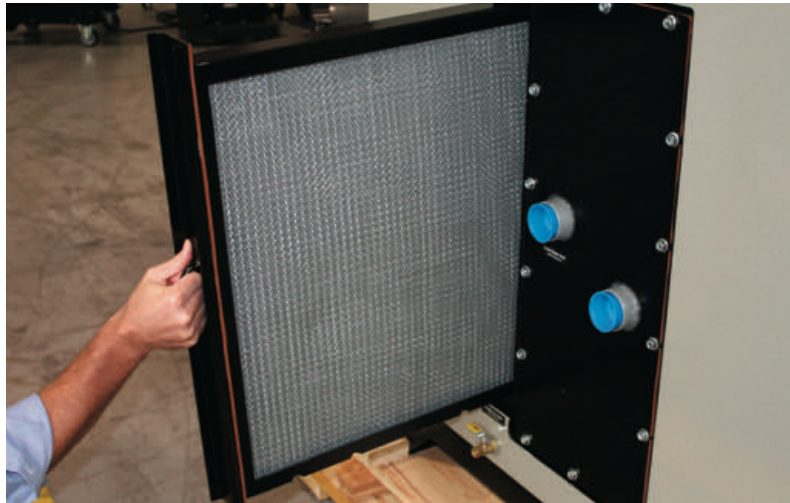

3 Remove the demister from the demister carriage by pushing it out towards the right side of the carriage.

4 Clean the assembly using a mild soap and water. Let the assembly dry thoroughly before installation.

 **NOTE:** In cases of heavy volatiles, steam cleaning or the use of solvents, such as acetone, may be necessary. Be sure to test a small area with the solvent you have selected to be sure there is no adverse reaction.

5 Insert the demister carefully back into the demister carriage and then replace the entire assembly back into the demister housing.

6 Inspect the condition of the gasket. If it is damaged, replace the gasket.

7 Secure the cover in place using the original thumbscrews.



Cleaning the Precooler Coils

You need to clean the precooler coils to keep them working efficiently. Cleaning frequency depends on the type and amount of material you process.

- 1 Stop the dryer and lockout the main power.** 
- 2 Turn off the water flow to the water supply line.** Disconnect supply and return lines.

 **NOTE:** If an optional flow control was added with the precooler, remove the compression fitting from the precooler inlet. Loosen the fitting on the flow control, then swing the copper water supply tube out and away from the precooler inlet.

- 3 Remove the bolts securing the precooler cover.** Remove the cover.
- 4 Remove the precooler by pulling it out** of the precooler housing.
- 5 Clean the assembly using a mild soap and water.** Let the assembly dry thoroughly before installation.

 **NOTE:** In cases of heavy volatiles, steam cleaning or the use of solvents, such as acetone, may be necessary. Be sure to test a small area with the solvent you have selected to be sure there is no adverse reaction.

- 6 Inspect the condition of the gasket.** If it is damaged, replace the gasket.
- 7 Reassemble** by repeating the steps in reverse order.
- 8 Connect the water supply line to the inlet.** If a manual shut off valve is used, it should be mounted on the inlet line as well.
- 9 Connect the outlet of the precooler to the inlet of the flow control valve** using the pre-shaped copper tubing and compression fittings provided.

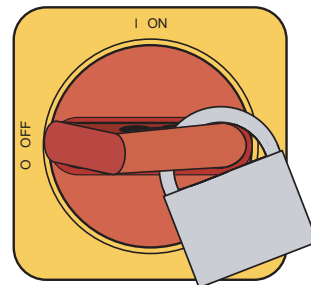

Replacing the Regeneration Heater

(W600 - 1000)

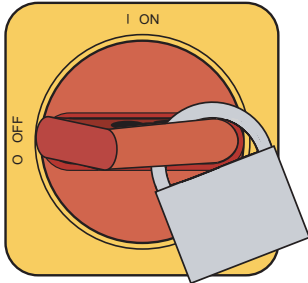

1 Stop the dryer and lockout the main power. 

2 Remove the right side panel of the dryer, as viewed from the front of the dryer, to gain access to the regeneration heater. 

3 Disconnect the regeneration heater power wires from the terminal block in the control cabinet. Feed the regeneration power cable out of the control cabinet.



IMPORTANT: Always refer to the wiring diagrams that came with your dryer to locate specific electrical components. Illustrations in the User Guide are intended to be representative only.

Clamp
Regeneration Heater
Clamp



Clamp

Insulation



4 Unplug the quick disconnect for the high temperature switch cable at the switch.

5 Loosen the hose clamps then remove the hoses from the top and bottom of the regeneration heater tube. Remove and check the bottom heater hose for loose debris or fragments, these fragments can damage the newly installed heater if not removed.

6 While supporting the heater tube, loosen the hose clamp supporting the regeneration tube to the mounting bracket, then remove the heater tube from the dryer.

7 Slide the insulation off the heater tube, or make a cut the entire length of the insulation sleeve to aid removal.

Replacing the Regeneration Heater

(W600 - 1000) (continued)



- 8** Compare the markings on the outside of the regeneration heater tube to ensure the new one has the same voltage and kW ratings as the original heater tube. This information is on the end nearest the wires.
- 9** Slide the original insulation over the new heater or, if the insulation was cut for removal, wrap the cut insulation sleeve around the new heater tube and secure it with duct tape.
- 10** Make sure the cable end of the heater tube is to the bottom then secure the new heater tube to the mounting bracket with a hose clamp.
- 11** Connect the hoses to the top and bottom of the heater tube and secure them with hose clamps.
- 12** Connect the high temperature switch wires to the quick disconnects near the heater tube.
- 13** Route the heater power cable into the control cabinet and connect the leads to the original locations on the terminal block. Refer to the wiring diagram for specific connection information.
- 14** Replace the side panel of the dryer.
- 15** Measure the resistance from each leg of the heater tube to the others and from each leg to ground. There should be +/- 5% resistance variation between all 3 legs, and high resistance from each leg to ground.
- 16** Connect the dryer to power and turn it on. Verify that the regeneration temperature achieves the setpoint.

Replacing the Regeneration Heater

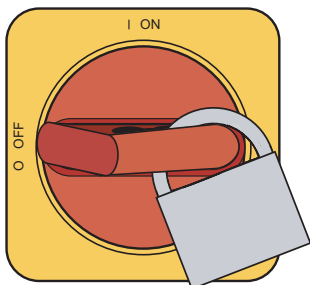
(W1600 - 2400)



IMPORTANT: Always refer to the wiring diagrams that came with your dryer to locate specific electrical components. Illustrations in the User Guide are intended to be representative only.

- 1 Stop the dryer and lockout the main power.** 
- 2 Locate the heater.** Open the side panels of the dryer locating the heater which is secured to the inlet of the desiccant wheel assembly by hard piping, brackets and clamps.  See *Installation section entitled, Checking the Dryer for Proper Air Flow, Opening and Closing the Dryer Doors (W1600-5000).*

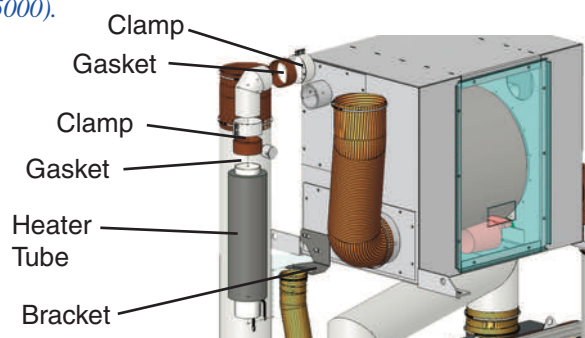

- 3 Disconnect the main power leads at the junction box inside the frame of the dryer.**
- 4 Disconnect the high temperature switch cable at the quick disconnect.**
- 5 To remove the defective regeneration heater tube, loosen the pressure clamps at the top and bottom of the heater tube connection and slide the clamp and its silicon gasket back away from the heater tube. W1600-2400 model dryers lower clamp is attached to a bracket that is mounted to the desiccant wheel assembly, loosen clamp to remove it from the bracket. Remove and check the bottom heater hose for loose debris or fragments, these fragments can damage the newly installed heater if not removed.**
- 6 Slide the insulation off the heater tube, or make a cut down the entire length of the insulation sleeve to aid removal.**
- 7 Compare the markings on the outside of the regeneration heater tube to ensure the new one has the same voltage and kW ratings as the original heater tube. This information is on the end nearest the wires.**

Replacing the Regeneration Heater

(W1600 - 2400) (continued)

- 8** Slide the original insulation over the new heater, or if the insulation was cut for removal, wrap the cut insulation sleeve around the new heater tube and secure it with heat tape.
- 9** Make sure the cable end of the new heater tube is to the bottom, then connect the hoses to the top and bottom of the heater tube and resecure with pressure clamps and the lower heater tube bracket that was removed in Step 5.
- 10** Connect the high temperature switch cable to the quick disconnect.
- 11** Route the heater power wires into the junction box, and connect them to the supply leads from the control box. Refer to the wiring diagram for specific connection information.
- 12** To ensure all connections are correct, measure the resistance as in Step 3. You should measure the readings as noted for a good heater.
- 13** Close the side panel of the dryer.
- 14** Connect the dryer to power and turn it on. Verify the regeneration temperature achieves the setpoint.

Replacing the Regeneration Heater (W3200 - 5000)

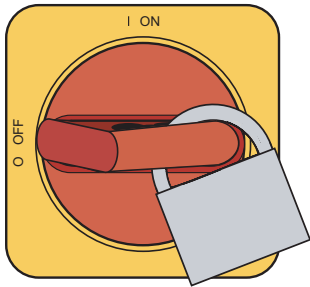

IMPORTANT: Always refer to the wiring diagrams that came with your dryer to locate specific electrical components. Illustrations in the User Guide are intended to be representative only.

1 Stop the dryer, disconnect and lockout the main power.

2 Locate the heater(s). Open the side panels of the dryer locating the heaters which are secured to the inlet of the desiccant wheel assembly by hard piping, a heater tube manifold, brackets and clamps. *See Installation section entitled, Checking the Dryer for Proper Air Flow, Opening and Closing the Dryer Doors (W1600-5000).*

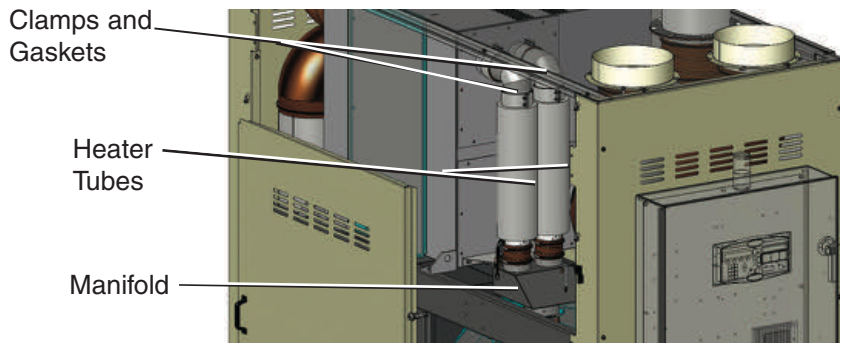

3 Disconnect the main power leads at the junction box inside the frame of the dryer. In units with two heaters (W3200 and W5000), it may be necessary to measure resistance across the power leads of each heater tube to determine which heater needs to be replaced. In a good element, the resistance across all three legs should be +/- 5% resistance variation when measured leg-to-leg, and high resistance from each leg to ground. Readings other than this indicate a defective heater.

4 Disconnect the high temperature switch cables at the quick disconnects.

5 Loosen the pressure clamps at the top and bottom of the heater tube connection and slide the clamp and its silicon gasket back and away from the heater tube to remove the defective regeneration heater tube(s). W3200-5000 model dryers lower heater clamp(s) are attached to a manifold that is secured to the desiccant wheel assembly with a bracket, loosen the clamp that secures the heater tube to the manifold to remove it from the dryer.

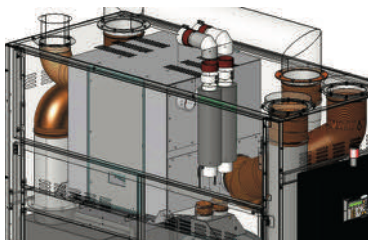



Replacing the Regeneration Heater

(W3200 - 5000) (continued)

- 6** Loosen the two (2) lower clamps that secure the regeneration manifold and tubing to the desiccant wheel bracket. Remove the regeneration manifold and the tubing that is attached to the bottom of the manifold. Then remove the tubing from the regeneration blower outlet and check for loose particles within the tubing, clean as necessary. Reverse this procedure to reinstall the regeneration manifold and tubing.
- 7** Slide the insulation off the heater tube(s), or make a cut down the entire length of the insulation sleeve to aid removal.
- 8** Compare the markings on the outside of the regeneration heater tube to ensure the new one has the same voltage and kW ratings as the original heater tube. This information is on the end nearest the wires.
- 9** Slide the original insulation over the new heater, or if the insulation was cut for removal, wrap the cut insulation sleeve around the new heater tube and secure it with heat tape.
- 10** Make sure the cable end of the new heater tube is to the bottom, then reconnect the hoses to the top and bottom of the heater tube and resecure with pressure clamps that were removed in Step 5.
- 11** Connect the high temperature switch cable to the quick disconnect.
- 12** Route the heater power wires into the junction box and connect them to the supply leads from the control box. Refer to the wiring diagram for specific connection information.
- 13** To ensure all connections are correct, measure the resistance as in Step 3. You should measure the readings as noted for a good heater.
- 14** Close the side panel of the dryer.
- 15** Connect the dryer to power and turn it on. Verify the regeneration temperature achieves the setpoint.

Checking the Dew Point

 **NOTE:** Portable dew point monitors purchased from Conair are provided with a male connector that plugs into the dew point check port. If you purchased your portable instrument elsewhere, the male connector is available through the Conair parts department.

 **NOTE:** The dew point check port was not included on the initial release of these dryers. It can be added easily. Contact the Conair parts department or follow the alternate procedure.

Replacement dew point monitors, male connectors and dew point check ports are available from Conair.

Contact Conair Parts
(800) 458 1960
From outside of the
United States, call:
(814) 437 6861

Conair recommends monitoring the dew point performance of your dryer periodically with a calibrated portable dew point monitor, to ensure it is performing at maximum capacity. Even if your dryer has a dew point readout, comparing it to a portable instrument periodically will confirm that the dew point sensor and readout is performing properly.

To check dew point:

- 1 Connect your portable dew point meter to the dew point check port of the dryer.**



- 2 Turn on the portable instrument, and ensure there is positive air flow through the sensor.**

Checking the Dew Point (continued)

- 3 Monitor the readout and allow ample time for it to stabilize before disconnecting the portable dew point monitor.** Some dew point monitors require a substantial amount of time for residual moisture to be purged from the sensor.
- 4 In the event the dew point is not satisfactory,** refer to the *Troubleshooting section* of the manual, under Process dew point alarm for DC2.

Replacement dew point monitors, male connectors and dew point check ports are available from Conair.

Contact Conair Parts
(800) 458 1960
From outside of the
United States, call:
(814) 437 6861

Replacement dust collector filters are available from Conair.

Contact Conair Parts
(800) 458 1960
From outside of the
United States, call:
(814) 437 6861

Cleaning the Dust Collector (optional)

A clogged filter in a dust collector will negatively affect air flow and the EnergySmart Drying System's efficiency. Cleaning frequency depends on how much material you process and how dusty and full of fines it is.

 **NOTE:** Turn off the EnergySmart Drying System and allow it to cool before attempting any maintenance.

 **CAUTION:** Hot surfaces. Always protect yourself from hot surfaces inside and outside the components of the EnergySmart Drying System.

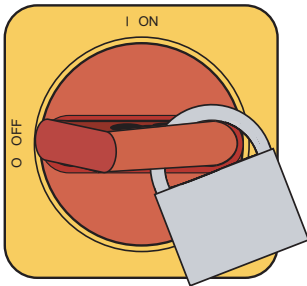

1 Turn off and lock out the power to the EnergySmart Drying System and its components. 

2 Release the four (4) latches securing the dust collector tank by pulling down on each latch. As the latches are released, a "hook" will still be holding the tank to the lock ring on the main dust collector body.

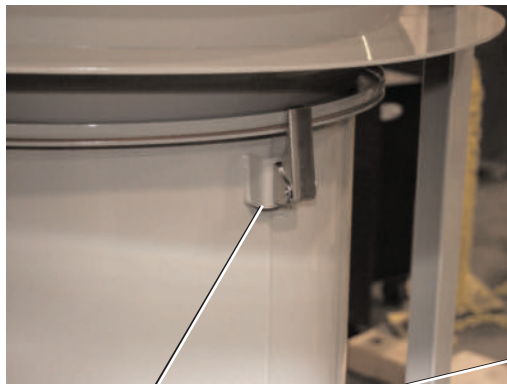

or

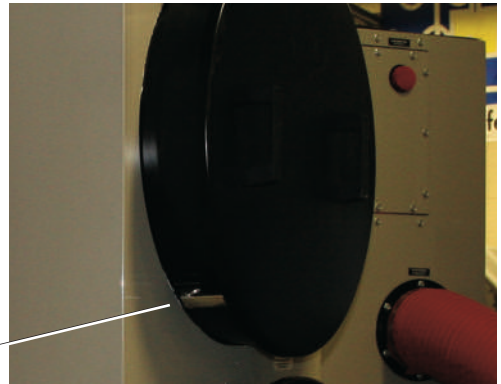

Latch (4)

3 Lift up on the tank and release the "hooks" holding the tank to the lock ring, while supporting the weight of the dust collector tank. Once all four (4) "hooks" are released, the tank is free of the dust collector body.

Cleaning the Dust Collector (optional)

(continued)



- 4 Empty any material from the tank into an appropriate container.** Remove any dust that clings to the inside of the tank with a cleaning cloth.

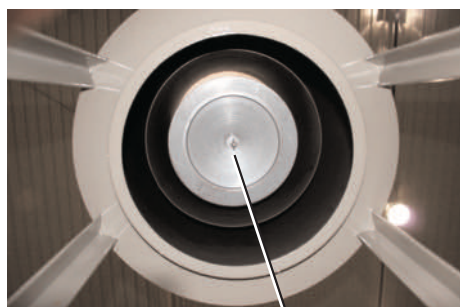

Wing nut

- 5 Remove the dust collector filter element** by removing the wing nut securing the filter in the dust collector body. Once the wing nut is removed, remove the filter from the bottom of the dust collector.

Cleaning the Dust Collector (optional)

(continued)

•➤ **TIP:** If gasket on the filter tank becomes loose or detached from the filter cap, resecure with high temperature silicone adhesive.



6 Clean the dust collector filter using a vacuum. If using a vacuum, repeatedly apply the vacuum to the outside of the filter element until all debris is removed. Replace the filter if it is damaged, worn or still clogged after cleaning.



CAUTION: Wear eye protection. If you use compressed air to clean the equipment, **you must wear eye protection** and observe all OSHA and other safety regulations pertaining to the use of compressed air.

7 Install the filter in the dust collector by aligning it on the stud then sliding it up into the dust collector.

8 Secure the filter in the dust collector by installing the wing nut. Tighten the wing nut by hand to insure a tight fit at the top of the filter.

9 Reinstall the dust collector tank by engaging the tank latch hooks on the lock ring on the dust collector body. Once all for "hooks" are engaged, lift up on the latches to secure the tank to the dust collector body.

Cleaning the Cyclone Separator

(optional)

A filled cyclone separator barrel will negatively affect air flow and the EnergySmart Drying System's efficiency. Cleaning frequency depends on how much material you process and how dusty and full of fines it is.

 **NOTE:** Turn off the EnergySmart Drying System and allow it to cool before attempting any maintenance.

1 Turn off and lock out the power to the EnergySmart Drying System and its components. 

2 Release the four (4) latches securing the cyclone separator barrel's lid by pulling down on each latch. As the latches are released, a "hook" will still be holding the lid to the barrel.

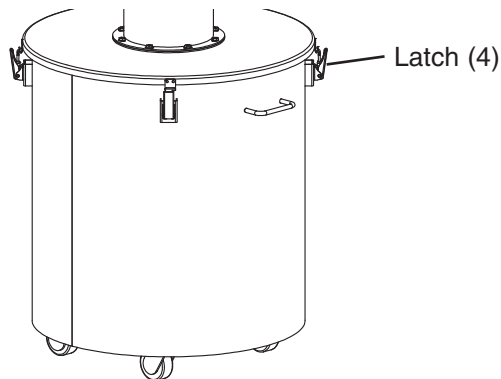

3 Lift up on the lid and release the "hooks" holding the lid to the barrel.

4 Empty any material from the barrel into an appropriate container. Remove any dust that clings to the inside of the barrel with a cleaning cloth.

5 Reinstall the lid by engaging the barrel latch hooks. Once all for "hooks" are engaged, lift up on the latches to secure the lid to the barrel.

Troubleshooting

Before beginning 6-2

A few words of caution 6-3

DIAGNOSTICS

How to identify the cause of a problem 6-4

Shutdown alarms 6-7

Passive alarms 6-14

Dew point troubleshooting 6-28

Poor material drying troubleshooting 6-29

REPAIR

Replacing fuses 6-34

Checking heater solid state relays 6-35

Checking or replacing temperature sensors . 6-36

Replacing the desiccant wheel

assembly (W600-1000) 6-37

Replacing the desiccant wheel

motor (W600-1000) 6-39

Replacing the desiccant wheel

motor (W1600 - 5000) 6-40

Before Beginning

You can avoid most problems by following the recommended installation and maintenance procedures outlined in this User Guide. If you do have a problem, this section will help you determine what caused it and how to fix it.

Before you start accessing any EnergySmart Dryer System component, be sure to:

- ❑ **Diagnose causes from the control panel.**

- 1 Navigate to the Alarm Log Screen (13).** The alarm log lists the alarms that have been registered in the EnergySmart Dryer System as well as the date and time of the alarm.

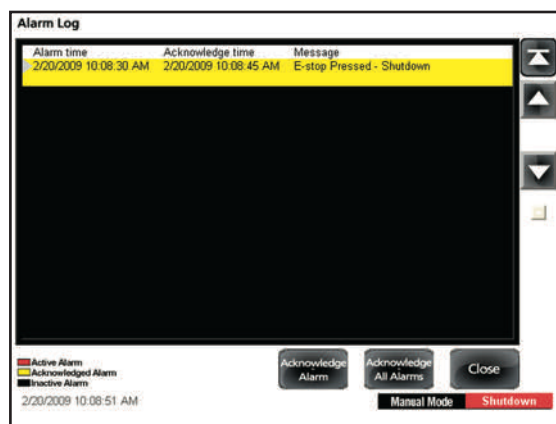

- 2 Address the alarm message and fix the problem.** (Refer to the alarm descriptions later in this section.)

- 3 Press the "Acknowledge Alarm" button to acknowledge the highlighted alarm or the "Acknowledge All Alarms" button to acknowledge all alarms registered on the system.** If the alarm reappears, the problem was not fixed.

- ❑ Find the wiring and equipment diagrams that were shipped with your EnergySmart Dryer System. These diagrams are the best reference for correcting a problem. The diagrams also will note any custom features, such as special wiring or alarm capabilities, not covered in this User Guide. You can avoid most problems by following the recommended installation and maintenance procedures outlined in this User Guide. If you do have a problem, this section will help you determine what caused it and how to fix it.

A Few Words of Caution

The EnergySmart™ PET Drying System and its components are equipped with numerous safety devices. Do not remove or disable them. Improper corrective action can lead to hazardous conditions and should never be attempted to sustain production.



WARNING: Only qualified service personnel should examine and correct problems that require opening the dryer's electrical enclosure or using electrical wires to diagnose the cause.



WARNING: High voltage. Always stop the EnergySmart Dryer System, disconnect and lock out the main power source before troubleshooting or performing repairs.



CAUTION: Hot surfaces. Always protect yourself from hot surfaces inside and outside of the dryer and hopper.

How to Identify the Cause of a Problem

Most EnergySmart™ PET Drying System malfunctions are indicated in the Status Box on the Control Panel screens. Alarms can also be viewed by pressing the Alarm Log button on the Control Panel. The Alarm Log tracks the last 200 alarms registered.

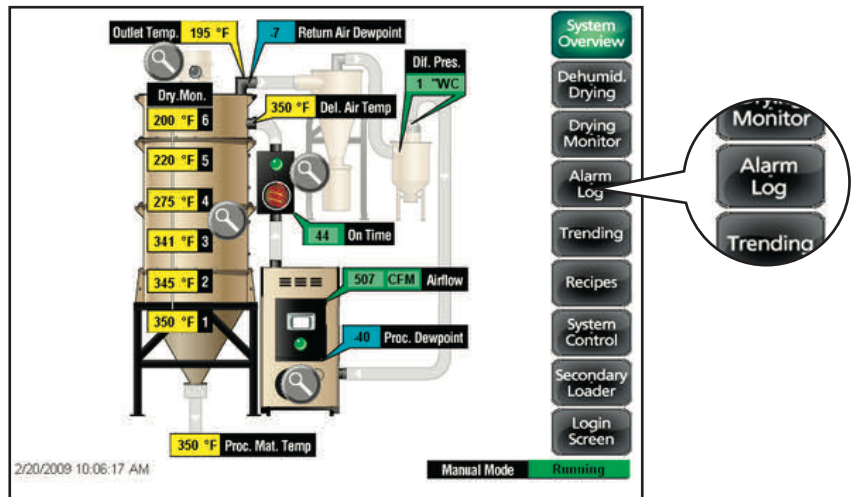

A malfunction within the EnergySmart Dryer System or one of its components can trigger two types of alarms. Passive alarms for the EnergySmart Dryer System or its components. Shutdown alarms for the components within the EnergySmart Dryer System.

 **NOTE:** Consult the User Manuals supplied for the individual EnergySmart Dryer System components for detailed information on alarms for each system component.

A malfunction within the EnergySmart Drying System or one of its components can trigger two types of alarms:

- **Passive Alarm:** The EnergySmart Dryer System continues to operate, but warns of a problem that could prevent correct processing of your material. If ignored, this problem could lead to a condition that will shutdown a system component.
- **Shut Down Alarm:** The EnergySmart Dryer and system components have automatically shutdown because it detected a serious problem that could damage your material or components.

How to Identify the Cause of a Problem (continued)

When the audible alarm is heard or optional alarm light illuminates:

- 1 Press the “Alarm Log” button to access the alarm history and note the newest alarm(s).

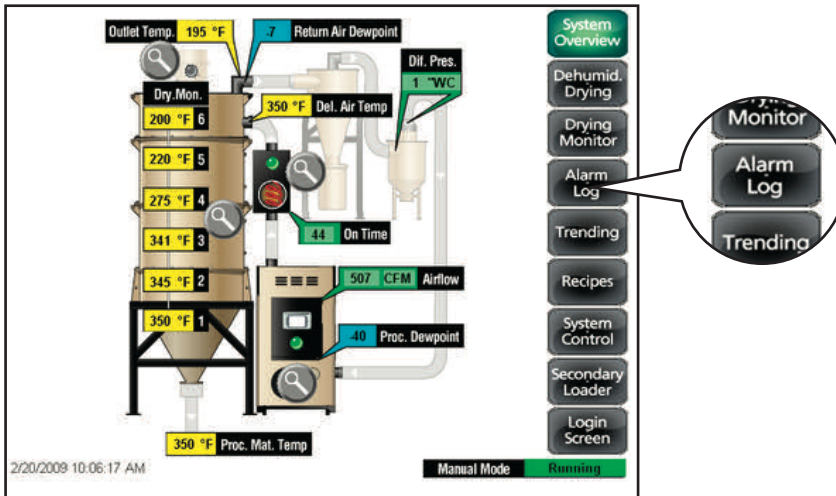

- 2 Press either the “Acknowledge Alarm” or “Acknowledge All Alarms” button.

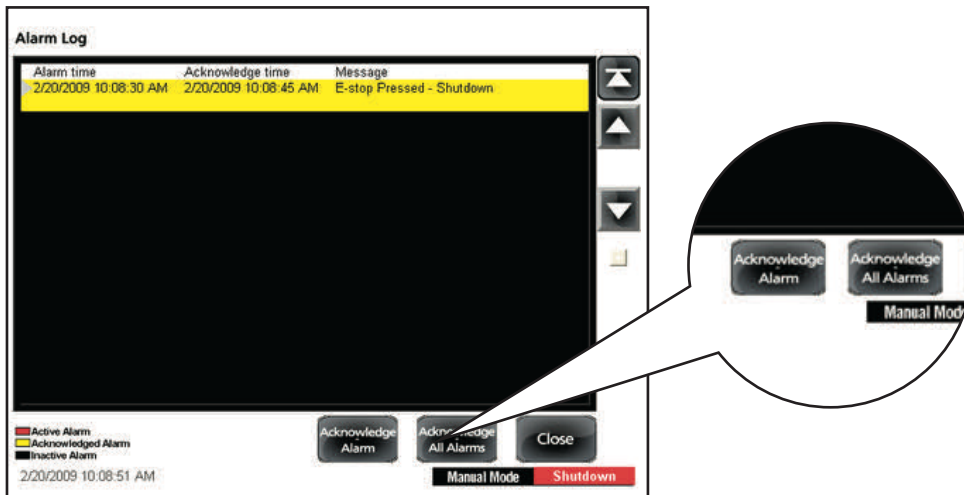

How to Identify the Cause of a Problem (continued)

- 3 Find the error message in the diagnostics table of this troubleshooting section** or the troubleshooting section of the applicable component User Manual. Take any necessary steps, as directed, to resolve the problem.
- 4 Note that, after correcting the problem, if the problem was not solved, the alarm will become reactivate.**

There may also be a second alarm condition that occurred as a result of the first alarm.

Shutdown Alarms

If an alarm occurs, a red dialog box is displayed on the dryer's touch screen control. The dryer will shut down automatically to prevent damage to the equipment or personnel. The dialog box will indicate whether the alarm is a shut down alarm or a passive alarm.

Problem	Possible cause	Solution
<p>Regeneration Heater Box High Temperature – The snap switch in the regeneration heater tube activated due to excessive temperature.</p>	<p>The regeneration exhaust is blocked or the air hoses are loose.</p> <p>The regeneration blower is not running or running in the wrong direction.</p> <p>The isolation contactor failed in the closed position.</p> <p>The heater solid state relays (SSRs) failed.</p> <p>The regeneration heater output on the board has failed.</p>	<p>Locate and remove any air flow restrictions.</p> <p>Tighten any loose hoses.</p> <p>Correct the cause of the non-running blower (fuse, etc.) or reverse the rotation of the blower.</p> <p>Replace the isolation contactor.</p> <p>Replace the failed heater solid state relays (SSRs).</p> <p>Replace the board.</p>
<p>Return Air High Temperature – If the return air temperature at the inlet to the blower is greater than 180°F {82°C}, it shuts down the dryer. (The return air temperature on W1600-5000 dryers is measured at the inlet to the desiccant wheel.)</p>	<p>The hopper does not contain enough material.</p> <p>You are drying at a high drying temperature above 180°F {82°C} or you are running at low throughputs.</p> <p>The aftercooler/intercooler does not have enough water.</p> <p>The aftercooler/intercooler coils are dirty.</p>	<p>Make sure your material supply system is working properly.</p> <p>Ensure water flow to the aftercooler/intercooler.</p> <p>Turn on the water supply, or fix any leaks or blockages.</p> <p>Clean the aftercooler/intercooler coils. <i>See Maintenance section entitled, Cleaning the aftercooler/intercooler coils.</i></p>

Shutdown Alarms

If an alarm occurs, a red dialog box is displayed on the dryer's touch screen control. The dryer will shut down automatically during a to prevent damage to the equipment or personnel. The dialog box will indicate whether the alarm is a shut down alarm or a passive alarm.

Problem	Possible cause	Solution
<p>Regeneration Temperature RTD Integrity – If the regeneration RTD is faulty, it shuts down the dryer.</p> <p>Process Blower Overload - If the process blower exceeds its full load amp rating or the overload has tripped due to a mechanical or electrical problem the dryer will shut down.</p>	<p>There is a loose connection in the wiring leading to the RTD.</p>	<p>Check the RTD plug connection and make necessary repairs.</p>
	<p>The connection of the RTD plug on the control board is loose.</p>	<p>Check the plug connection and tighten if needed.</p>
	<p>The regeneration RTD has failed.</p>	<p>Replace the regeneration RTD.</p>
	<p>The control board has failed.</p>	<p>Replace the control board.</p>
	<p>The process blower current draw has exceeded the full load amps rating of the motor.</p>	<p>Press alarm acknowledge and allow the overload to reset then try to restart the dryer. If the alarm condition occurs again have a qualified electrician check the current draw to the motor.</p>
	<p>The process blower has mechanically failed or is unable to rotate freely.</p>	<p>Disconnect and lock out main power. Check the process blower for mechanical failure and free rotation. Replace if necessary. Allow the overload to reset then try to restart the dryer.</p>
	<p>The process blower has failed electrically.</p>	<p>Disconnect and lock out main power. Check the process blower for electrical shorts or open circuits. Replace if necessary. Allow the overload to reset then try to restart the dryer.</p>
	<p>Loss of phase of power to the motor starter.</p>	<p>Check for a blown fuse in the dryer or main power supply. Allow the overload to reset then try to restart the dryer.</p>
	<p>The overload is set incorrectly.</p>	<p>Disconnect and lock out main power. Check the overload settings and confirm that the settings match the full load amps listed on the process blower motor. Allow the overload to reset then try to restart the dryer.</p>
	<p>The overload is defective.</p>	<p>Replace the overload.</p>

Shutdown Alarms

If an alarm occurs, a red dialog box is displayed on the dryer's touch screen control. The dryer will shut down automatically during a to prevent damage to the equipment or personnel. The dialog box will indicate whether the alarm is a shut down alarm or a passive alarm.

Problem

Regeneration Blower Overload - If the regeneration blower exceeds its full load amp rating or the overload has tripped due to a mechanical or electrical problem the dryer will shut down. The default setting for this alarm is passive but it can be changed to shutdown.



NOTE: This alarm shuts down only the regeneration portion of the dryer. The process blower will continue to run.

Possible cause

The regeneration blower current draw has exceeded the full load amps rating of the motor.

The regeneration blower has mechanically failed or is unable to rotate freely.

The regeneration blower has failed electrically.

Loss of phase of power to the motor starter.

The overload is set incorrectly.

The overload is defective.

Solution

Press alarm acknowledge and allow the overload to reset then try to restart the dryer. If the alarm condition occurs again have a qualified electrician check the current draw to the motor.

Disconnect and lock out main power. Check the regeneration blower for mechanical failure and free rotation. Replace if necessary. Allow the overload to reset then try to restart the dryer.

Disconnect and lock out main power. Check the regeneration blower for electrical shorts or open circuits. Replace if necessary. Allow the overload to reset then try to restart the dryer.

Check for a blown fuse in the dryer or main power supply. Allow the overload to reset then try to restart the dryer.

Disconnect and lock out main power. Check the overload settings and confirm that the settings match the full load amps listed on the process blower motor. Allow the overload to reset then try to restart the dryer.

Replace the overload.

Shutdown Alarms

If an alarm occurs, a red dialog box is displayed on the dryer's touch screen control. The dryer will shut down automatically during a to prevent damage to the equipment or personnel. The dialog box will indicate whether the alarm is a shut down alarm or a passive alarm.

Problem	Possible cause	Solution
E-Stop Press	E-Stop button has been pressed in.	Release E-Stop.
Process High Temperature – If the process temperature exceeds the process high temperature setpoint, it shuts down the dryer. Defaults are set to 385°F {196°C} for 20 seconds.	The process high temperature setpoint is not at least 10°F {6°C} above the drying setpoint.	Reset the process high temperature setpoint at least 10°F {6°C} above the drying setpoint.
	One of the process solid state relays has failed.	Replace the solid state relay.
	The air lines are restricted or loose.	Straighten any crimps in the hoses. Tighten any loose hoses.
	The process setpoint is too low.	Set the process setpoint higher or install an optional precooler.
Process Temperature Loop Break – If the process temperature is outside of the operator entered deviation, alarm band (see Process High Temperature Deviation passive alarm) and the process temperature is not moving towards the setpoint at a rate greater than specified. It shuts down the dryer. Defaults are set at 3°F {3°C} over 20 seconds.	The process heater output on the control board has failed.	Replace the control board.
	Process RTD is loose or has fallen out.	Check the process RTD and tighten if needed.
	The process heater has failed.	Check the heater fuses, and resistance across each leg of the process heater.
	The air lines are restricted or loose.	Straighten any crimps in the hoses. Tighten any loose hoses.
	The process blower is not running or is running in the wrong direction.	Correct the cause of the non-running blower (blown fuse, etc.) or reverse the rotation of the blower.
	The process heater output on the board has failed or the output fuse has failed.	Replace the board or the fuse for the output.
	Process setpoint is too low.	Adjust the setpoint or add a precooler.
Setback setpoint is too low.	Adjust the setpoint or add a precooler.	

Shutdown Alarms

If an alarm occurs, a red dialog box is displayed on the dryer's touch screen control. The dryer will shut down automatically during a to prevent damage to the equipment or personnel. The dialog box will indicate whether the alarm is a shut down alarm or a passive alarm.

Problem	Possible cause	Solution
<p>Process Heater Box High Temperature – The snap switch in the process heater tube opens due to excessive temperature.</p>	<p>There is an air flow blockage or loose hoses.</p> <p>The process blower is not running or running in the wrong direction.</p> <p>The isolation contactor failed in the closed position.</p> <p>The process heater output on the board has failed.</p> <p>The heater solid state relays (SSRs) failed.</p>	<p>Locate and remove any air flow restrictions.</p> <p>Tighten any loose hoses.</p> <p>Correct the cause of the non-running blower (blown fuse, etc.) or reverse the rotation of the blower.</p> <p>Replace the isolation contactor.</p> <p>Replace the board.</p> <p>Replace the failed heater solid state relays (SSRs).</p>
<p>Heat Booster RTD Integrity – If the process RTD is faulty, it shuts down the dryer.</p>	<p>The process RTD connection to the control box is loose.</p> <p>The connection in the electrical enclosure for the process RTD is loose.</p> <p>The connection of the RTD plug on the control board is loose.</p> <p>The process RTD has failed.</p> <p>The control board has failed.</p>	<p>Check the connection to the receptacle and tighten if needed.</p> <p>Check the RTD plug connection and tighten if needed.</p> <p>Check the plug connection and tighten if needed.</p> <p>Replace the process RTD.</p> <p>Replace the control board.</p>
<p>Process Blower Drive Fault – If the process blower drive has faulted, this alarm will occur.,</p>	<p>There is a fault at the drive unit.</p>	<p>Refer to your drive unit's instruction manual.</p>

Shutdown Alarms

If an alarm occurs, a red dialog box is displayed on the dryer's touch screen control. The dryer will shut down automatically during a to prevent damage to the equipment or personnel. The dialog box will indicate whether the alarm is a shut down alarm or a passive alarm.

Problem	Possible cause	Solution
Process Blower Drive Fault	The variable speed drive is not operating correctly.	<i>See ABB Variable Frequency Drive Manual.</i>
Process Protection High Temperature – If the process protection temperature exceeds the process protection high temperature setpoint, it shuts down the dryer. Defaults are set to 600°F {316°C} for 10 seconds.	<p>The process RTD temperature probe is not installed correctly.</p> <p>The process blower is not running.</p> <p>The air lines between the dryer and hopper are restricted or loose.</p> <p>The dryer is too far from the hopper.</p> <p>The process hose is not insulated.</p>	<p>Make sure the RTD temperature probe tip is in the center of the hopper inlet tube.</p> <p>Correct the cause of the non-functioning blower.</p> <p>Straighten any crimps in the hoses. Tighten any loose hoses.</p> <p>Move the dryer closer to the hopper and shorten the hoses.</p> <p>Insulated hose is required for high drying temperatures.</p>
Process Protection Temperature Differential - If the difference between the process temperature exiting the process heater and the temperature of the air entering the hopper is greater than 175°F {97°C} for longer than 180 seconds it shuts down the dryer.	<p>The air lines between the dryer and hopper are restricted or loose.</p> <p>The dryer is located too far away from the hopper.</p> <p>The process RTD is loose or has fallen out.</p> <p>The process blower is not running.</p> <p>The process hose is not insulated.</p>	<p>Check for air flow blockages or loose hoses between the outlet of the dryer and the inlet of the hopper. Straighten any crimps in the hoses. Tighten any loose hoses.</p> <p>The dryer and the hopper should not be located more than 10 feet {3 m} apart.</p> <p>Check the process RTD and tighten if needed.</p> <p>Correct the cause of the non-functioning blower.</p> <p>Insulated hose is required for high drying temperatures.</p>

Shutdown Alarms

If an alarm occurs, a red dialog box is displayed on the dryer's touch screen control. The dryer will shut down automatically during a to prevent damage to the equipment or personnel. The dialog box will indicate whether the alarm is a shut down alarm or a passive alarm.

Problem	Possible cause	Solution
<p>Process Protection RTD Integrity – If the process protection RTD is faulty, it shuts down the dryer.</p>	<p>There is a loose connection in the wiring leading to the RTD.</p> <p>The connection of the RTD plug on the control board is loose.</p> <p>The process protection RTD has failed.</p> <p>The control board has failed.</p>	<p>Check the RTD plug connections and make any necessary repairs.</p> <p>Check the plug connection and tighten if needed.</p> <p>Replace the process protection RTD.</p> <p>Replace the control board.</p>
<p>Regeneration High Temperature – If the regeneration temperature exceeds the high temperature limit for the specified time. Default values are 400°F {204°C} for 20 seconds.</p>	<p>One of the solid state relays (SSRs) failed in the closed position.</p> <p>The output on the board has failed.</p>	<p>Replace the failed solid state relays (SSRs).</p> <p>Replace the board.</p>
<p>Regeneration Temperature Loop Break – The regeneration temperature is outside of the operator entered deviation alarm band (see Regeneration Temperature Deviation passive alarm) and the regeneration temperature is not moving towards the setpoint at a rate greater than specified. Default values are 2°F {1°C} over 40 seconds.</p>	<p>The regeneration heater has failed.</p> <p>The regeneration RTD is loose or has fallen out.</p> <p>The regeneration blower is not running.</p> <p>The output on the control board has failed or the fuse is blown.</p>	<p>Check the heater fuses, and resistance across each leg of the process heater.</p> <p>Check the regeneration RTD and tighten if needed.</p> <p>Check wiring or replace regeneration blower.</p> <p>Replace the control board or fuse.</p>
<p>Wheel Rotation Failure - The regeneration temperature differential has been reached. The default differential is 20°F / 10 seconds.</p>	<p>The wheel motor is not turning.</p> <p>The belt tensioner is loose or the belt is slipping.</p> <p>The regeneration heater is not working.</p>	<p>Check the motor, plugs, and fuses.</p> <p>Change the tensioner spring or replace the belt.</p> <p>Check the heater fuses and heater.</p>

Passive Alarms

If an alarm occurs, a red dialog box is displayed on the dryer's touch screen control. The dryer continues to operate, but this problem could prevent correct drying of your material. The dialog box will indicate whether the alarm is a shut down alarm or a passive alarm.

Problem	Possible cause	Solution
<p>Process Temperature Deviation – The process temperature exceeds the deviation band as entered for the specified time. Default values are 10°F {6°C} for 5 seconds.</p> <p>Process Low Temperature – The process temperature is less than the low temperature setpoint for the specified time. Default values are 70°F {21°C} for 20 seconds.</p>	<p>One of the solid state relays (SSRs) failed in the closed position.</p>	<p>Replace the failed solid state relays (SSRs).</p>
	<p>Defective process heater.</p>	<p>Check the heater fuses and resistance across each leg of the process heater.</p>
	<p>The output on the board has failed.</p>	<p>Replace the board.</p>
	<p>The process RTD is loose or has fallen out.</p>	<p>Check the process RTD and tighten if needed.</p>
	<p>The air hose connections are loose.</p>	<p>Tighten all air hose connections.</p>
	<p>Precooler water is too cold, or the water flow rate is too high.</p>	<p>Check water temperature and flow settings. Adjust as necessary.</p>
	<p>The output on the board has failed.</p>	<p>Replace the board.</p>
	<p>Flow control solenoid is stuck open.</p>	<p>Replace the valve.</p>
	<p>The process RTD is loose or has fallen out.</p>	<p>Check the process RTD and tighten if needed.</p>
	<p>Process heater has failed.</p>	<p>Check the heater fuses and resistance across each leg of the process heater.</p>

Passive Alarms

If an alarm occurs, a red dialog box is displayed on the dryer’s touch screen control. The dryer continues to operate, but this problem could prevent correct drying of your material. The dialog box will indicate whether the alarm is a shut down alarm or a passive alarm.

Problem	Possible cause	Solution
<p>Process dew point – The dew point has not fallen below the setpoint. If the dew point goes below the setpoint for 180 seconds the alarm should go away.</p> <p> NOTE: The alarm is not active for the first 5 minutes.</p>	<p>Defective dew point sensor.</p> <p>The hose or wiring connections to the sensor block are loose or have fallen off.</p> <p>Poor regeneration air flow.</p> <p>The desiccant wheel may be contaminated.</p> <p>Desiccant wheel not turning.</p> <p>Leaks in the process air stream.</p> <p>Power Purge blower not running.</p>	<p>Replace the sensor.</p> <p>Check wiring and hose connections to the sensor, resecure if needed.</p> <p>Remove the air flow restrictions, dirty filters, etc.</p> <p>Check the desiccant for contamination, replace if needed. Install plasticizer / volatile trap for severe situations.</p> <p>Replace the desiccant wheel. <i>See Troubleshooting section entitled, Replacing the desiccant wheel.</i></p> <p><i>See Troubleshooting section entitled, Passive alarms, Wheel rotation alarm.</i></p> <p>Check for worn or loose hoses.</p> <p>Check fuses, wiring or replace blower.</p>
<p>DC Filter Clogged – The optional dust collector’s differential pressure switch is tripped.</p>	<p>The optional dust collector’s filter is clogged.</p>	<p>Remove and clean or replace the process air filter.</p>
<p>Process Air Flow High</p>	<p>Process air flow setpoint is above the alarm setpoint.</p>	<p>Decrease the CFM of the dryer.</p>
<p>Process Air Flow Low</p>	<p>Process air flow setpoint is below the alarm setpoint.</p>	<p>Increase the CFM of the dryer.</p>

Passive Alarms

If an alarm occurs, a red dialog box is displayed on the dryer's touch screen control. The dryer continues to operate, but this problem could prevent correct drying of your material. The dialog box will indicate whether the alarm is a shut down alarm or a passive alarm.

Problem	Possible cause	Solution
<p>Regeneration Temperature Deviation – The regeneration temperature exceeds the deviation band for the specified time. Default values are 10°F {6°C} for 5 seconds.</p>	<p>One of the solid state relays (SSRs) failed.</p> <p>The regeneration RTD is loose or has fallen out.</p> <p>The air hose connections are loose.</p> <p>The output on the board has failed.</p> <p>Defective regeneration heater.</p>	<p>Replace the failed solid state relays (SSRs).</p> <p>Check the regeneration RTD and tighten if needed.</p> <p>Tighten all air hose connections.</p> <p>Replace the board.</p> <p>Check the heater fuses and resistance across each leg of the regeneration heater.</p>
<p>Regeneration Outlet After the Wheel RTD Integrity - The control can not sense the regeneration outlet RTD.</p>	<p>There is a loose connection in the wiring leading to the RTD.</p> <p>The connection of the RTD plug on the control board is loose.</p> <p>The regeneration outlet RTD has failed.</p> <p>The control board has failed.</p>	<p>Check the RTD plug connection and make any necessary repairs.</p> <p>Check the plug connection and tighten if needed.</p> <p>Replace the regeneration outlet RTD.</p> <p>Replace the control board.</p>
<p>Return Air Mid-High Temperature – If the return air temperature is between 150 and 180°F {66 and 82°C}.</p>	<p>The hopper does not contain enough material.</p> <p>You are drying at a high drying temperature above 120°F {49°C} or running at low throughputs.</p> <p>The aftercooler/intercooler does not have enough water.</p> <p>The aftercooler/intercooler coils are dirty.</p>	<p>Make sure your material supply system is working properly.</p> <p>Ensure water flow to the aftercooler/intercooler.</p> <p>Turn on the water supply, or fix any leaks or blockages.</p> <p>Clean the aftercooler/intercooler coils. <i>See Maintenance section entitled, Cleaning the aftercooler/intercooler coils.</i></p>

Passive Alarms

If an alarm occurs, a red dialog box is displayed on the dryer's touch screen control. The dryer continues to operate, but this problem could prevent correct drying of your material. The dialog box will indicate whether the alarm is a shut down alarm or a passive alarm.

Problem	Possible cause	Solution
<p>Regeneration Low Temperature – The regeneration temperature is less than the low temperature setpoint for the specified time. Defaults are 200°F {93°C} for 20 seconds.</p>	<p>The regeneration heater has failed.</p> <p>The output on the control board has failed or the fuse has blown.</p> <p>The regeneration RTD is loose or has fallen out.</p>	<p>Check the heater fuses, and resistance across each leg of the process heater.</p> <p>Replace the control board or the fuse.</p> <p>Check the regeneration RTD and tighten if needed.</p>
<p>Return Air Temperature RTD Integrity – The dryer continues to run with a passive alarm.</p>	<p>There is a loose connection in the wiring leading to the RTD.</p> <p>The connection of the RTD plug on the control board is loose.</p> <p>The return air RTD has failed.</p> <p>The control board has failed.</p>	<p>Check the RTD plug connections and make any necessary repairs.</p> <p>Check the plug connection and tighten if needed.</p> <p>Replace the return air RTD.</p> <p>Replace the control board.</p>
<p>Process Material Temperature RTD Integrity</p>	<p>The temperature RTD is damaged or malfunctioning.</p>	<p>Replace the RTD.</p>
<p>Return Air Temperature out of the hopper RTD Integrity – If the return air RTD is faulty, it shuts down the dryer.</p>	<p>There is a loose connection in the wiring leading to the RTD.</p> <p>The connection of the RTD plug on the control board is loose.</p> <p>The return air RTD has failed.</p> <p>The control board has failed.</p>	<p>Check the RTD plug connections and make any necessary repairs.</p> <p>Check the plug connection and tighten if needed.</p> <p>Replace the return air RTD.</p> <p>Replace the control board.</p>

Passive Alarms

If an alarm occurs, a red dialog box is displayed on the dryer's touch screen control. The dryer continues to operate, but this problem could prevent correct drying of your material. The dialog box will indicate whether the alarm is a shut down alarm or a passive alarm.

Problem	Possible cause	Solution
System Start Failed	A component(s) within the EnergySmart Dryer system has failed to start after a system start.	Determine which component(s) within the EnergySmart Dryer system did not start and troubleshoot the component(s).
System Stop Failed	A component(s) within the EnergySmart Dryer system has failed to stop after a system stop.	Determine which component(s) within the EnergySmart Dryer system did not stop and troubleshoot the component(s).
System Cool Down Done	The EnergySmart Dryer system has properly cooled down before shutting down.	This is a normal operating condition.
Dryer Blower Comms Read Error	The variable frequency drive (VFD) on the dryer has been turned off. Faulty wiring. Device did not accept the command. Incorrect Modbus address.	Turn on the variable frequency drive (VFD). Diagnose and correct wiring problems. Refer to the wiring diagrams supplied with the EnergySmart Drying System. Check the baud rate, data bits, parity and stop bits (9600, 8, N, 1). Correct the Modbus address. <i>See Operation section entitled, EnergySmart Dryer System Modbus Communications.</i>

Passive Alarms

If an alarm occurs, a red dialog box is displayed on the dryer’s touch screen control. The dryer continues to operate, but this problem could prevent correct drying of your material. The dialog box will indicate whether the alarm is a shut down alarm or a passive alarm.

Problem	Possible cause	Solution
Dry Air GasTrac TC Comms Read Error	The GasTrac Heater has been turned off.	Turn on the GasTrac Heater.
	Faulty wiring.	Diagnose and correct wiring problems. Refer to the wiring diagrams supplied with the EnergySmart Drying System.
	Device did not accept the command.	Check the baud rate, data bits, parity and stop bits (9600, 8, N, 1).
	Incorrect Modbus address.	Correct the Modbus address. <i>See Operation section entitled, EnergySmart Dryer System Modbus Communications.</i>
Dry Air GasTrac Burner Control Comms Read Error	The GasTrac’s Honeywell Burner control is has been turned off.	Turn on the burner control.
	Faulty wiring.	Diagnose and correct wiring problems. Refer to the wiring diagrams supplied with the EnergySmart Drying System.
	Device did not accept the command.	Check the baud rate, data bits, parity and stop bits (9600, 8, N, 1).
	Incorrect Modbus address.	Correct the Modbus address. <i>See Operation section entitled, EnergySmart Dryer System Modbus Communications.</i>

Passive Alarms

If an alarm occurs, a red dialog box is displayed on the dryer's touch screen control. The dryer continues to operate, but this problem could prevent correct drying of your material. The dialog box will indicate whether the alarm is a shut down alarm or a passive alarm.

Problem	Possible cause	Solution
Dry Air Heat Booster Comms Error on Read	The Hopper Temperature Controller (HTC) has been turned off.	Turn on the Hopper Temperature Controller (HTC).
	Faulty wiring.	Diagnose and correct wiring problems. Refer to the wiring diagrams supplied with the EnergySmart Drying System.
	Device did not accept the command.	Check the baud rate, data bits, parity and stop bits (9600, 8, N, 1).
	Incorrect Modbus address.	Correct the Modbus address. <i>See Operation section entitled, EnergySmart Dryer System Modbus Communications.</i>
Dry Air GasTrac TC Set Point Write Error	The GasTrac's temperature controller is turned off.	Turn on the GasTrac's temperature controller.
	Faulty wiring.	Diagnose and correct wiring problems. Refer to the wiring diagrams supplied with the EnergySmart Drying System.
	Device did not accept the command.	Check the baud rate, data bits, parity and stop bits (9600, 8, N, 1).
	Incorrect Modbus address.	Correct the Modbus address. <i>See Operation section entitled, EnergySmart Dryer System Modbus Communications.</i>

Passive Alarms

If an alarm occurs, a red dialog box is displayed on the dryer's touch screen control. The dryer continues to operate, but this problem could prevent correct drying of your material. The dialog box will indicate whether the alarm is a shut down alarm or a passive alarm.

Problem

Dry Air Heat Booster Set Point Write Error

Possible cause

The Hopper Temperature Controller (HTC) has been turned off.

Faulty wiring.

Device did not accept the command.

Incorrect Modbus address.

Solution

Turn on the Hopper Temperature Controller (HTC).

Diagnose and correct wiring problems. Refer to the wiring diagrams supplied with the EnergySmart Drying System.

Check the baud rate, data bits, parity and stop bits (9600, 8, N, 1).

Correct the Modbus address. *See Operation section entitled, EnergySmart Dryer System Modbus Communications.*

Passive Alarms

If an alarm occurs, a red dialog box is displayed on the dryer's touch screen control. The dryer continues to operate, but this problem could prevent correct drying of your material. The dialog box will indicate whether the alarm is a shut down alarm or a passive alarm.

Problem

Primary Vacuum Pump Overload - If the primary vacuum pump exceeds its full load amp rating or the overload has tripped due to a mechanical or electrical problem the dryer will shut down.

Possible cause

The vacuum pump current draw has exceeded the full load amps rating of the motor.

The vacuum has mechanically failed or is unable to rotate freely.

The vacuum pump has failed electrically.

Loss of phase of power to the motor starter.

The overload is set incorrectly.

The overload is defective.

Solution

Press alarm acknowledge and allow the overload to reset then try to restart the dryer. If the alarm condition occurs again have a qualified electrician check the current draw to the motor.

Disconnect and lock out main power. Check the vacuum pump for mechanical failure and free rotation. Replace if necessary. Allow the overload to reset then try to restart the dryer.

Disconnect and lock out main power. Check the vacuum pump for electrical shorts or open circuits. Replace if necessary. Allow the overload to reset then try to restart the dryer.

Check for a blown fuse in the dryer or main power supply. Allow the overload to reset then try to restart the dryer.

Disconnect and lock out main power. Check the overload settings and confirm that the settings match the full load amps listed on the vacuum pump motor. Allow the overload to reset then try to restart the dryer.

Replace the overload.

Passive Alarms

If an alarm occurs, a red dialog box is displayed on the dryer's touch screen control. The dryer continues to operate, but this problem could prevent correct drying of your material. The dialog box will indicate whether the alarm is a shut down alarm or a passive alarm.

Problem

Secondary Vacuum Pump Overload - If the primary vacuum pump exceeds its full load amp rating or the overload has tripped due to a mechanical or electrical problem the dryer will shut down.

Possible cause

The vacuum pump current draw has exceeded the full load amps rating of the motor.

The vacuum has mechanically failed or is unable to rotate freely.

The vacuum pump has failed electrically.

Loss of phase of power to the motor starter.

The overload is set incorrectly.

The overload is defective.

Solution

Press alarm acknowledge and allow the overload to reset then try to restart the dryer. If the alarm condition occurs again have a qualified electrician check the current draw to the motor.

Disconnect and lock out main power. Check the vacuum pump for mechanical failure and free rotation. Replace if necessary. Allow the overload to reset then try to restart the dryer.

Disconnect and lock out main power. Check the vacuum pump for electrical shorts or open circuits. Replace if necessary. Allow the overload to reset then try to restart the dryer.

Check for a blown fuse in the dryer or main power supply. Allow the overload to reset then try to restart the dryer.

Disconnect and lock out main power. Check the overload settings and confirm that the settings match the full load amps listed on the vacuum pump motor. Allow the overload to reset then try to restart the dryer.

Replace the overload.

Passive Alarms

If an alarm occurs, a red dialog box is displayed on the dryer's touch screen control. The dryer continues to operate, but this problem could prevent correct drying of your material. The dialog box will indicate whether the alarm is a shut down alarm or a passive alarm.

Problem	Possible cause	Solution
<p>Primary Loader No Material Alarm - The demand sensor located at the optional material receiver has not been satisfied after three (3) attempts.</p>	<p>The sensor is not adjusted properly.</p> <p>No material is being conveyed.</p> <p>The conveying load time is too short.</p> <p>Conveying blower is not coming on.</p> <p>The conveying filter is clogged.</p> <p>Hoses have come off or are loose in the conveying loop.</p> <p>The air operated valves are not operating.</p>	<p>Adjust the sensor as needed.</p> <p>Check material supply.</p> <p>Increase the load time setpoint.</p> <p>Check the blower fuses in the control and the overload settings.</p> <p>Clean or replace the conveying filter.</p> <p>Check for loose hoses and make sure all hose clamps are secure.</p> <p>Make sure compressed air is connected and that the solenoid valves are operating properly.</p>
<p>Secondary Loader No Material Alarm - The demand sensor located at the optional material receiver has not been satisfied after three (3) attempts.</p>	<p>The sensor is not adjusted properly.</p> <p>No material is being conveyed.</p> <p>The conveying load time is too short.</p> <p>Conveying blower is not coming on.</p> <p>The conveying filter is clogged.</p> <p>Hoses have come off or are loose in the conveying loop.</p> <p>The air operated valves are not operating.</p>	<p>Adjust the sensor as needed.</p> <p>Check material supply.</p> <p>Increase the load time setpoint.</p> <p>Check the blower fuses in the control and the overload settings.</p> <p>Clean or replace the conveying filter.</p> <p>Check for loose hoses and make sure all hose clamps are secure.</p> <p>Make sure compressed air is connected and that the solenoid valves are operating properly.</p>

Passive Alarms

If an alarm occurs, a red dialog box is displayed on the dryer’s touch screen control. The dryer continues to operate, but this problem could prevent correct drying of your material. The dialog box will indicate whether the alarm is a shut down alarm or a passive alarm.

Problem	Possible cause	Solution
Process Material Temperature High	Process material temperature setpoint is above the alarm setpoint. The drying monitor probe is not accurately reading the temperature.	Increase the process material temperature alarm setpoint if it is too close to the delivery temperature setpoint. Replace the drying monitor probe.
Process Material Temperature Low	Process material temperature setpoint is below the alarm setpoint. The drying monitor probe is not accurately reading the temperature.	Decrease the process material temperature alarm setpoint if it is too close to the delivery temperature setpoint. Replace the drying monitor probe.
Dry Air GasTrac General Alarm	The GasTrac is not operating properly.	<i>Refer to the GasTrac’s manual for troubleshooting.</i>
Dry Air Electrical Heat Booster General Alarm	The Hopper Temperature Controller (HTC) is not operating properly.	<i>Refer to the Hopper Temperature Controller’s (HTC’s) manual for troubleshooting.</i>
Dry Air Process Flow Sensor Alarm	The flow sensor is damaged or not functioning properly. Faulty wiring.	Replace the flow sensor. Diagnose and correct wiring problems. Refer to the wiring diagrams supplied with the EnergySmart Drying System.

Passive Alarms

If an alarm occurs, a red dialog box is displayed on the dryer's touch screen control. The dryer continues to operate, but this problem could prevent correct drying of your material. The dialog box will indicate whether the alarm is a shut down alarm or a passive alarm.

Problem	Possible cause	Solution
Dry Air Process Pressure Sensor Alarm	The pressure sensor is damaged or not functioning properly. Faulty wiring.	Replace the pressure sensor. Diagnose and correct wiring problems. Refer to the wiring diagrams supplied with the EnergySmart Drying System.
Return Air Dew Point Sensor Alarm	The dew point sensor is damaged or not functioning properly.	Replace the dew point sensor. Diagnose and correct wiring problems. Refer to the wiring diagrams supplied with the EnergySmart Drying System.

Passive Alarms

If an alarm occurs, a red dialog box is displayed on the dryer's touch screen control. The dryer continues to operate, but this problem could prevent correct drying of your material. The dialog box will indicate whether the alarm is a shut down alarm or a passive alarm.

Problem	Possible cause	Solution
<p>Drying Monitor High Temperature (T1-T6) - One or more RTD probes located at positions T1 through T6 on the drying monitor are above the maximum temperature setpoint.</p>	Material throughput is too low.	Ensure the material usage is within the rated capacity of the dryer and hopper in the system.
	Material level in the hopper is above the selected High Temperature Alarm RTD.	Check your material supply system for receiver problems, material availability, etc.
	Process air is not at the proper drying temperature.	Reduce the process air temperature entering the hopper.
	The process temperature setpoint and the DM-II setpoints are not the same.	Determine which setpoint is incorrect and adjust as needed.
<p>Drying Monitor Low Temperature (T1-T6) - One or more RTD probes located at positions T1 through T6 on the drying monitor are above the maximum temperature setpoint.</p>	Material throughput is too high.	Ensure the material usage is within the rated capacity of the dryer and hopper in the system.
	Material level in the hopper is below the selected High Temperature Alarm RTD.	Check your material supply system for receiver problems, material availability, etc.
	Process air is not at the proper drying temperature.	Check for process deviation or loop break alarms on the dryer control, correct drying temperature.
	The process temperature setpoint and the DM-II setpoints are not the same.	Determine which setpoint is incorrect and adjust as needed.
	Poor air flow to the hopper.	<p>Clean or replace the all filters in the process air stream.</p> <p>Verify if the precess blow is operating properly, including rotation.</p> <p>Straighten crimps or remove any debris that may restrict air flow through hoses and turbes</p>

Dew Point Troubleshooting

Under normal operating conditions, the dryer will produce Dew points in the range of -40 to -20° F {-40 to -29° C}. However, you may experience situations that produce undesirable results.

Problem

Dryer not producing desired dew point.

Possible cause

Low regeneration air flow.

Return air temperature exceeds 125°F {52°C}.

Regeneration temperature is below normal setting.

Leaks in process lines.

Contaminated desiccant due to off-gassing, too long of a residence time or drying temperature is too high for the grade of material being processed.

Analog option board/sensor malfunction

Solution

Check regeneration filter and clean and/or replace as necessary.

Reduce the temperature of the cooling water or increase the flow.

Connect water to the aftercooler/intercooler if not already connected.

Check for adequate water temperature. Water temperature should be approximately 85°F {29°C}.

Check amperage of regeneration heaters. Replace heaters if necessary.



WARNING: Any electrical checks should be performed by a qualified electrician.

Check all hoses, gaskets, doors, loaders or other potential areas where leakage may occur. Replace any defective hoses or gaskets.

Verify proper drying temperatures and residence times. If off-gassing is a condition of the material being processed, contact Conair Parts at (800) 458 1960 for the addition of a volatile trap.

Verify dryer dew point readings with a calibrated portable dew point meter.

Replace analog option board or sensor.

Poor Material Drying Troubleshooting

Occasionally, processing problems that are suspected of being caused by poor drying are eventually determined to be the result of other issues in the process setup. The intent of the information provided here is to assist you in determining if your drying system is performing properly. However, the only way to know definitely if your material is properly dried is to perform moisture analysis of small samples as it leaves the bottom of the hopper, or just as it enters the process. Conair does not sell moisture-analyzing equipment, but there are many brands of this equipment available on the market.

You should also be aware that some processing problems may actually be the result of over-drying material. Most materials will degrade to some extent if they are exposed to their specified drying temperature for a time significantly longer than the residence time specified by the supplier. If you want to maintain its dryness, it is recommended that you reduce the process air temperature. If your Conair dryer is equipped with the Setback feature, you should familiarize yourself with it, and make use of it. If not, you may want to contact Conair to determine if it can be added to your dryer.

A majority of customer questions to Conair are related to dew point. It is important to realize that dew point is one of **four** requirements that need to be satisfied.

There are four requirements, listed in order of importance, necessary to properly dry hygroscopic plastic resins:

- 1 Drying temperature** of the air entering the hopper must be at the proper drying temperature for your material, as specified by your material supplier.
- 2 Residence time** is the time, determined by your material supplier, that the material in use must be heated to achieve proper drying temperature.
- 3 Air flow** during the process drying circuit must be adequate to carry and distribute the heat throughout the entire bed of material inside the hopper.
- 4 Dew point** of the process air must be low so it can efficiently collect the moisture as it is released from the heated material and carry it to the dryer to be removed in the desiccant.



NOTE: Concerns with drying temperature may require review of HTC or GasTrac controls.

Poor Material Drying Troubleshooting (continued)

Once it is determined which of the four requirements that is not being satisfied, refer to the following list of possible causes and solutions.

 **NOTE:** Concerns with drying temperature may require review of HTC or GasTrac controls.

Temperature - The temperature of the air entering the hopper must be at the proper drying temperature for your material, as specified by your supplier.

Problem	Possible cause	Solution
<p>The temperature of the air entering the hopper is not at proper drying temperature.</p>	<p>Incorrect setpoint</p>	<p>Refer to the drying specifications for your material and adjust the setpoint to the recommended setpoint.</p> <p>If your dryer has the Setback option, make sure it is not active unless you have specifically activated it. If necessary, refer to the Operation section of this manual for assistance in using the Setback function.</p>
	<p>Not able to achieve setpoint.</p>	<p>Replace any defective process heater, contactors, fuses, etc.</p> <p>Ensure the selected drying temperature is within the design specifications of your dryer.</p>
	<p>Inaccurate process temperature readout.</p>	<p>Ensure the Process RTD is properly positioned in the air stream.</p> <p>Determine if there is a problem in the temperature control circuit and repair or replace any defective components such as RTD, temperature control, circuit boards, etc.</p>

Poor Material Drying Troubleshooting (continued)

Residence Time - The time your material supplier has determined that the material in use must be heated to its drying temperature to achieve proper drying.

Problem	Possible cause	Solution
Material residence time is too long or short.	Material level in hopper is too low.	Make sure there is an adequate supply of material to feed the loader on top of the drying hopper. Correct any problems with the conveying system that may be preventing your loader from filling the hopper. If your hopper has a level sensor for maintaining a material level less than completely full, be sure this sensor is adjusted properly.
	Material throughput is too high.	Take any necessary steps, such as slowing down the process, to ensure the material usage is within design specifications of the dryer and hopper.

Poor Material Drying Troubleshooting (continued)

Air flow - The air flow in the process drying circuit must be adequate to carry and distribute the heat throughout the entire bed of material inside the hopper. If the air flow is too low, the material in the center of the hopper may get heated fully to the drying temperature, but the material against the sidewalls will not. In most cases, the material 2/3 to 3/4 of the way toward the top of the hopper should be heated to the proper drying temperature.

Problem

Too much or too little air flow.



NOTE: If there is too much air flow, the material may fluidize inside the hopper, resulting in inconsistent material flow through the hopper, which can negatively impact residence time.

Possible cause

Dirty process air filter.

Collapsed hoses or holes/leaks in the hoses and hose connection.

Air flow restrictions.

Process blower running backwards or performing poorly.

Material level in the hopper too low.

Solution

Clean or replace the process filter.

Replace any worn or damaged hoses. Tighten all hose clamps to eliminate leaks.

Remove any obstructions in the process air circuit.

Verify the process blower is running in the correct direction. If backwards, reverse direction by switching any 2 legs of high voltage to the motor.



WARNING: Any electrical checks should be performed by a qualified electrician.

Repair or replace motor.

Other than running out of material to complete a job, the material level inside the hopper must be a minimum of 50% full. If the hopper is not at least half full, the material in the cone section will not get adequate air flow to dry properly.

Replacement dew point monitors are available from Conair.

Contact Conair Parts
(800) 458 1960
From outside of the United States, call:
(814) 437 6861

Poor Material Drying Troubleshooting (continued)

Dew point - The process air must be at a low dew point so it can efficiently collect the moisture as it is released from the heated material and carry it to the dryer to be removed in the desiccant. In most cases, the dryer will dry your material satisfactorily if the dew point of the air is -20 to -40° F {-29 to -40° C}. If your dryer does not have a dew point readout, you can check the dew point with a portable dew point instrument. Conair sells a variety of portable dew point meters. Contact Conair

Problem	Possible cause	Solution
Dryer dew point is not reaching proper setpoint.	Low regeneration temperature.	Replace or check defective heaters, fuses etc.
	Poor regeneration air flow.	Clean or replace the regeneration filter. Ensure the regeneration blower is operating properly and rotating in the correct direction. <i>See Installation section entitled, Checking for proper air flow.</i>
	High dew point, ambient air leaking into the closed loop drying circuit.	Remove obstructions in the air stream, such as crimped hoses, etc. Replace damaged hoses and seal any leaks in the process air circuit. If using a vacuum loader on the hopper, ensure that the loader shroud is installed in the hopper and that the hopper is completely filled with material. If partially filling your hopper, ensure that the hopper loader is sealed against ambient air. Install a gasket between the loader and the top of the hopper.
	Return air temperature to the dryer is too high. (The return air temperature on W1600-5000 dryers is measured at the inlet to the desiccant wheel.)	Clean the aftercooler/intercooler coils. <i>See Maintenance section entitled, Cleaning the aftercooler/intercooler coils.</i>
	Poor desiccant performance.	<i>See Troubleshooting section entitled, Replacing the desiccant wheel assembly.</i>

Replacing Fuses

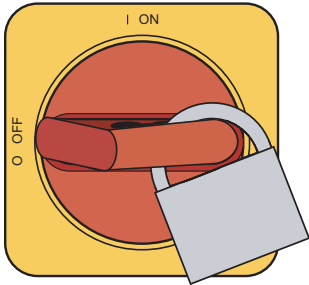

IMPORTANT: Always refer to the wiring diagrams that came with your dryer to locate specific electrical components. Illustrations in the User Guide are intended to be representative only.

1 Disconnect and lockout the main power supply. 

2 Open the electrical enclosure door.

3 Check the fuse with an ohmmeter. If necessary, pull the fuse out and replace it with a fuse of the same type and rating.

Fuse Blocks

To locate the appropriate fuse and replacement part, refer to the wiring diagrams that came with your dryer.



Checking Heater Solid State Relays



CAUTION: Always disconnect and lock out the main power sources before making electrical connections. Electrical connections should be made only by qualified personnel.

- 1 Disconnect and lockout the main power supply.
- 2 Open the electrical enclosure.
- 3 Locate the regeneration solid state relays. Refer to the wiring diagrams that came with your dryer.

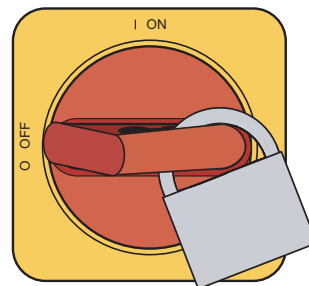

IMPORTANT: Always refer to the wiring diagrams that came with your dryer to locate specific electrical components. Illustrations in the User Guide are intended to be representative only.

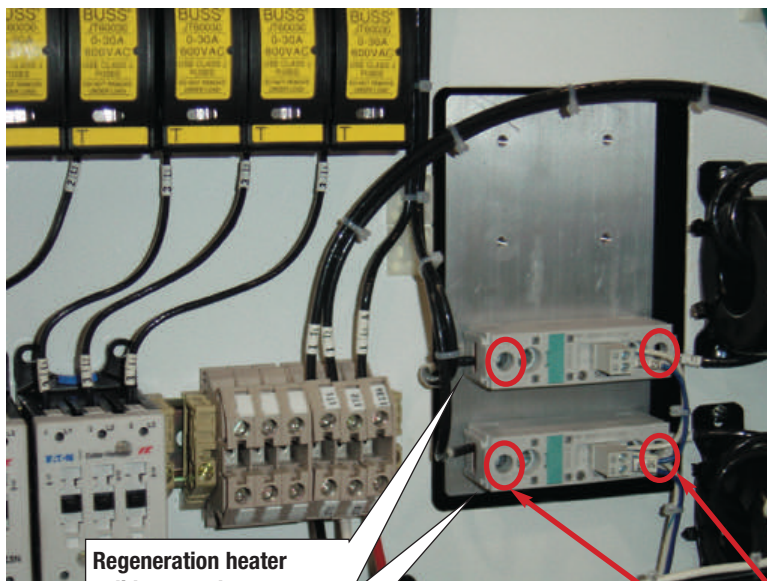

Regeneration heater solid state relays

- 4 Turn power on to the machine.
- 5 Start the dryer.
- 6 Measure voltage across the high voltage connections using a voltmeter. When relay is energized, as indicated by the LED (green) voltage should be read 0 (zero). When relay is de-energized, LED off, full voltage should be measured across the relay. When relay is off, if voltage reads zero, relay is bad and needs replaced. Repeat this procedure for each relay.



NOTE: Measure voltage using a voltmeter across the two high voltage connections of each relay. (Shown here circled in red.)



IMPORTANT: Always refer to the wiring diagrams that came with your dryer to locate specific electrical components. Illustrations in the User Guide are intended to be representative only.

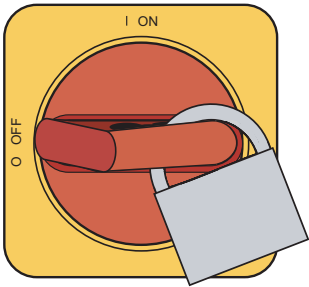

Checking or Replacing Temperature Sensors



The Carousel Plus W Series Dryer uses RTD sensors to monitor the temperatures of the return air, the regeneration outlet, and the regeneration inlet.

To check or replace an RTD sensors:

- 1 Disconnect and lockout the main power supply.** 
- 2 Remove dryer panels, as necessary.** *See Installation section entitled, [Opening the dryer doors \(W1600-5000\)](#).*
- 3 Locate the RTD sensors.**
- 4 Check the sensor positions and conditions.** Temperature readings will be incorrect, if the sensors are touching the wall of an air hose or pipe or if the sensor or wiring is damaged. The tip of the sensor should be centered within the air hose or pipe. Sensor wires should be attached to the appropriate connection points on the dryer's electrical enclosure or microprocessor board.
- 5 To check with ohm meter,** measure the resistance across the RTDs. The resistance should be approximately 110 ohm at room temperature.
- 6 Replace the sensor, if necessary.**

Replacing the Desiccant Wheel Assembly (w600 - 1000)

When desiccant becomes clogged or contaminated, you should replace the desiccant wheel to ensure optimum performance.

- 1 Stop the dryer, disconnect the power, and follow proper lockout procedures.** 
- 2 Remove the upper and lower side panels from both sides of the dryer.** 
- 3 Remove the top cover from the dryer by removing the securing bolts.**
- 4 Note the position of all the hoses, RTDs, and wiring connections then remove or disconnect these from the desiccant wheel assembly.**
- 5 If the dryer aftercooler is being used, turn off the water supply to the aftercooler and disconnect the water lines from the aftercooler.**
- 6 Remove the bolts securing the aftercooler assembly to the desiccant wheel assembly.**
- 7 Remove the bolts securing the desiccant wheel assembly in the dryer frame.**
- 8 If the dryer aftercooler is being used, slide the desiccant wheel assembly towards the front of the dryer, being careful not to let it fall off the dryer frame. Unbolt the aftercooler assembly from the back panel of the dryer and remove it.** 
- 9 Note the orientation of the desiccant wheel assembly. Using an overhead crane or similar device, use the lifting rings provided and lift the desiccant wheel assembly out of the dryer.**

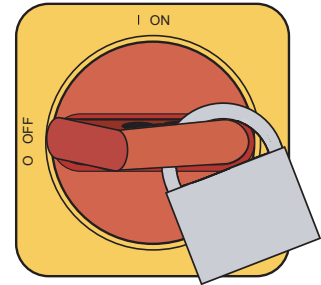



Replacing the Desiccant Wheel Assembly (W600 - 1000) (continued)



- 10** Lift the new desiccant wheel into the dryer frame, being sure it is oriented properly. To verify the correct orientation, ensure that the regeneration air inlet is positioned closest to the regeneration heater tube. **DO NOT** bolt into place at this time.
- 11** If the dryer aftercooler is being used, slide the desiccant wheel assembly towards the front of the dryer, being careful to not let it slip off one side of the dryer frame. Position the aftercooler assembly into the dryer frame and bolt it to the rear panel.
- 12** Position the desiccant wheel assembly and bolt it in place.
- 13** Bolt the aftercooler to the desiccant wheel assembly.
- 14** If the aftercooler is being used, reconnect the water lines.
- 15** Reconnect or reinstall all hoses, RTDs, and wiring connections.
- 16** Bolt the top cover in place.
- 17** Connect the power to the dryer and start it. Ensure that the desiccant wheel assembly rotates in the correct direction.
- 18** Replace all upper and lower side panels.

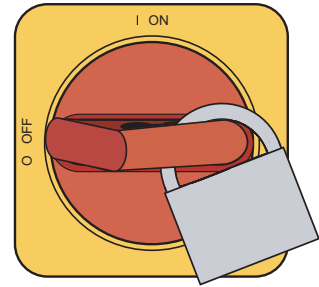

Replacing the Desiccant Wheel Motor (w600 - 1000)

- 1 Stop the dryer, disconnect and lockout the main power.** 
- 2 Remove both side panels.** 
- 3 Disconnect wiring to the motor.**
- 4 Remove the pivot bolt securing the belt tensioner to the motor bracket.** Be sure to retain the flat washers located between the tensioner and bracket. Disconnect the spring and remove the tensioner.
- 5 Remove the belt from the motor pulley, then remove the pulley from the motor.**
- 6 Remove the screws securing the motor to the upper and lower bracket, and remove the motor.**
- 7 Secure the new motor to the bracket.**
- 8 Install the pulley on the new motor, and position the belt on the pulley.**
- 9 Connect the spring to the tensioner, then secure the tensioner to the motor bracket.** Be sure to install flat washers between the motor bracket and the tensioner.
- 10 Connect the wires to the motor.**
- 11 Connect the power to the dryer.** Turn the dryer on and ensure that the desiccant wheel is rotating in the correct direction.
- 12 Replace the side panels.**

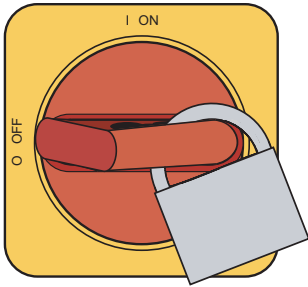



Replacing the Desiccant Wheel Motor (W1600 - 5000)

- 1 Stop the dryer, disconnect and lockout the main power.** 
- 2 Open the right side panel(s), as viewed from the front of the dryer.** 
See Installation section entitled, Opening the dryer doors (W1600-5000).
- 3 Unbolt and remove the access panel on the side of the desiccant wheel assembly.**
- 4 Disconnect the wiring connection to the motor.**
- 5 While noting the number of turns, relieve the tension on the drive bolt by loosening the nut above the tension spring until the belt can be slipped off the motor sprocket.**
- 6 Unbolt the motor and remove it from its mounting bracket.**
- 7 Remove the sprocket from the old motor, and install it onto the new motor.**
- 8 Bolt the new motor in place.** Be sure to remove the plastic plug in the vent hole of the gearbox.

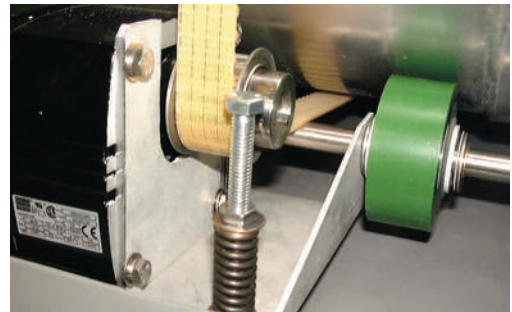
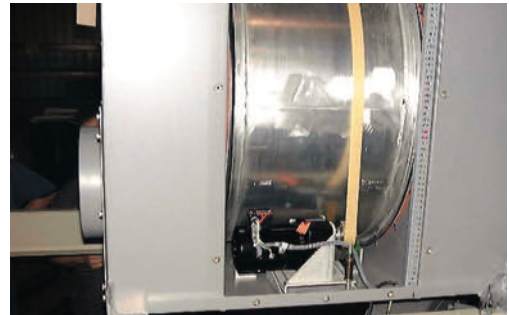

Replacing the Desiccant Wheel Motor (W1600 - 5000) (continued)

- 9** Slip the belt onto the sprocket, and adjust the tension spring nut to its original position.
- 10** Connect the wires to the new motor.
- 11** With the access panel still removed, connect the power to the dryer and start it. Ensure the wheel turns in the correct direction. If the belt appears to be slipping, it may be necessary to increase the tension on the drive belt slightly. Do not increase this tension any more than necessary to allow the wheel to rotate without slipping.
- 12** Bolt the access panel in place and close the side panel(s) on the dryer.

Additional manuals and prints for your Conair equipment may be ordered through the Customer Service or Parts Department for a nominal fee. Most manuals can be downloaded free of charge from the product section of the Conair website.
www.conairgroup.com

We're Here to Help

Conair has made the largest investment in customer support in the plastics industry. Our service experts are available to help with any problem you might have installing and operating your equipment. Your Conair sales representative also can help analyze the nature of your problem, assuring that it did not result from misapplication or improper use.

How to Contact Customer Service

To contact Customer Service personnel, call:



 **NOTE:** Normal operating hours are 8:00 am - 5:00 pm (EST). After hours emergency service is available at the same phone number.

You can commission Conair service personnel to provide on-site service by contacting the Customer Service Department.

Before You Call...

If you do have a problem, please complete the following checklist before calling Conair:

- Make sure you have all model, control type and serial numbers from the serial tag, and parts list numbers for your particular equipment. Service personnel will need this information to assist you..
- Make sure power is supplied to the equipment.
- Make sure that all connectors and wires within and between control systems and related components have been installed correctly.
- Check the troubleshooting guide of this manual for a solution.
- Thoroughly examine the instruction manual(s) for associated equipment, especially controls. Each manual may have its own troubleshooting guide to help you.
- Check that the equipment has been operated as described in this manual.
- Check accompanying schematic drawings for information on special considerations.

Equipment Guarantee

Conair guarantees the machinery and equipment on this order, for a period as defined in the quotation from date of shipment, against defects in material and workmanship under the normal use and service for which it was recommended (except for parts that are typically replaced after normal usage, such as filters, liner plates, etc.). Conair's guarantee is limited to replacing, at our option, the part or parts determined by us to be defective after examination. The customer assumes the cost of transportation of the part or parts to and from the factory.

Performance Warranty

Conair warrants that this equipment will perform at or above the ratings stated in specific quotations covering the equipment or as detailed in engineering specifications, provided the equipment is applied, installed, operated and maintained in the recommended manner as outlined in our quotation or specifications.

Should performance not meet warranted levels, Conair at its discretion will exercise one of the following options:

- Inspect the equipment and perform alterations or adjustments to satisfy performance claims. (Charges for such inspections and corrections will be waived unless failure to meet warranty is due to misapplication, improper installation, poor maintenance practices or improper operation.)
- Replace the original equipment with other Conair equipment that will meet original performance claims at no extra cost to the customer.
- Refund the invoiced cost to the customer. Credit is subject to prior notice by the customer at which time a Return Goods Authorization Number (RGA) will be issued by Conair's Service Department. Returned equipment must be well crated and in proper operating condition, including all parts. Returns must be prepaid.

Purchaser must notify Conair in writing of any claim and provide a customer receipt and other evidence that a claim is being made.

Warranty Limitations

Except for the Equipment Guarantee and Performance Warranty stated above, Conair disclaims all other warranties with respect to the equipment, express or implied, arising by operation of law, course of dealing, usage of trade or otherwise, including but not limited to the implied warranties of merchantability and fitness for a particular purpose.

TouchView/ES1 Prints

Allen-Bradley

Siemens

Control Wiring

18866506	W600	18866606
18866507	W800	18866607
18866508	W1000	18866608
18866509	W1600	18866609
18866510	W2400	18866610
18866511	W3200	18866611
18866512	W5000	18866612

Modbus Comms wiring

18867001	Non-ES1	18867003
18867002	ES1	18867004

Interconnect wiring

18867010		18867010
----------	--	----------

ES1 VFD wiring

18866706	W600	18866806
18866707	W800	18866807
18866708	W1000	18866808
18866709	W1600	18866809
18866710	W2400	18866810
18866711	W3200	18866811
18866712	W5000	18866812

HTC wiring

18864008	HTC 15	18864008
18864009	HTC 30	18864009
18864010	HTC 60	18864010
18864011	HTC 90	18864011
18864012	HTC 120	18864012
18864013	HTC 180	18864013
18864014	HTC 270	18864014

Gas Trac Wiring

18858801	All sizes	18858801
----------	-----------	----------

What is the Conair Hard Piping Kit?

Conair's Hard Piping Kit is for use with your drying system. Conair recommends the hard pipe kit for line sizes of eight inches and larger. This kit is an upgrade over the standard flex hose.

Hard pipe kits are recommended because they:

- eliminate the possibility of sag or collapse, especially around corners where those are common issues with flex hose.
- eliminate the possibility of restricted air flow due to hose damage (collapse, puncture, leaking, moisture infiltration).
- minimize maintenance needs.
- create a more permanent finished appearance.
- reduce air flow drag due to the smooth interior surface.

For more information about adding a Conair Hard Pipe Kit to your drying system, contact Conair.

Conair's sales number is 724-584-5500.

Conair's Instant Access
24/7 Parts and Service number is 800-458-1960.
Outside the U.S., dial 814-437-6861.



How Does it Work?

Conair's Hard Piping Kit is a complete modular system. Each component utilizes a flanged end that is precision engineered to a perfect 90° angle to produce an accurate seal every time. The system utilizes simple to use clamp rings to quickly connect the components. This extremely strong and reliable connection system has been tested and approved for up to three bar shock explosion resistance.

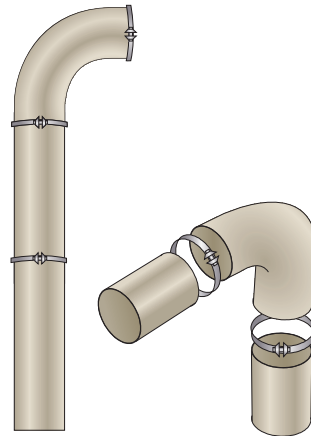

Unpacking the boxes

Your hard piping kit components will vary depending on which kit you ordered. Kits are often customized for each customer.

If your hard pipe kit was ordered as one of the standard kits, below is what you should expect to find when you unpack the boxes.

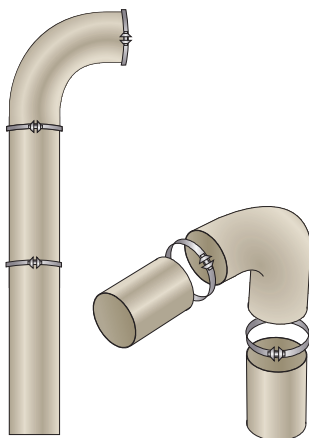

Conair Part #18090001: 8 inch Hard Pipe Basic Kit

- Seven (7) 8 inch 1D 90, 16 GA, coated CS (PN 2671310201)
- Two (2) welded tube, 8 inch x 78 inch, coated CS, 19 GA (PN 2671291001)
- Five (5) welded tube, 8 inch x 39 inch, coated CS, 19 GA (PN 2671290901)
- Five (5) welded tube, 8 inch x 20 inch, coated CS, 19 GA (PN 2671290801)
- Four (4) welded slip tube, 8 inch x 20 inch, coated CS, 19 GA (PN 2671330501)
- Two (2) welded slip tube, 8 inch x 8 inch, coated CS, 19 GA (PN 2671330401)
- Six (6) 8 inch slip tube ring seal (PN 26713202)
- Six (6) Conair flange adaptors (PN 18477901)
- Twenty-six (26) 8 inch bolted pull ring, galvanized (PN 2671350201)
- Twenty (20) 8 inch U-shaped gasket, 19 GA (PN 2671360201)
- Six (6) 8 inch Conair hard pipe gasket (PN 185107930)
- Six (6) 8 inch ceiling mount clamp, Galvanized, high-temp. (PN 2671390201)
- Forty-eight (48) 5/16-18NC x 1 inch hex head wiz lock cap screw (PN 21202504)
- Forty-eight (48) 516-18 hex head wiz lock nut (PN 22300804)
- Six (6) threaded rod, 3/8-16 x 10 feet long (60 feet total length) (PN 2190091004)
- Six (6) threaded rod adapter (PN 18598074)
- Six (6) hex head bolt, M10 x 1.5 x 15MM, plated (PN 21247302)
- Eighteen (18) washer, flat, 3/8 inch, plated (PN 22500302)

Conair Part #18090002: 12 inch Hard Pipe Basic Kit

- Two (2) 8 inch Conair hard pipe gasket (PN 185107930)
- Two (2) 8 inch hard pipe flange x 12 inch tubing adaptor (PN 18477910)
- Seven (7) 12 inch 1D 90, 16 GA, coated CS
- Three (3) welded tube, 12 inch x 78 inch, coated CS, 19 GA (PN 2671291501)
- Six (6) welded tube, 12 inch x 39 inch, coated CS, 19 GA (PN 2671291401)
- Six (6) welded tube, 12 inch x 20 inch, coated CS, 19 GA (PN 2671291301)
- Four (4) welded slip tube, 12 inch x 20 inch, coated CS, 19 GA (PN 2671330901)
- Two (2) welded slip tube, 12 inch x 8 inch, coated CS, 19 GA (PN 2561330701)
- Six (6) 12 inch slip tube ring seal (PN 26713203)
- Six (6) 12 inch Conair flange to 12 inch adapter (PN 18477902)
- Twenty-nine (29) 12 inch bolted pull ring, galvanized (PN 2671350301)
- Twenty-three (23) 12 inch U-shaped gasket, 19 GA (PN 2671360301)
- Six (6) 12 inch Conair hard pipe gasket (PN 185107916)
- Six (6) 12 inch ceiling mount clamp, galvanized, high-temp (PN 2671390301)
- Sixty-four (64) 5/16-18NC x 1 inch hex head wiz lock cap screw (PN 21202504)
- Sixty-four (64) 516-18 hex head wiz lock nut (PN 22300804)
- Six (6) threaded rod, 3/8-16 x 10 feet long (60 feet total length) (PN 2190091004)
- Six (6) threaded rod adapter (PN 18598074)
- Six (6) hex head bolt, M10 x 1.5 x 15MM, plated (PN 21247302)
- Eighteen (18) washer, flat, 3/8 inch, plated (PN 22500302)

Unpacking the boxes (continued)

Conair Part #18090003: 8 inch Hard Pipe GT Kit

- Two (2) 8 inch 1D 90, 16 GA, coated CS (PN 2671310201)
- One (1) welded tube, 8 inch x 78 inch, coated CS, 19 GA (PN 2671291001)
- One (1) welded tube, 8 inch x 39 inch, coated CS, 19 GA (PN 2671290901)
- One (1) welded tube, 8 inch x 20 inch, coated CS, 19 GA (PN 2671290801)
- One (1) welded slip tube, 8 inch x 39 inch, coated CS, 19 GA (PN 2671330601)
- One (1) welded slip tube, 8 inch x 20 inch, coated CS, 19 GA (PN 2671330501)
- One (1) welded slip tube, 8 inch x 8 inch, coated CS, 19 GA (PN 2671330401)
- Three (3) 8 inch slip tube ring seal (PN 26713202)
- One (1) Conair flange adaptors (PN 18477901)
- Nine (9) 8 inch bolted pull ring, galvanized (PN 2671350201)
- Six (6) 8 inch U-shaped gasket, 19 GA (PN 2671360201)
- Two (2) 8 inch hose, high temp (PN 2400071002)
- One (1) 8 inch Conair hard pipe gasket (PN 185107930)
- Four (4) 8 inch hose clamps (PN 24900124)
- Six (6) 8 inch insulation (PN 25902417)
- One (1) 8 inch 90° insulation (PN 18195701)
- Eight (8) 5/16-18NC x 1 inch hex head wiz lock cap screw (PN 21202504)
- Eight (8) 516-18 hex head wiz lock nut (PN 22300804)
- Twenty-five (25) feet of 3 inch ASJ SSL insulation tape (PN 25910404) (insulation)

For more information about adding a Conair Hard Pipe Kit to your drying system, contact Conair.

Conair's sales number is 724-584-5500.

Conair's Instant Access 24/7 Parts and Service number is 800-458-1960. Outside the U.S., dial 814-437-6861.

Conair Part #18090004: 12 inch Hard Pipe GT Kit

- Two (2) 8 inch hose connection, coated CS, 19 GA (PN 2671400201)
- Two (2) 8 inch hose, high temp (PN 2400071002)
- Two (2) 8 inch Conair hard pipe gasket (PN 185107930)
- Two (2) 8 inch hard pipe flange x 12 inch tubing adaptor (PN 18477910)
- Four (4) 8 inch hose clamps (PN 24900124)
- Two (2) 12 inch 1D 90, 16 GA, coated CS
- One (1) welded tube, 12 inch x 78 inch, coated CS, 19 GA (PN 2671291501)
- One (1) welded tube, 12 inch x 39 inch, coated CS, 19 GA (PN 2671291401)
- One (1) welded tube, 12 inch x 20 inch, coated CS, 19 GA (PN 2671291301)
- One (1) welded slip tube, 12 inch x 20 inch, coated CS, 19 GA (PN 2671330901)
- One (1) welded slip tube, 12 inch x 39 inch, Coated CS, 19 GA (PN 2671331001)
- One (1) welded slip tube, 12 inch x 8 inch, coated CS, 19 GA (PN 2561330701)
- Three (3) 12 inch slip tube ring seal (PN 26713203)
- One (1) 12 inch Conair flange to 12 inch adapter (PN 18477902)
- Nine (9) 12 inch bolted pull ring, galvanized (PN 2671350301)
- Six (6) 12 inch U-shaped gasket, 19 GA (PN 2671360301)
- Two (2) 12 inch hose connection, coated CS, 19 GA (PN 2671400301)
- One (1) 12 inch Conair hard pipe gasket (PN 185107916)
- Six (6) 12 inch insulation (PN 25902418)
- Two (2) 12 inch hose, high temp (PN 2400071102)
- Four (4) 12 inch hose clamps (PN 24900126)
- One (1) 12 inch 90° insulation (PN 18195702)
- Twenty-four (24) 5/16-18NC x 1 inch hex head wiz lock cap screw (PN 21202504)
- Twenty-four (24) 516-18 hex head wiz lock nut (PN 22300804)
- Twenty-five (25) feet of 3 inch ASJ SSL insulation tape (PN 25910404)
- One (1) 8 inch hard pipe flange x 12 inch tubing adaptor (PN 1847791001)

Preparing for installation

Your plant layout and drying system component positioning will determine the organization of pieces necessary to complete the piping between the dryer and hopper. Each application will vary. Conair recommends that you take the following steps before starting installation.

For more information about adding a Conair Hard Pipe Kit to your drying system, contact Conair.

Conair's sales number is 724-584-5500.

Conair's Instant Access 24/7 Parts and Service number is 800-458-1960. Outside the U.S., dial 814-437-6861.

1 Organize all like pieces. Place all clamps together, all straight sections together, all elbows together, etc.

2 Start by laying the pieces out between the dryer and the hopper. If you ordered your hard pipe kit as part of a Conair system, a system drawing may have been included that will indicate pipe position and suggested layout.

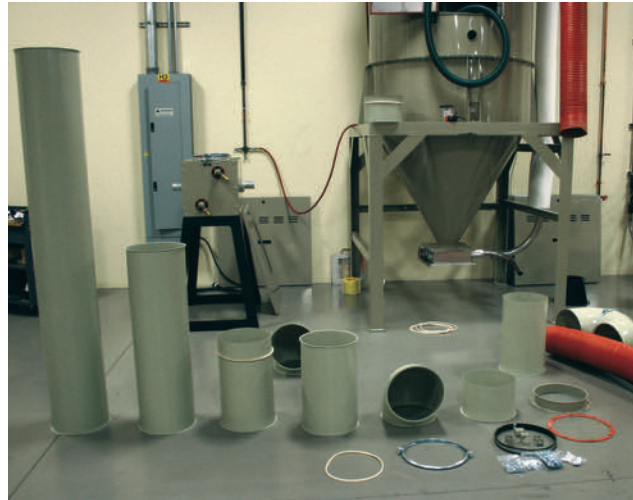

3 Visually inspect to make sure that the pieces you have will meet the needs of your system. If it looks like you will need additional pieces to complete your system, contact Conair Parts and Service. You can order individual pieces as necessary to complete your system.



4 If your drying system has been in use, wait until all components have cooled prior to attempting any installation steps.



CAUTION: Hot surfaces. Always protect yourself from hot surfaces inside and outside the dryer and drying hopper.

Using Pull Ring Connections

The following are general usage instructions for pull-ring connections with U-shaped seals. This is the primary style of connection used with Conair hard pipe kits.

1 Pull the U-shaped seal around one of the pipe flanges. The seal can be stretched to fit, but avoid overstretching.

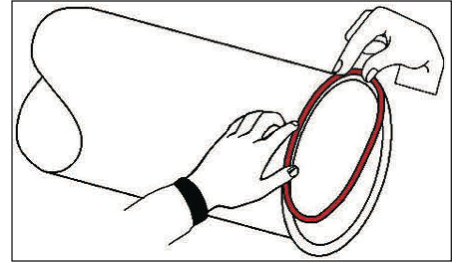

2 Make sure that the “tooth” side of the U-shaped seal will face the pipe section that will be connected to this one.

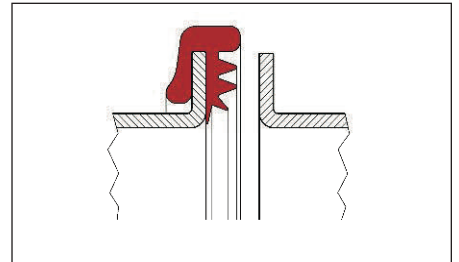

3 Place the next section (counter-pipe) into position and push one half of the clamping ring onto the pipe flange. Make sure that the pipes are aligned squarely and that the seals are not displaced.

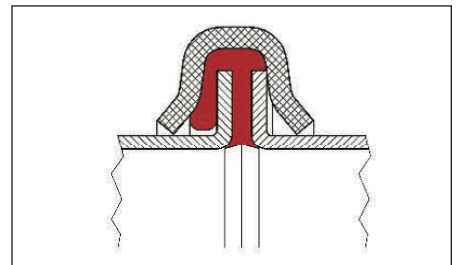

4 Completely separate the two sections of the pull ring to be used.

5 Connect the two sections of the pull ring around the flange, loosely tighten using the bolts using your fingers. Make sure that the pull ring is aligned around the entire flange. Make sure that the u-shaped seal is aligned and not protruding from the pull ring in any location.

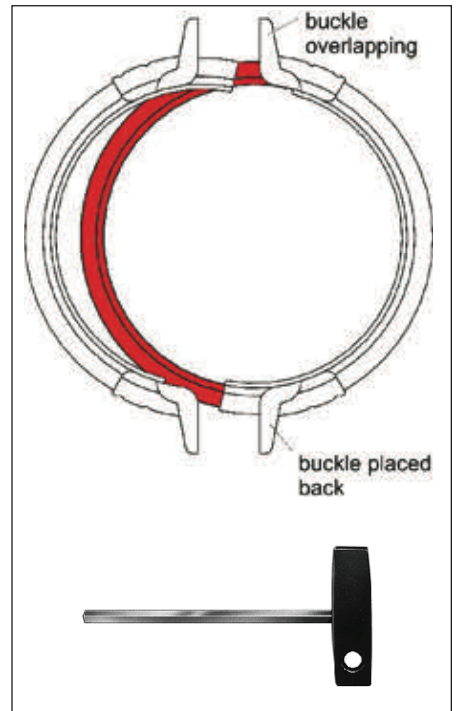

6 Tighten, alternating from one bolt to the other, the bolts to clamp the pull ring around the flange. Use a 6 mm hexagon screwdriver and tighten the bolt to a maximum torque of 25 Nm.

Using Slip Tubes

Slip tubes can be used to achieve specific lengths of pipe without having to cut, weld, or flange additional piping.

NOTE: Slip tube connections must be secured against displacement. For horizontally installed tubing, tubes must be supported in the area of the slip connection to prevent sagging. The weight of the vertical runs should also be supported at the first available horizontal location, to keep joints from displacing in vertical runs.

IMPORTANT: Slip tubes are not meant to be used as telescoping tubes. They are not designed to be adjusted during operation.

To order a slip tube or other parts for your hard pipe kit, Conair's Instant Access 24/7 Parts and Service number is 800-458-1960. Outside the U.S., dial 814-437-6861.

1 Roll the ring seal onto the slip tube.

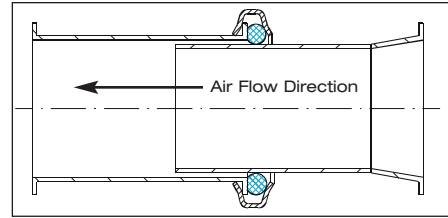

2 Slide the standard tube into the slip tube to the desired length.



NOTE: The slip tube overlap must be at least 1.79 inches {45.5 mm} and at least 1.77 inches {45.0 mm} of the tube must be above the flange for proper operation. If ordering a slip tube to fit into your hard pipe kit, be sure to order a length that accommodates these allowances. For example: do not order an 8 inch slip tube for a 7 inch gap, because the overlap will not be great enough.

3 Roll the ring seal back to the flange and secure with a pull ring.

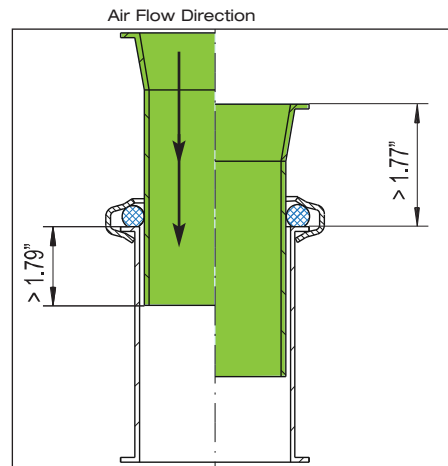

4 Tighten, alternating from one bolt (side) to the other, the bolts to clamp the pull ring around the flange. Use a 6 mm hexagon screwdriver and tighten the bolt to a maximum torque of 25 Nm.

Attaching flange to top of dryer

 **CAUTION: Hot surfaces.** Always protect yourself from hot surfaces inside and outside the dryer and drying hopper.

 **NOTE:** Depending on your dryer model and the hard pipe kit that you ordered, this flange may already have been attached to your dryer.

Your hard pipe kit a Conair flange adapter. This adapter must be attached to the dryer prior to assembling the rest of the hard pipe system.

1 If adding the hard pipe kit to an existing drying system, **remove the flexible hose from the dryer inlet and outlet.** Make sure that the dryer inlet and outlet are clean and ready for installation of the flange adapter(s).

2 Locate the Conair flange adapter and hard pipe gasket.

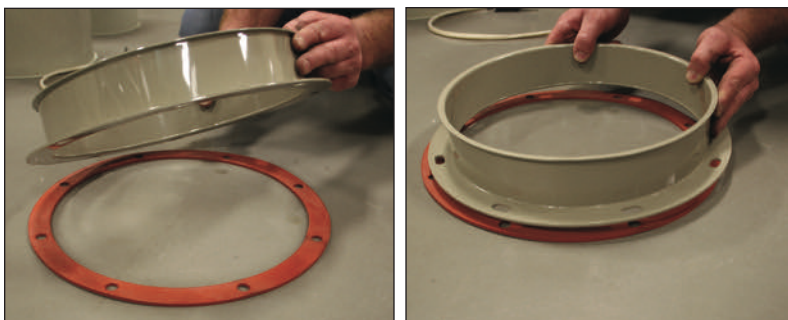

3 Using the included hardware, attach the Conair flange adapter to the dryer outlet.

4 Place the “U” seal on the top of the flange adapter.

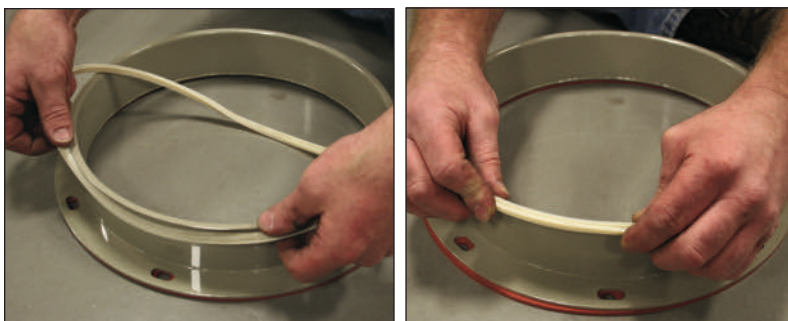

5 Place the next pipe section on the top of the flange adapter.



6 Use the bolted pull ring to connect the pipe section to the flange adapter.

7 Tighten the bolted pull ring bolt to a maximum torque of 25 Nm.



Adding Turns/Bends

To order a slip tube or other parts for your hard pipe kit, Conair's Instant Access 24/7 Parts and Service number is 800-458-1960. Outside the U.S., dial 814-437-6861.

Once you have assembled your verticle section above the dryer, you will need to add the 90° bend to continue horizontally. A slip tube may need to be used as part of the last section before the turn to horizontal to fit your plant/system layout. *Refer to Using Slip Tubes earlier in these instructions* for more information about using slip tubes for more flexibility with your hard pipe kit.

- 1 Verify that when you add your bend or turn, you will be at your desired height for the horizontal run of your hard piping.** It may be necessary to utilize a slip tube to complete your vertical pipe section at the correct height.

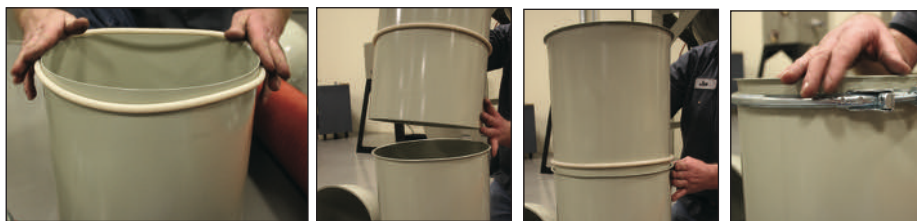

- 2 Place the u-shaped gasket seal on the top of the pipe end.**



- 3 Place the bend on top of the pipe end.**

- 4 Use the bolted ring to connect the bend to the pipe.**

- 5 Tighten the bolted pull ring bolt to a maximum torque of 25 Nm.** Be sure to alternate tightening bolts from one side to another so that the pull ring clamps securely and evenly around the pipe flange.



NOTE: Slip tube connections must be secured against displacement. For horizontally installed tubing, tubes must be supported in the area of the slip connection to prevent sagging.



IMPORTANT: Slip tubes are not meant to be used as telescoping tubes. They are not designed to be adjusted during operation.

Optional VFD Velocity Meter tubing (required for VFD operation)

The velocity meter requires a special section of hard pipe, with a tapped fitting location for the velocity meter installation. The compression fitting allows the velocity sensor to be oriented such that the hole (noted by a mark on the sensor) can be positioned to face the air-flow, and adjusted such that the depth of sensor hole is located in the center of the air flow in the piping.

The section of tubing with the velocity meter tap should be located about 10x the tube diameter (80 inches for 8-inch tubing) of straight pipe (after a bend) on the return line before the dryer. Due to velocity meter cable length and tubing runs, the best location is typically as close to the “Return air” inlet of the dryer on the return air tubing as possible. This typically gives the maximum straight run of tubing prior to the velocity meter location.

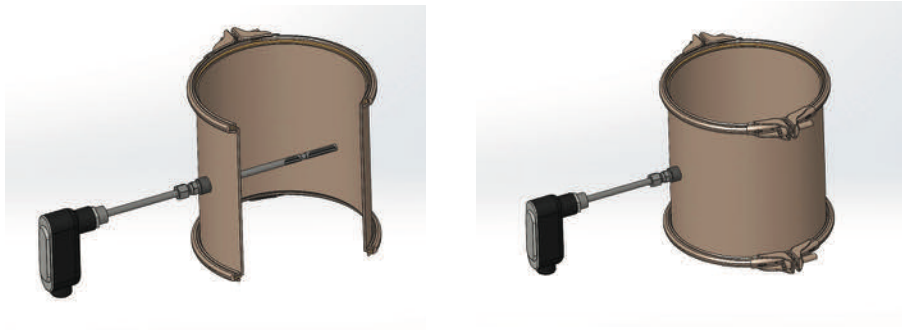

Proper Location and use of Hanger, Clamp, and All-thread

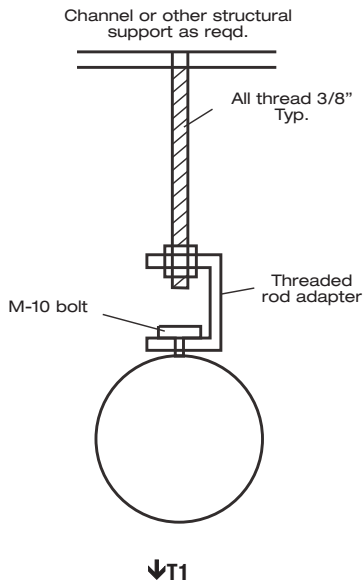

Your Conair Hard Pipe Kit comes with a quantity of tubing hangers (varies depending on which kit you order) for supporting the weight of the horizontal and vertical spans, specifically spans that use slip tube sections. A hanger should be placed on either side of any location where a slip tube was used. This includes supporting a vertical section where a slip tube was used by utilizing a hanger at the closest horizontal location to support the vertical section.

Proper hanging method uses:

- Ceiling mount clamp with rubber insert
- Threaded rod adapter
- M-10 bolt
- Proper length of all-thread - 3/8" tip and proper connection to approved load carrying structure

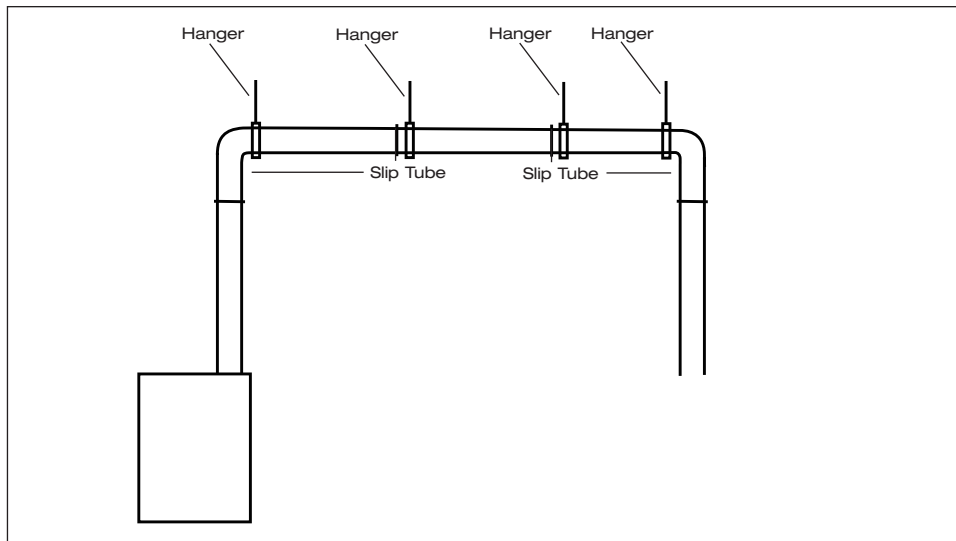

NOTE: T1 ✕ 440 lbs. {195.58 kg} at 0.2 in. {5.08 mm} deflection.

NOTE: Always follow all local and regional building codes when installing.

NOTE: Conair recommends the use of hangers at 10 ft. {3.05 m} intervals at minimum for appropriate support.

