

USER GUIDE
UGH011-0201



www.conairgroup.com

Cooling Towers

E1 Series



Please record your equipment's model and serial number(s) and the date you received it in the spaces provided.

It's a good idea to record the model and serial number(s) of your equipment and the date you received it in the User Guide. Our service department uses this information, along with the manual number, to provide help for the specific equipment you installed.

Please keep this User Guide and all manuals, engineering prints and parts lists together for documentation of your equipment.

Date: _____

Manual Number: UGH011-0201

Serial Number(s): _____

Model Number(s): _____

DISCLAIMER: Conair shall not be liable for errors contained in this User Guide or for incidental, consequential damages in connection with the furnishing, performance or use of this information. Conair makes no warranty of any kind with regard to this information, including, but not limited to the implied warranties of merchantability and fitness for a particular purpose.

INTRODUCTION	2
Table of Contents	3
Specifications	4
ATTENTION: Read this so one gets hurt.....	6
CONAIR COOLING TOWERS	7
Principle of cooling towers	7
Cooling tower terms and definitions.....	7
Water treatment.....	8
GENERAL INFORMATION.....	9
Approximate Weights	9
Dimensions and other physical data	9
HANDLING AND INSTALLATION.....	10
Safety.....	10
On-Site inspection.....	10
Location of the Conair cooling tower	10
Hoisting of the cooling tower	11
Cooling tower installation.....	12
Wiring of Fan Motor and Accessories	12
Piping and tower connections	13
Duct to blower housing installation	14
PVC solvent cementing instructions.....	16
OPERATION AND MAINTENANCE	17
V-belt alignment and tensioning.....	17
Start-up instructions	18
Operating design condition checklist.....	19
Disassembly and cleaning.....	20
Water level	21
Cold weather operation	22
TROUBLE SHOOTING	24
APPENDIX	27
Optional accessories.....	27
Accessories Description	28
Recommended replacement parts	34
Appendices / References	35
Preventative Maintenance Checklist.....	36

E1 SERIES FORCED DRAFT MODELS 10 TO 75 TONS



Model E1-40

EFFICIENT COOLING IN A RUST-FREE DESIGN

Conair's E1 series forced draft, counterflow cooling towers are rust-proof, not just rust-protected. We're so confident the molded polyethylene shell will not rust, chip or crack, we back it with a 15-year warranty.

All water connections, the water distribution system and the wet decking are made of PVC to eliminate corrosion and resist rot, decay and biological attack.

The forward curved centrifugal belt-driven blowers are made of heavy-duty steel with a corrosion-resistant dipped and baked alkyd finish.

LESS WATER AND SEWER USAGE; SAVE MONEY

Conair cooling towers pay for themselves by recirculating process cooling water, which saves water costs and sewer taxes.

Hot water enters at the top and is sprayed over a continuous coil of angled-baffle PVC decking. Air flowing upward from the base removes the heat through evaporation. The spiral decking design extends the water's travel path and exposure to air, increasing the heat transfer area for efficient cooling.

Interchangeable, non-clogging nozzles and laterals permit increased flow without increasing inlet pressure.

Options include: a blower sound enclosure that also serves as a protective housing; two-speed blower motors to closely control temperature and save energy; and basin heaters.

■ Easy inlet/outlet connections

Single-point inlet water connection. Choose the optional side outlet with make-up float valve, or the standard bottom outlet for use with remote tanks and sumps. Also includes drain and overflow connections.

■ Seamless, rust-free design

Our one-piece MDPE tower shell will not rust, corrode, chip, crack or require protective coating or painting. There are no seams, panels or rivets to fail or compromise performance. All fasteners are 304 stainless steel.

■ Costs less to install

Towers are shipped factory complete, requiring little more than water and electrical connections to install. Lightweight design reduces rigging and structural roof support requirements.

■ 15-year warranty

Our cooling towers carry an unbeatable warranty package. We warrant the polyethylene shell against material defects and workmanship for 15 years. We also warrant the TEFC blower motor for five years and provide a one-year parts and labor warranty on the entire tower.

**E1 SERIES FORCED DRAFT MODELS
10 TO 75 TONS**

SPECIFICATIONS

MODELS E1-10 to E1-25

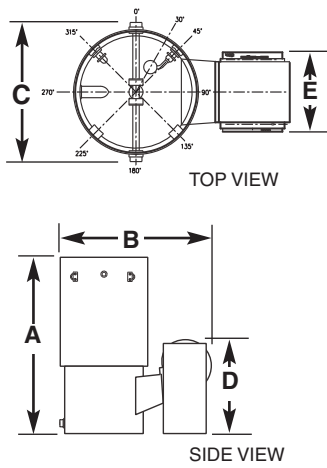

MODELS E1-30 to E1-75

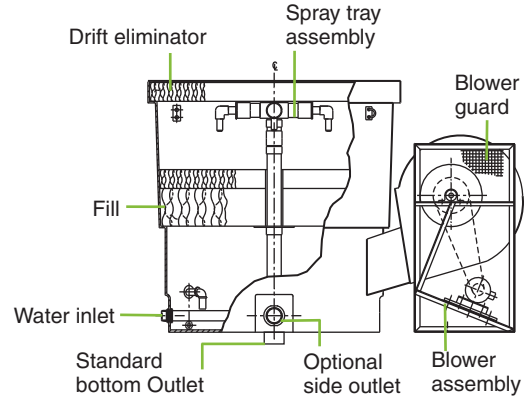
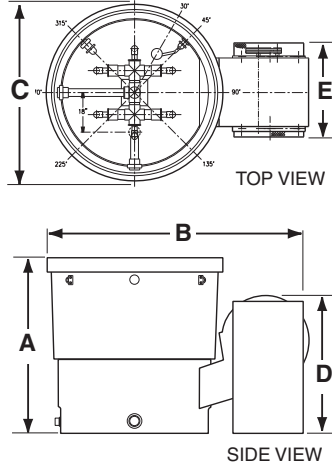

MODEL	E1-10	E1-15	E1-20	E1-25	E1-30	E1-40	E1-50	E1-75
Performance characteristics								
Tower capacity tons	10	15	20	25	30	40	50	75
Sump capacity gallons {liters}	40 {151}	40 {151}	40 {151}	40 {151}	75 {284}	75 {284}	157 {594}	57 {594}
Blower motor Hp {kW}	1 {0.74}	1.5 {1.12}	2 {1.49}	3 {2.24}	5 {3.73}	5 {3.73}	5 {3.73}	7.5 {5.59}
Wet bulb temperature Output tower tons (GPM)*								
70°F {21°C}	14 {44}	22 {67}	29 {89}	37 {111}	44 {134}	59 {179}	74 {223}	111 {335}
72°F {22°C}	13 {41}	20 {62}	27 {83}	34 {104}	41 {125}	55 {166}	69 {208}	104 {312}
75°F {24°C}	12 {36}	18 {54}	24 {72}	29 {90}	35 {107}	47 {143}	59 {179}	89 {269}
78°F {26°C}	10 {30}	15 {45}	20 {60}	25 {75}	30 {90}	40 {120}	50 {150}	75 {225}
80°F {27°C}	8 {25}	12 {37}	16 {50}	21 {63}	25 {76}	33 {100}	42 {126}	63 {189}
Dimensions inches {cm}								
A - Total height		78.5 {199}			76.0 {193}		80.0 {203}	
B - Total width		67.5 {171}			93.0 {236}		114.0 {290}	
C - Total depth		39.0 {99}			56.25 {143}		80.5 {204}	
D - Height, blower assembly		41.75 {106}			60.5 {154}		60.5 {154}	
E - Depth, blower assembly		24.75 {63}			32.0 {81}		38.75 {98}	
Weight lb {kg}								
Shipping (dry)	350 {159}	360 {163}	385 {175}	405 {184}	710 {322}	730 {331}	910 {413}	970 {440}
Operating	705 {320}	725 {329}	750 {340}	765 {347}	1500 {680}	1525 {692}	2610 {1184}	2675 {1213}
Operating with remote sump	425 {192}	445 {202}	470 {213}	485 {220}	970 {440}	995 {451}	1500 {680}	1565 {710}
Voltage Full Load Amps								
208v/3 phase/60 Hz	4.0	5.7	7.5	10.6	16.8	16.8	16.8	24.3
230v/3 phase/60 Hz	3.6	5.2	6.8	9.6	15.2	15.2	15.2	22.0
400v/3 phase/50 Hz	1.9	2.6	3.6	5.0	8.5	8.5	8.5	11.3
460v/3 phase/60 Hz	1.8	2.6	3.4	4.8	7.6	7.6	7.6	11.0
575v/3 phase/60 Hz	1.2	1.8	2.4	3.2	5.0	5.0	5.0	8.0
Connections NPT inches								
Water inlet and outlet†	2.0		2.0/3.0		3.0	3.0/4.0	4.0	
Make-up water	0.75		0.75		1.0	1.0	1.0	1.0
Overflow and drain	1.0		1.0		2.0	2.0	2.0	2.0
Water requirements ‡								
Inlet pressure psi {bars}		5 - 7 {0.24 - 0.48}			5 - 7 {0.24 - 0.48}		5 - 7 {0.24 - 0.48}	
Maximum inlet temperature		150°F {66°C}			150°F {66°C}		150°F {66°C}	

SPECIFICATION NOTES

* Based on 95°F {35°C} inlet water and 85°F {29°C} outlet water. Consult factory for other conditions. 1 tower ton = 15,000 Btu/hr.
 † Side outlet, shown, is optional. The standard bottom outlet is installed at the center of the tower bottom.
 ‡ Due to the unique interchangeable nozzle design of the E1 Series Cooling Towers, customer specifications must include design flow requirements.
 Specifications may change without notice. Contact your Conair representative for the latest information.

Attention: Read this so no one gets hurt.

Questions regarding the installation, operation or maintenance of this equipment should be directed to Conair (1-800-458-1960) .

Step-by-step instructions contained in this brochure are based on normal installation conditions only. Abnormal or unusual combinations of field conditions should be brought to the attention of Conair or its representative prior to installation of the equipment. The information contained herein is subject to change without notice in the interest of product improvement.

We design equipment with the user's safety in mind. You can avoid the potential hazards identified on this machine by following the procedures outlined below and elsewhere in the User Guide.

WARNING: Improper installation, operation or servicing may result in equipment damage or personal injury.

This equipment should be installed, adjusted, and serviced by qualified technical personnel who are familiar with the construction, operation and potential hazards of this type of machine.

All wiring, disconnects and fuses should be installed by qualified electrical technicians in accordance with electrical codes in your region. Always maintain a safe ground. Do not operate the equipment at power levels other than what is specified on the machine serial tag and data plate.

WARNING: Precautions need to be taken to minimize contact with health hazards.

Health hazards, such as chemicals or biological contaminants may be present in the cooling water. These contaminants can include Legionella bacteria which can cause serious sickness or death. Appropriate personal respiratory and skin protection should be worn by personnel who are exposed to the discharge air stream, mists generated by the operation of the tower equipment or are exposed to the water or air streams that are used to clean the tower and its components. Consult MSDS sheets concerning exposure to the chemicals added to the water system.

Conair Cooling Towers

PRINCIPLE OF COOLING TOWERS

All cooling towers operate on the principle of removing heat from water by evaporating a small portion of the water that is recirculated through the unit.

The heat that is removed is called the latent heat of vaporization.

Each one pound of water that is evaporated removes approximately 1,000 BTU's in the form of latent heat.

COOLING TOWER TERMS AND DEFINITIONS

BTU - A BTU is the heat energy required to raise the temperature of one pound of water one degree Fahrenheit in the range from 32° F. to 212° F.

Cooling Range - The difference in temperature between the hot water entering the tower and the cold water leaving the tower is the cooling range.

Approach - The difference between the temperature of the cold water leaving the tower and the wet-bulb temperature of the air is known as the approach. Establishment of the approach fixes the operating temperature of the tower and is a most important parameter in determining both tower size and cost.

Heat Load - The amount of heat to be removed from the circulating water within the tower. Heat load is equal to water circulation rate (gpm) times the cooling range times 500 and is expressed in BTU/hr. Heat load is also an important parameter in determining tower size and cost.

Ton - An evaporative cooling ton is 15,000 BTU's per hour.

Wet-Bulb Temperature - The lowest temperature that water theoretically can reach by evaporation. Wet-Bulb Temperature is an extremely important parameter in tower selection and design and should be measured by a psychrometer.

Pumping Head - The pressure required to pump the water from the tower basin, through the entire system and return to the top of the tower.

Drift - The water entrained in the airflow and discharged to the atmosphere. Drift loss does not include water lost by evaporation. Proper tower design and operation can minimize drift loss.

Total Dissolved Solids – The amount of minerals in solution with the water, which can not be removed by filtration. Usually measured in parts per million (PPM) and includes chlorides, sulfates, or carbonates which can cause corrosion or scaling in the system.

Cycles of Concentration – Ratio of the dissolved solids in recirculating water to the dissolved solids in make-up water.

Bleed Off (Blowdown) - The circulating water in the tower which is discharged to waste to help keep the dissolved solids from concentrating in the water below a maximum allowable limit. As a result of evaporation, dissolved solids concentration will continually increase unless reduced by bleed off.

Make-Up - The amount of water required to replace normal losses caused by bleed-off, drift, and evaporation.

WATER TREATMENT

- * The Conair Cooling Tower shell is fabricated of corrosion-resistant plastics which are resistant to water treatment chemicals including common fungicides and bactericides.
- * Follow appropriate water treatment practices as required and take frequent sample tests to avoid possible water contamination. We also recommend water treatment maintenance as a measure of protection for the environment in the vicinity of any cooling tower or other equipment open to atmosphere.
- * To determine the appropriate water treatment practices for your particular application, it is suggested that you contact a water treatment firm for their recommendation. A list of water treatment firms is available for your reference. It is not necessarily complete nor do we recommend a specific firm. The list will be mailed to you on request or consult your local yellow pages.
- * Bleed-off is also important to water quality. Evaporation of the recirculated water does not remove the dissolved solids that are present in the water. Without bleed-off, the continual buildup of these solids will impair the proper functioning of the piping and other equipment in the system.
- * A bleed line can be connected in any part of the system with routing to the sewer. Normally, it is most desirable to make this connection in the hot water line at the cooling tower. A petcock type valve, installed in the bleed line is recommended. Normally, bleed-off of 1% to 2% of the recirculation water flow is satisfactory. The required amount of bleed-off water must be substituted with properly controlled amounts of make-up water.
- * If biocides or corrosion inhibitors are used, then consult local authorities before introducing bleed-off water to a sanitary sewer.

General Information

APPROXIMATE WEIGHTS

The induced draft cooling towers are manufactured in two basic sections; a polyethylene tower body and a fan assembly section. Both of these sections are factory assembled and shipped as complete units, eliminating field assembly of each unit.

Model #	Shipping	Operating	Overall Dimensions
E1-10	350	705	67.5" x 39" x 78.5"
E1-15	360	725	67.5" x 39" x 78.5"
E1-20	385	750	67.5" x 39" x 78.5"
E1-25	405	765	67.5" x 39" x 78.5"
E1-30	710	1500	93" x 56.25" x 76"
E1-40	730	1525	93" x 56.25" x 76"
E1-50	910	2610	114" x 80.5" x 80"
E1-75	970	2675	114" x 80.5" x 80"

DIMENSIONS AND OTHER PHYSICAL DATA

For cooling tower dimensions, design for foundations, assembly and layout, refer to the following drawings which are a part of these instructions:

Model #	Title	Drawing No.
E1/10 – 25	Assembly	DT-C-78-100
E1/ 30 – 40	Assembly	DT-C-78-200
E1/ 50 – 75	Assembly	DT-C-78-300

Handling and Installation of Your Cooling Tower

SAFETY

When handling, lifting, installing or operating the cooling tower, always employ safe working procedures, according to the best practices of the trade and according to applicable construction, electrical and safety standards, regulations and codes.

Follow all safety practices described in these instructions.

ON-SITE INSPECTION

Upon arrival at the job site, carefully inspect the shipment for any damage. If shipping damage has occurred, notify the driver or the carrier immediately in writing of all damage. Check that all items listed on the Shipping Bill of Lading have been received.

LOCATION OF THE CONAIR COOLING TOWER

Proper location of the cooling tower is essential to its satisfactory operation. The following are recommendations for the selection of a cooling tower site. Consult the factory or our representatives for additional assistance in selecting equipment and equipment locations.

- * Select an open site having an unobstructed air supply and free air motion.
- ☛ If the site is adjacent to a wall or other structure that blocks prevailing winds, install the cooling tower so that top discharge is slightly higher than the structure. Locate the blower at farthest point from the structure, facing the direction of the prevailing winds.
- ☛ Gravity drain to indoor storage sump requires proper head differential and pipe design considerations. Allowance must be given based on flow, pipe size, piping layout and the distance the cooling tower is located from the indoor storage pump.
- ☛ Should it be necessary to locate cooling tower near walls or within enclosures, choose a location that will not restrict air flow. Do not install cooling tower in a well or below the level of an obstruction that might impede air

discharge, cause short circuit of air flow, or result in recirculation of the discharge air back into the blowers.

- Do not locate cooling tower near heat-generating equipment, which could interfere with temperature of inlet air or ambient wet-bulb temperature to the cooling tower.
- Do not install a canopy or roof of any kind over the cooling tower which would deflect discharge air back down around the cooling tower and cause recirculation of the discharge air back into the blowers.

HOISTING THE COOLING TOWER

For roof mounted installations, it is recommended that a hoist using two or more safety slings and spreader bars, as shown in the illustration, be used to lift the cooling tower onto the building.

Secure the safety slings completely around and under the cooling tower. Provide padding to protect the edges of the polyethylene shell at points of sling contact. The slings should be secured in a girdle fashion for a double secure point of lift. Slings should be brought up snug around the tower before lifting onto the building.

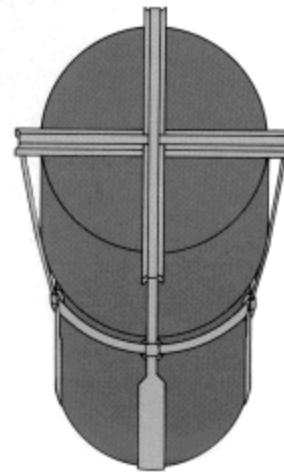

Recommended Hoist for Cooling Tower

Blower Assembly

The blower assembly should be hoisted onto the building, prior to the removal of the shipping skid, in the same manner as the cooling tower. Any questions regarding to the hoisting for roof mounted installations should be directed to Conair.

NOTE: DO NOT USE BLOWER SUPPORT FRAME FOR HOISTING.

COOLING TOWER INSTALLATION

Conair cooling towers have been designed to provide maximum performance, long life and trouble-free service. To assure optimum performance, the following recommendations should be followed as closely as possible.

Positioning the tower:

The tower should be installed on a continuous firm, smooth, and level concrete, steel, or wood foundation.

Spacing for piping and service access should be considered when positioning the cooling tower. Also, to insure an adequate positive suction head, the pump should be located below the bottom of the cooling tower sump.

Outdoor Installation:

The cooling tower may be placed in virtually any outdoor location. However, the following points should be taken into consideration.

- The tower should be placed so that the air supply to the fans is not restricted.
- The discharge air should not be deflected downward into the fan air intake.

WIRING OF FAN MOTOR AND ACCESSORIES

- * Installation of a vibration cutout switch is recommended. (Refer to tower accessories available)
- * All electrical work should be performed only by qualified personnel and in accordance to prevailing electrical codes, practices and safety standards.
- * The motor starter should be sized on voltage, nominal horsepower, and maximum full load current. This current value can be found on the nameplate. If the starter cannot accept the maximum full load motor current, the next size should be used.
- * Motor heaters should be selected on the basics of maximum full load current and service factors based on the motor nameplate.
- * Standard "Cooling Tower Service" motors are supplied with a minimum of a 1.15 Service Factor.
- * Optional two speed motors are single winding variable torque.
- * Run flexible conduit with some slack from the motor conduit box to terminal box outside the tower where rigid conduit can be used.
- * Conduit holding clip screws can be tapped directly into the tower wall. Use maximum 3/8" screws.
- * For the typical wiring schematic of fan motor and tower accessories, see the electrical schematic included with these instructions.

PIPING AND TOWER CONNECTIONS

☛ Piping should be adequately sized according to accepted standard practices. Refer to the factory drawings for size and types of connections furnished as standard.

* An indoor storage sump is the preferred method for a system installation. The indoor sump tank should be large enough to fill the entire recirculation system without danger of pump cavitation. As a general rule, the tank should be sized to hold three times the rate of circulation in gallons per minute (gpm). The tank should be provided with properly sized overflow, make-up, drain and suction connections. When a separate sump is ordered with a cooling tower, the water make-up valve assembly and the overflow and drain connections are installed in the indoor sump only. The cooling tower should be located high enough above it to allow free cold water gravity drain. A bottom outlet is provided for gravity drain to indoor sump tank installations. A provision must be made to make sure that the outdoor piping to the tower does not freeze. Insulation and heat tracing can help prevent freezing. Providing a bleed line on the outdoor piping, which will allow the piping to drain back to the sump when the pump is not running, can also do this. It is only necessary to drain the exposed piping.

* Reverse siphoning is a back flow of non-potable, recirculating water into a potable water system, which can occur through the make-up float valve assembly located in the water reservoir. Should the valve malfunction, blockage of the overflow or outlet lines will cause the water level to rise in the reservoir, and the make-up water pressure could drop below the atmospheric pressure creating a vacuum at the make-up inlet. Although precautions to prevent reverse siphoning are incorporated in the cooling tower design, we also recommend installing a backflow preventer valve in the water make-up supply line as a backup precaution. Consult local water authority for type of backflow preventer required.

* Gravity drain to indoor storage sump requires proper head differential and piping design considerations. Allowance must be made for flow, pipe size, piping layout and distance of cooling tower from the indoor storage sump.

☛ On multiple tower installations, pipe sizing should balance pressure drops to provide equal inlet pressures. Equalizing lines can be connected between cooling tower sumps and are available as an option from the factory. Each unit should be valved separately to allow for flow balance or isolation from service.

☛ All supply and return piping must be independently supported. See page 17 for instructions for the preparation, and cementing of internal and external piping.

☛ An inlet pressure gauge should be installed immediately before the cooling tower inlet connection. See Operating Design Condition Checklist.

☛ The makeup connection is provided with a float valve and ball assembly for proper water level control on the side outlet tower.

☛ The overflow connection includes an elbow and extension pipe that drops below the water level in the tower sump.

NOTE: NEVER BLOCK OVERFLOW CONNECTION. WATER SHOULD BE ALLOWED TO FLOW FREELY WITHOUT OBSTRUCTION.

- ☛ The outlet connections for pump suction applications are provided with a vortex breaker.

NOTE: FOR GRAVITY FLOW APPLICATIONS: A VORTEX BREAKER IS NOT REQUIRED OR PROVIDED. A VENT PIPE OR BLEED VALVE SHOULD BE INSTALLED AT THE HIGHEST ELBOW OF THE PIPING SYSTEM, TO PREVENT AIR LOCKS AND INSURE FREE FLOW OF WATER. AIR LOCKS CAN CAUSE GRAVITY FLOW RESTRICTION RESULTING IN EXCESSIVE WATER ACCUMULATION AND EVENTUAL OVERFLOW OF THE COOLING TOWER.

- ☛ The outlet, makeup, and overflow connections are notched at the outer ridge and should be held in position with the notch at 12 o'clock. This is to insure proper position of the vortex breaker, float valve assembly and overflow extension, which are internal and not visible from the exterior of the cooling tower.

- ☛ The inlet fitting of models E-10 through E-40 is notched in the same manner as described above to insure proper spray nozzle position.

- ☛ PVC bulkhead connections must be held steady and in their factory-installed positions when the connecting piping is being installed.

- ☛ When threading pipe to the bulkhead fittings do not allow fittings to turn.

Turning can loosen the locknut or squeeze the gasket out of position and may cause leaks. PVC bulkhead fittings should be tightened with a chain wrench so that the gaskets all sit properly between the cooling tower shell and the fitting. Do not overtighten. A bulkhead fitting that is too tight or too loose can cause the gasket to crimp or squeeze away from the locknut, causing leaks around these connections.

DUCT TO BLOWER HOUSING INSTALLATION

Blower Hood – The blower hood completely encloses the blower to offer maximum protection to personnel who might accidentally contact the rotating components.

The blower hood provides protection against rain and windblown debris entering the standard double inlet blower assemblies. It also protects the motors and drives from the water spray which may affect operation.

The hood offers an aesthetic quality to the blower assembly because it is molded from the same medium density polyethylene material as the tower shell and its appearance is consistent with the tower shell.

The hood also serves as an additional sound dampening device for the already very quiet standard Conair blower assemblies. With these hoods properly installed, a 3 d BA reduction at 5 feet is common.

The hood inlets are covered with a PVC coated 3/8" #2 wire mesh screen fastened to the hood with stainless steel hardware.

☛ To install duct to blower housing place lip of duct over lip of blower housing as shown. With seven screws supplied, fasten duct to housing using two screws on each side and three on the bottom.

On models E-10 through E-25 install duct sizes outside blower housing. On all other models, install duct sizes inside blower housing. Install bottom of duct to outside of blower housing on all models.

☛ Seal off air leaks around duct with duct tape.

NOTE: THE BLOWER SUPPORT FRAME MUST BE BOLTED TO THE FOUNDATION. THE ASSEMBLY IS FURNISHED WITH PRE-DRILLED BOLT HOLES. SHIMMING MAY BE REQUIRED FOR PERFECT FIT.

☛ Damage to painted surface of blower housing during installation must be repaired immediately to prevent corrosion.

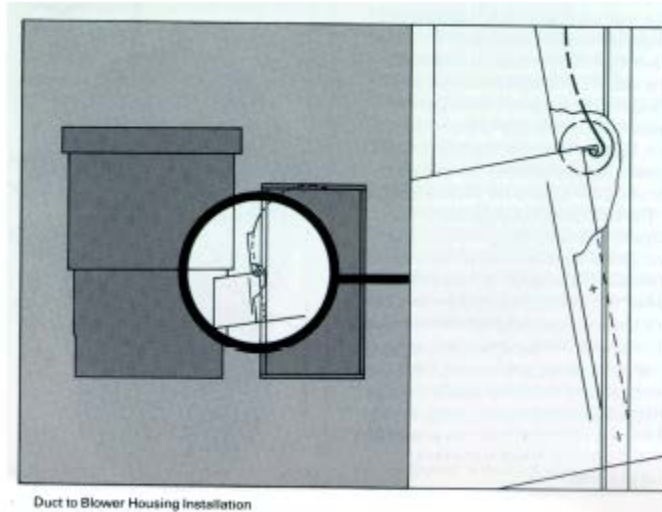

PVC SOLVENT CEMENTING INSTRUCTIONS

The following procedure is recommended for the preparation and cementing of internal and external piping for Conair Cooling Towers:

- * Cut ends of pipe square using a handsaw and miter box. Tube cutters with wheels designed for use with PVC are acceptable, providing they do not leave a raised bead on the outside diameter of the pipe.
- * Use a chamfering tool or file to put a 10° to 15° chamfer on the end of the pipe. Lightly sand the area to be cemented to remove gloss. Using a clean rag, wipe pipe surface and fitting socket to remove dirt, moisture and grease. Acetone or similar solvent is recommended for cleaning.
- * Check "dry fit" of pipe and fitting by inserting pipe at least 1/3 of the way into the fitting. Position pipe and fitting to assure alignment. Pipe and fitting should be at the same temperature condition.
- * Using a clean, natural bristle brush about 1/2 the size of the pipe diameter, apply a primer to the fitting socket. Apply primer with a scrubbing motion until the surface is penetrated. Primer should never be applied with a rag. Repeated applications may be necessary to achieve the desired dissolving action. In the same manner, apply primer to the pipe surface equal to the depth of the fitting socket, making sure the surface is well penetrated. Reapply primer to the fitting socket to make sure it is still wet.
- * While both surfaces are still wet with primer, use a clean brush to apply a liberal coat of solvent cement to the male end of the pipe. The amount should be more than sufficient to fill any gap. Next apply a light coat of solvent cement to the inside of the socket, using straight outward strokes to keep excess cement out of the socket.
- * While both surfaces are still wet with solvent cement, insert the pipe into the socket with a quarter-turn twisting motion. The pipe must be inserted the full length of the socket. The application of solvent cement to pipe and fitting, and the insertion of the pipe into the fitting, should be completed in less than one minute. If necessary, two persons should apply solvent cement to the pipe and fitting simultaneously.
- * Hold the joint together for approximately 30 seconds until both surfaces are firmly gripped. After assembly, a properly made joint will usually show a bead of cement around its entire perimeter. This bead should be brushed off. It is recommended that the joint be allowed to cure for 24 hours before pressure testing or operation.

Operation and Maintenance

Safety

Follow all safety instructions previously discussed.

V-BELT ALIGNMENT AND TENSIONING

Proper belt tension is the most important factor in the successful operation of a V-belt drive. The belt tension should be checked frequently during the first 24 hours of operation and then periodically on a maintenance schedule. Loose belts cause slippage, which reduces air flow and can adversely affect belt life and cooling tower performance.

The following belt tensioning procedure are recommended:

- Check that the driver and driven sheaves are in alignment by placing a straight edge across the sheaves at four contact points as shown. If realignment is required, loosen the motor sheave bushing screws and align the sheaves.
- To tension the belts adjust the motor base so that the belt will deflect about 1/2" when moderate pressure is applied to the belt midway between the sheaves as shown in the illustration.

NOTE: EXCESSIVE BELT TENSION CAN SHORTEN BELT AND BEARING LIFE. LOOSE BELTS OR MISALIGNED SHEAVES CAN CAUSE UNSEATING AND BREAKAGE OF BELTS. REPLACEMENT OF MULTIPLE BELT SYSTEMS SHOULD BE MADE IN MATCHED SETS.

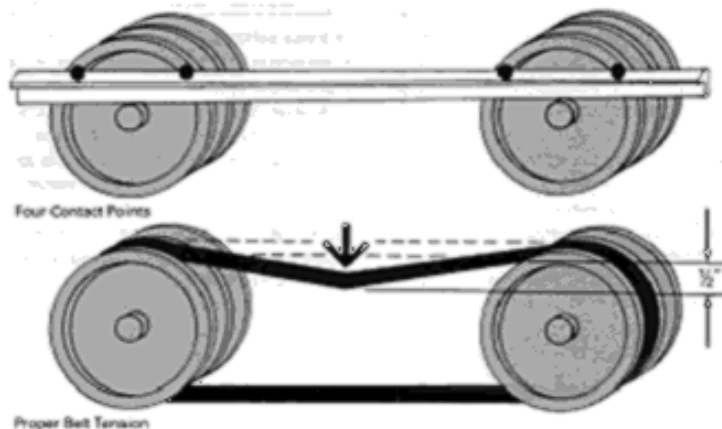

START-UP INSTRUCTIONS

Complete all start-up instructions before applying heat load.

- * Clean any accumulated debris or packaging material from inside tower sump.
- * Check to be sure that the fan motor is properly wired for correct rotation as viewed from the top of the fan. Reverse leads will cause incorrect rotation and reverse direction of airflow.

Note: Fan rotation should always agree with rotation labels. Standard fan rotation is clockwise, (C.W.) however non-standard fans may be designed to rotate counter clockwise, (C.C.W.)

- * Check for free rotation of the fan and fan blade tip clearance.
- * Fill the cooling tower sump or the cold water storage reservoir on gravity drain applications.
- * Water recirculation pump should be primed and all piping below the tower sump filled with water. Check pump for proper shaft rotation.
- * Start water recirculation pump and adjust flow to design. A flow metering device installed in the inlet is recommended, but if not available, use the pressure differential across the pump in conjunction with the pump curve.
- * Check flow pattern from sprinkler lateral arms to be sure there is no clogging of orifices. If necessary, clean out lateral arms by removing the nozzles.
- * Start up fan motor and check amperage and voltage against motor nameplate data.
- * The standard make-up valve assembly is shipped with the plastic float ball strapped against the tower side to prevent damage. To set the ball for proper operation, loosen the screw in the fulcrum arm, lift or depress the arm with the plunger pressed against the valve seat and tighten. Repeat until the proper operating level is obtained. It is recommended that a shut-off valve be installed in the make-up line.

After 24 hours of operation:

- ☛ Check lateral arms for clogging.
- ☛ Check tower sump water level.
- * Check belt tension and adjust if necessary

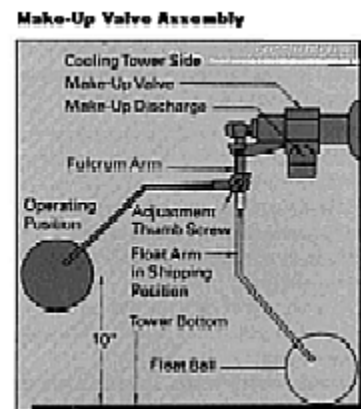

OPERATING DESIGN CONDITION CHECKLIST

For proper operation and maximum efficiency of the cooling tower, the following operating design conditions are essential:

- ☛ The flow rate of the cooling tower must be as close to the design gpm as possible.

The distribution system, including spray nozzles, is provided for the design flow condition. Under pumping or over pumping will cause the cooling tower to perform inefficiently.

- ☛ Design pressure at the inlet connection must be maintained for proper water distribution.

If the pressure is less or greater than the design, proper water dispersion over the internal wet decking will be impaired. If the inlet pressure is low, water spray will not cover the entire wet decking surface. This causes channeling of air and does not make maximum use of the heat transfer media. High inlet pressures will cause the water to over-spray the wet decking media, hit the internal side walls of the tower shell, and drop in a vertical flow along the shell walls without the opportunity for maximum water/air contact through the heat exchange media. Excessive high spray pressure may also cause wet decking fatigue and damage.

The nozzles furnished with standard cooling towers are sized for 3 gpm/ton, requiring 10 psi inlet pressure for models E-50 through E-75, and 7 psi inlet pressure for models E-10 through E-40. This standard will vary when the design flow is less or greater than 3 gpm/ton. Alternate orifice nozzles will be provided in order to maintain the proper inlet pressure requirement.

Correct flow rates and inlet pressures should be determined prior to completion of system installation.

- ☛ Blower motors must be properly wired for counter-clockwise (ccw) rotation of the blower wheel as viewed from the sheave side of the blower assembly.

Reversed leads will cause incorrect rotation and inhibit required air distribution.

NOTE: THE BLOWER MUST ALWAYS OPERATE WITH WATER CIRCULATING THROUGH THE COOLING TOWER TO PREVENT MOTOR OVERLOAD.

- ☛ The maximum operating inlet water temperature should not exceed 150° F.

DISASSEMBLY AND CLEANING (SEE ILLUSTRATION ON

NEXT PAGE)

For models E-10 through E-40

- ☛ Remove drift eliminator from cooling tower. It is flexible enough to push the outer perimeter toward the center and lift over the top lip of the cooling tower shell. Begin at one point and work carefully around the entire circumference of the drift eliminator.

Models E-30 and E-40 are designed without a top lip so the drift eliminator can be easily lifted up and away from the shell.

- ☛ Remove water distribution spray system from inside the cooling tower. The spray system is installed across the top of the tower directly under the drift eliminator. Disconnect locknuts at each end of system and remove piping by elongating top of tower shell slightly.

- ☛ Remove wet decking from cooling tower shell using the plastic hand straps attached for lifting. The wet decking has a smaller diameter than the drift eliminator and will lift easily out of the shell once the distribution spray system is removed.

- ☛ When the internal components are removed, the empty shell can be cleaned and inspected. It is recommended that the water distribution laterals and nozzles be cleaned and flushed before reassembly.

- ☛ To reassemble components, reverse the above procedure. Before installing drift eliminator, pump water through the distribution system to be sure of a good spray pattern and proper water distribution over the wet decking surface.

For models E-50 thorough E-75

Same procedure as above except.

- ☛ These models are designed so the drift eliminator can be easily lifted up and away from the cooling tower shell.

- ☛ The spray tree sections of the water distribution system are threaded to a coupling and unscrew easily. Hold and turn the entire riser below the lateral and nozzles, then carefully remove the whole assembly.

- ☛ The wet decking can now be easily removed using the plastic hand straps attached for lifting.

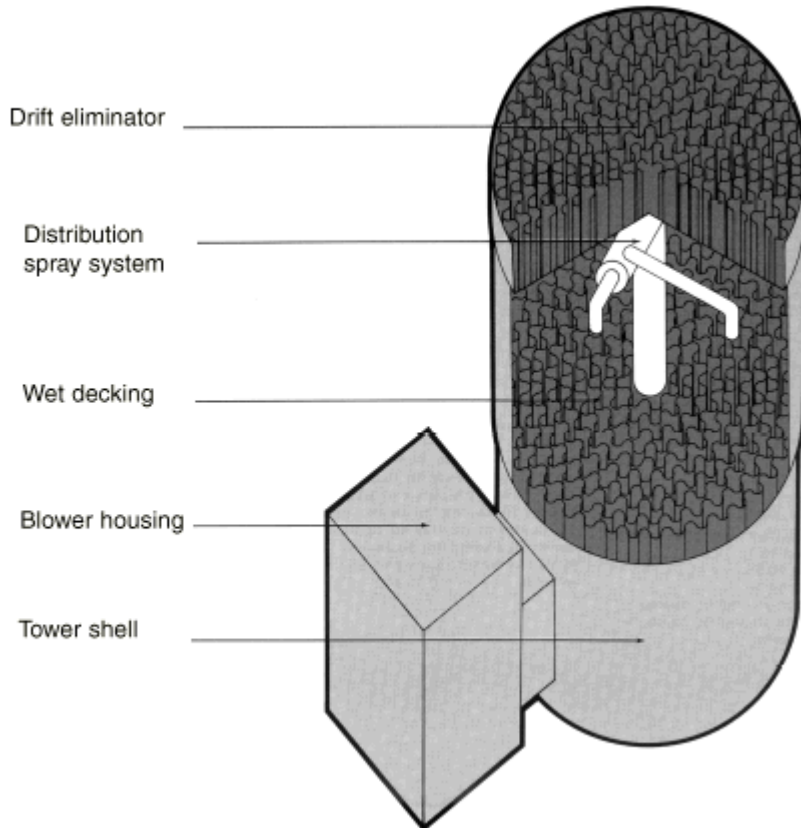

Water Level in Tower Sump

* When the cooling tower is being operated with pump-suction, the make-up valve assembly with float ball should be adjusted to set the water operating level as follows:

Model	Operating Level
E1-10 thru E1-75	10 inches

Access through the inspection port next to the valve.

- * A lower water level than recommended may cause air to be drawn into the tower outlet piping and cause pump air binding or cavitation.
- * A water level higher than recommended will cause continuous overflow and waste of water as a result of potential siphoning from the piping when the system is shut down.
- * The overflow should NEVER be capped, or its elevation altered by raising external piping.

Note: On gravity drain cooling tower(s), make-up valve assembly, overflow, drain and vortex breaker are not provided.

COLD WEATHER OPERATION

Cold Weather Protection:

The cooling tower may require protection against freezing at light heat loads when the wet-bulb temperature is less than 32° F. Or during shutdown when the temperature drops below 32° F.

The following methods are recommended for use with Conair cooling towers for protection during cold weather conditions. Recommended equipment is optional and may be ordered from the factory. Consult the factory for further information on which equipment to choose for you specific application.

Separate Indoor Sump

This method is virtually a foolproof antifreeze protection system with the added advantage of minimum maintenance. The gravity drain to the sump insures that the basin will drain when the pump is turned off.

Electronic Immersion Heater:

Cooling towers ordered with anti-freeze systems are shipped with a protective seat secured under the immersion heater probe which is to remain in place during operation to protect the polyethylene shell from the heater element. NOTE: THIS SEAT IS NOT A SHIPPING BRACE AND MUST NOT BE REMOVED.

Thermostatic On-Off Control:

A thermostatically controlled blower for on-off generation should be considered as an energy-saving capacity control during winter operation. The thermostatic control can be field set to insure automatic blower shut-down when cold water drops below design temperature, as well as blower start-up when cold water rises to design temperature.

A thermostatic control provides excellent cooling tower anti-freeze protection while reducing operating costs through-out cold weather operation.

PVC Distribution system:

To prevent damage to the PVC distribution system during cold weather shut-down, install an automatic or manual drain line from the hot water inlet piping as close to the cooling tower inlet as possible. Locate this drain line to allow the water to drain either to waste or to an indoor storage tank. This precaution will prevent water from being trapped and possibly freezing inside the distribution system.

Suggested cooling tower installation for dry basin operation with indoor storage sump tank.

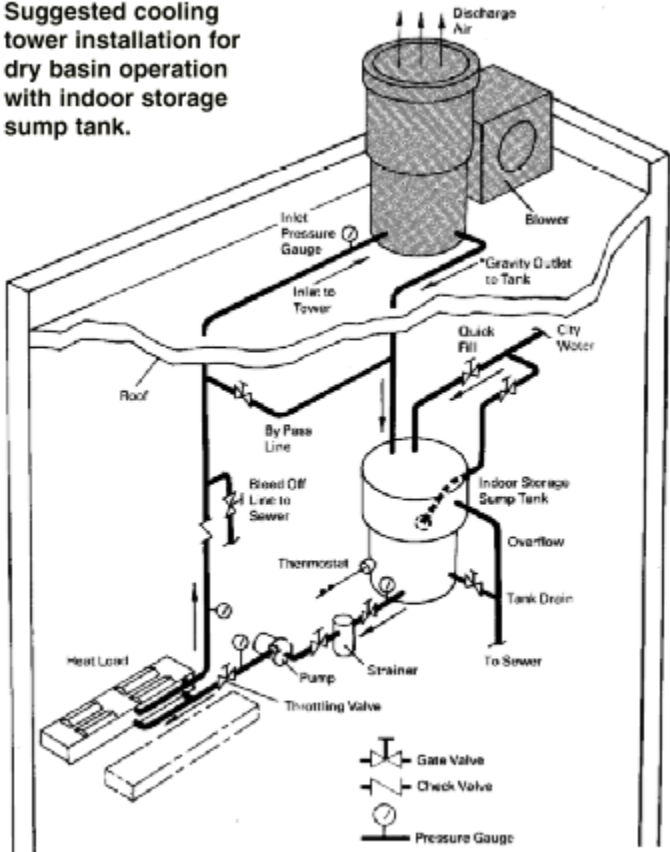

*An outlet in the bottom of the cooling tower can be provided in place of the standard side outlet for gravity return installations.

Piping:

When the cooling tower is located outdoors adequate measures including the use of heating tapes and insulation should be considered to protect water lines from freezing.

Trouble-Shooting Guide For E1 Series Forced Draft Cooling Towers

Problem	Possible Causes	Corrective Actions
Increase in the leaving water temperature	<ol style="list-style-type: none"> 1. Excess water flow; over pumping. 2. Recirculation of hot discharge air, back into the cooling tower air intakes. 3. Obstructed air intakes 4. Proximity of other heat source or discharge of moist air. 5. Improper operation of sprinkler system. <ol style="list-style-type: none"> A. Orifices clogged. 6. Clogged fill. 7. Damaged fill. 8. Additional heat load on system. 9. Wet-bulb temperature higher than design. 	<ol style="list-style-type: none"> 1. Adjust to the design flow. 2. Eliminate obstructions which impede air discharge. For proper location of cooling tower(s), see Conair dwgs. Baffle air discharge, if necessary. 3. Remove source or relocate tower. 4. See water distribution system instructions. <ol style="list-style-type: none"> A. Flush lateral arms, clean orifices, clean system, install outlet strainer. 5. Clean the fill. 6. Replace the fill. 7. Contact Conair for possible upgrade or addition of another cooling tower selected for additional load. 8. None required if condition is temporary. Otherwise consult Factory for upgrade.
Drop in the water flow rate. Low water flow rate	<ol style="list-style-type: none"> 1. Blockage of sprinkler nozzle. 2. Low water level in sump causing air to be drawn into pump and piping. 3. Improper selections of water circulating pump. 4. Blockage of strainers. 5. Pump malfunction. 	<ol style="list-style-type: none"> 1. Flush lateral arms. Clean whole system. Install outlet strainer. 2. Adjust float valves. Be sure the system is flooded and balanced. 3. Replace with proper size pump designed for flow and head requirements. Check pump "Net positive suction head." 4. Backwash or clean. 5. Consult pump specialist.
Noise and vibration	<ol style="list-style-type: none"> 1. Loose bolts. 2. Mechanical interference of rotating parts. 3. Fan blower damaged or out of balance. 4. Air intake at pump. 5. Pump cavitation. 6. Damaged motor bearings. 	<ol style="list-style-type: none"> 1. Recheck and tighten all bolts to specified torque. 2. Inspect propeller for free rotation. Check propeller for mechanical interference. Adjust, repair or replace, as necessary. 3. Replace components, as necessary and check balance. Install vibration cut-out switch. 4. Check basin water level and irregular piping design. 5. Match pump NPSH with system hydraulics. 6. Check and replace motor.
Sudden or short term irregularities of cold water level in basin	<ol style="list-style-type: none"> 1. Peculiarities of specific system and its operation. 	<ol style="list-style-type: none"> 1. Inspect system and review operation procedures. Correct, as applicable valve settings, loss of water in system, fill system to flooded capacity.
Excessively high water level in sump on gravity drain installation	<ol style="list-style-type: none"> 1. Gravity flow restrictions due to insufficient head differential. 2. Airlock. 3. Unnecessary obstruction of waterflow (i.e., partially closed valve). 4. Undersized piping. 5. Horizontal pipe run too long. 6. Improper hydraulic pipe design. 7. Outlet vortex breaker provided. 	<ol style="list-style-type: none"> 1. <ol style="list-style-type: none"> A. Outlet piping should terminate below sump tank water level. B. Increase discharge pipe size. C. Increase head by mean other than A. 2. Install an air bleed valve at highest point of piping, usually at a vertical angle. 3. Remove obstruction. 4. Increase pipe size. 5. Shorten, if possible. 6. Correct design. 7. Remove vortex breaker.

Problem	Possible Causes	Corrective Actions
Excessively high water level in tower basin on closed loop system installations	<ol style="list-style-type: none"> 1. Make-up valve float set too high. 2. Valve or float damaged or malfunctioning. 3. Make-up water pressure too high. 	<ol style="list-style-type: none"> 1. Readjust float arm. 2. Repair or replace. 3. Reduce pressure or contact Conair for alternate solutions.
Uneven water level in tower basins of multi-cell installations (For Side Outlet Models)	<ol style="list-style-type: none"> 1. Unbalanced system hydraulics. 2. More than one make-up valve operating, and set for different water levels. 	<ol style="list-style-type: none"> 1. <ol style="list-style-type: none"> A. Install equalizer line with isolation valves between modules. B. Adjust inlet water flow to insure equal distribution to each cooling tower module. C. Review outlet header hydraulics and correct piping design, if applicable. D. Contact Conair for assistance. 2. <ol style="list-style-type: none"> A. Adjust float level settings relative To one another. B. Shut-off and or/throttle flow to one or more valves. C. Installation of equalizers is highly recommended.
Excessive water carry over (drift)	<ol style="list-style-type: none"> 1. Surfaces of top layer of fill damaged causing “pooling” of water. 2. Damaged eliminator. 3. Excess water flow causing high sprinkler flow rate. 4. Excess pressure at nozzles. 5. Nozzles are clogged causing improper water dispersion. 6. Blockage of fill. 	<ol style="list-style-type: none"> 1. Replace top layer. Protect fill when working inside tower. 2. Replace. 3. Reduce water flow or install nozzles designed for the actual operating flow. 4. Reduced pressure at inlet to recommended settings. 5. Install outlet strainer. Clean whole system and lateral arms. 6. Clean fill.
Premature or excessive corrosion of fan drive components	<ol style="list-style-type: none"> 1. Presence of corrosive chemicals in air or water that was not known at time of supply. 	<ol style="list-style-type: none"> 1. Remove source of corrosion or contact Conair for alternative materials, premium coatings or other precautions.

Motor Trouble Shooting Guide (General)

Problem	Possible Causes	Corrective Actions
High current draw (all 3 phases)	<ol style="list-style-type: none"> 1. Low line voltage (5 to 10% lower than nameplate). 2. 200V motor on 230/240V system. 3. 230V motor on 208V system. 4. Incorrect blower. 5. Water not circulating through the cooling tower. 	<ol style="list-style-type: none"> 1. Consult power company. 2. Change to 230V motor. 3. Change to 200V or 280V motor. 4. Consult factory. 5. Circulate water while running blower.
Low motor current draw	<ol style="list-style-type: none"> 1. Incorrect propeller. 2. Incorrect pitch if adjustable. 	<ol style="list-style-type: none"> 1. Consult factory 2. Increase pitch / consult factory
Unbalanced current (5% from average)	<ol style="list-style-type: none"> 1. Unbalanced line voltage due to: <ol style="list-style-type: none"> A. Power supply. B. Unbalance system loading. C. High resistance connection. D. Undersized supply lines. 2. Defective Motor. 	<ol style="list-style-type: none"> 1. Consult power company and/or electrician. 2. Replace motor.
Excessive voltage drop (2 or 3% of supply voltage)	<ol style="list-style-type: none"> 1. Inadequate power supply. 2. Undersized supply lines. 3. High resistance connections. 	<ol style="list-style-type: none"> 1. Consult power company. 2. Increase line sizes. 3. Check motor leads and other connections.
Overload relays tripping	<ol style="list-style-type: none"> 1. Overload. 2. Unbalanced input current. 3. Single phasing. 4. Excessive voltage drop. 5. Frequent starting or intermittent overloading. 6. High ambient starter temperature. 7. Wrong size relays. 8. Improper overload settings of adjustable relays. 	<ol style="list-style-type: none"> 1. Reduce load on motor or increase motor size. 2. Balance supply voltage. 3. Eliminate. 4. Eliminate (see above). 5. Reduce frequency of starting and overloading or increase motor size. 6. Reduce ambient temperature. 7. Correct size per nameplate current and service factor. 8. Readjust to motor FL Amps x S.F.
Motor runs very hot	<ol style="list-style-type: none"> 1. Overloaded. 2. Blocked ventilation. 3. High ambient temperature. 4. Unbalanced input current. 5. Single phased. 	<ol style="list-style-type: none"> 1. Reduce overload. 2. Fouled fill or air restriction. 3. Reduce ambient temperature. 4. Balanced supply voltage. 5. Eliminate.
Motor will not start	<ol style="list-style-type: none"> 1. Single phased. 2. Rotor or bearings locked. 	<ol style="list-style-type: none"> 1. Shut power off – eliminate. 2. Shut power off – check shaft rotation.
Excessive vibration (Mechanical)	Out of balance <ol style="list-style-type: none"> 1. Motor mounting. 2. Motor. 	<ol style="list-style-type: none"> 1. Check to be sure motor mounting hardware is tight. 2. Replace motor.

Note: Consult Warranty, page prior to replacing or repairing any cooling tower components. Conair recommendation

and consent to remedy material and workmanship defects is necessary, to avoid breach of Warranty.

OPTIONAL ACCESSORIES

Conair Optional Accessories Available:

- ❑ Platform.
- ❑ Skid Mounting Assembly.
- ❑ Two-speed motor(s) designed for cooling tower duty to the exclusive specifications of Conair Cooling Towers.
- ❑ One or two-stage fan thermostat on/off control of fan operation through sensing the temperature of water leaving the tower.
- ❑ Vibration cutout switch provides for fan motor circuit disconnect for shutdown protection should abnormal fan vibration develop during service. Installation of vibration cutout switches is recommended as good design practice.
- ❑ Basin anti-freeze system for cold weather operation.
- ❑ Plastic equalizer fittings.
- ❑ Automatic drain valve.
- ❑ Outlet strainer basket.
- ❑ Flanged Adapters.
- ❑ High sump level switch.
- ❑ Airflow switch.
- ❑ Mastic coating of Blower Assembly.
- ❑ Premium blower corrosion protection.
- ❑ Elevated mounting frame structures.
- ❑ Variable frequency drive on fan motors controlled by temperature controller.

Consult factory or a Conair representative for further information and an updated list of accessories.

ACCESSORIES DESCRIPTION

Platform (see dwg. no. DT-C-79-507) – The platform is a desirable option when a flat smooth uniform surface is not available for mounting Conair's cooling towers.

The platform must be mounted and supported in accordance with Conair's recommendations.

This option includes a steel mounting platform finished in a black semi-gloss alkyd paint.

Skid Mounting Assembly - The skid mounting assembly is a desirable option which minimizes the field labor required to install an E1 cooling tower.

Included with this option is a steel mounting platform finished in a black semi-gloss alkyd paint, with the cooling tower and blower assembled and mounted to the platform.

Additional options can readily be mounted onto the platform to complete the factory assembly.

Two Speed Fan Motor – Two speed fan motors provide cold water temperature control by means of airflow modulation, allowing for design cold water temperature at minimum operating cost.

When provided with a two-stage thermostat, the motor can be reduced to half speed when cold water sump temperature approaches design. The motor will shut off when the cold water temperature falls below design.

Two-speed TEFC motors are provided for single voltage, 3-phase operation only. Single phase, dual-voltage motors are not available.

Please refer to the Blower thermostat option data sheet below.

Single Stage and Two-Stage Fan Thermostats – The fan thermostat is important to minimize operating costs. The thermostat senses water temperature and controls fan operation during cold weather service. When cold water temperature drops below design, the fan will shut off, saving motor hp operating costs.

A single-stage thermostat controls the fan on and off and is provided with standard single speed motors.

A two-stage thermostat is required for two-speed motor operation and controls the fan from “on” to “half speed” and then to “off”. Two-stage thermostats must be wired to Conair specifications (see dwg. no. DT-B-78-005).

As the cold water temperature rises and approaches the design temperature, the thermostat signals the fan to start in order to maintain the cold water design temperature. The thermostat has a 5° differential in its operating range of 30°F to 130°F. The contacts are SPDT and have a 15 Amp UL rating. Thermostat operating range must be set in the field. Recommended setting is approximately 70° to 72° F, but will vary depending on the application and the installation location. They are complete with NEMA 4 enclosures suitable for outdoor mounting.

The thermostat can be provided loose, installed in the cooling tower sump, or in an indoor storage tank.

When the thermostat is supplied with a cooling tower or storage tank provided by Conair, the package includes installation with a ¾” schedule 80 PVC bulkhead fitting and a ¾” x ½” schedule 40 PVC reducer bushing.

Vibration Cut-Out Switch (see dwg. no. DT-A-80-517) - The vibration cut-out switch option is utilized to shut down the rotating mechanical fans in the event of excessive vibration. Excessive vibration can be caused by worn or failed bearings, a bent shaft, or propeller imbalance.

This device helps prevent further potential damage by shutting the motor off. It is wired in series with the motor starter coil and has a dry contact rating of 10 ampere capacity at 120 VAC.

Conair provides the vibration cut-out switch installed on the fan when ordered as a component of a new cooling tower or on a replacement fan assembly.

Antifreeze Package – Resistance Heating Option (see dwg. no. DT-B-78-010) – The antifreeze package is supplied to provide protection against freezing of standing water in the cooling tower sump due to shutdown during winter operation.

This option is provided when draining the system during periods of prolonged shutdown is not feasible, such as during weekends, or when a separate gravity feed indoor storage tank is not part of the recirculation system.

Protection is provided by resistance heating of the sump water. This package includes the following components:

Immersion heater – Capacity sized for service. NEMA 4 enclosure.

E10-E25: 2000 watt – 2” thread

E30-E40: 4500 watt – 2.5” thread

E50-E75: 6000 watt – 2.5” thread

Thermostat Assembly – NEMA 4 enclosure with SPDT switch. 30-130°F temperature range. 120/277 Volt with ¾” Sch 80 bulkhead fitting and a ¾” x ½” Sch 40 reducer. Thermostat is to be set in the field. Recommended setting is approximately 38°F.

Liquid Level Switch Assembly – NEMA 7 and 9 enclosure is standard on this SPDT level switch. This insures that the heating element is submerged prior to energizing to prevent immersion heater burn-out in case of low water level.

Heater Contactor – NEMA 1 enclosure is standard. Open style for control panel mounting is available. This contactor is mounted in the control panel when the panel is purchased from Conair.

See dwg. no. DT-B-78-001 for wiring schematic.

PVC bulkhead fittings, for local installation, are included in component prices.

Protection of external piping by heat tracing and insulation is recommended but not included.

Equalizer Fittings – This option is desirable for multiple module installations to provide equal liquid levels in the sumps of the individual modules and allows for the installation of only one water make-up line.

Conair provides the bulkhead fittings installed in the cooling towers to provide for gravity flow from one tower sump to another. The equalizer connection is not for full flow transfer, ie; pumping from one unit to another.

The connecting piping should be field installed and is the responsibility of others.

Antifreeze Package Solenoid Drain Valve Option (see dwg. no. DT-B-78-008) – This option is utilized when freezing of standing water in the cooling tower sump could occur due to system shutdown during winter operation.

An electrically actuated valve will open when the pumps are not operating and temperatures approach freezing. The valve can be installed in the sump drain

fitting of the tower at the factory or remotely at the piping low point by others in the field.

Components provided are:

- A) Electrically actuated to close, spring to open, 2-way valve, 1" line size, with NEMA 4 enclosure.

When power is removed the valve automatically reverts to the open position. This feature ensures freeze protection even during a power outage.

- B) 1" PVC tee
- C) 1" PVC plug
- D) Temperature switch with bulkhead fitting.

Outlet Strainer Basket – This option is desirable to prevent debris that may have entered the cooling tower sump from getting into the pump, or the rest of the cooling water system. This option is recommended to minimize particle size which could foul chillers, heat exchangers, compressors or the cooling tower distribution laterals.

A vortex breaker pipe, which provides as standard on pump suction applications, is included to maximize the inlet area and prevent cavitation. The strainer is made from a vortex breaker pipe surrounded by 3/16" #2 PVC coated mesh screen.

Finer mesh screens can be overlaid to minimize particle size. Consult Conair to for prices and availability.

Flanged Adapters – Standard inlet and outlet fittings are PVC socket connections.

This option provides 125 lb. Schedule 80 PVC flanged connection at approximately 6" projection minimum from the cooling tower.

Gasket and hardware are not provided by Conair and should be provided by others with the piping companion flange.

High Sump Level Switch (see dwg. no. DT-B-78-009) – The high sump level switch option is utilized when a potential overflow condition must be avoided.

Switch elevation is set below the point when the water in the sump will overflow onto the ground.

The switch can be used to illuminate a light, shut off the influent feed pump or initiate some other device or alarm.

This package consists of NEMA 7 & 9 liquid level switch mounted in a PVC bulkhead fitting assembly with 2" x 1" reduced bushing.

Airflow Switch – The airflow switch is desirable when loss of airflow will have an adverse affect on system operation.

This switch will indicate loss of airflow from many causes including, by not limited to belt slippage, belt failure, motor failure, thermal overload shutdown, media failure, etc.

The airflow switch is an on/off device that can be operated in tow modes:

- A.) Will indicate total loss of airflow as installed at the factory, or
- B.) Can indicate loss of a limited amount of airflow by varying the insertion depth of the sensing elements.

The enclosure is rated NEMA 7 & 9 as standard.

The contacts have a rating of 5 amperes at 125/250 VAC and are SPDT.

It can be utilized for system shutdown, warning lights or other functions.

Mastic Coating of Blower Assembly – Mastic coating of the blower wheel, housing and frame is desirable when additional corrosion protection is required. The mastic coating is applied directly over the standard enamel finish. This option is recommended in areas of continuous high humidity. It also provides protection from corrosive compounds, acids, etc.

The material used is a brush on, solvent based asphaltic film coating which is impervious to standing water and airborne spray.

Mastic coating has proven successful in prolonging the average life of a standard blower assembly.

After final assembly, the blower shaft and sheaves are coated with a special shaft coating material. This coating conforms to MIL-C-16173D, GR 1 & 4.

For best results, periodic recoating of both the wheel and housing are recommended.

Premium Blower Corrosion Protection – Premium blower corrosion protection is desirable when the unit will be operated in highly corrosive atmospheres such as paper mills, coastal areas, chemical plants, etc.

The premium blower corrosion protection option consists of complete PVC encapsulation of the blower wheel and housing and frame. A T-304 stainless steel shaft is also included.

This option offers an extremely cost effective alternative to FRP blower assemblies.

The blowers and frames are prepared at the factory with all holes and cutouts completed. The entire assembly is sandblasted, then dipped in a molten PVC solution which coats the entire surface. When dry, the PVC attains an average thickness of 30 mils and forms a complete covering of the standard frame and housing. The blower wheel is coated in the same manner, except for the shaft bore, and is then re-balanced both statically and dynamically. After final assembly, the shaft and sheaves are coated with a specially formulated shaft coating material, which conforms to MIL-C-16173D, GR 1&4.

The result is a blower assembly which will give years of corrosion free service even under the most adverse conditions.

CONAIR RECOMMENDED REPLACEMENT PARTS

To avoid costly cooling tower downtime, the following replacement parts should be carried in inventory at the installation site:

- Make-up float, or complete make-up valve assembly.
- V-belts
- Blower bearings
- Blower shaft
- Blower motor
- Or, a complete blower assembly including bearings, shaft, sheaves, V-belts and motor.

When ordering, include model number and serial number of the cooling tower as it appears on the tower nameplate. Under normal conditions, shipment of factory replacement parts is made within one day after the order is received. Spare pumps and pump parts, as well as control panel components, such as fuses and heaters for magnetic starters, are also available.

Appendices/ Reference Documents

Check Box for items included with IOM package

Conair Drawings

- | | |
|--------------------------------------|--|
| <input type="checkbox"/> DT-D-79-507 | Platform |
| <input type="checkbox"/> DT-D-78-100 | E1-10 thru E1-25 Assembly |
| <input type="checkbox"/> DT-D-78-200 | E1-30 thru E1-40 Assembly |
| <input type="checkbox"/> DT-D-78-300 | E1-50 thru E1-75 Assembly |
| <input type="checkbox"/> DT-B-78-001 | Wiring Schematic, 3 phase |
| <input type="checkbox"/> DT-B-78-004 | High Sump Level Switch Installation Instructions |
| <input type="checkbox"/> DT-B-78-005 | Wiring Schematic, 2 speed |
| <input type="checkbox"/> DT-B-78-006 | Wiring Schematic, 1 phase |
| <input type="checkbox"/> DT-B-78-007 | Fan control installation instructions |
| <input type="checkbox"/> DT-B-78-008 | Wiring Automatic Drain |
| <input type="checkbox"/> DT-B-78-009 | Wiring High Sump Level Switch |
| <input type="checkbox"/> DT-B-78-010 | Heater Support Detail |
| <input type="checkbox"/> DT-B-79-523 | Anti-freeze Automatic Drain Valve |
| <input type="checkbox"/> DT-B-86-040 | Antifreeze Immersion Heater Package |
| <input type="checkbox"/> DT-B-86-041 | Fan Thermostat |
| <input type="checkbox"/> DT-A-80-517 | Vibration Switch |

Preventative Maintenance Checklist

MONTHLY:

- ☛ Inspect General Condition of cooling tower.
- ☛ Check Water Level in cold water basin. Adjust if needed.
- ☛ Check float ball & Make-up Valve for proper operation. If furnished.
- ☛ Check Line Voltage, Motor Amperage, and Drift Eliminator.
- ☛ Check belt tension and general condition of V-belts.

EVERY 3 MONTHS:

- ☛ Clean outside of blower motor to help assure proper cooling.
- ☛ Lubricate blower bearings and fan motor using a low pressure grease gun.
- ☛ Check blower wheel for dirt buildup which can cause unbalance and vibration.

EVERY 6 MONTHS:

- ☛ Clean and flush cold water basin
- ☛ Lubricate motor base and adjusting screw.

We're Here to Help

Conair has made the largest investment in customer support in the plastics industry. Our service experts are available to help with any problem you might have installing and operating your equipment. Your Conair sales representative also can help analyze the nature of your problem, assuring that it did not result from misapplication or improper use.

Additional manuals and prints for your Conair equipment may be ordered through the Customer Service or Parts Department for a nominal fee.

How to Contact Customer Service

To contact Customer Service personnel, call:



NOTE: Normal operating hours are 8:00 am - 5:00 pm EST. After hours emergency service is available at the same phone number.

From outside the United States, call: 814-437-6861

You can commission Conair service personnel to provide on-site service by contacting the Customer Service Department. Standard rates include an on-site hourly rate, with a one-day minimum plus expenses.

Before You Call...

If you do have a problem, please complete the following checklist before calling Conair:

- Make sure you have all model, control type from the serial tag, and parts list numbers for your particular equipment. Service personnel will need this information to assist you.
- Make sure power is supplied to the equipment.
- Make sure that all connectors and wires within and between control systems and related components have been installed correctly.
- Check the troubleshooting guide of this manual for a solution.
- Thoroughly examine the instruction manual(s) for associated equipment, especially controls. Each manual may have its own troubleshooting guide to help you.
- Check that the equipment has been operated as described in this manual.
- Check accompanying schematic drawings for information on special considerations.

Equipment Guarantee

Conair guarantees the machinery and equipment on this order, for a period as defined in the quotation from date of shipment, against defects in material and workmanship under the normal use and service for which it was recommended (except for parts that are typically replaced after normal usage, such as filters, liner plates, etc.). Conair's guarantee is limited to replacing, at our option, the part or parts determined by us to be defective after examination. The customer assumes the cost of transportation of the part or parts to and from the factory.

Performance Warranty

Conair warrants that this equipment will perform at or above the ratings stated in specific quotations covering the equipment or as detailed in engineering specifications, provided the equipment is applied, installed, operated and maintained in the recommended manner as outlined in our quotation or specifications.

Should performance not meet warranted levels, Conair at its discretion will exercise one of the following options:

- Inspect the equipment and perform alterations or adjustments to satisfy performance claims. (Charges for such inspections and corrections will be waived unless failure to meet warranty is due to misapplication, improper installation, poor maintenance practices or improper operation.)
- Replace the original equipment with other Conair equipment that will meet original performance claims at no extra cost to the customer.
- Refund the invoiced cost to the customer. Credit is subject to prior notice by the customer at which time a Return Goods Authorization Number (RGA) will be issued by Conair's Service Department. Returned equipment must be well crated and in proper operating condition, including all parts. Returns must be prepaid.

Purchaser must notify Conair in writing of any claim and provide a customer receipt and other evidence that a claim is being made.

Warranty Limitations

Except for the Equipment Guarantee and Performance Warranty stated above, Conair disclaims all other warranties with respect to the equipment, express or implied, arising by operation of law, course of dealing, usage of trade or otherwise, including but not limited to the implied warranties of merchantability and fitness for a particular purpose.