

USER GUIDE
UGH027-1006

Thermolator®

TW Series

Water Temperature Control Units
TW plus, TW-1 and TW-2



Please record your equipment's model and serial number(s) and the date you received it in the spaces provided.

It's a good idea to record the model and serial number(s) of your equipment and the date you received it in the User Guide. Our service department uses this information, along with the manual number, to provide help for the specific equipment you installed.

Please keep this User Guide and all manuals, engineering prints and parts lists together for documentation of your equipment.

Date: _____

Manual Number: UGH027-1006 _____

Serial Number(s): _____

Model Number(s): _____

DISCLAIMER: Conair shall not be liable for errors contained in this User Guide or for incidental, consequential damages in connection with the furnishing, performance or use of this information. Conair makes no warranty of any kind with regard to this information, including, but not limited to the implied warranties of merchantability and fitness for a particular purpose.

TABLE OF CONTENTS

INTRODUCTION1-1

- Purpose of the User Guide1-2
- How the Guide is Organized1-2
- Your Responsibility as a User1-2
- ATTENTION: Read this so no one gets hurt1-3

DESCRIPTION2-1

- What is the Thermolator?2-2
- Typical Applications2-2
- How it Works: Direct Injection2-3
- How it Works: Closed Circuit2-4
- How it Works: Isolated Circuit2-5
- Specifications2-6
- Features and Options2-8

INSTALLATION3-1

- Unpacking the Boxes3-2
- Preparing for Installation3-3
- Connecting Process and Water Supply Lines3-4
- Connecting the Main Power Supply3-5
- Testing the Installation TW Plus Control3-6
- Testing the Installation TW-1, TW-2 Control3-7
- TW Plus Control Initial Setup3-8
- TW Plus Control Changing Temperature Units3-9
- TW-1, TW-2 Control Initial Setup3-10
- TW-1, TW-2 Control Changing Temperature Units3-11
- TW-1, TW-2 Control Passcode Protection3-12
- TW-2 Control Selecting the Temperature Control Point3-14
- TW-1, TW-2 Control Entering Temperature
 - Deviation Alarm Parameters3-16
- TW-2 Control Installing the Auto Start Feature3-17
- Positioning the TW-2 Control Panel3-19

OPERATION4-1

- TW Plus Control Features4-2
- TW Plus Control Menu4-3
- TW-1 Control Features4-4
- TW-2 Control Features4-5
- Starting the TW Plus4-6
- Stopping the TW4-7
- Starting the TW-1, TW-24-8
- Stopping the TW-2, TW-24-9
- Using the TW Plus Purge Option4-10
- Using the TW-1 Purge Option4-11
- Using the TW-2 Purge Option4-12
- TW Plus Control Performing an Auto Tune4-13
- TW-1, TW-2 Control Performing an Auto Tune4-14

TABLE OF CONTENTS

OPERATIONCONT'D
TW-1, TW-2 Control Entering Passcodes	4-16
MAINTENANCE	5-1
Preventative Maintenance Schedule	5-2
Accessing the Thermolator Enclosure	5-3
Checking Reservoir Fluid Levels (IC)	5-4
TW-1, TW-2 Control Performing System Tests	5-5
TW-1, TW-2 Control Key/Display Test	5-6
TW-1, TW-2 Control Input Test	5-7
TW-1, TW-2 Control Output Test	5-8
TW-1, TW-2 Control Output Monitors	5-9
TW-1, TW-2 Control Calibrating Temperature Sensors ..	5-10
TW-1, TW-2 Control Logging Operating Hours	5-12
TW-1, TW-2 Control Pulse Mode Description	5-13
TW-1, TW-2 Control Pulse Mode Setup	5-13
TW-1, TW-2 Control Pulse Mode Limits & Defaults ..	5-14
TW-1, TW-2 Control Deviation Alarm/Inhibition Delay ..	5-14
TW-1, TW-2 Control Vent Timer Adjustment	5-15
TROUBLESHOOTING	6-1
Before Beginning	6-2
A Few Words of Caution	6-2
Identifying the Cause of a Problem	6-3
TW Plus Control Alarms	6-5
TW Plus Control Mechanical/Electrical Alarms	6-11
TW-1, TW-2 Control Shut Down Alarms	6-12
TW-1, TW-2 Control Warning Alarms	6-13
TW-1, TW-2 Control Other Warnings	6-15
TW-1, TW-2 Control System Alarms	6-16
Thermolator Will Not Power Up	6-17
Replacing the TW Plus Control	6-18
Checking and Replacing Fuses	6-19
Resetting Overloads	6-20
Replacing Pump Overload	6-20
Replacing the Motherboard TW-1, TW-2	6-21
Replacing the Heater Contactor	6-22
Checking Thermocouples	6-23
Replacing Thermocouples	6-23
PT1000 Sensor Test Readings TW Plus	6-24
Repairing Cooling Valves	6-25
Repairing Solenoid Valves	6-26
Repairing Modulating Valves	6-27
Replacing Heater Elements	6-28
Removing the Pump	6-30
Disassembling and Assembling 3/4 to 2 HP Pumps	6-31
Disassembling and Assembling 3 to 7.5 HP Pumps	6-32
APPENDIX	
Customer Service Information	A-1
Warranty/Guarantee Information	A-2
Pump Curves	B-1
TW Plus Control Default Parameters	C-1
TW-1, TW-2 SPI Commands and Status Words	D-1
PARTS/DIAGRAMS	
TW-1 Circuit Board	PD-3
TW-2 Circuit Board	PD-4

INTRODUCTION

- *Purpose of the User Guide1-2*
- *How the Guide is Organized . . .1-2*
- *Your Responsibilities as a User 1-2*
- *ATTENTION: Read this so
no one gets hurt1-3*

PURPOSE OF THE USER GUIDE

This User Guide describes the Conair Thermolator® TW Series water temperature controllers and explains step-by-step how to install, operate, maintain and repair this equipment.

Before installing this product, please take a few moments to read the User Guide and review the diagrams and safety information in the instruction packet. You also should review manuals covering associated equipment in your system. This review won't take long, and it could save you valuable installation and operating time later.

HOW THE GUIDE IS ORGANIZED

Symbols have been used to help organize the User Guide and call your attention to important information regarding safe installation and operation.



Symbols within triangles warn of conditions that could be hazardous to users or could damage equipment. Read and take precautions before proceeding.



Numbers within shaded squares indicate tasks or steps to be performed by the user.



A diamond indicates the equipment's response to an action performed by the user.



An open box marks items in a checklist.



A shaded circle marks items in a list.

YOUR RESPONSIBILITY AS A USER

You must be familiar with all safety procedures concerning installation, operation and maintenance of this equipment. Responsible safety procedures include:

- Thorough review of this User Guide, paying particular attention to hazard warnings, appendices and related diagrams.
- Thorough review of the equipment itself, with careful attention to voltage requirements, intended uses and warning labels.
- Thorough review of instruction manuals for associated equipment.
- Step-by-step adherence to instructions outlined in this User Guide.

We design equipment with the user's safety in mind. You can avoid the potential hazards identified on this machine by following the procedures outlined below and elsewhere in the User Guide.

 **ATTENTION:
READ THIS SO NO
ONE GETS HURT**



WARNING: Improper installation, operation or servicing may result in equipment damage or personal injury.

This equipment should be installed, adjusted, and serviced by qualified technical personnel who are familiar with the construction, operation and potential hazards of this type of equipment.

All wiring, disconnects and fuses should be installed by qualified electrical technicians in accordance with electrical codes in your region.

Always maintain a safe ground. A properly sized conductive ground wire from the incoming power supply must be connected to the chassis ground terminal inside the electrical enclosure. Improper grounding can result in personal injury and erratic machine operation.

Do not operate the equipment at power levels other than what is specified on the the equipment serial tag and data plate.



WARNING: Electrical shock hazard

This equipment is powered by three-phase main voltage, as specified on the machine serial tag and data plate.

Always disconnect and lock out the incoming main power source before opening the electrical enclosure or performing non-standard operating procedures, such as troubleshooting or maintenance. Only qualified personnel should perform procedures that require access to the electrical enclosure while power is on.



CAUTION: Hot surfaces

Surface temperatures inside the Thermolator can exceed 250°F (121°C). Always allow the unit to cool to below 100°F (38°C) before opening, servicing or disassembling the unit.

 **ATTENTION:**
READ THIS SO NO
ONE GETS HURT



WARNING: Hazardous substance

The contactors used in the Thermolator are mercury displacement relays. Mercury is considered a hazardous substance and must be dealt with accordingly. See the Material Safety Data Sheet which explains the potential hazards, how to avoid them and how to clean up and dispose of the mercury if it spills.

DESCRIPTION

- ***What is the Thermolator
TW Plus Series?2-2***
- ***Typical Applications2-2***
- ***How it Works:***
 - Direct Injection (DI) Models . . .2-3***
- ***How it Works:***
 - Closed Circuit (CC) Models2-4***
- ***How it Works:***
 - Isolated Circuit (IC) Models2-5***
- ***Specifications2-6***
- ***Features and Options2-8***

WHAT IS THE THERMOLATOR?

The Thermolator TW models circulate water at a temperature higher than the available water supply, to add or remove heat as needed to maintain a uniform temperature setpoint in the process.

Conair TW Thermolators are available in single or dual-zone configurations, using resistance heating and direct injection or closed circuit cooling. Dual-zone models can control at two different temperatures at different locations in the process. Two-zone models have common cooling water manifolds and electrical connections.

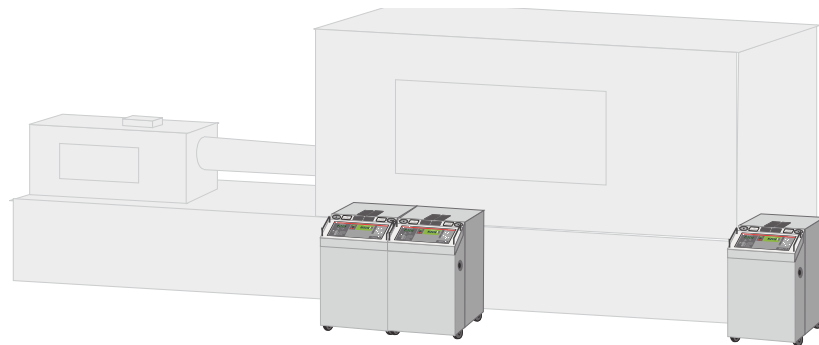

TYPICAL APPLICATIONS

IMPORTANT: Do not use deionized water or glycol mixtures containing additives in a Thermolator. Softened water or glycol mixtures with additives, such as automotive fluids, can damage the Thermolator. Glycol/water process loop mixtures should use industrial-grade ethylene glycol only.

The best model for your application depends on the process temperature you need to maintain and the quality of the cooling water supply.

Direct injection (DI) models control the temperature by discharging heated process water and adding cooling water directly from the water supply. DI models are designed for:

- Process temperatures up to 250°F (121°C).
- Use with chiller water or properly treated and filtered tower or city water.

Closed circuit (CC) models add cooling water to the process loop only during the initial filling or when make-up water is needed. CC models are recommended for:

- Process temperatures up to 250°F (121°C).
- Use with contaminated cooling water.

Isolated circuit (IC) models separate the cooling water from the process fluid, which is held in a reservoir. IC models are recommended for:

- Process temperatures up to 180°F (82°C).
- Use with contaminated cooling water.
- When process and cooling fluids are different.

Direct injection models maintain the process temperature by electrically heating and injecting cool water supplied to the Thermolator by a chiller, tower or other water source.

HOW IT WORKS: DIRECT INJECTION

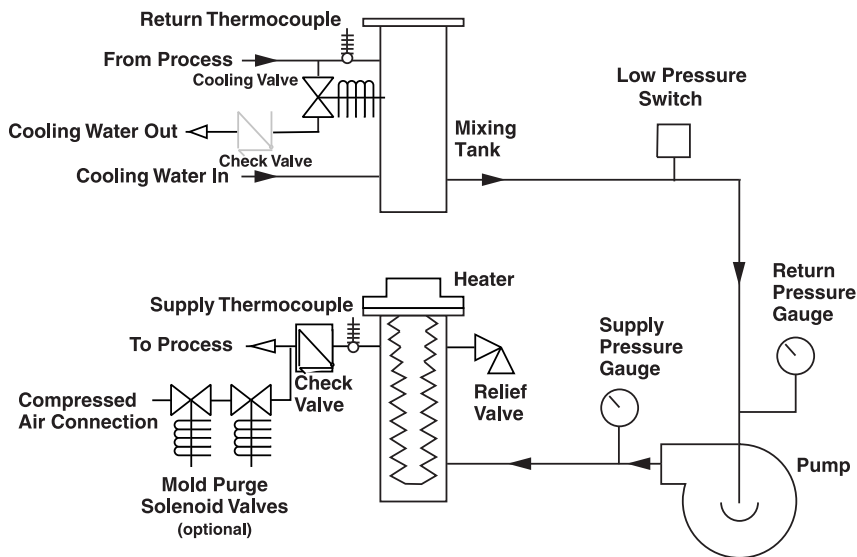
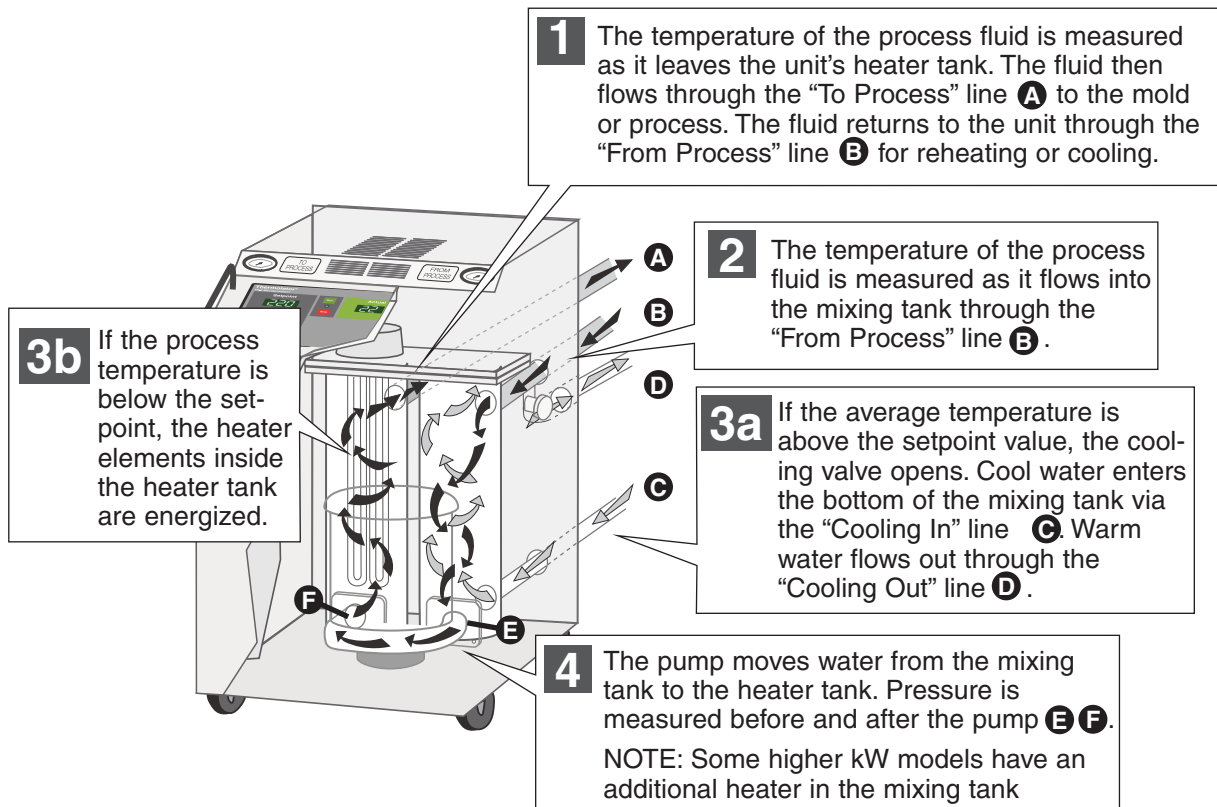

Direct Injection

Check valves included only with mold purge feature.

How It Works: CLOSED CIRCUIT

Closed Circuit models maintain the process temperature by electrically heating and indirectly cooling fluid in the process circuit. Cooling water supplied by a chiller, tower or other water source, is mixed with the process fluid only during the initial filling or when water is needed to make up process fluid loss.

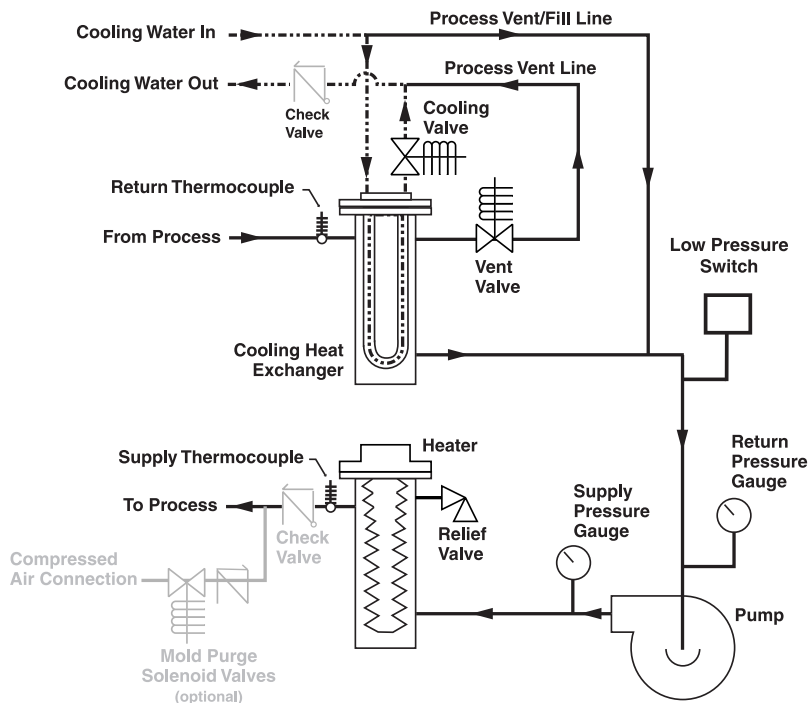
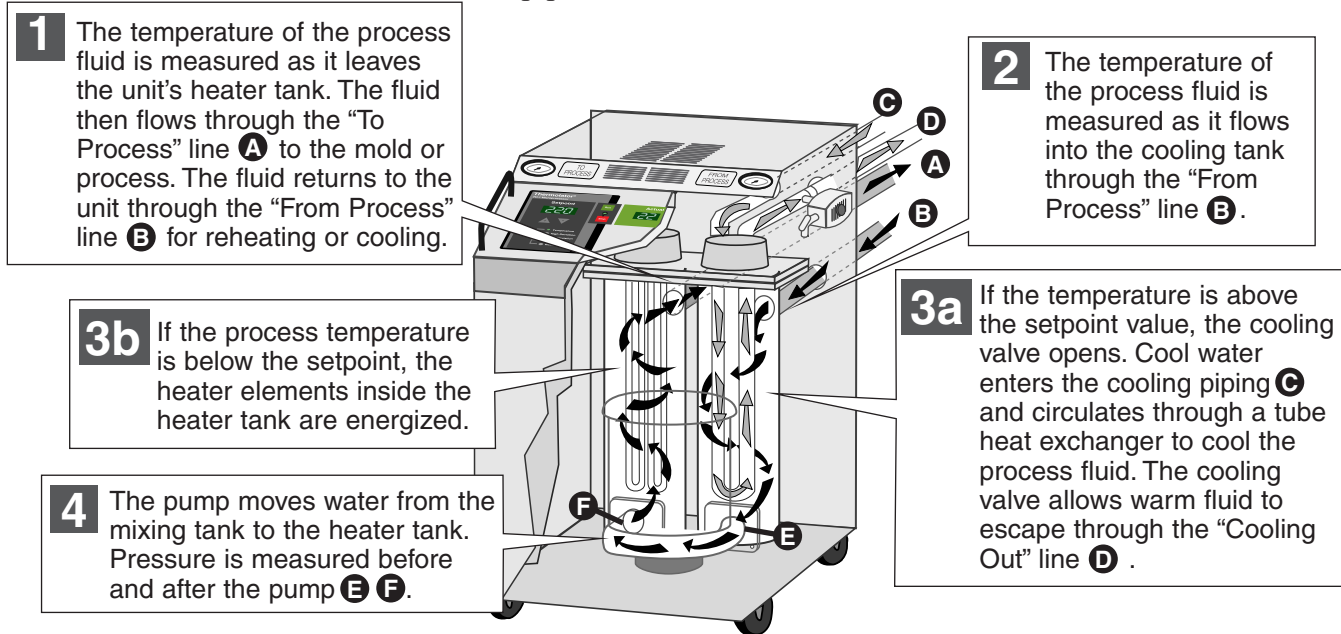

Closed Circuit

Check valves included only with mold purge feature.

Isolated Circuit models maintain the process temperature by electrically heating and indirectly cooling fluid in the process circuit. The process fluid, which is stored in a reservoir, is isolated from cooling water supplied by a chiller, tower or other source.

How It Works: ISOLATED CIRCUIT

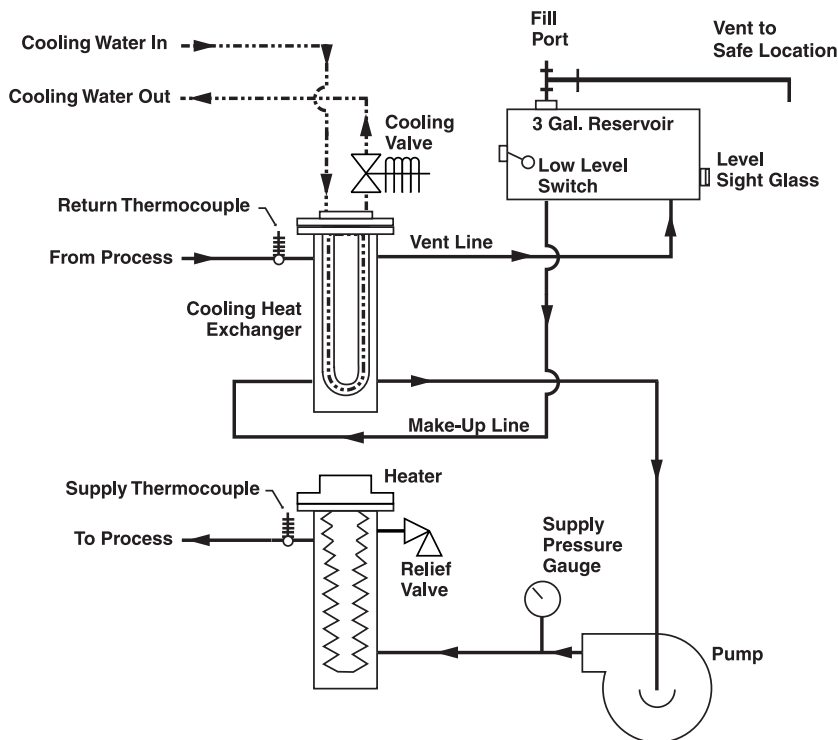
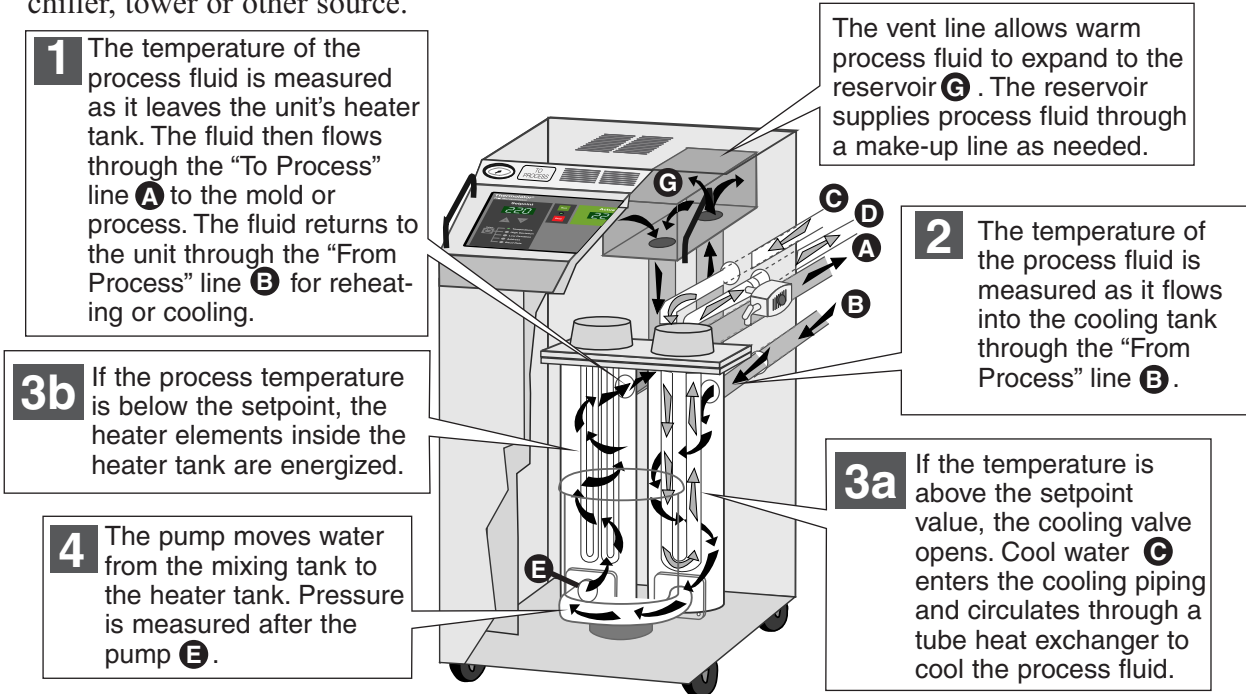

Isolated Circuit

NOTE: There is a 180° F operating temperature limit on isolated circuit units.

SPECIFICATIONS

Dimensions and performance characteristics vary according to the model, voltage and components selected. See the cabinet style reference chart to determine dimensional information for your specific model. Additional technical information can be found in the Appendix of this User Guide.

CABINET STYLE REFERENCE			
Heater	Voltage Selection	Single Zone	Dual Zone
Direct Injection (DI)			
9, 12, 18 or 24 kW	208, 230, 460, 575	A	B
36 kW	230	C	D
36 kW	460 or 575	A	B
48 kW	230, 460, 575	C	D
Closed Circuit (CC)			
9 or 12 kW	208, 230, 460, 575	A	B
18 or 24 kW	208, 230, 460, 575	C	D
Isolated Circuit (IC)			
9, 12, 18 or 24 kW	208, 230, 460, 575	C	D

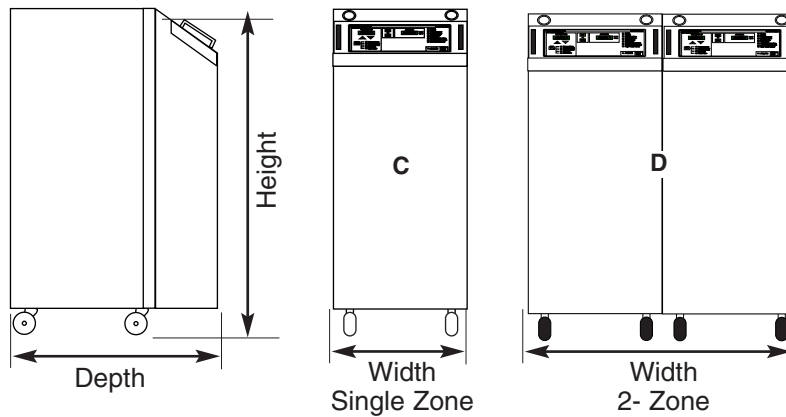
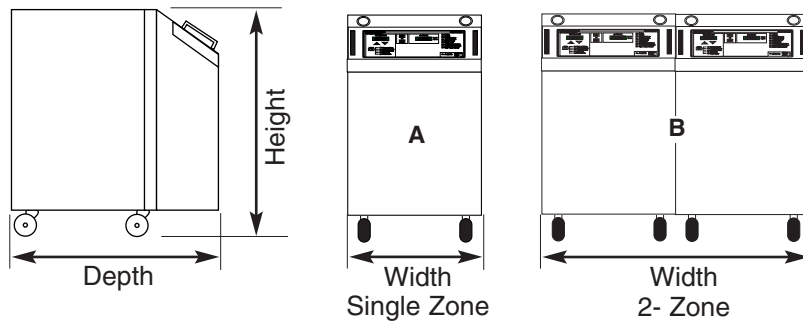

WATER CONNECTIONS	
All models	
NPT inches (female)	
To/From process	1.25
Cooling water in/out	0.75

NOTE: Dual zone models have common wiring and cooling water plumbing.

MODEL DESIGNATIONS

SPECIFICATIONS

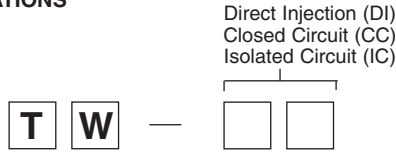

PERFORMANCE CHARACTERISTICS - *Lower operating temperatures can be obtained with larger cooling valves. Consult your Conair representative.			
Models	TW-DI	TW-CC	TW-IC
Minimum Setpoint Temperature °F {°C}	32 {0}	32 {0}	32 {0}
Maximum Setpoint Temperature °F {°C}	250 {121}	250 {121}	180 {82}
Minimum Operating Temperature °F {°C}	Approximately 20° {11°} above the cooling water inlet temperature*		
Standard Cooling Valve Size inches {mm}	1/4 {6.35}	3/4 {19.05}	3/4 {19.05}
Available pump sizes	0.75, 1, 2, 3, 5 or 7.5 Hp {0.56, 0.75, 1.49, 2.24, 3.73 or 5.59 kW}		
Available heater sizes	9, 12, 18, 24, 36 or 48 kW		

PUMP PERFORMANCE - Consult your Conair representative for pump performance characteristics at other operating points.						
Pump	3/4 HP {0.56 kW}	1 HP {0.75 kW}	2 HP {1.49 kW}	3 HP {2.24 kW}	5 HP {3.73 kW}	7.5 HP {5.59 kW}
Nominal Flow gpm {lpm}	40 {151}	45 {170}	55 {208}	80 {303}	100 {379}	115 {435}
Pressure@ Nominal Flow psi {kg/cm²}	17 {1.2}	18 {1.3}	31 {2.2}	35 {2.5}	43 {3}	51 {3.6}

DIMENSIONS in. {mm}				
Cabinet Style	A	B	C	D
Height	28.0 {710}	28.0 {710}	43.0 {1090}	43.0 {1090}
Depth	22.5 {570}	22.5 {570}	31.5 {800}	31.5 {800}
Width	13.75 {350}	27.5 {700}	14.0 {355}	28.0 {710}

SHIPPING WEIGHT RANGES lbs {kg} Weights vary depending on cabinet size and cooling type (DI, CC or IC).				
Pump	Single Zone		Dual Zone	
	Min	Max	Min	Max
0.75 HP {0.56 kW}	240 {109}	300 {136}	480 {218}	600 {272}
1 HP {0.75 kW}	240 {109}	300 {136}	480 {218}	600 {272}
2 HP {1.49 kW}	250 {113}	310 {141}	500 {226}	620 {282}
3 HP {2.24 kW}	260 {118}	320 {145}	520 {236}	640 {290}
5 HP {3.73 kW}	270 {122}	330 {150}	540 {244}	660 {300}
7.5 HP {5.59 kW}	280 {127}	340 {154}	560 {254}	680 {308}

TOTAL FULL LOAD AMPS PER ZONE All voltages are 3 phase, 60 Hz.																								
Heater	9 kW				12 kW				18 kW				24 kW				36 kW				48 kW			
	Voltage	208V	230V	460V	575V	208V	230V	460V	575V	208V	230V	460V	575V	208V	230V	460V	575V	208V	230V	460V	575V	208V	230V	460V
Pump																								
0.75 HP {0.56 kW}	28.9	26.2	13.1	10.5	37.3	33.8	16.9	13.5	54.0	48.8	24.4	19.5	70.7	64.0	32	25.6	104.0	94.0	47.0	37.6	137.0	124.0	62.1	49.7
1 HP {0.75 kW}	29.4	26.6	13.3	10.6	37.8	34.2	17.1	13.7	54.4	49.2	24.6	19.7	71.2	64.4	32.2	25.8	104.3	94.4	47.2	37.8	137.7	124.6	62.3	49.6
2 HP {1.49 kW}	31.8	28.8	14.4	11.5	40.2	36.4	18.2	14.6	56.8	51.4	25.7	20.6	73.6	66.6	33.3	26.6	106.7	96.6	48.3	38.6	140	126.8	63.4	50.7
3 HP {2.24 kW}	34.7	31.4	15.7	12.6	43.1	39.0	19.5	15.6	59.7	54.0	27.0	21.6	76.5	69.2	34.6	27.7	109.6	99.2	49.6	39.7	143	129.4	64.7	51.8
5 HP {3.73 kW}	38.5	34.8	17.4	13.9	46.9	42.4	21.2	17.0	63.4	57.4	28.7	23	80.2	72.6	36.3	29.0	113.4	102.6	51.3	41.0	146.7	132.8	66.4	53.1
7.5 HP {5.59 kW}	45.7	41.4	20.7	16.6	54.1	49.0	24.5	19.6	70.7	64.0	32.0	25.6	87.5	79.2	39.6	31.7	120.7	109.2	54.6	43.7	154	139.4	69.7	55.8

TOTAL FULL LOAD AMPS PER ZONE All voltages are 3 phase, 60 Hz.						
Heater	0 heaters					
Voltage	208V	230V	460V	575V		
Pump					NOTE: Thermolators can be ordered without heaters for certain applications.	
0.75 HP {0.56 kW}	3.9	3.6	2.3	1.5		
1 HP {0.75 kW}	4.4	4.0	2.5	1.6		
2 HP {1.49 kW}	6.8	6.2	3.6	2.5		
3 HP {2.24 kW}	9.7	8.8	4.9	3.6		
5 HP {3.73 kW}	13.5	12.2	6.6	4.9		
7.5 HP {5.59 kW}	20.7	18.8	9.9	7.6		

FEATURES AND OPTIONS

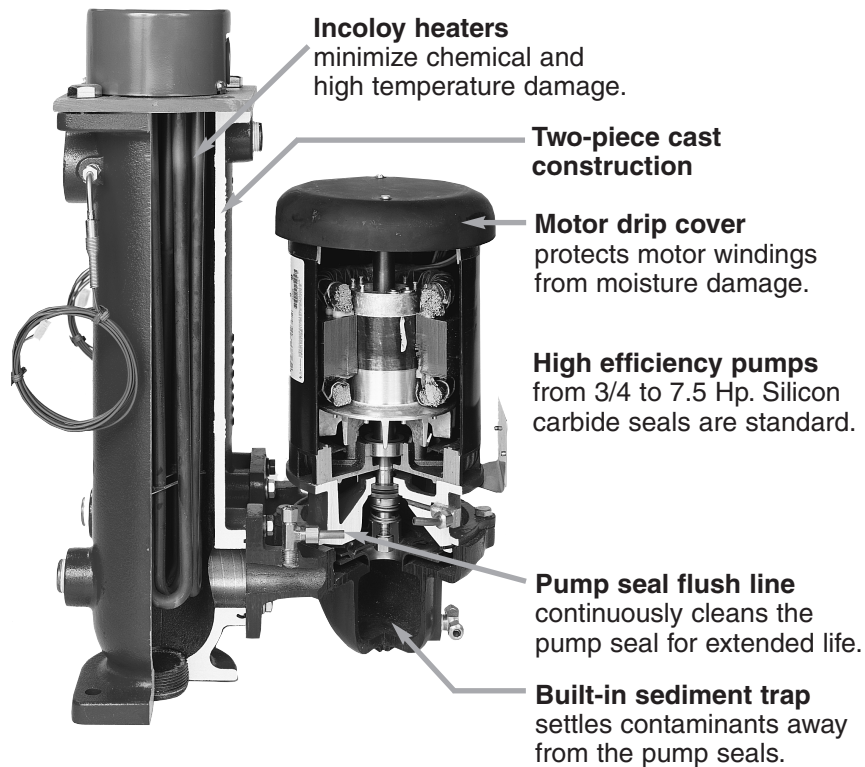

OPTIONS



Modulating Cooling Valve

Slow open/close cycle time eliminates thermal shock and water hammer from your process circuit.



Compressed Air Mold Purge

Quickly evacuates fluid from the process circuit, allowing for faster, cleaner disconnection of the temperature controller from molds and hoses.



Alarm packages

Add an audible or visual alarm to call attention to alarm conditions.



Stacking Rack

Save floor space by stacking Thermolators two-high. The stacking rack can be used only with single-zone models in 28-inch high cabinets.

INSTALLATION

- **Unpacking the Boxes**3-2
- **Preparing for Installation**3-3
- **Connecting Process and
Water Supply Lines**3-4
- **Connecting the Main Power**3-5
- **Testing the Installation**
 - TW Plus Control**3-6
- **Testing the Installation**
 - TW-1, TW-2 Controls**3-7
- **TW Plus Control Initial Setup**3-8
- **TW Plus Control Changing**
 - Temperature Units**3-9
- **TW-1, TW-2 Control Initial Setup** ...3-10
- **TW-1, TW-2 Control Changing**
 - Temperature Units**3-11
- **TW-1, TW-2 Control Enabling and
Disabling Passcode Protection** ...3-12
- **TW-2 Selecting the Temperature
Control Point**3-14
- **TW-1, TW-2 Control Entering
Temperature Deviation Alarm
Parameters**3-16
- **TW-2 Control Installing the
Auto Start Feature**3-17
- **Positioning the TW-2
Control Panel**3-19

UNPACKING THE BOXES

Thermolator TW models come fully assembled. If they were specified at the time of the order, the purge valve or motorized cooling valve is factory-installed.



Thermolator

- 1** Carefully remove the Thermolator and components from their shipping containers.
- 2** Remove all packing material, protective paper, tape and plastic. Check inside the electrical enclosure and behind the side panels for accessories or hardware that may have been placed there for shipping.
- 3** Carefully inspect all components to make sure no damage occurred during shipping, and that you have all the necessary hardware. If damage is found, notify the freight company immediately.
- 4** Take a moment to record serial numbers and specifications in the blanks provided on the back of the User Guide's title page. The information will be helpful if you ever need service or parts.
- 5** You are now ready to begin installation. Complete the preparation steps on the next page.

The Thermolator is easy to install, if you plan the location and prepare the area properly.

PREPARING FOR INSTALLATION

- 1 Position the Thermolator as close to the process machine as possible.**

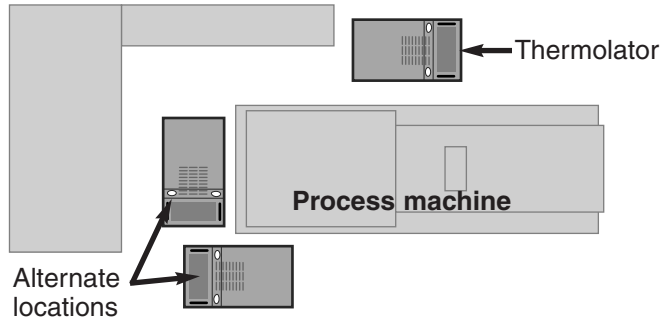

- 2 Make sure the installation area provides:**

- ❑ **A three-phase power source supplying the correct current for your Thermolator model.** Check the serial tag on the side of the electrical enclosure for the required voltage, phase, frequency, full load amps. Field wiring should be completed by qualified personnel to the planned location for the Thermolator. All electrical wiring should comply with your region's electrical codes.

- ❑ **A clean, well-ventilated environment.**

The room temperature should not exceed 120°F (48°C) with 95% non-condensing humidity and should not fall below 32°F (0°C).

- ❑ **Minimum clearance for safe operation and maintenance.** The diagram at right shows minimum clearance for operation. You also need enough clearance in the rear for water hookups. For maintenance, you should move the Thermolator to provide at least 36 inches on any side of the Thermolator.

- ❑ **A source of water for cooling.**

City, tower or chiller water may be used. The minimum supply pressure is 25 psi and the maximum pressure is shown in the following chart.

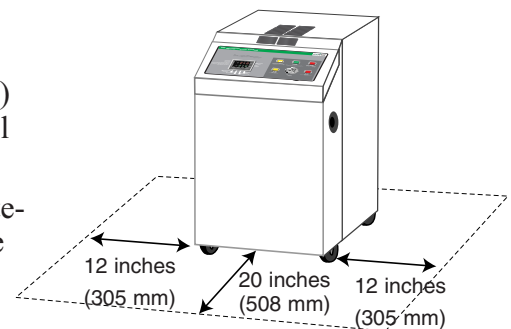

- 3 Install plumbing for process and cooling lines.**

You will need two 1¹/₄-inch NPT male fittings for the process inlet and outlet and two 3/4-inch NPT male fittings for the cooling inlet and outlet. Larger line sizes are acceptable as long as they are reduced at the Thermolator connections. Smaller line sizes are not recommended.

Pump HP	Max Cooling
3/4 HP	95 PSI
1	85
2	70
3	70
5	60
7 1/2	50

CONNECTING PROCESS AND WATER SUPPLY LINES

Tools for installation:

- Pipe wrench large enough for a 2-inch pipe
- Premium quality Teflon thread sealant

NOTE: We recommend that you install an external ball valve on the cooling water inlet of the Thermolator. This valve is required when the purge valve option is installed.

NOTE: For Isolated circuit units, Install vent line from top of tank. (refer to diagram “How It Works: Isolated Circuit”, Section 2)

The Thermolator process inlets and outlets must be connected to the plumbing that will circulate the temperature-controlled water or fluid through the process. Cooling water inlets and outlets are connected to the cooling water supply.

- 1 Remove the shipping pipe plug from the** female connections on the back of the Thermolator.
- 2 Install pipe to the rear of the Thermolator.** Use male 1¹/₄-inch NPT piping for process connections and male 3/4 inch NPT piping for cooling water connections. Pipe and pipe threads must be clean and new. Clean threads with solvent, removing all oil, grease and dirt. Allow the threads to dry before proceeding. Note: if installing pipe for Isolated Circuit install vent port.
- 3 Coat the pipe threads with thread sealant.** Follow the sealant manufacturer’s directions.
- 4 Connect the male pipe to the appropriate** female connection on the back of the unit. Start by hand until the threads engage, then use a pipe wrench to tighten the connection only enough to prevent leaks. Do not over-tighten!
- 5 If using the mold purge option** connect process and cooling water inlets and outlets, as well as a supply of non-lubricated compressed air.

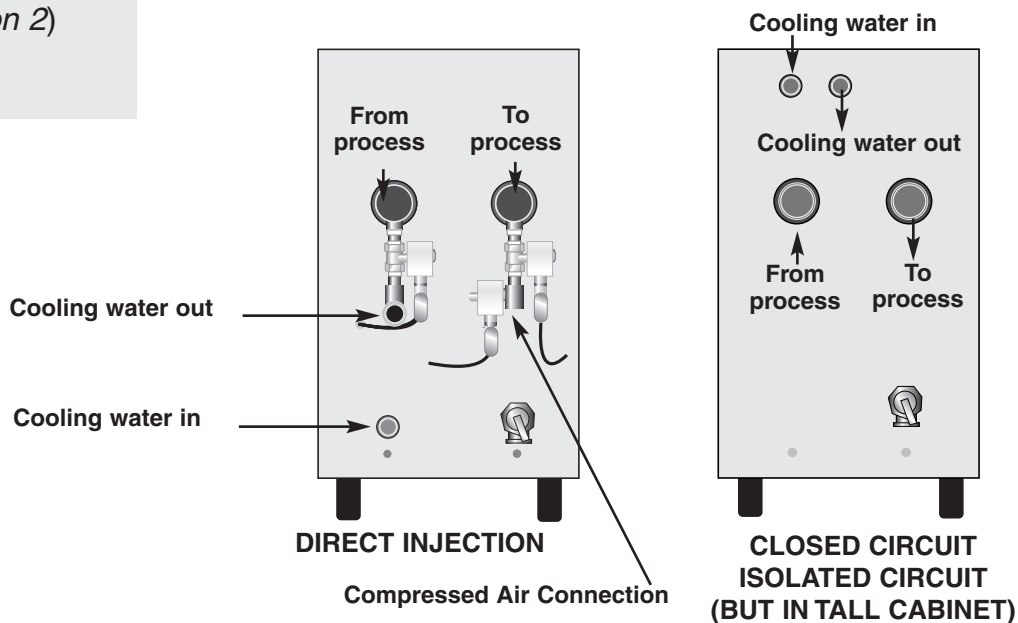



WARNING: Electrical shock hazard

This equipment is powered by three-phase main voltage. Always disconnect and lock out the main power source before performing any work involving electrical connections. All wiring, disconnects and fusing should conform to your region's electrical codes and should be installed only by qualified personnel.

CONNECTING THE MAIN POWER SUPPLY

Before beginning, note the electrical specifications on the nameplate mounted to the side of the unit. The electrical hookup must match these specifications with +/- 10% maximum voltage variance. An improper power supply could damage the unit as well as seriously injure an operator.

The electrical hookup also should run through a fused disconnect sized for the nameplate amperage and conforming to Article 250 of the National Electrical Code.

IMPORTANT: Always refer to the wiring diagrams that came with your temperature control unit before making electrical connections. The diagrams show the most accurate electrical component information.

- 1 Open the unit's electrical enclosure.**
- 2 Insert the main power wire through the knockout hole in the right side of the enclosure.**
- 3 Secure the power wire with a rubber compression fitting or strain relief.**
- 4 Connect the power wires to the terminals.**
Connect the three hot wires to L1, L2, and L3 on the terminal block.

- 5 Connect the ground wire to the copper grounding mount.** If you have installed a disconnect device, follow the manufacturer's wiring instructions.

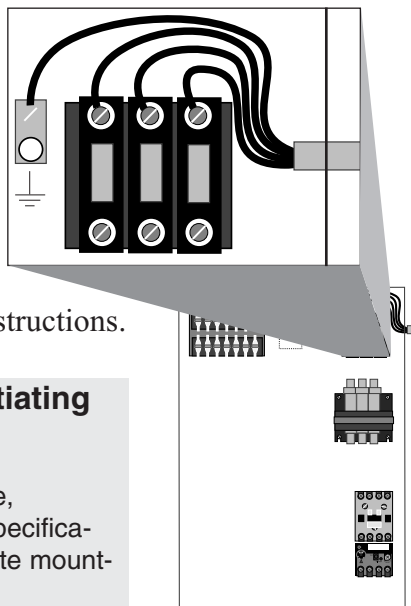

IMPORTANT! Before initiating power to the unit:

- Check the system for leaks.
- Verify that the voltage, phase, frequency, amperage, the specifications stated on the nameplate mounted on the side of the unit.
- Verify that resistance to ground on each phase is at least 1 meg ohm.

TESTING THE INSTALLATION TW PLUS CONTROL

NOTE: If the rotation is incorrect, stop the test and disconnect power to the unit. Open the electrical enclosure and switch any two of the three power source wires on the terminal block. Return to Step 2 and check rotation again.



WARNING: Only qualified personnel should perform this procedure.

Parts of this test requires opening the unit while it is energized. Only qualified personnel who have been trained in the use of electrical testing devices and in avoiding the safety hazards involved in safely troubleshooting this type of equipment should perform this test procedure.

- 1 Turn on the cooling water supply and check for leaks.** If any leaks appear, stop the test and fix the problem before continuing. The cooling water must be at least 25 PSI or the unit will not function. PAL will display if low water pressure is present after “ON” is pressed.
- 2 Apply power to the unit.**
- 3 Check the rotation of the pump.**
Remove the top access panel and the pump motor drip cover. Press and hold the ON/OFF button until the pump starts. Press and hold the ON/OFF button; verify that the pump rotation matches the direction indicated on the rotation sticker (clockwise-looking from drip cover end) on top of the pump.
- 4 Replace the drip cover and top access panel.**
- 5 Press and hold the ON/OFF button  until the vent cycle starts.** If everything is working correctly:
 - ◆ The ON Led button lights.
 - ◆ The unit initiates a venting sequence (To adjust, See *TW Plus Control Vent Timer Adjustment, Section 5.*) Cooling and venting valves are active for the first half of the sequence. The pump is active for the final half of the sequence. Indicator lights energize when the device is active.
 - ◆ Normal operation begins. The heater turns on if the actual temperature is below setpoint. The cooling valve opens if the actual temperature is above setpoint.

The test is over. If testing proceeded normally follow the remaining Installation steps for the TW Plus Control. *Otherwise refer to Troubleshooting, Section 6 and Maintenance, Section 5.*



WARNING: Only qualified personnel should perform this procedure.

Parts of this test requires opening the unit while it is energized. Only qualified personnel who have been trained in the use of electrical testing devices and in avoiding the safety hazards involved in safely troubleshooting this type of equipment should perform this test procedure.

TESTING THE INSTALLATION TW-1, TW-2 CONTROLS

- 1 Turn on the cooling water supply and check** for leaks. If any leaks appear, stop the test and fix the problem before continuing. The cooling water must be at least 25 PSI or the unit will not function. The LOW WATER PRESSURE light will come on when power is applied and RUN pressed. The light goes off when the pressure is adequate.
- 2 Apply power to the unit.**
 - ◆ Indicator lights on the control panel blink green, then red, to test operation of the LEDs.
 - ◆ Setpoint and actual windows display 888 for three seconds, followed by the software version. The windows then display the factory default setpoint of 100°F and the actual temperature.
- 3 Check the rotation of the pump.**

Remove the top access panel and the pump motor drip cover. Press and release the RUN button until the pump starts. Quickly press Pump Stop button; verify that the pump rotation matches the direction indicated on the rotation sticker on top of the pump.
- 4 Replace the drip cover and top access panel.**
- 5 Press and release the RUN button to start the unit.**

If everything is working correctly:

 - ◆ The Run/Stop light turns green.
 - ◆ The unit initiates a venting sequence, (*See TW1, TW2 Control Vent Timer Adjustment, section 5*). Cooling and venting valves are active for the first half of the sequence. The pump is active for the final half of the sequence. Indicator lights energize when the device is active.
 - ◆ Normal operation begins. The heater turns on if the actual temperature is below setpoint. The cooling valve opens if the actual temperature is above setpoint.

The test is over. If testing proceeded normally follow the remaining Installation steps for the TW-1, TW-2 Controls. *Otherwise refer to Troubleshooting, Section 6 and Maintenance, Section 5.*

NOTE: If the rotation is incorrect, stop the test and disconnect power to the unit. Open the electrical enclosure and switch any two of the three power source wires on the terminal block. Return to Step 2 and check rotation again.

TW PLUS CONTROL INITIAL SETUP

Menus on the Controller:

The controller has information available in 5 areas. Four of them are user accessible. These are: the Main Menu, the Setpoint Menu, the Configuration menu and the Alarm Page. (See *Troubleshooting, Section 6*) The service page also has additional parameters that are accessible in cases of need (See *Appendix C-1*).

Display of Control information:

The controller relays information via three modes.

1. The status lights indicate the state of the machine and its control components. In the thermolator these are Pump, Heater and Cooling valve.
2. The digital indication of the process in temperatures and times.
3. The alpha abbreviation of the process parameters to isolate the variables and the alarms from each other.

Main Menu

The main menu is the normal operating page. The controller always defaults to this page after a certain amount of inactivity (buttons being pushed). The first screen is the process variable. This is a user selectable parameter and could be the to process, from process or an average temperature or remote. The rest of the variables are accessed in a circular queue using only the up and down arrow keys.

The parameters include:

Process Variable- in the units selected on the Configuration page. This parameter has its decimal fixed to whole numbers only.





Machine State - For the thermolator this is ON/OFF/Vent/Purge (Pur).

The To Process temperature - in units selected as above.

The From Process temperature - in units selected above.

There is one additional temperature indicator available for the thermolator and must be purchased separately. If installed it will indicate only the temperature of the media to which the remote sensor is exposed. These temperature displays are also shown as whole numbers.

The Temperature units parameter allows selection of the displayed temperature units. The available selection is either degrees Celsius or Fahrenheit. °C or °F depicts this.

- 1** Press the setpoint/function key until the default configuration page Uni is displayed. 
- 2** Press setpoint/function key again to show °C or °F. 
- 3** Toggle between the up/down to select your desired units. 
- 4** Press setpoint/function key to accept the units. 
- 5** Wait for time out to verify the proper units of temperature are displayed.

TW PLUS CONTROL CHANGING TEMPERATURE UNITS

TW-1, TW-2 CONTROL INITIAL SETUP

NOTE: All dip switch illustrations in this manual show switches 7 and 8 set to ON. If you have an Isolated Circuit model, these switches should be set to OFF. Do not change the factory settings of these dip switches.



WARNING: Electric shock hazard

This equipment is powered by high voltage. Always disconnect and lock out the main power source before opening the unit or the electrical enclosure to modify factory settings. Failure to disconnect and lock out the main power source can result in severe personal injury.

The factory-set parameters and operating modes will satisfy most applications. But you can change some settings and enable or disable features as needed. *See Maintenance Section 5, list factory level.*

You can modify the parameters for high and low process temperature deviation warnings from the control panel or enable SPI communications. *See Setting Setpoint Deviation Parameters, Section 3.*

Dip switches on the TW-1 and TW-2 motherboard inside the electrical enclosure allow you to:

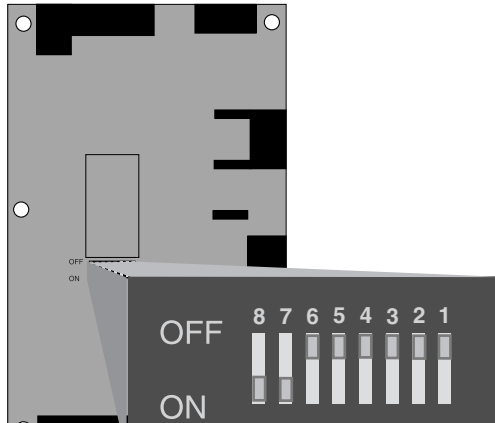

Dipswitch Configuration

No.	OFF	ON
1	Display units in °F	Display units °C
2	Auto Tune disabled	Auto Tune enabled
3	Passcode protect	Password reset/modify
4 *	Auto Start disabled	Auto Start enabled
5 *	Control point protect	Control point source select
6	Test Mode disabled	Test mode enabled
7 †	Controller type selection	Controller type selection
8 †	Controller type selection	Controller type selection

* Available only on TW-2 models.

† Switches 7 and 8 must be ON for Direct Injection and Closed Circuit models. Switches 7 and 8 must be OFF for Isolated Circuit models. Do not change these settings.

To change the dip switch settings, see the appropriate topic on the following pages.



WARNING: Electric shock hazard

This equipment is powered by high voltage. Always disconnect and lock out the main power source before opening the unit or the electrical enclosure to modify factory settings. Failure to disconnect and lock out the main power source can result in severe personal injury.

TW-1, TW-2 CONTROL CHANGING TEMPERATURE UNITS

The temperature units are factory-set as degrees Celsius or degrees Fahrenheit, as specified when the unit was ordered.

When the Thermolator is on, the indicator lights to the right of the Actual temperature display on the control panel will show which temperature unit has been set.

NOTE: All dip switch illustrations in this manual show switches 7 and 8 set to ON. If you have an Isolated Circuit model, these switches should be set to OFF.

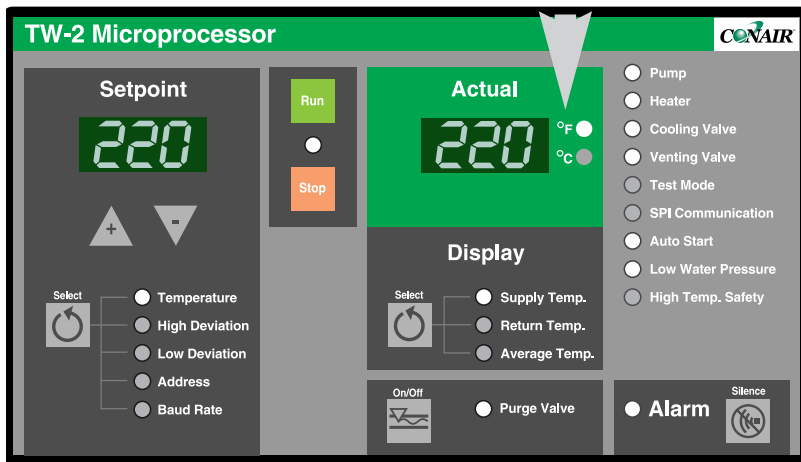

To change this setting, move Dip Switch 1 on the control circuit board.

1 Disconnect and lock out main power to the Thermolator.

2 Open the electrical enclosure.

3 Change Dip Switch 1 to:

OFF for °F

ON for °C

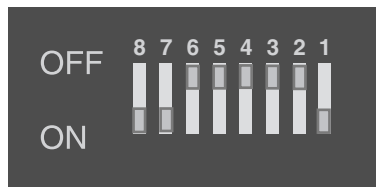
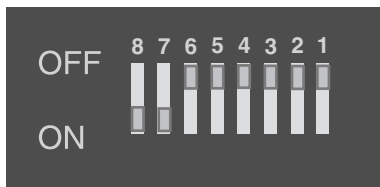

4 Close the electrical enclosure and restore main power to begin operating.

TW-1, TW-2 CONTROL ENABLING AND DISABLING PASSCODE PROTECTION

NOTE: All dip switch illustrations in this manual show switches 7 and 8 set to ON. If you have an Isolated Circuit model, these switches should be set to OFF.



WARNING: Electric shock hazard

This equipment is powered by high voltage. Always disconnect and lock out the main power source before opening the unit or the electrical enclosure to modify factory settings. Failure to disconnect and lock out the main power source can result in severe personal injury.

The TW-1 and TW-2 controls provide the ability to protect system parameters from unauthorized changes during normal operating mode. When system passcode protection is enabled, the following parameters cannot be changed unless you enter the correct passcode:

- The Process Setpoint
- High Deviation Alarm Setpoint
- Low Deviation Alarm Setpoint
- Baud Rate selection for serial communications
- Address selection for serial communications

When the unit is turned on for the first time, passcode protection is disabled. To enable passcode protection:

1 Disconnect and lock out main power to the unit.

2 Open the electrical enclosure.

3 Set dip switch 3 to ON and switches 5 and 6 to OFF.

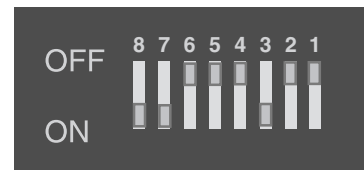

4 Close the electrical enclosure and restore power to the unit.

5 Press any button when the control displays “Pas rSt” (Passcode Reset). The control will display the last passcode used.

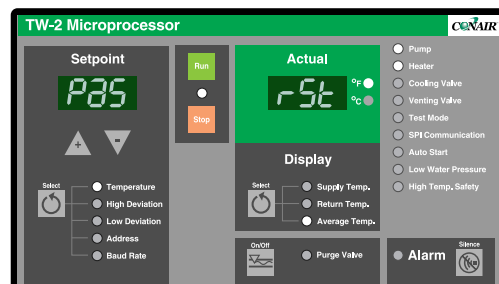

6 Select a new passcode using the ▲ and ▼ setpoint adjustment buttons. Stop pressing the setpoint buttons when the passcode you want appears in the setpoint display window. Selecting “OFF” as the passcode will disable the passcode feature.

Continued

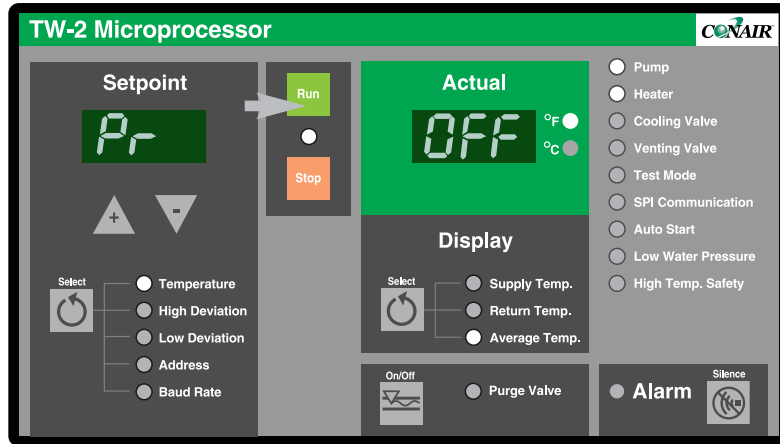

TW-1, TW-2 CONTROL ENABLING AND DISABLING PASSCODE PROTECTION CONTINUED

- 7** Press the **RUN** button to save the passcode.
 - ◆ The control will display “Pr OFF” to prompt you to remove power to the unit.

IMPORTANT: If RUN is not pressed, the new passcode will not be saved.

- 8** Turn off power to the unit. Disconnect and lock out the main power supply.

- 9** Open the electrical enclosure.

- 10** Set dip switch 3 to OFF.

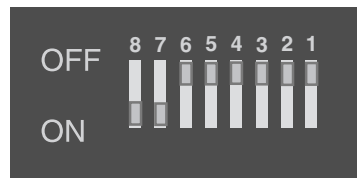

- 11** Close the electrical enclosure and restore power to the unit. A passcode now is required to change system parameters.

Disabling Passcode Protection

To disable passcode protection and allow universal access to system parameters:

- 1** Follow Steps 1 through 5 in the previous section on enabling passcode protection.

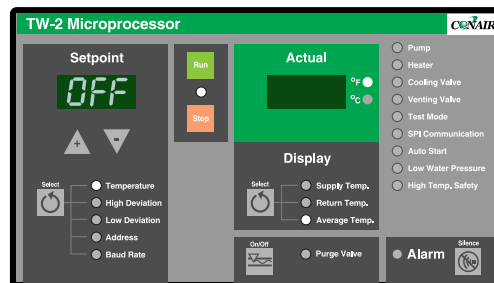

- 2** Hold down the ▼ setpoint adjustment button to select “OFF” as the new passcode.

- 3** Follow steps 7 through 11, above.

TW-2 CONTROL SELECTING THE TEMPERATURE CONTROL POINT



WARNING: Electric shock hazard

This equipment is powered by high voltage. Always disconnect and lock out the main power source before opening the unit or the electrical enclosure to modify factory settings. Failure to disconnect and lock out the main power source can result in severe personal injury.

NOTE: All dip switch illustrations in this manual show switches 7 and 8 set to ON. If you have an Isolated Circuit model, these switches should be set to OFF.

TW-1 controls the process temperature based upon the average of the temperatures recorded at the supply (to process) and return (from process) thermocouples.

TW-2 allows you to select how the unit will measure and control the process temperature. The control point can be selected as the supply, the return or the average of the the two temperatures.

To select the control point source on TW-2 models:

- 1 Disconnect and lockout power to the unit.**
- 2 Open the electrical enclosure.**
- 3 Set dip switches 3 and 6 to the OFF position.**
- 4 Set dip switch 5 to the ON position.**
- 5 Close the electrical enclosure and restore power to the unit.**
- 6 Press any button when the control displays “Cnt Pt”. The controller displays “Sel CnP” and flashes the LED for the current control point.**

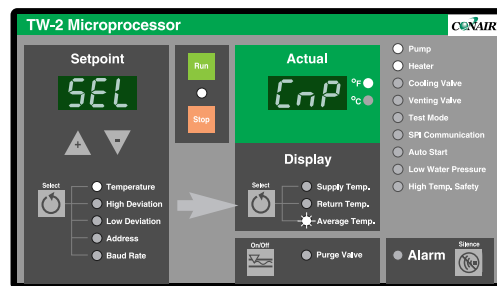
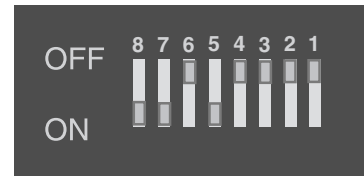

- 7 Select a new control point using the Display button. Stop pressing the select button until the indicator light next to the control point you want illuminates.**

Continued

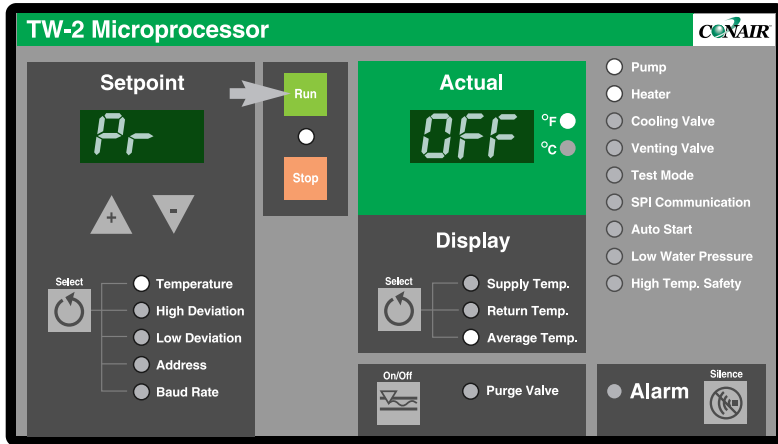

TW-2 CONTROL SELECTING THE TEMPERATURE CONTROL POINT CONTINUED

- 8** Press the **RUN** button to save the control point.
- ◆ The control will display “Pr OFF” to prompt you to remove power to the unit.

IMPORTANT: If RUN is not pressed, the new control point source will not be saved.

- 9** Turn off power to the unit.
Disconnect and lock out the main power supply.

- 10** Open the electrical enclosure.

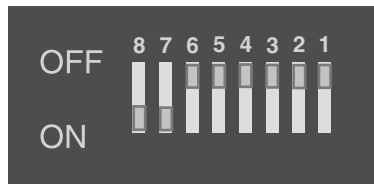

- 11** Set dip switch 5 to OFF.

- 12** Close the electrical enclosure and restore power to the unit. The TW-2 will now control the process temperature based on actual temperatures recorded at the new control point source.







TW PLUS CONTROL SELECTING THE TEMPERATURE CONTROL POINT



WARNING: Electric shock hazard

This equipment is powered by high voltage. Always disconnect and lock out the main power source before opening the unit or the electrical enclosure to modify factory settings. Failure to disconnect and lock out the main power source can result in severe personal injury.

TW Plus allows you to select how the unit will measure and control the process temperature. The control point can be selected as the supply, the return or the average of the the two temperatures. An additional temp sensor can be wired to sense a remote temperature.

- 1** Press and hold the enter key  until Uni is displayed.
- 2** Press the down arrow key  until PUS is displayed.
- 3** Press the enter key  to display the active control point.

- 4** Press the up/down keys  simultaneously to change control point.
- 5** Press the enter key  to accept the change and write control point to memory.
- 6** Wait for time out of unit to return to normal display.

Note: Moving control point will effect the controllability. Some sensor locations may not be coupled closely enough to the Thermolators fluid to allow proper control. *See TW Plus Control Performing Tune, Section 4.*

TW-1, TW-2 CONTROL ENTERING TEMPERATURE DEVIATION ALARM PARAMETERS

You can establish a normal operating range around the process temperature setpoint using the high and low deviation parameters. If the process temperature exceeds the high deviation limit, or falls below the low deviation limit for longer than the set delay time, the Thermolator alerts you to the unacceptable temperature variation with an alarm light, and optional audible or strobe.

These temperature deviation limits will adjust automatically relative to the process temperature setpoint.

The factory default setting for both the high and low deviation parameters is 25°F. These parameters are adjustable to establish a narrower or wider acceptable temperature band for normal operation.

To change the temperature deviation settings:

- 1 Press the Setpoint Select** button to select the deviation parameter you want to change.
- 2 Use the ▲ and ▼ setpoint** buttons to enter the deviation temperature. The setting is stored in memory even when the power is turned off. The recommended setting is $\pm 2-10^{\circ}\text{F}$.

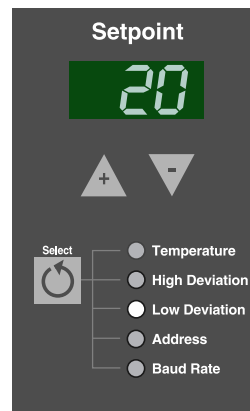

NOTE: If you enabled passcode protection, you must enter the passcode to change this parameter. To enter the passcode:

Hold down the Setpoint Select button for 5 seconds. When the control displays “1 PaS”, use the setpoint adjustment buttons to enter the passcode. Press the Setpoint Select button again. If the correct passcode was entered the controller will display ACC PAS for 3 seconds. If the passcode was incorrect, the controller will display rEJ PAS (rejected passcode).

Access to system parameters remain until power is cycled or the RUN or STOP button is pressed.

TW-2 CONTROL INSTALLING THE AUTO START FEATURE



WARNING: Electric shock hazard

This equipment is powered by high voltage. Always disconnect and lock out the main power source before opening the unit or the electrical enclosure to modify factory settings. Failure to disconnect and lock out the main power source can result in severe personal injury.

If you have a TW-2 model, you can automatically start and stop the Thermolator from a remote switching or timing device that has power contacts rated 110VAC, such as the process machine control.

Wiring the device to the Thermolator is accomplished through a dry contact to the appropriate terminals on the motherboard. After wiring the device to the unit, Auto Start must be enabled by configuring a dip switch on the motherboard.

IMPORTANT: Always refer to the wiring diagrams that came with your temperature control unit before making electrical connections. The diagrams show the most accurate electrical component information.

- 1 Disconnect and lockout power to the unit.**
- 2 Open the electrical enclosure.**
- 3 Punch a small hole in the left side of the electrical enclosure. The hole must be large enough to accommodate conduit for the power contact wires from your switching or timing device.**
- 4 Insert the two power leads from the device through the conduit into the electrical enclosure.**

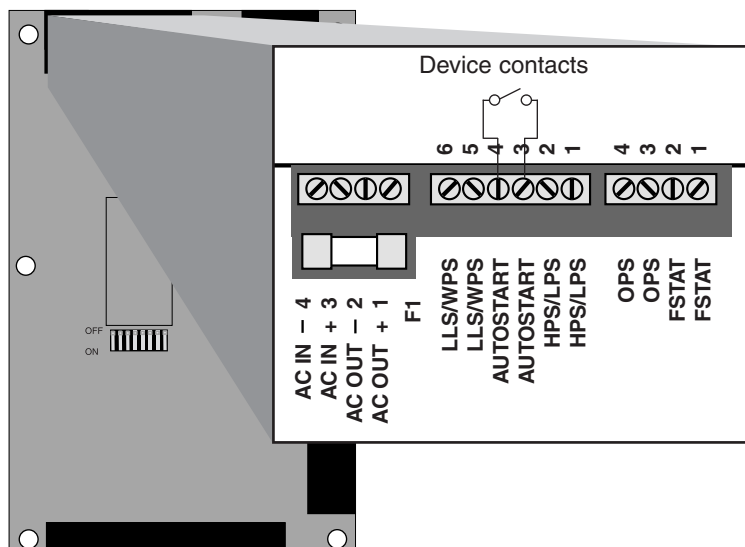

- 5 Connect the 110VAC device contact wires to the Auto Start terminals. Make sure terminals are screwed tight.**

6 Set dip switch 4 to the ON position.

7 Close the electrical enclosure and restore power to the unit.

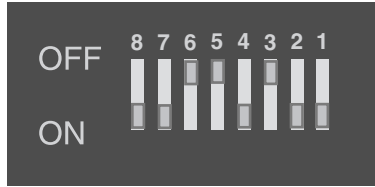

TW-2 CONTROL INSTALLING THE AUTO START FEATURE

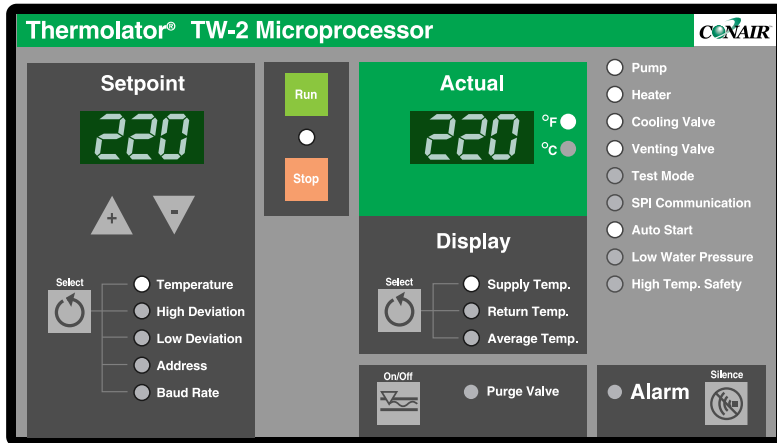

NOTE: All dip switch illustrations in this manual show switches 7 and 8 set to ON. If you have an Isolated Circuit model, these switches should be set to OFF.

When Auto Start is enabled:

- ◆ The Auto Start indicator light flashes to indicate that the Thermolator can start at any time. The Thermolator will start whenever the remote switching or timing device sends a signal to start processing.
- ◆ The Auto Start indicator light is on whenever the Thermolator is under the control of the remote device.

To disable Auto Start:

Repeat steps 1, 2 and 7, setting dip switch 4 to the OFF position instead of the ON position.

POSITIONING THE TW-2 CONTROL PANEL



CAUTION: Improper handling of the control panel can damage the unit.

DO NOT mount the detached TW-2 control panel to a hot surface.

The TW-2 control panel can be mounted up to 50 feet from the unit, using a remote control cable and the magnets on the back of the panel.

Do not stretch the cable. The cable is available in 30 and 50 foot lengths so that you can order the appropriate cable for your installation.

To detach the TW-2 control panel:

Grasp the black control panel handles and pull upward.

Use the magnetic back to mount the control panel in the remote location. Connect the remote-mounted control to the unit with the cable provided.

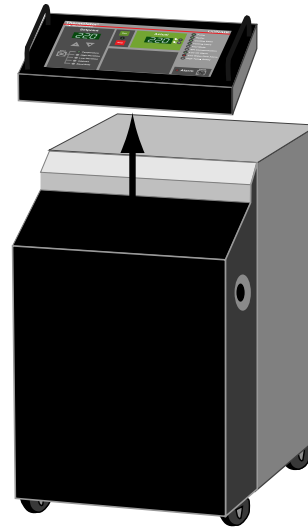

OPERATION

- *TW Plus Control Features*4-2
- *TW Plus Control Menu*4-3
- *TW-1 Control Features*4-4
- *TW-2 Control Features*4-5
- *Starting the TW*4-6
- *Stopping the TW*4-7
- *Starting the TW-1, TW-2*4-8
- *Stopping the TW-1, TW-2*4-9
- *Using the TW Plus Manual Purge Option*4-10
- *Using the TW-1 Manual Purge Option*4-11
- *Using the TW-2 Purge Feature* .4-12
- *TW Plus Control Performing an Auto Tune*4-13
- *TW-1, TW-2 Control Performing an Auto Tune*4-14
- *TW-1, TW-2 Control Entering Passcodes*4-16

TW PLUS CONTROL FEATURES

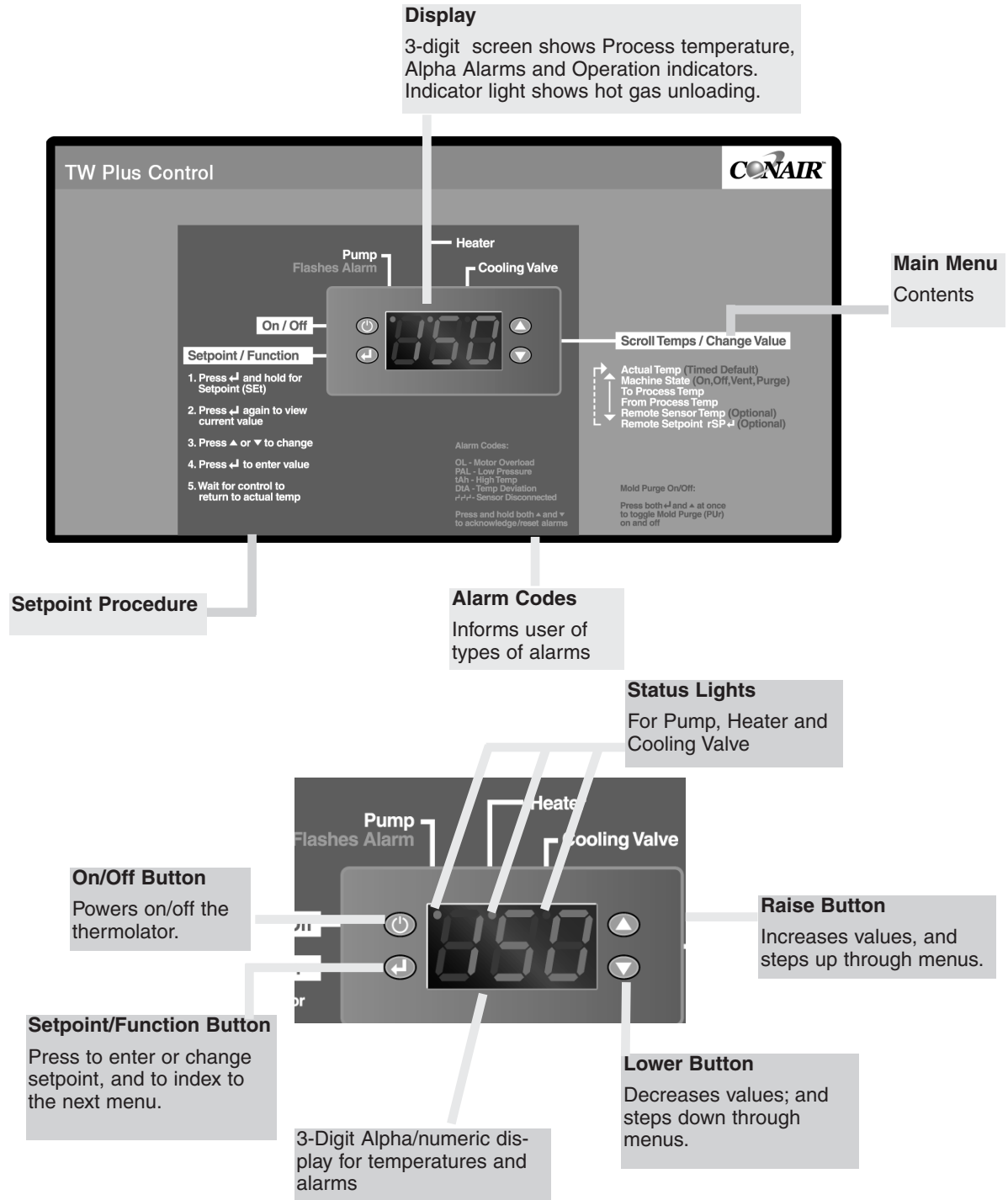

The TW Plus temperature controller uses a menu system to access different operating modes or change system parameters. Please see *the Appendix C-1* for default parameter settings and detailed information on each of these modes and parameters

TW PLUS CONTROL MENU

Parameter Menus

Uni	Temperature Units. Allows selection of the displayed temperature units.
PUS	Process Variable. Allows the operator to select the controlled temperature from the following: To Process, From Process and Average.
Pit	Tuning the Thermolator. The controller has three pre-configured tuning parameter sets, one of which should allow optimum temperature control.
dsp	Deviation Setpoint. The number of degrees away from setpoint beyond which the alarm is enabled.
ddt	Deviation Delay Time. The number of seconds after which the Dta alarm is activated.
ut1	Vent Time 1. Cooling Valve on.
ut2	Vent Time 2. Cooling valve with pump on.
AAt	Alarm Acknowledge timer. Sets the time that an alarm can be acknowledged and silenced without being satisfied.
t02	Software Version. This “read only” parameter depicts the version of software that has been downloaded into the controller.

Press and hold  for five seconds to access the menu item.

Press  to index through  the menus.

Press  to access parameter value under each menu item.

Press  to index menu  item.

Press  to save change and scroll to next parameter.

TW-1 CONTROL FEATURES

All normal operating functions can be controlled from the TW-1 control panel. If you have the optional manual mold purge, the control switch is located on the side of the Thermolator electrical enclosure.



Setpoint display

The Setpoint display shows the setpoints entered for fluid temperature, high and low temperature deviation alarms, the SPI baud rate, and the SPI address.

Setpoint and Actual value display windows also display some alarm codes and setup instructions.

Run/Stop

Press RUN button to start normal operation. Press STOP to stop the temperature control unit.

-  = Running (green)
-  = Stopped (red)
-  = Alarm (red, flashing)

Actual values display

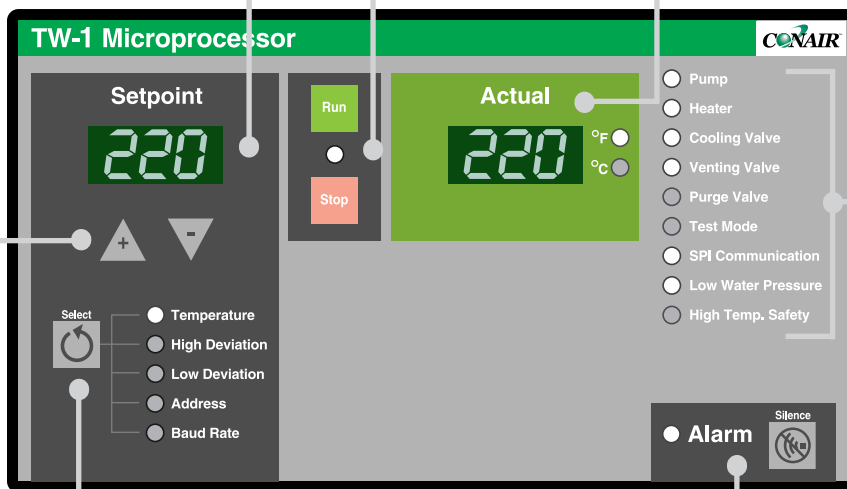

The green window displays the temperature at the middle of the mold. This temperature is calculated as an average of the temperatures of the supply water and return water.

The lights indicate whether the temperature is in degrees Fahrenheit or Celsius. See *Installation, section 3* for instructions on how to change the temperature units.





Status lights

The lights indicate the operating status of the listed components. Except in Test Mode, the lights indicate:

-  = Off or inactive
-  = On or active (green)
-  = Alarm condition (red)

Test Mode is used for testing displays, keys and input/output functions. When test mode is enabled, normal operation is disabled.

-  = Test Mode off
-  = Test Mode on (red); unit disabled

Setpoint Select button

Press repeatedly until the green light appears next to the parameter you want to program or view.

NOTE: Default settings for the deviation setpoints are:

High = setpoint + 25°F

Low = setpoint - 25°F

A warning alarm occurs (indicator light red) whenever the actual temperature is outside this setpoint range for more than the set delay. Recommended setting: ± 2-10°F.

Alarm

Press to acknowledge the alarm light and silence the optional audible alarm. The alarm light will flash until the cause of the alarm condition is fixed. See Troubleshooting for alarm descriptions and remedies.

Setpoint adjustment buttons

Press ▲ or ▼ to enter the process temperature setpoint, SPI parameters and passcodes.

Press ▲ to increase a value.

Press ▼ to decrease a value.

TIP: Press and hold the button for faster scrolling speed.

NOTE: Passcode protection prevents accidental or unauthorized changes to all operating parameters. If passcode protection has been enabled, you must enter the correct passcode to change the process temperature setpoint.

All normal operating functions can be controlled from the TW-2 control panel, including the optional mold purge.

TW-2 CONTROL FEATURES

Setpoint display
The Setpoint display shows the setpoints entered for fluid temperature, high and low temperature deviation alarms, the SPI baud rate, and the SPI address.
Setpoint and Actual value display windows also display some alarm codes and setup instructions.

Run/Stop
Press RUN button to start normal operation. Press STOP to stop the temperature control unit.
● = Running (green)
● = Stopped (red)
☠ = Alarm (red, flashing)

Actual values display
The green window displays the temperature at the middle of the mold. This temperature is calculated as an average of the temperatures of the supply water and return water.
The lights indicate whether the temperature is in degrees Fahrenheit or Celsius. See *Installation, section 3* for instructions on how to change the temperature units.

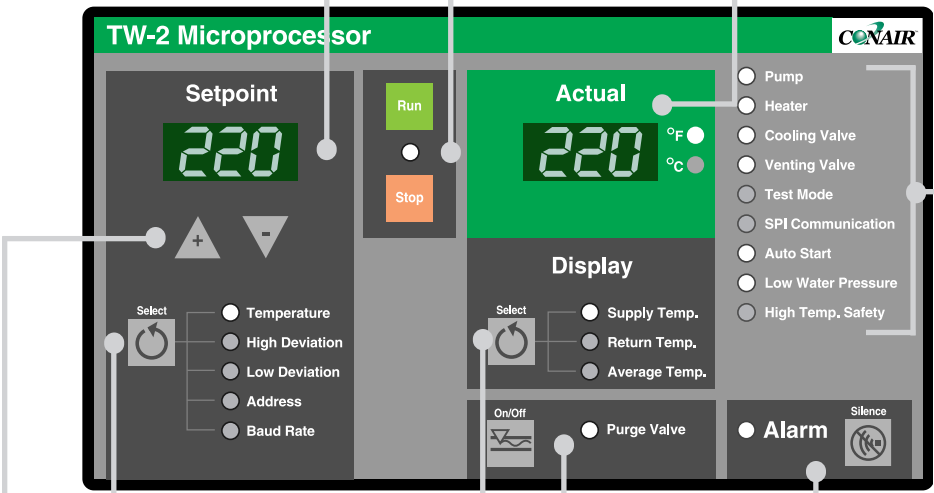

Status lights
The lights indicate the operating status of the listed components. Except in Test Mode and Auto Start, the lights indicate:
○ = Off or inactive
● = On or active (green)
● = Alarm condition (red)

Test Mode is used for testing displays, keys and input/output functions. When test mode is enabled, normal operation is disabled.
○ = Test Mode off
● = Test Mode on (red); unit disabled

Setpoint Select button
Press repeatedly until the green light appears next to the parameter you want to program or view.
NOTE: Default settings for the deviation setpoints are:
High = setpoint + 25°F
Low = setpoint - 25°F
A warning alarm occurs (indicator light red) whenever the actual temperature is outside this setpoint range for more than the set delay.
Recommended setting: ± 2-10°F.

Alarm
Press to acknowledge the alarm light and silence the optional audible alarm. The alarm light will flash until the cause of the alarm condition is fixed. See Troubleshooting for alarm descriptions and remedies.

Purge Valve
The light indicates the operating status of the purge valve. Except in Test Mode and Auto Start, the light indicates:
○ = Off or inactive
● = On or active

Setpoint adjustment buttons
Press ▲ or ▼ to enter the process temperature setpoint, SPI parameters and passcodes.
Press ▲ to increase a value.
Press ▼ to decrease a value.
TIP: Press and hold the button for faster scrolling speed.

Display Select button
Press repeatedly until the green light appears next to the temperature you want to view.

Auto Start allows you to start and stop the unit from a remote switching or timing device, such as the processing machine control. This feature can only be enabled by configuring a dip switch on the control motherboard.
○ = Disabled; Auto Start not available
☠ = Enabled (flashing green); unit can start any time
● = On and under control of the remote device

STARTING THE TW PLUS





Before starting the Thermolator, verify that the system has been installed correctly for your application. *See Section 3, Installation.*

1 Turn on the water supply to the Thermolator.

The supply pressure must be at least 25 psi. Check for leaks in the cooling water and process fluid lines before continuing.

2 Turn on main power to the Thermolator.

3 Set the temperature setpoint to 100°F. (If operating at 100°F or higher. If operating at a lower temperature, lower setpoint.)





Press and hold  till SEt displayed. Press  to display setpoint. Press  to increase or  to decrease the temperature setting. Press  to accept.



4 Press and hold START  until the vent cycle begins.

If everything is working correctly:

- ◆ The Cooling indicator lights and machine status is Unt.
- ◆ The unit initiates a variable venting sequence. The pump starts after the vent time 1 is over.
- ◆ Normal operation begins after vent 2 is over. The heater turns on if the actual temperature is below setpoint. The cooling valve is active if the actual temperature is above setpoint.

5 Set the setpoint to the desired temperature.

Press and hold  till SEt displayed. Press  to display setpoint. Press  to increase or  to decrease the temperature setting. Press  to accept.

If, after setting the setpoint to the desired temperature, the optional Fault light/ alarm turns on, press the  UP/Down buttons  simultaneously to silence the alarm. Then go to Troubleshooting, section 6 to correct problem.

STOPPING THE TW PLUS



WARNING: Electrical shock and hot surface hazards

Before attempting maintenance of any kind on the Thermolator, you must stop the unit; disconnect and lockout the main power supply; and allow the unit to cool to less than 100°F (38°C).



You must shut down the Thermolator whenever you:

- Change the water hookups.
- Shut down the process machine.
- Purge the process circuit of the water or fluid.
- Run the unit's diagnostic tests.
- Perform routine or preventative maintenance.
- See an alarm condition that requires troubleshooting.
- Relocate, ship or store the unit.

To shut down the unit for purging the process lines, diagnostic testing, routine maintenance or troubleshooting, press the ON/OFF button. Then refer to the appropriate topic or section in this User Guide for additional instructions.

To shut down the unit to change water hookups:

1 Cool Unit to Less than 100° F

2 Press ON/OFF

3 Shut off the cooling water supply, relieve any pressure in the unit (see Pressure gauges) by lifting the relief valve lever; then drain the unit of all fluid. Use the relief valve on the back of the unit.

4 Once the unit is cool, remove the water hookups.

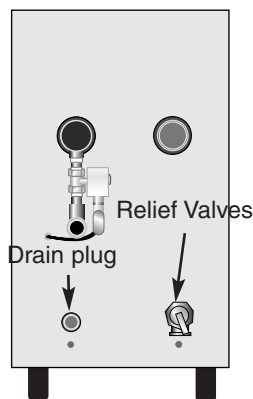

To shut down the unit for relocation or storage:

1 Press ON/OFF

2 Drain the unit of all fluid.

Drain the unit using the drain plug or relief valve. Tip unit back to drain water from pump volute.

3 Disconnect the power supply and all water feeds. In shipment or storage, the Thermolator can withstand an environment between -40°F (-40°C) and 120°F (65°C) with 95% relative humidity non-condensing.

STARTING THE TW-1, TW-2

IMPORTANT: If you are operating the Thermolator for the first time since installation, you should perform an Auto Tune after two hours of normal operation. You should perform the Auto Tune periodically to ensure that the control correctly calculates how much heat and cooling should be applied to maintain the process setpoint. See *Performing an Auto Tune, Section 4*

Before starting the Thermolator, verify that the system has been installed correctly for your application. See *Section 3, Installation*.

If Passcode Protection has been enabled, you must enter the correct passcode before you can change or enter any of the operating parameters, including the temperature setpoint.

1 Turn on the water supply to the Thermolator.
The supply must be at least 25 psi. Check for leaks in the cooling water and process fluid lines before continuing.

2 Turn on main power to the Thermolator.
The control initiates a brief self test.
◆ Indicator lights blink green, then red.
◆ Setpoint and actual windows will display **888** for three seconds, followed by the software version. The windows then display the factory default setpoint of 100° F and the actual temperature.

3 Enter the passcode, if necessary. Hold the Setpoint Select button for 5 seconds. When the control displays 1 PaS, use the setpoint adjustment buttons to enter the passcode. Press the Setpoint Select button again.

4 Enter the temperature setpoint. Press the Setpoint Select button until the green light appears next to Temperature. Press ▲ to increase or ▼ to decrease the temperature setting.

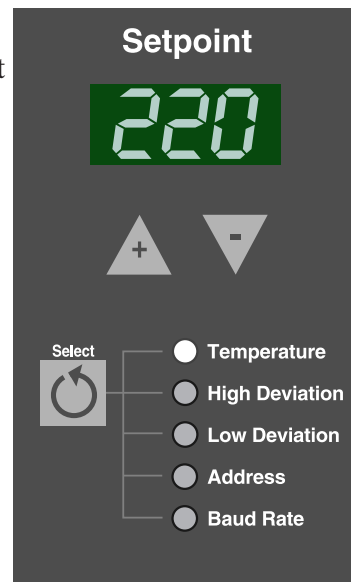

5 Press **Run to start normal operation.**
◆ The RUN/STOP light turns green.
◆ The unit initiates a 60-second venting sequence. Cooling and venting valves are active for 60 seconds. The pump is active for the final 30 seconds.
◆ Normal operation begins. The heater turns on when the actual temperature is below setpoint. The cooling valve turns on if the actual temperature is above the setpoint.

If the Alarm light turns on, press  to silence the optional audible alarm. See *Troubleshooting, Section 6*.



WARNING: Electrical shock and hot surface hazards

Before attempting maintenance of any kind on the Thermolator, you must stop the unit; disconnect and lockout the main power supply; and allow the unit to cool to less than 100°F (38°C).



STOPPING THE TW-1, TW-2

You must shut down the Thermolator whenever you:

- Change the water hookups.
- Shut down the process machine.
- Purge the process circuit of the water or fluid.
- Run the unit's diagnostic tests.
- Perform routine or preventative maintenance.
- See an alarm condition that requires troubleshooting.
- Relocate, ship or store the unit.

To shut down the unit for purging the process lines, diagnostic testing, routine maintenance or troubleshooting, press the Stop button. Then refer to the appropriate topic or section in this User Guide.

To shut down the unit to change water hookups:

- 1 Press Stop, shut off cool water in and out and drain the unit** of all water or fluid.
Drain the unit using the relief valve on the back of the unit.

- 2 Once the unit is cool, remove** the water hookups.



To shut down the unit for relocation or storage:

- 1 Press Stop, shut off cool water in and out and drain the unit of all fluid.**
Drain the unit using the two drain plugs.

- 2 Disconnect the power supply cord if necessary** and all water feeds.

- 3 Position the control panel to rest flush with the** unit. (TW2 only)

In shipment or storage, the Thermolator can withstand an environment between -40°F (-40°C) and 120°F (65°C) with 95% relative humidity non-condensing.

USING THE TW PLUS MOLD PURGE OPTION

The TW Plus Thermolator can be ordered with a mold optional purge valves, which clears the process lines of fluid using compressed air. The valves are operated by a combination of buttons on the control panel

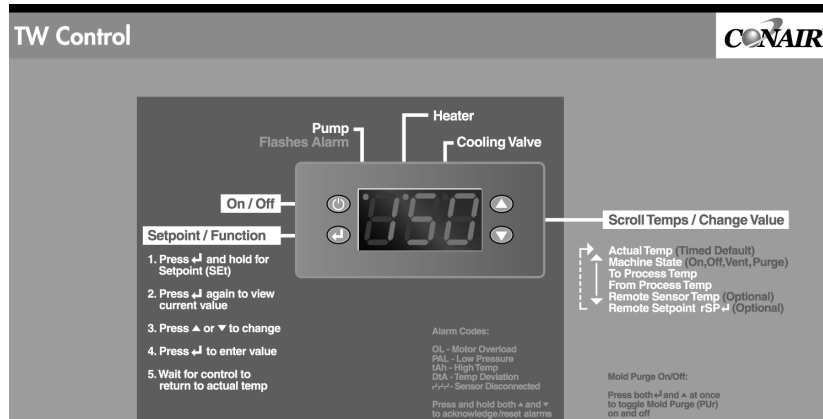

IMPORTANT: Before purging the process lines, be sure that the cooling water source feed is closed. If the feed is open and the air line has a higher pressure than the cooling water, air may be injected into the cooling water system. If the cooling water pressure is higher than the air line, cooling water may be injected into the air line.

1 Press **ON/OFF**  to stop the Thermolator.

2 Shut off the cooling water supply valve.

3 Press both   at once to toggle **Mold Purge (PUR)** to start purging.

- ◆ The Vent and Cool outputs are activated.
- ◆ The ON/OFF buttons are deactivated during the purge or when the cool delay off timer is active.

The time required to clear the process lines of fluid will vary according to the length of the process piping and the size of the tooling.

4 Press both   again to stop purging.

- ◆ The Vent (CC) and cool solenoids remain energized for 5 seconds after the Purge is terminated to remove the system pressure.

The TW-1 direct injection and closed circuit models can be ordered with optional mold purge, which clears the process lines of fluid using compressed air. The purge is operated by a manual switch on the left side of the unit.

USING THE TW-1 MOLD PURGE OPTION

IMPORTANT: Before purging the process lines, be sure that the cooling water source feed is closed. If the feed is open and the air line has a higher pressure than the cooling water, air may be injected into the cooling water system. If the cooling water pressure is higher than the air line, cooling water may be injected into the air line.

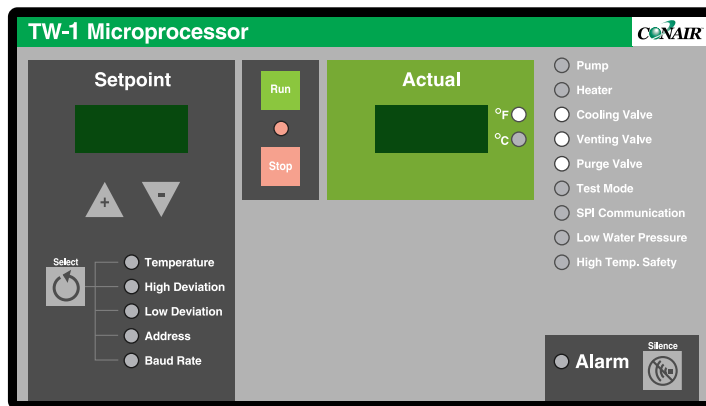

- 1 Press **Stop** to shut down the Thermolator.**
 - ◆ The RUN/STOP LED turns red.
- 2 Shut off the cooling water supply to the unit.**
- 3 Turn the manual purge switch to the “ON” position to start purging.**
 - ◆ The Purge Valve LED lights.
 - ◆ The Vent and Cool outputs are activated.
 - ◆ The STOP and RUN buttons are deactivated during the purge or when the cool delay off timer is active.

The time required to clear the process lines of fluid will vary according to the length of the process piping and the size of the tooling.

- 4 Turn the purge switch to the “OFF” position to stop purging.**
 - ◆ The Vent and Cool solenoids remain energized for 5 seconds after the purge is terminated.

NOTE: The purge operation will terminate immediately if the unit detects a blown fuse in the Vent or Cool output. The unit will alarm and shut down.



See Troubleshooting, Section 6, for instructions on how to clear the alarm and fix the problem.

USING THE TW-2 MOLD PURGE OPTION

The TW-2 direct injection and closed circuit models can be ordered with optional mold purge, which clears the process lines of fluid using compressed air. The purge is operated by a button on the control panel.

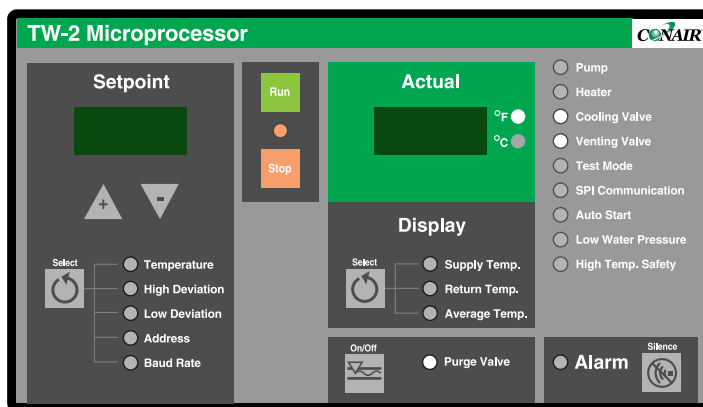
IMPORTANT: Before purging the process lines, be sure that the cooling water source feed is closed. If the feed is open and the air line has a higher pressure than the cooling water, air may be injected into the cooling water system. If the cooling water pressure is higher than the air line, cooling water may be injected into the air line.



- 1 Press  to shut down the Thermolator.**
 - ◆ The RUN/STOP light turns red.
- 2 Shut off the cooling water supply to the unit.**
- 3 Press  to open the valve and start purging.**
 - ◆ The Purge Valve LED lights.
 - ◆ The Vent and Cool outputs are activated.
 - ◆ The STOP and RUN buttons are deactivated during the purge or when the cool delay off timer is active.

The time required to clear the process lines of fluid will vary according to the length of the process piping and the size of the tooling.
- 4 Press  to close the valve and stop purging.**
 - ◆ The Vent and Cool solenoids remain energized for 5 seconds after the purge is terminated.

NOTE: The purge operation will terminate immediately if the unit detects a blown fuse in the Vent or Cool output. The unit will alarm and shut down.

See Troubleshooting, Section 6 for instructions on how to clear the alarm and fix the problem.

TW PLUS CONTROL PERFORMING A TUNE

NOTE: Before performing a tune, verify system flow (cooling and process) is adequate for your application.

The controller has three pre-configured tuning parameter sets, one of which should allow optimum temperature control. Following is a description of each of the choices available to an operator:

Slow Responding system:

Select the slow setting “SLo” for large systems. More than 1,700 pounds (200 gallons) of water and more than 14,000 lbs of steel might be considered a large system. This setting has the smallest proportional band (2°F), which allows larger changes in the control output when the process temperature is far from setpoint. This should reduce cycling around the setpoint.

Normal Responding System:

Normal “nor” is the factory default tuning setting, as it will cover the majority of applications. This setting is appropriate for systems with 250 to 1,700 pounds (130-200 gallons) of water and 1,000 to 14,000 pounds of steel. The default value for the normal proportional band is 10°F.





Fast Responding System:

Select the fast setting “FSt” for small systems. Less than 80 pounds of water (10 gallons) and 1,000 pounds of steel might be considered a small system. This setting has the largest proportional band (15°F), which allows a fast response to small deviations between the process variable and setpoint. This system is typical for small thermolators with small molds or other process machinery. If improperly set up, the configuration might cause oscillation around the setpoint temperature.

NOTE: Normal parameter is the factory default setting.

Setup Menu

To access the Setup Menu,

- 1 Press and hold the “setpoint/function” key for approximately five seconds, until Uni displays** 
- 2 Toggle the Up/Down keys until “Pit” is displayed.** Press the “setpoint/function” key once to see the current tuning setting. 

- 3 Toggle the Up/Down arrow keys to the desired SLo, nor or FSt setting.** Press “setpoint/function” again to save this value. The selection flashes until saved and advances to the next parameter. If at any time no key is pressed for 10 seconds the control will return to “Home Page”, displaying the process variable. If the unit is in any alarm condition, you must clear it before you can adjust the tuning selector. 

TW-1, TW-2 CONTROL PERFORMING AN AUTO TUNE



WARNING: Electric shock hazard

This equipment is powered by high voltage. Always disconnect and lock out the main power source before opening the unit or the electrical enclosure to modify factory settings. Failure to disconnect and lock out the main power source can result in severe personal injury.

You should perform an Auto Tune after the first two hours of operation and whenever process variables change (changes in cooling water pressure, piping or molds; large ambient swings; new setpoint temperature) to ensure that the control continues to obtain good approximations of the PID constants used to compensate for the thermal lag of the system.

To ensure a successful Auto Tune, verify that:

- The Auto Tune feature has been enabled.** Auto Tune is enabled or disabled via dip switch 2 on the motherboard.
- The process value is stable.** A fluctuating process value will fool the software into making inaccurate tuning decisions. The software waits 5 minutes for the process value to stabilize before it starts the Auto Tune process. If the process value still fluctuates after 5 minutes, the Auto Tune terminates and the control displays the “At ti” error.
- The control is in STOP mode and the process value is in ambient temperature.** This allows the software to obtain good approximations of process parameters, which are critical for performing an accurate tune. If this requirement is not met, then a good tune cannot be guaranteed.
- The setpoint/process deviation is at least 25° F.** If the absolute value of setpoint - process temperature is not greater than or equal to 25°F, the Auto Tune will terminate. The control will display an “At dEV” error.

1 Press  to shut down the Thermolator.

2 Disconnect and lock out main power to the unit.

3 **Enable Auto Tune.**
Open the electrical enclosure. Set dip switch 2 to ON. Close the electrical enclosure and restore power to the unit.

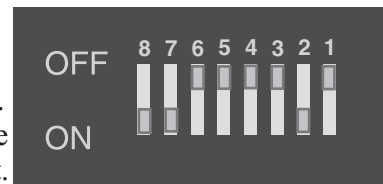

4 Restore power to the unit.

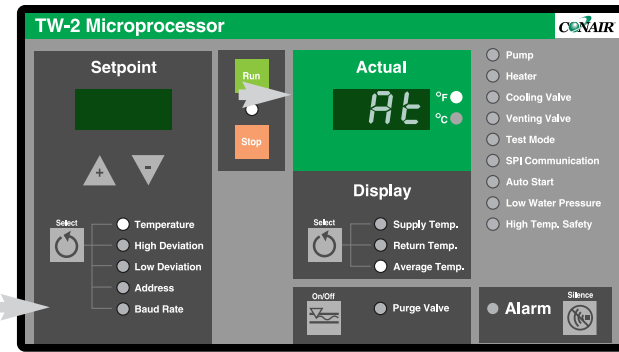

TW-1, TW-2 CONTROL PERFORMING AN AUTO TUNE







- 5** Set the setpoint to desired value.
- 6** Press **Run** and  (the Setpoint Select button) simultaneously to begin the Auto Tune. The pump energizes, the Actual display flashes “At” and the current process temperature to indicate that an Auto Tune is underway.

NOTE: Dipswitch #2 can remain on during normal operation

If Auto Tune is successful, the controller automatically starts controlling using the new PID parameters.

If you press the STOP button or a fault occurs during the Auto Tune, the control enters stop mode and Auto Tuning immediately terminates. The Actual display stops flashing “At.” If a fault occurred, the control displays the appropriate error message.

- 7** Repeat steps 5 and 6 if attempt was unsuccessful or poor performance is still evident.
- 8** If Autotune is still unsuccessful; verify pump rotation, cooling and vent (cc only) are operating correctly and no restrictions in the cooling and process piping.

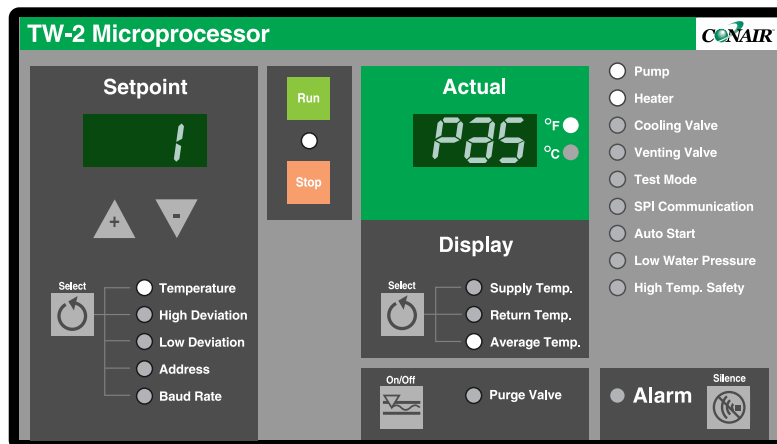

ERROR MESSAGE	ERROR DESCRIPTION
 	Insufficient setpoint/process deviation. If the absolute value of (setpoint - process value) is less than 25°F. The Auto Tune cannot be started until the temperature difference is at least 25°F.
 	Auto Tune timed out. Auto Tune will time out if a stable process value cannot be obtained 5 minutes into the tune, or if the tuning process takes longer than 30 minutes. If this error occurs, verify that you followed every requirement under “To ensure a successful Auto Tune” and perform a second tune.
 	Invalid PID constants were generated. The most likely causes of this error is a tune started inappropriately or an external element (i.e., loose thermocouple) that upset the process while tuning was in progress. Verify that you followed every requirement under “To ensure a successful Auto Tune” and perform a second tune.

TW-1, TW-2 CONTROL ENTERING PASSCODES



The TW-1 and TW-2 models have a security feature that prevents accidental or unauthorized changes to the setpoint temperature, high and low deviation limits, SPI address, and baud rate.

If passcode protection is enabled, you must enter the correct passcode to change these parameters. To enter the passcode:

- 1 Press and hold the Setpoint Select button**  for 5 seconds. The control will display 1 PaS to indicate a passcode is needed.
- 2 Press the Select ▲ button until the correct passcode appears in the display.**
- 3 Press**  **again to enter the passcode.**
If the passcode is correct, the control displays ACC PAS for 3 seconds. If the passcode is incorrect, the control displays rEJ PAS (rejected passcode) for 3 seconds.
- 4 Press Setpoint**  **to select the parameter you want to change.**

You have access to the system parameters until:

- The power is cycled off and on.
- The RUN or STOP button is pressed.
- The system times out on inactivity.

NOTE: Pressing the STOP or RUN key while you are entering a passcode will abort the passcode entry sequence.

MAINTENANCE

- **Maintenance Schedule5-2**
- **Accessing the Thermolator**
 - Enclosure5-3**
- **Checking Reservoir**
 - Fluid Levels5-4**
- **TW-1, TW-2 Control Performing**
 - System Tests5-5**
- **TW-1, TW-2 Control Key/Display Test .5-6**
- **TW-1, TW-2 Control Input Test5-7**
- **TW-1, TW-2 Control Output Test5-8**
- **TW-1, TW-2 Control Disabling or**
 - Enabling Output Monitors5-9**
- **TW-1, TW-2 Control Calibrating**
 - Temperature Sensors5-10**
- **TW-1, TW-2 Control Logging Operating**
 - Hours5-12**
- **TW-1, TW-2 Control Pulse Mode**
 - Description5-13**
- **TW-1, TW-2 Control Pulse**
 - Mode Setup5-14**
- **TW-1, TW-2 Control Pulse Mode**
 - Limits & Defaults5-14**
- **TW-1, TW-2 Control Deviation**
 - Alarm/Inhibition Delay5-15**
- **TW, TW-1, TW-2 Control Vent Timer**
 - Adjustment5-16**

PREVENTATIVE MAINTENANCE SCHEDULE FOR TW, TW-1 AND TW-2

NOTE: There is no Auto-tune for the TW Plus control.

Thermolator TW Series water temperature controllers are essentially maintenance-free. However, to maintain the best performance, we recommend the following maintenance schedule.

- **Whenever process variables change**

- Perform an Auto Tune.**

The Auto Tune ensures that the control continues to obtain good approximations of the PID constants used to compensate for the thermal lag of the system. You should perform an Auto Tune after the first two hours of operation and whenever the process changes, such as after a mold change; installation of different pipe sizes; or change in process setpoint. *See Performing an Auto Tune, Section 4.*

- **Daily**

- Check for leaks in cooling and process lines.**

Before and during operation, you should inspect the unit and all plumbing lines for leaks. If a leak develops, stop the Thermolator and repair it.

- Keep the unit and the area around it clean.**

Check for and remove lint, dust or other obstructions on the unit, especially around air intake areas. Keep the floor around the unit dry.

- Check the process fluid level (IC models).**

Isolated circuit models have an internal reservoir that contains the process fluid. Check the level indicator on the back of the unit to make sure the reservoir contains an adequate amount of process fluid. Refill as needed.

- **Monthly, or as often as needed.**

- Inspect the fluid reservoir (IC models only).**

Check the level switches in the process fluid reservoir for debris or deposits that could interfere with proper operation. Flush and clean the reservoir, if necessary. *See Checking the Reservoir Fluid Level, Section 5.*

- **Quarterly (every 3 months)**

- Inspect power cords, wires and electrical connections.**

Check for loose or frayed wires, burned contacts, and signs of overheated wires. Check exterior power cords to the main power source and from the electrical box to the pump and heating elements. Check the ground wire and thermocouple connections. Replace any wire that appears damaged or has worn or cracked insulation.

Continued

- **Annually (every 12 months)**

- Test and calibrate the unit's control systems.**
The TW-1 and TW-2 control Test Mode checks the operation of displays, control buttons, inputs and outputs. You can also calibrate the supply and return thermocouples. *See Performing System Tests, Section 5.*

PREVENTATIVE MAINTENANCE SCHEDULE FOR TW-1 AND TW-2

CONTINUED



WARNING: Electrical shock and hot surface hazards

Before attempting maintenance of any kind on the Thermolator, you must stop the unit; disconnect and lockout the main power supply; and allow the unit to cool to less than 100°F (38°C)



ACCESSING THE THERMOLATOR ENCLOSURE

To access the Thermolator enclosure:

Remove the top access panel by lifting straight up. Remove the side panels by lifting straight up.

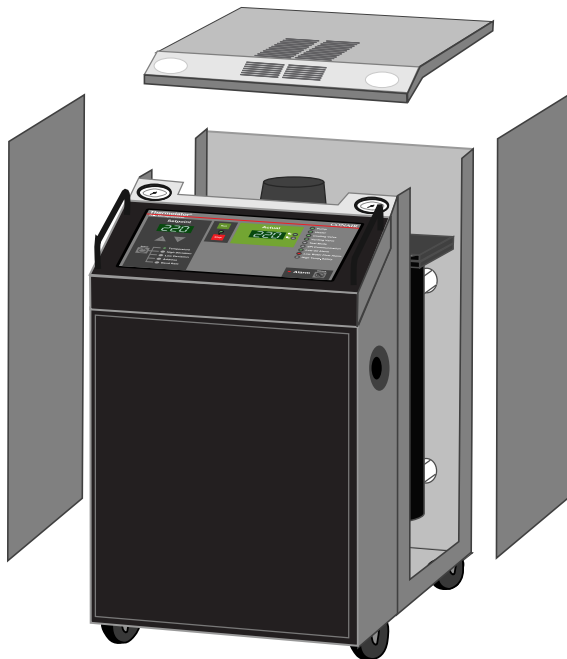

CHECKING THE RESERVOIR FLUID LEVEL

(IC MODELS ONLY)

The isolated, or totally closed circuit models separate the cooling water from the process fluid, which is held in a reservoir inside the unit. This reservoir should be kept at about three-quarters full of the process fluid.

You can check the fluid level in the reservoir using the sight glass on the back of the Thermolator.

To fill the reservoir:

- 1** **Disconnect and lockout power, and remove the top panel of the Thermolator.**
- 2** **Locate the reservoir near the top of the unit.**
- 3** **Locate the fill port at the top of the reservoir.**
- 4** **Refill the reservoir. Monitor the level using the sight glass on the back of the unit. Because IC units can use pure water or glycol mixtures, make sure you are adding the correct fluid for your application.**

IMPORTANT: Do not use deionized water or glycol mixtures containing additives in a Thermolator. Softened water or glycol mixtures with additives, such as automotive fluids, can damage the Thermolator. Glycol/water process loop mixtures should use industrial-grade ethylene or propylene glycol only.

- 5** **Replace the top panel of the Thermolator.**

Conair Thermolators with TW-1 or TW-2 controls provide a Test Mode that tests displays and keys on the control panel, as well as inputs and outputs. The Test Mode also allows calibration of the supply and return line thermocouples.

System tests and calibration should be performed annually.

To enable Test Mode:

- 1 Press **Stop** to shut down the Thermolator.
- 2 Disconnect and lock out main power to the unit, then open the electrical enclosure.
- 3 Set dip switches 3 and 5 to OFF.
- 4 Set dip switch 6 to ON.
- 5 Close the electrical enclosure and restore power to the unit.

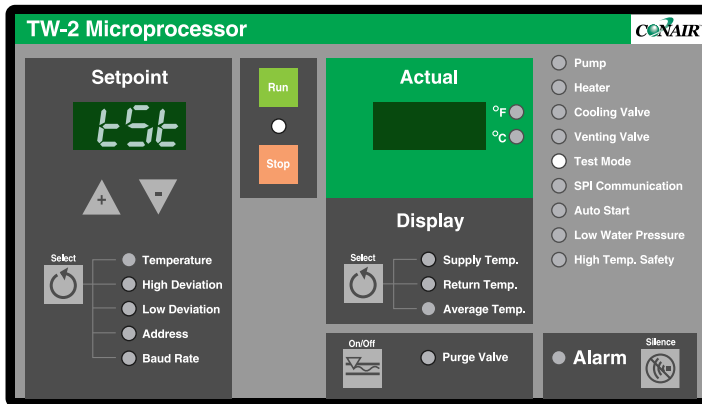
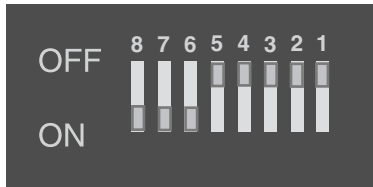

- ◆ The control displays “tSt.”
- ◆ The Test Mode LED lights.

- 6 Press any button to display the first test menu. Test mode provides the following menus:
 - Key/Display Test
 - Input Test
 - Output Test
 - Calibration
 - Total Operating Hours
 - Output Monitor Enable/Disable
- 7 After performing each test, hold the Setpoint  for 3 seconds to index to the next test menu. The procedure for each test is described on the following pages.

TW-1, TW-2 CONTROL PERFORMING SYSTEM TESTS



WARNING: During this test the pump, vent and/ or cooling valve will be energized. Refer to the electrical print.

IMPORTANT: All normal operating functions are disabled while Test Mode is enabled. To return to normal operation, you must disable Test Mode.



To disable Test Mode, repeat steps 2 through 5, setting dip switch 6 to OFF instead of ON.

TW-1, TW-2 CONTROL KEY/DISPLAY TEST

The Key/Display Test verifies the function of displays, LEDs and buttons on the control panel.

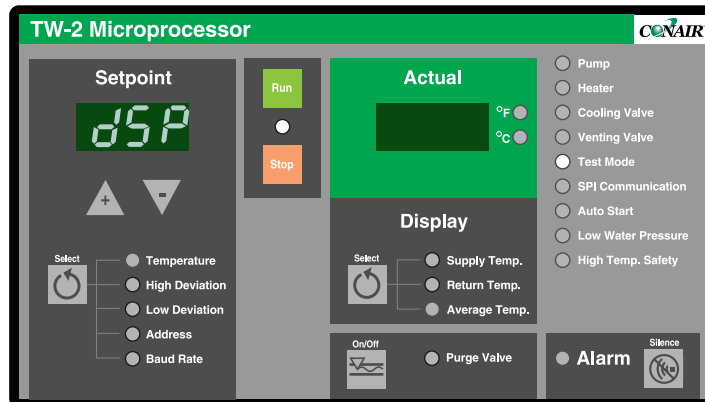
- 1 Enable Test Mode.** See Section 5, TW1, TW2 Control Performing System Tests.
- 2 Press any key.**



- 3 If necessary, index to the Key/Display menu.** Press and hold the Setpoint  key for 3 seconds to index to each test menu until the controller displays “dSP”.
- 4 Press any key to clear all displays.**
- 5 Repeatedly press any key to test displays.** With each key press, a new segment of all six 8-segment LEDs and a select group of LED indicator lights will illuminate.
- 6 Exit the test and enter the next test.** Press and hold the Setpoint  key for 3 seconds to exit and index to the next test.

TW-1, TW-2 CONTROL INPUT TEST

The Input Test verifies the function of inputs available on models with TW-1 or TW-2 controls. Not all inputs are used on all models. The performance evaluation of the inputs is based on the voltage sensing device (VSD).

- 1 Connect all inputs to the system.**
- 2 Enable test mode, press any key to display the first test menu.** See Section 5, TW1, TW2 Control Performing System Tests.

- 3 Select the Input Test menu.**

Press and hold the Setpoint  key for 3 seconds to index to each test menu until the controller displays “InP”.

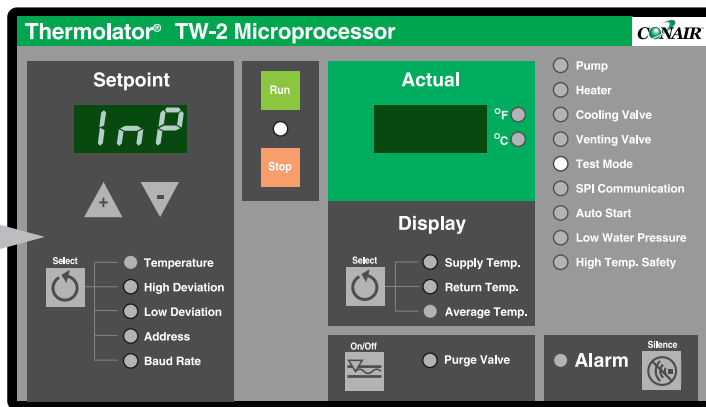

WARNING: During the Control Input test, the pump, vent and cool valve will be energized. Refer to the Electrical print for VSD numbers.

- 4 Repeatedly press and release any key to test.** With each key press and release, the left display will indicate the number of the input being tested (v1, v2, v3, etc.). The right display indicates either “1” for voltage present or “0” for an absence of voltage.

Only inputs that are actually used by the particular model will be tested.

- 5 Exit the test and enter the next test.** Press and hold the Setpoint  key for 3 seconds to exit and index to the next test.

TW-1, TW-2 CONTROL OUTPUT TEST



WARNING: Pump, Vent, Cool and Purge valves will come on during the output test.

The Output Test verifies the function of outputs available on the models with TW-1 or TW-2 controls. Not all outputs are used on all models. The performance evaluation of the inputs is based on the output monitors (OM).

1 Connect all outputs to the system.

IMPORTANT: Testing each output requires the firing of the associated solid state relay. Make sure an output device is connected to the controller, otherwise the test result will be erroneous.

2 Enable Test Mode. See Section 5, TW1, TW2 Control Performing System Tests.

3 Press any key to display the first test menus.

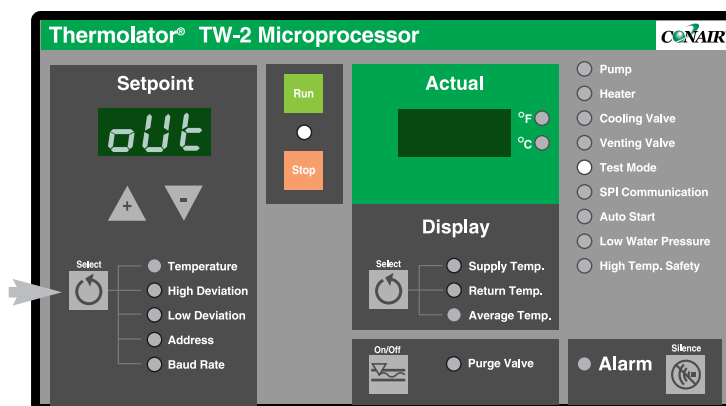

4 Select the Output Test menu.

Press and hold the Setpoint  key for 3 seconds to index to each test menu until the controller displays “oUt”.

5 Repeatedly press and release any key to test.

With each key press and release, the left display will indicate the number of the output being tested (oS1 = OM1; oS2 = OM2; etc.). The right display indicates either “1” for a good output or “O” for a failed output.

Only outputs that are actually used by the particular model will be tested.

6 Exit the test and enter the next test.

Press and hold the Setpoint  key for 3 seconds to exit and index to the next test.



All output monitors on the Thermolator can be enabled or disabled permanently through the OM Enable/Disable Menu in Test Mode.

You need to use this feature if you have replaced the motherboard, or if dip switches 7 and 8 have been changed erroneously. This will enable any required output monitors that were disabled and give fuse failures.

TW-1, TW-2 CONTROL DISABLING OR ENABLING OUTPUT MONITORS

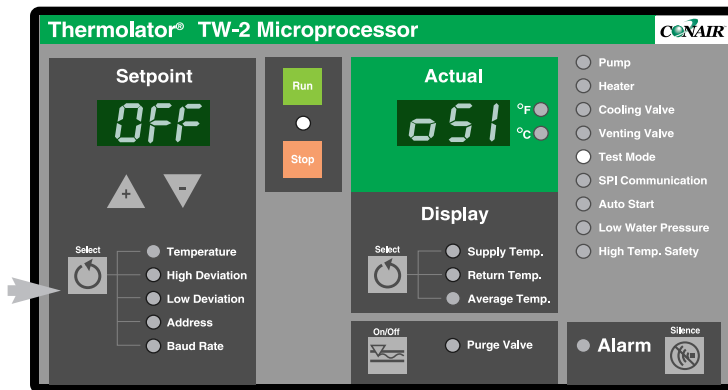

- 1** Enable Test Mode. See Section 5, TW1, TW2 Control Performing System Tests.
- 2** Press any key to display the first test menus.



- 3** Select the OM Enable/Disable menu.
Press and hold the Setpoint  key for 3 seconds to index to each test menu until the controller indicates “oS1” in the actual display and the status of the selected output in the Select display.
- 4** Press the Setpoint  or  key to change the status. Each press of the key changes the output status from ON to OFF or OFF to ON.

OUTPUT MONITOR SELECTION GUIDE			
MODEL TYPE	DI	CC	IC
OM1 Pump	ON	ON	ON
OM2 Heat	ON	ON	ON
OM3 Cool	ON	ON	ON
OM4 Vent	OFF	ON	OFF
OM5 Purge (TW-2 option only)	ON	ON	OFF

NOTE: If option is not installed-turn off Output Monitor

- 5** Press the Setpoint  to select the next output.
Repeat Step 4 to change the status of the output, or press any key to continue indexing through the outputs.
- 6** Save changes and exit the output menu.
Press and hold the Select  key for 3 seconds to save the changes and exit.

TW-1, TW-2 CONTROL CALIBRATING TEMPERATURE SENSORS

Special Tools Needed:

- type K thermocouple calibrator

NOTE: If calibration is performed without simulator and saved, the previous values will not be restored. It must be calibrated. Consult Conair to provide this service.

Thermolators with TW-1 or TW-2 controls use type “K” thermocouples to sense the temperature in the return and supply process lines. These thermocouples should be calibrated annually, or when a new thermocouple is installed, to ensure correct operation.

The Thermolator’s Calibration Mode provides zero and span calibration of both the supply and return line thermocouples. You access the Calibration Mode while in Test Mode.

1 Enable Test Mode.

See Section 5, TW1, TW2 Control Performing System Tests.

2 Press any button to display the first test menu.

3 Select the Calibration Mode menu.

Press and hold the Setpoint  key for 3 seconds to index to each test menu until the controller indicates “SC.L” in the Actual display.

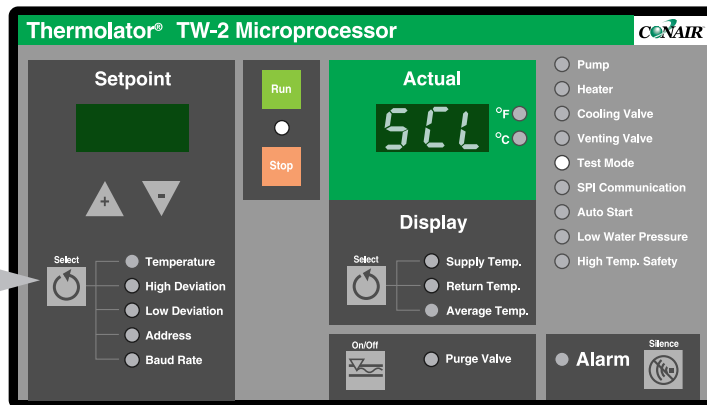

4 Release the Setpoint key.

You are now in calibration mode. Each press and release of this key will exit the current calibration and start the next calibration. The table below lists the calibrations that will be performed.

CALIBRATION	SETPOINT DISPLAY	ACTUAL DISPLAY
Zero Calibrate Supply Sensor	32°F (0°C)	SC.L
Zero Calibrate Return Sensor	32°F (0°C)	rC.L
Span Calibrate Supply Sensor	510°F (266°C)	SC.H
Span Calibrate Return Sensor	510°F (266°C)	rC.H

5 Using the thermocouple simulator, apply the appropriate temperature to the control input.

TW-1, TW-2 CONTROL CALIBRATING TEMPERATURE SENSORS

6 Press the up ▲ key to begin calibrating.

The controller displays the name of the current calibration (examples: 32 SC.L; 32 rC.L; 510 SC.H; or 510 rC.H). Allow simulated value to stabilize for 1 minute between tests to enhance better results.

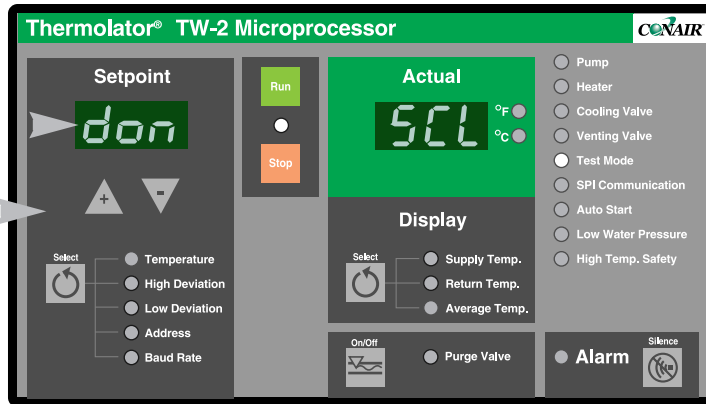

7 Wait until the control displays ‘don’ or ‘bad’.

A “don” message in the Setpoint display indicates the calibration was successful. A “bad” message in the Setpoint display indicates a bad calibration.

NOTE: The original calibration value stored in EEPROM can be restored for the current calibration by pressing the STOP key at any time.

8 Press Select to start the next calibration.

Pressing and releasing the Select  key at the end of a calibration tells the controller to perform the next calibration.

9 Exit Calibration Mode.

Press and hold the Select  key for 3 seconds to exit the Calibration Mode.

You can now proceed to the next test in Test Mode, or disable Test Mode and resume normal operation.



TO DISABLE TEST MODE, complete steps 2 through 5 in “Performing System Tests”, setting dip switch 6 to OFF instead of ON.

TW-1, TW-2 CONTROL LOGGING OPERATING HOURS

You can see the total numbers of operation by accessing the Total Operating Hours Log in Test Mode.

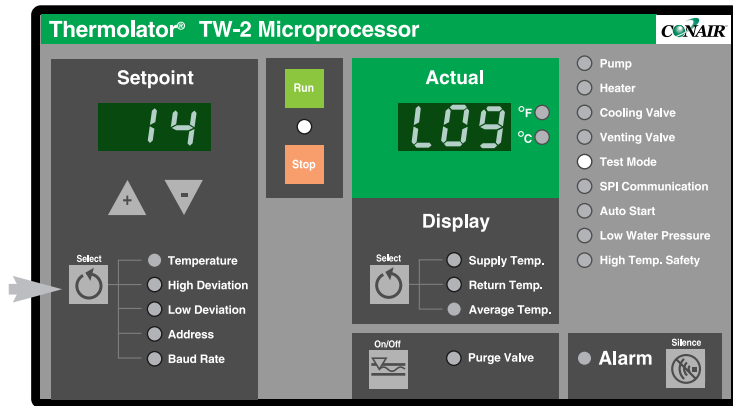
- 1 Enable Test Mode.** See Section 5, *TW1, TW2 Control Performing System Tests*.
- 2 Press any key to display the first test menus.**



- 3 Index through test menus to the operating log.**
Press and hold the Setpoint  key for 3 seconds to index to each test menu until the Actual display indicates “Log”. The Setpoint display indicates the total number of operating hours in 100-hour units.
- 4 Exit the Operating Hours Log.**
Press and hold the Select  key for 3 seconds to exit and index to the next test.

You can now proceed to another menu in Test Mode, or disable Test Mode and resume normal operation.

TO DISABLE TEST MODE, complete steps 2 through 5 in “Performing System Tests, Section 5” setting dip switch 6 to OFF instead of ON.

The Thermolator Direct Injection Model has a Pulse Mode in which software pulses the cool and vent valves at a predetermined rate under normal control and autotune when **all** of the following conditions are met.

- **The Control Point temperature is less than 245°F.**
- **The setpoint is greater than the control point temperature by more than 5°F.**

Pulse Mode is used to relieve excess pressure that can build up from thermal expansion of water in the process loop. The Pulse Time and Pulse Cycle Time parameters are adjustable under Test Mode. Pulse Time is the time in which the cool and vent valves shall be activated within the pulse cycle. Pulse Cycle Time determines the cycle time for each pulse to be repeated. The cycle time can be set to 'OFF' to disable Pulse Mode.

Pulse Mode Setup establishes the characteristics of the pulse in Thermolator Direct Injection Model's Pulse Mode.

To access the Pulse Mode Setup:

- 1 Follow Steps 1 through 7 in Test mode until "P.Cy" displays on the Actual screen.** This is the Pulse Cycle Time parameter. *See Section 5, TW1, TW2 Control Performing System Tests.*
- 2 Release the Parameter Select button.**
The left display shows the Pulse Cycle Time value.
- 3 Use the UP and DOWN Arrow buttons to set a new Pulse Cycle Time value.**
- 4 Momentarily press and release the Setpoint Select button** to save the newly entered Pulse Cycle Time value into non-volatile memory. P.tI displays on the Actual display. This is the Pulse Time parameter.
- 5 Use the UP and DOWN Arrow buttons to set a new Pulse Time value.**
- 6 Momentarily press and release the Setpoint Select button** to save the newly entered Pulse Time value to non-volatile memory.
- 7 Press and hold the Setpoint Select button for 3 seconds** to exit Pulse Mode Setup and to enter the next service on the menu.

TW-1, TW-2 CONTROL PULSE MODE DESCRIPTION

TW-1, TW-2 CONTROL PULSE MODE SETUP

IMPORTANT: If the Parameter Select button is not pressed after a new value is entered, then the newly entered value is not saved to non-volatile memory.

TW-1, TW-2 PULSE MODE LIMITS AND DEFAULTS

The table lists the limits and defaults for the pulse mode parameters.

Parameter	Low Limit	High Limit	Default Value
Pulse Cycle Time	Off, 0.1 minute	15.0 minutes	Off
Pulse Time	0.5 seconds	5 seconds	1 second

When the Pulse Cycle Time is set to Off the Pulse Mode is disabled.

TW-1, TW-2 DEVIATION ALARM/BAND AND DELAY

Whenever the process value is within the alarm band, the alarm delay shall be canceled. The deviation alarm delay timer only starts when out of dead band.

Follow these steps to access the deviation alarm inhibition/delay parameters:

The table lists the limits and defaults for the Alarm Inhibition/Alarm Delay parameters. The values are adjustable in 0.5 minute increments.

Parameter	Low Limit	High Limit	Default Value
Alarm Delay Time	1.0 second	1800 seconds	600 seconds
Deviation Band	1°F	45°F	20°F

- 1** Follow Steps 1 through 7 in Test Mode until “A.In” is displayed on the right display. This is the Alarm Inhibition Time item.
- 2** Release the Parameter Select button.
The left display shows the Alarm Inhibition Time value.
- 3** Use the UP and DOWN Arrow buttons to set a new Alarm Inhibition Time value.
- 4** Momentarily press and release the Parameter Select button to save the new Alarm Inhibition Time value into non-volatile memory. The Actual display scrolls to the ‘A.dY’ (Alarm Delay Time) item.
- 5** Use the UP and DOWN Arrows to set a new Alarm Delay Time value.
- 6** Press and release the Parameter Select button to save the new setting into non-volatile memory.
- 7** Press and hold the Parameter Select button to exit Alarm Delay/Alarm Inhibition, and enter the next service on the menu.

TW PLUS DEVIATION ALAMR/BAND AND DELAY







- 1** Follow Steps 1 through 7 in Test Mode until “A.In” is displayed on the right display. This is the Alarm Inhibition Time item.
- 2** Release the Parameter Select button.
The left display shows the Alarm Inhibition Time value, (dSP is shown).
- 3** Use the UP and DOWN Arrow buttons to set a new Alarm Inhibition Time value, 20°F default
- 4** Momentarily press and release the Parameter Select button to save the new Alarm Inhibition Time value into non-volatile memory. The Actual display scrolls to the ‘A.dY’ (Alarm Delay Time) item.
- 5** Use the UP and DOWN Arrows to set a new Alarm Delay Time value.
- 6** Press and release the Parameter Select button to save the new setting into non-volatile memory. (ddt is now in display)
- 7** Use the UP and DOWN Arrow buttons to set a new Alarm Inhibition Time value. (600 seconds default)
- 8** Momentarily press and release the Parameter Select button to save the new Alarm Inhibition Time value into non-volatile memory. The Actual display scrolls to the ‘A.dY’ (Alarm Delay Time) item.
- 9** Use the UP and DOWN Arrows to set a new Alarm Delay Time value.
- 10** Press and release the Parameter Select button to save the new setting into non-volatile memory.

TW PLUS CONTROL VENT TIMER ADJUSTMENT

When the unit starts, i.e. on/off is pressed the Vent sequence is initiated.

The venting sequence is divided into two phases. In the first phase the cool output energize for the set venting sequence time, Ut1. This is followed by a second phase in which the cool, and pump outputs are energized for the Ut2 time.

To access the Vent Timer setups:

- 1** Press and hold the “setpoint/function” key till Uni is shown on screen. 
- 2** Press the “down” key till ut1 is shown on screen. 
- 3** Press the “setpoint/function” key to display the value. (15 second default). 
- 4** Press the “up/down” keys to change the value. 

- 5** Press the “setpoint/function” key to accept the change in value. 
- 6** Wait for time out to return to temp. screen

Vent Bypass

If the unit remains full of fluid and it is not advantageous to vent the unit may be bypassed on start-up.

- 1** Press and hold  until the Vent cycle is skipped, control begins immediately.

TROUBLESHOOTING

- *Before Beginning*6-2
- *A Few Words of Caution*6-2
- *Identifying the Cause of a Problem for the TW Plus Control*6-3
- *Identifying the Cause of a Problem for the TW-1, TW-2 Control*6-4
- *TW Control Alarms*6-5
- *TW Plus Control Mechanical/Electrical Alarms*6-11
- *TW-1, TW-2 Control Shut Down Alarms* ...6-12
- *TW-1, TW-2 Control Warning Alarms*6-13
- *TW-1, TW-2 Control Other Warnings*6-15
- *TW-1, TW-2 Control System Alarms*6-16
- *Thermolator Will Not Power Up*6-17
- *Replacing the TW Plus Control*6-18
- *Checking and Replacing Fuses*6-19
- *Resetting Overloads*6-20
- *Replacing Pump Overload*6-20
- *Replacing the Motherboard*6-21
- *Replacing the Heater Contactor*6-22
- *Checking Thermocouples*6-23
- *Replacing Thermocouples*6-23
- *PT1000 Sensor Readings TW Plus Control*6-24
- *Repairing Cooling Valves*6-25
- *Repairing Solenoid Valves*6-26
- *Repairing Modulating Valves*6-27
- *Replacing Heater Elements*6-28
- *Removing the Pump*6-30
- *Disassembling and Assembling 3/4 - 2 HP Pumps*6-31
- *Disassembling and Assembling 3 - 7.5 HP Pumps*6-32

BEFORE BEGINNING

You can avoid most problems by following the recommended installation, operation and maintenance procedures outlined in this User Guide. If you do have a problem, this section will help you determine what caused it and tell you how to fix it.

Before you begin troubleshooting:

- ❑ **Find the wiring, plumbing or other diagrams** that were shipped with your equipment. These diagrams are the best reference for correcting a problem. The diagrams also will note any custom features, such as special wiring, control or plumbing options, not covered in this User Guide.
- ❑ **Verify that you have manuals for other equipment** in the process line. Solving problems may require troubleshooting malfunctions or incorrect operating procedures on other pieces of equipment.
- ❑ **If an alarm is present, note any indicator lights** and messages shown on the control panel. These indicators will help you discover the cause of the problem more quickly.

A FEW WORDS OF CAUTION

The Thermolator is equipped with many safety devices. Do not remove or defeat them. Improper corrective action can lead to hazardous conditions, and should never be attempted to sustain production.



WARNING: This machine should be adjusted and serviced only by qualified technical personnel who are familiar with construction and operation of this type of equipment.



WARNING: Hot surfaces and liquids
Allow the Thermolator to cool to below 100°F (38°C) before servicing the unit.



DANGER: Voltage hazard.

Troubleshooting the electrical system of this equipment requires use of precision electronic measuring equipment, and may require access to the electrical enclosure while power is on. Exposure to potentially fatal voltage levels may be unavoidable. These troubleshooting procedures should be performed only by qualified electrical technicians who know how to use this precision electronic equipment and who understand the hazards involved.

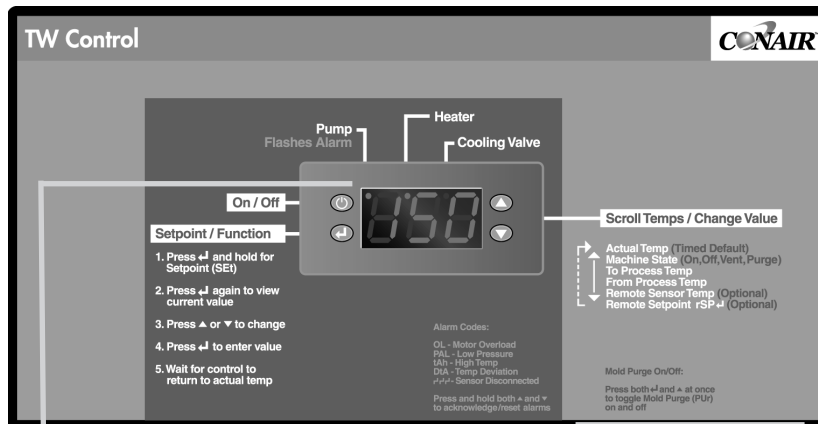

Illuminated alarm lights and error codes on the temperature controller will alert you to many malfunctions. If the optional alarm package is installed, an audible alarm also will activate.

IDENTIFYING THE CAUSE OF A PROBLEM FOR THE TW PLUS CONTROL



Standard indicator lights and alarm codes.
See Controller Alarms

When an Alarm condition occurs:

- 1** Note any indicator lights or error messages to help determine the cause of the problem.
- 2** Press the up/down buttons to silence optional audible alarm.  
- 3** Find the alarm or error code in the diagnostics tables in this section of the User Guide. Causes are listed in the order of most likely to least likely problem.
- 4** Determine and fix the cause of the alarm.



WARNING: Always disconnect and lock out the main power source before opening the Thermolator or its electrical enclosure.

Disconnect air and water supply lines as needed.

IDENTIFYING THE CAUSE OF A PROBLEM FOR THE TW-1, TW-2 CONTROL

Most Thermolator malfunctions are indicated by an illuminated alarm light and error codes displayed on the control panel.

A problem can trigger three types of alarms:

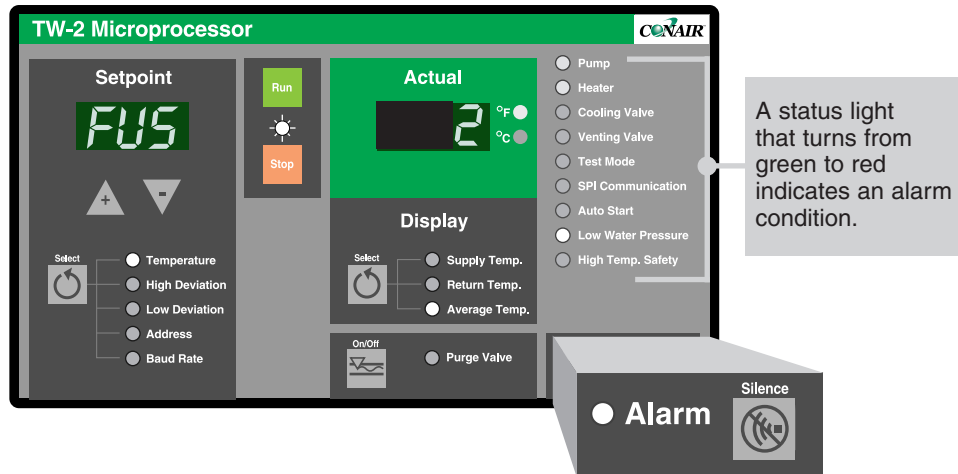

- **Shut Down Alarms:** The Thermolator detected a problem that caused it to shut down automatically to prevent equipment damage or personal injury.
- **Warning Alarms:** The Thermolator continues to operate, but warns of a problem that could lead to a condition that will shut down the unit.
- **System Errors:** The system error codes indicate a non-recoverable problem with the microprocessor control.

When the Thermolator control detects a problem, the red Alarm light is activated and the RUN/STOP light changes from green to flashing red.



WARNING: Disconnect and lockout the main power source before opening the Thermolator or its electrical enclosure for servicing. Disconnect air and water supply lines as needed.

When an Alarm condition occurs:

- 1 Press  to silence any optional audible or visual alarm. The RUN/STOP light changes from flashing red to steady red.
- 2 Note any indicator lights or error messages to help determine the cause of the problem.
- 3 Find the alarm or error code in the diagnostics tables in the Troubleshooting section of this manual.
- 4 If the unit is still operating, press  to clear the alarm and shut down the Thermolator to correct the problem.
- 5 Press  to resume normal operation after the problem is corrected.

TW PLUS CONTROL ALARMS

The Thermolator has detected a problem that could lead to equipment damage or personal injury if it is not corrected.

- ◆ The controller displays a red alarm LED or an error code indicating the cause of the problem.
- ◆ If the optional alarm package is installed, the Fault button will illuminate and the audible alarm will activate.

Alarm	Possible cause	Solution
<p>tAh</p> <p>The actual temperature of water supplied to the process exceeds the 260°F safety limit.</p> <p> WARNING: Only qualified electrical service personnel should examine and correct problems that require opening the unit's electrical enclosure or checking electrical current to diagnose the cause of a problem.</p>	<p>Water stopped flowing through the unit or between the supply outlet and return inlet.</p> <p>The heater contactor failed.</p> <p>The optional electro-mechanical high temperature safety switch been installed on this unit.</p>	<ul style="list-style-type: none"> <input type="checkbox"/> Verify that the unit is running and that the pump is working. <input type="checkbox"/> Check for closed or defective cooling or vent valves and plugged lines. <i>See Section 6, Repairing Solenoid Valves.</i> <p>Replace the contactor if defective. <i>See Section 6, Replacing the Heater Contactor.</i></p> <p>Verify the switch setting. A setting too low will cause nuisance trips. Check the switch and replace if defective. <i>See Section 6, Checking and Replacing Switches.</i></p>
<p>dtA</p> <p>The Thermolator will not maintain the setpoint temperature, or takes too long to reach the setpoint temperature range. The actual temperature of water supplied to the process is outside the setpoint deviation alarm band. dsp - factory default 20°F</p>	<p>The actual temperature of the process fluid is more than than the dSP setpoint temperature.</p> <p>The actual temperature of the process fluid is less than than the dSP setpoint temperature.</p>	<p>Follow the troubleshooting procedures in the table, <i>See Section 6, High Setpoint Deviation.</i></p> <p>Follow the troubleshooting procedures in the table, <i>See Section 6, Low Setpoint Deviation.</i></p>

TW PLUS CONTROL ALARMS

The Thermolator has detected a problem that could lead to equipment damage or personal injury if it is not corrected.

- ◆ The controller displays a flashing red alarm LED or an error code indicating the cause of the problem.
- ◆ If the optional alarm package is installed, the visual or audible alarm will activate.

Alarm	Possible cause	Solution
<p>High Setpoint Deviation</p> <p>The Thermolator will not cool down, or takes too long to cool down. The actual temperature of fluid supplied to the process is higher than the setpoint deviation allows.</p>	<p>Water has stopped flowing between supply outlet and return inlet.</p>	<p>Check for a plugged pipe or closed valve.</p>
<p> WARNING:</p> <p>The Thermolator should be tested and repaired only by qualified technicians equipped with the correct tools and trained in the maintenance and repair of electrical systems and industrial appliances.</p>	<p>The cooling valve failed to open.</p>	<p>Check the cooling valve seat for debris clogging the orifice. <i>See Section 6, Repairing Solenoid Valves or Motorized Cooling Valves.</i></p>
	<p>The cooling water outlet has restrictions</p>	<p>Verify the line valves opened and check for pipe restrictions.</p>
	<p>The temperature difference between the cooling water supply and the setpoint is too small.</p>	<p>The temperature difference should be at least 25°F to achieve proper cooling. Increase the process setpoint, decrease the cooling water supply temperature or increase the cooling water supply pressure.</p>
	<p>A heater contactor failed-close.</p>	<p>With power on and the Heater LED lit: Check the amp draw on each of the three phase legs to the heater. All should match the FLA listed for the heater on the unit nameplate. Replace the heater contactor if there is a voltage imbalance greater than 10%. With power off there should be no resistance between L1 and T1, L2 and T2, L3 and T3 on the contactor. <i>See Section 6, Replacing the Heater Contactor.</i></p>
	<p>The cooling valve under-sized for the application.</p>	<p>Check the cooling load (Btu/hr) for which the valve was specified.</p>
<p>The deviation temperature band is too narrow.</p>	<p>Increase the deviation band. The recommended setting is the setpoint plus/minus 2°F to 10°F .</p>	

The Thermolator has detected a problem that could lead to equipment damage or personal injury if it is not corrected.

- ◆ The controller displays a red alarm LED or an error code indicating the cause of the problem.
- ◆ If the optional alarm package is installed, the Fault button will illuminate and the audible alarm will activate.

TW PLUS CONTROL ALARMS

Alarm	Possible cause	Solution
<p>Low Setpoint Deviation</p> <p>The Thermolator will not heat to the setpoint temperature, or takes too long to reach the setpoint temperature. The actual temperature of fluid supplied to the process is lower than the setpoint deviation band dsp allows.</p> <p> WARNING: The Thermolator should be tested and repaired only by qualified technicians equipped with the correct tools and trained in the maintenance and repair of electrical systems and industrial appliances.</p>	<p>The cooling valve is stuck open or leaking water.</p>	<p>Disassemble the cooling valve and check for particles blocking the valve seat. Check the valve seat for excessive wear. Replace as required using a valve repair kit. <i>See Section 6, Repairing Solenoid Valves.</i></p>
	<p>A heater element failed.</p>	<p>With the unit powered down: Check for loose connections. Check resistance between the phase legs on the output side of the heater contactor. Readings should be within 0.25 ohms of each other. Replace the heater, if necessary. <i>See Section 6, Replacing Heater Elements.</i></p>
	<p>A heater contactor failed to open.</p>	<p>With power on and the Heater LED lit: Check the amp draw on each of the three phase legs to the heater. All should match the FLA listed for the heater on the unit nameplate. Replace the heater contactor if there is a voltage imbalance greater than 10%. <i>See Section 6, Replacing the Heater Contactor.</i></p>
	<p>The deviation temperature band dsp is too narrow.</p>	<p>Increase the deviation band setting. The recommended setting is the setpoint plus/minus 2°F to 10°F.</p>
	<p>The Thermolator is under-sized for the application.</p>	<p>Review specifications and selection guidelines that apply to heater and pump sizes in temperature control units.</p>

TW PLUS CONTROL ALARMS

The Thermolator has detected a problem that could lead to equipment damage or personal injury if it is not corrected.



- ◆ The controller displays a red alarm LED and/or an error code indicating the cause of the problem.

Alarm	Cause	Solution
<p>PAL</p> <p>Low Water Pressure</p> <p>The cooling water pressure is less than 25 psi.</p> <p>Note: The unit will restart automatically after a two-second delay if the water pressure returns to at least 25 psi.</p> <p>Factory pressure switch setting: 25 psig cut in, 15 psig cut out</p>	<p>The water supply pressure is below 25 psi.</p>	<p>Verify that the water supply is on and delivering water at a pressure of at least 25 psi. Check for closed valve or faulty pump in the supply circuit.</p>
	<p>The pressure switch failed.</p>	<p>Watch gauges while turning cooling water on and off. If pressure vents automatically, check vent or cooling valve.</p>
	<p>The cooling valve failed.</p>	<p>Check cooling valve. <i>See Repairing the Cooling Valve.</i></p>
	<p>Pressure remains above 25 psig</p>	<p>Check sensing port for restrictions.</p>
<p>OL</p> <p>The pump motor overload has tripped. The contact is open.</p> <p> WARNING: Only qualified electrical service personnel should examine and correct problems that require opening the unit's electrical enclosure or checking electrical current to diagnose the cause of a problem.</p>	<p>The incorrect voltage is supplied to the pump motor.</p>	<p>Supply voltage should match the rating on the pump name plate. If voltage is correct, check wiring connections. See motor data tag, with unit running obtain to and from process pressure. Subtract to and from for pump performance. See pump curve to verify flow performance, Appendix B-1</p>
	<p>The required water flow is greater than the pump's capacity.</p>	<ul style="list-style-type: none"> <input type="checkbox"/> Review pump sizing for the application. <input type="checkbox"/> Decrease the process water flow.
	<p>The motor overload is faulty or set incorrectly.</p>	<p>Disconnect the power and open the electrical enclosure. Verify that the overload is set to trip at the proper amperage, which should not exceed the FLA. Manually trip and reset the overload. Verify SF rating on motor data tag, multiply by FLA to obtain max o l setting. If the problem continues, replace the overload. <i>See Section 6, Resetting and Replacing Overloads.</i></p>
	<p>The pump is not working properly.</p>	<p>Replace the pump if supply voltage, wiring and overload settings are correct, but the pump continues to draw excessive current.</p>

The Thermolator has detected a problem that could lead to equipment damage or personal injury if it is not corrected.

- ◆ The Alarm LED lights and the STOP/RUN LED flashes red.
- ◆ The Thermolator automatically shuts down.
- ◆ The control displays a red LED or alarm code indicating the source of the problem.

TW-1, TW-2 CONTROL SHUT DOWN ALARMS

Alarm	Possible cause	Solution
<p>● High Temp. Safety</p> <p>The actual temperature of water supplied to the process exceeds the optional mechanical safety switch limit setting.</p> <p> WARNING: Only qualified electrical service personnel should examine and correct problems that require opening the unit's electrical enclosure or checking electrical current to diagnose the cause of a problem.</p>	<p>Water stopped flowing through the unit or between the supply and return.</p> <p>Faulty wiring</p> <p>The optional electro-mechanical safety switch is improperly set or defective.</p> <p>The heater contactor has failed-closed.</p>	<p><input type="checkbox"/> Verify that the unit is running and that the pump is working.</p> <p><input type="checkbox"/> Check for closed or defective cooling or vent valves and plugged lines. <i>See Section 6, Repairing Solenoid Valves .</i></p> <p>Verify wiring to normally closed switch. Input “jumped” if not installed.</p> <p>Check the switch setting. A setting that is too low will cause nuisance trips. Check the switch and replace if defective. <i>See Section 6, Checking and Replacing Switches.</i></p> <p>Replace the contactor if defective. <i>See Section 6, Replacing the Heater Contactor.</i></p>
<p>Hi SAF</p> <p>The actual temperature of water supplied to the process exceeds the programmed 260°F-DI, CC, 190°F-IC, VTR safety limit.</p> <p> WARNING: Only qualified electrical service personnel should examine and correct problems that require opening the unit's electrical enclosure or checking electrical current to see the cause of a problem.</p>	<p>Water stopped flowing through the unit or between the supply and return.</p> <p>The heater contactor failed.</p> <p>Note: slaved to “control point source select” setting if TW-2</p> <p>TW-1 slaved to average temperature</p>	<p><input type="checkbox"/> Verify that the unit is running and that the pump is working.</p> <p><input type="checkbox"/> Check for closed or defective cooling or vent valves and plugged lines. <i>See Section 6, Repairing Solenoid Valves.</i></p> <p>Replace the contactor if defective. <i>See Section 6, Replacing the Heater Contactor.</i></p>

TW-1, TW-2 CONTROL SHUT DOWN ALARMS

The Thermolator has detected a problem that could lead to equipment damage or personal injury if it is not corrected.

- ◆ The Alarm LED lights and the STOP/RUN LED flashes red.
- ◆ The Thermolator automatically shuts down.
- ◆ The control displays a red LED or alarm code indicating the source of the problem.

Alarm	Possible cause	Solution
<p>● Low Water Pressure The cooling water pressure is less than 25 psi.</p> <p>Note: The unit will re-start automatically after a two-second delay if the water pressure returns to at least 25 psi.</p>	The water supply pressure is below 25 psi.	Verify that the water supply is on and delivering water at a pressure of at least 25 psi. Check for closed valve or faulty pump in the supply circuit.
	The pressure switch failed.	Watch gauges while turning cooling water on and off. If pressure vents automatically, check vent or cooling valve.
	The cooling valve failed.	Check the cooling valve. <i>See Section 6, Repairing Solenoid Valves or Motorized Cooling Valves.</i>
<p>● Pump PUMP LED is RED The pump motor overload has tripped. The contact is open.</p> <p> WARNING: Only qualified electrical service personnel should examine and correct problems that require opening the unit's electrical enclosure or checking electrical current to diagnose the cause of a problem.</p>	The incorrect voltage is supplied to the pump motor.	Supply voltage should match the rating on the pump name plate. If voltage is correct, check wiring connections.
	The required water flow is greater than the pump's capacity.	<input type="checkbox"/> Review pump sizing for the application. <input type="checkbox"/> Decrease the process water flow.
	The motor overload is faulty or set incorrectly.	Disconnect the power and open the electrical enclosure. Verify that the overload is set to trip at the proper amperage, which should not exceed the FLA. Manually trip and reset the overload. If the problem continues, replace the overload. <i>See Section 6, Resetting and Replacing Overloads.</i>
	The pump is not working properly.	Replace the pump if supply voltage, wiring and overload settings are correct, but the pump continues to draw excessive current.
	The pump contactor coil is defective	Check coil resistance-replace open circuit if necessary. Verify all jumpers are installed on the motherboard, pump circuit wiring and terminations.
	Contactor pulls in and then alarms during vent mode	Control power is below 108VAC-see unit data tag for unit voltage needed. NOTE: you should have 120VAC at terminal #6-PMP AUX - at power up. Check jumpers - See PD2 or PD3 for references.

The Thermolator has detected a problem that could lead to equipment damage or personal injury if it is not corrected.

- ◆ The Alarm LED lights and the STOP/RUN LED flashes red.
- ◆ The Thermolator automatically shuts down.
- ◆ The control displays a red LED or alarm code indicating the source of the problem..

TW-1, TW-2 CONTROL SHUT DOWN ALARMS

Alarm	Possible cause	Solution
<div style="display: flex; justify-content: space-around;"> <div style="border: 1px solid black; padding: 2px; background-color: #333; color: white; width: 40px; text-align: center;">PHS</div> <div style="border: 1px solid black; padding: 2px; background-color: #6aa84f; color: white; width: 40px; text-align: center;">Err</div> </div> <p>The incoming power is out of phase. A leg may have failed or is disconnected.</p> <p>NOTE: This alarm is available only on models with TW-2 control.</p>	<p>The pump is rotating in the wrong direction.</p>	<p>Check pump rotation against the arrow stamped on the pump. If the pump is rotating in the wrong direction, disconnect and lockout the main power source. Open the electrical enclosure, and reverse any two leads on the incoming power connection.</p>
	<p>One of the main supply wire leads has disconnected.</p>	<p>Disconnect power and open the electrical enclosure. Check for loose connections in main supply and on motherboard.</p>
	<p>If Pump rotation is already correct:</p>	<p>Swap any two heads on Motherboard 3 phase input.</p>
<div style="display: flex; justify-content: space-around;"> <div style="border: 1px solid black; padding: 2px; background-color: #333; color: white; width: 40px; text-align: center;">FUS</div> <div style="border: 1px solid black; padding: 2px; background-color: #6aa84f; color: white; width: 40px; text-align: center;">002</div> </div> <p>Pump fuse.</p> <div style="display: flex; justify-content: space-around;"> <div style="border: 1px solid black; padding: 2px; background-color: #333; color: white; width: 40px; text-align: center;">FUS</div> <div style="border: 1px solid black; padding: 2px; background-color: #6aa84f; color: white; width: 40px; text-align: center;">003</div> </div> <p>Heater fuse.</p> <div style="display: flex; justify-content: space-around;"> <div style="border: 1px solid black; padding: 2px; background-color: #333; color: white; width: 40px; text-align: center;">FUS</div> <div style="border: 1px solid black; padding: 2px; background-color: #6aa84f; color: white; width: 40px; text-align: center;">004</div> </div> <p>Cooling valve fuse.</p> <div style="display: flex; justify-content: space-around;"> <div style="border: 1px solid black; padding: 2px; background-color: #333; color: white; width: 40px; text-align: center;">FUS</div> <div style="border: 1px solid black; padding: 2px; background-color: #6aa84f; color: white; width: 40px; text-align: center;">005</div> </div> <p>Vent valve fuse.</p> <div style="display: flex; justify-content: space-around;"> <div style="border: 1px solid black; padding: 2px; background-color: #333; color: white; width: 40px; text-align: center;">FUS</div> <div style="border: 1px solid black; padding: 2px; background-color: #6aa84f; color: white; width: 40px; text-align: center;">006</div> </div> <p>Purge valve fuse.</p>	<p>The indicated device has blown a fuse.</p>	<p>Disconnect and lockout the main power. Open the electrical enclosure. Check for loose wires and incorrectly installed jumpers or terminal blocks associated with the fuse error. Replace the fuse, if necessary.</p>
	<p>The incorrect device is being used for this fuse location.</p>	<p><i>See Section 6, Checking and Replacing Fuses.</i> Replace the fuse, then enter Test Mode. Turn off the Output Monitor associated with the fuse location and test outputs.</p>
	<p>The motherboard output monitor at the designated output failed.</p>	<p><i>See Section 5, Performing System Tests and Disabling or Enabling Output Monitors.,</i> Replace the motherboard. <i>See Section 6, Checking and Replacing the Motherboard.</i></p>

TW-1, TW-2 CONTROL SHUT DOWN ALARMS

The Thermolator has detected a problem that could lead to equipment damage or personal injury if it is not corrected.

- ◆ The Alarm LED lights and the STOP/RUN LED flashes red.
- ◆ The Thermolator automatically shuts down.
- ◆ The control displays a red LED or alarm code indicating the source of the problem.

Alarm	Possible cause	Solution
<div style="display: flex; justify-content: space-around;"> <div style="border: 1px solid black; padding: 2px; background-color: #333; color: white; width: 40px; text-align: center;">Lo</div> <div style="border: 1px solid black; padding: 2px; background-color: #6aa84f; color: white; width: 40px; text-align: center;">SAF</div> </div> <p>Actual temperature of water supplied to the process is below the programmed 20° F safety limit.</p>	The cooling valve is stuck open.	Disassemble the cooling valve and check for particles blocking the valve seat. Check the valve seat for excessive wear. Replace parts as required using a valve repair kit. <i>See Section 6, Repairing Solenoid Valves.</i>
	The heater failed.	Check for a bad heating element, or a heater contactor that failed in the open position. <i>See Section 6, Replacing the Heater Contactor and Replacing Heater Elements.</i>
<div style="display: flex; justify-content: space-around;"> <div style="border: 1px solid black; padding: 2px; background-color: #333; color: white; width: 40px; text-align: center;">Pbr</div> <div style="border: 1px solid black; padding: 2px; background-color: #6aa84f; color: white; width: 40px; text-align: center;">Err</div> </div> <p>The thermocouple in the process return line failed.</p>	The thermocouple is loose.	Check for a loose thermocouple or loose wire connections to the thermocouple.
	The thermocouple failed.	Check the thermocouple and replace if necessary. <i>See Section 6, Checking and Replacing Thermocouples.</i>
<div style="display: flex; justify-content: space-around;"> <div style="border: 1px solid black; padding: 2px; background-color: #333; color: white; width: 40px; text-align: center;">PbS</div> <div style="border: 1px solid black; padding: 2px; background-color: #6aa84f; color: white; width: 40px; text-align: center;">Err</div> </div> <p>The thermocouple in the process supply line failed.</p>	The thermocouple is loose.	Check for a loose thermocouple or loose wire connections to the thermocouple.
	The thermocouple failed.	Check the thermocouple and replace if necessary. <i>See Section 6, Checking and Replacing Thermocouples.</i>

The Thermolator has detected a problem that could lead to a shut down condition if it is not corrected.

- ◆ The Alarm LED lights.
- ◆ The Thermolator continues operating.
- ◆ The control displays a red LED or alarm code indicating the source of the problem.

TW-1, TW-2 CONTROL WARNING ALARMS

Alarm	Possible cause	Solution
<p>● High Deviation</p> <p>The Thermolator will not cool down, or takes too long to cool down. The actual temperature of fluid supplied to the process is higher than the setpoint deviation allows.</p> <p> WARNING: The Thermolator should be tested and repaired only by qualified technicians equipped with the correct tools and trained in the maintenance and repair of electrical systems and industrial appliances.</p>	<p>Water stopped flowing between the supply and return.</p>	<p>Check for a plugged pipe or closed valve.</p>
	<p>The cooling valve failed.</p>	<p>Check the cooling valve. <i>See Section 6, Repairing Solenoid Valves or Motorized Cooling Valves.</i></p>
	<p>The temperature difference between the cooling water supply and the setpoint is too small.</p>	<p>The temperature difference should be at least 25°F to achieve proper cooling. Increase the process setpoint, decrease the cooling water supply temperature, or increase cooling water supply pressure.</p>
	<p>A heater contactor failed.</p>	<p>With power on and the unit in stop mode, check for voltage from T1, T2 and T3 to ground. If voltage is present replace the heater contactor. <i>See Section 6, Replacing the Heater Contactor.</i></p>
	<p>The cooling valve is the wrong size.</p>	<p>Check the cooling load (Btu/hr) for which the valve was specified.</p>
	<p>The high deviation temperature is set too low.</p>	<p>Increase the high deviation setpoint. The recommended setting is 2°F to 10°F .</p>
	<p>The alarm inhibit time is set too short for the process.</p>	<p><i>See Section 5, Control Deviation Alarm/Inhibition Delay.</i></p>

TW-1, TW-2 CONTROL WARNING ALARMS

The Thermolator has detected a problem that could lead to a shut down condition if it is not corrected.

- ◆ The Alarm LED lights.
- ◆ The Thermolator continues operating.
- ◆ The control displays a red LED or alarm code indicating the source of the problem.

Alarm	Possible cause	Solution
<p>● Low Deviation</p> <p>The Thermolator will not heat to the setpoint temperature, or takes too long to reach the setpoint temperature. The actual temperature of fluid supplied to the process is lower than the setpoint deviation allows.</p> <p> WARNING: The Thermolator should be tested and repaired only by qualified technicians equipped with the correct tools and trained in the maintenance and repair of electrical systems and industrial appliances.</p>	<p>The cooling valve is stuck open or leaking water.</p> <p>A heater element failed.</p> <p>A heater contactor failed.</p> <p>The low deviation temperature is set too low.</p> <p>The Thermolator is incorrectly sized for the application.</p> <p>The alarm inhibit time is set too short for the process.</p>	<p>Disassemble the cooling valve and check for particles blocking the valve seat. Check the valve seat for excessive wear. Replace as required using a valve repair kit. <i>See Section 6, Repairing Solenoid Valves.</i></p> <p>With the unit powered down: Check for loose connections. Check resistance between the phases on the output side of the heater contactor. Readings should be within 0.25 ohms of each other. Replace the heater, if necessary. <i>See Section 6, Replacing Heater Elements.</i></p> <p>With power on and the Heater LED lit: Check the amp draw on each of the three phases to the heater. All should match the FLA listed for the heater on the unit nameplate. Replace the heater contactor if there is a voltage imbalance greater than 10%. <i>See Section 6, Replacing the Heater Contactor.</i></p> <p>Increase the low deviation setting. The recommended setting is 2°F to 10°F.</p> <p>Review specifications and selection guidelines that apply to heater and pump sizes in temperature control units.</p> <p><i>See Section 5, Control Deviation Alarm/Inhibition Delay.</i></p>

The Thermolator has detected a problem that could lead to a problem if it is not corrected.

- ◆ The Thermolator continues operating.
- ◆ The control displays a red LED indicating the source of the problem.

TW-1, TW-2 CONTROL OTHER WARNINGS

Alarm	Possible cause	Solution
<p>● SPI Communication</p> <p>The SPI communication link has failed.</p>	The unit is not connected to a host machine.	If the Thermolator is not connected to a host device, set the SPI address to OFF using the Setpoint adjustment buttons on the control panel.
	The network address and baud rate are incorrect.	<input type="checkbox"/> Check the network address. The address may be set to any number from 32 to 254 (a hexadecimal integer between 20 and FE), as long as that number has not been assigned to another machine connected to the same network. <input type="checkbox"/> Make sure the baud rate (9600, 4800, 2400, or 1200) matches the host machine.
	Something is wrong with the cable.	Check the communication cable condition and connections. The cable must conform to SPI standards. Check for loose connections on the motherboard.
	If multiple units, the communication cycle is bogged down.	Remove 120 Termination resistor on Motherboard.
<p>SET tyP</p> <p>DIP Switch Error</p>	The controller type DIP switches (7 and 8) inadvertently changed since the last power up sequence.	Power down the controller and reset the controller type DIP switches (7 and 8) to the previous settings. <i>Refer to TW-1, TW-2 Control Initial Setup, Section 3 for details on the proper DIP switch settings.</i>
	If Motherboard was replaced and dipswitch 7 and 8 correct.	Press Run and Stop simultaneously to acknowledge dip-switch change.

TW-1, TW-2 CONTROL SYSTEM ALARMS

The Thermolator has detected a non-recoverable error involving the microprocessor control.

- ◆ The Alarm LED lights and the STOP/RUN LED flashes red.
- ◆ The Thermolator shuts down or will not start.
- ◆ The control displays an error code indicating the source of the problem.

Note: Press stop to clear any of these alarms. Cycle power if alarm does not clear.

Alarm	Cause	Solution
ERR 001 RAM hardware failure.	Electrical noise or failed CPU on the motherboard caused system write tests to fail during power up.	Make sure all connections on the motherboard are solid. Operate unit in a noise free environment. If error persists, replace Motherboard.
ERR 002 ROM, checksum failure.	The CPU and/or PROM chip (U1 or U2) is not making good contact with its socket, or the PROM chip has failed.	Make sure the CPU and PROM chips are seated correctly in the sockets. If error persists, replace Motherboard.
ERR 003 ERR 004 COP failures.	A failed CPU, failed motherboard, software bug or electrical noise caused an internal software error	Cycle power to the unit. If the problem persists, replace Motherboard.
ERR 005 Illegal Opcode	The CPU tried to execute an illegal software instruction due to electrical noise or a failed motherboard.	Make sure all connections to the motherboard are solid and that the unit is operating in a noise free environment. If error persists, replace Motherboard.
ERR 006 through ERR 014	A failed CPU, failed motherboard, software bug or electrical noise caused an internal software error.	Cycle power to the unit. If the problem persists, replace Motherboard.
ERR 015 ERR 016 Software cannot write to CPU non-volatile memory.	The memory has exceeded its usable life or there is a software bug. This error occurs only after changes have been made to non-volatile memory either through the operator panel or SPI.	Cycle power to the unit. Replace Motherboard.

If you apply power to the Thermolator and the control panel does not light, you have a problem with the main power circuit or the unit's microprocessor board.



WARNING: Electrical Shock Hazard
Disconnect and lockout the main power supply before proceeding.

THERMOLATOR WILL NOT POWER UP

Symptom	Possible cause	Solution
Applying power does not turn on the Thermolator or light the control panel.	Power is not reaching the Thermolator	<input type="checkbox"/> Verify that the main power supply and any customer-installed electrical disconnect or emergency stop devices are in the ON position. <input type="checkbox"/> Verify correct electrical connections between the Motherboard and the control operator panel, and between the unit's transformer and the power input to the Motherboard. Replace any damaged wires or cables.
	120V present to motherboard (TW1 ,2) Fuse 1	Check cable connection from operator panel to motherboard. Swap operator panel with another like unit to test.
	TW Plus-blank display	Check transformer fuse and control wiring from terminal block strip to control harness plug. See electrical drawings for power wiring.
	The unit has blown a fuse.	Check Fuse 1 on the motherboard and any fuses or breakers associated with customer-installed disconnect devices. Replace or reset as required. Identify the cause of the ground fault and correct it. See Section 6, <i>Checking and Replacing Fuses</i> .
The control panel is lit, but the Thermolator will not operate when RUN is pressed.	The incorrect voltage is reaching the Thermolator.	Check the electrical requirements on the unit nameplate. Verify correct main supply voltage to the unit and the secondary voltage supply from the transformer to unit components. Replace the transformer, if necessary.
	The unit is in Test Mode.	If the Test Mode LED is lit, you must disable Test Mode on the motherboard before resuming operation. See Section 5, <i>Performing System Tests</i> .
	The run or stop switch is defective.	See Section 5, <i>Performing System Tests</i> . Activate dsp to test button input.

REPLACING THE TW PLUS TEMPERATURE CONTROLLER

The temperature controller used in the Thermolator TW Plus slides in and out of its casing for easy replacement.

- 1** Disconnect and lockout the main power.
- 2** Unscrew the nuts and then remove the control metal.
- 3** Disconnect connectors on back of controllers.



- 4** Remove controller by squeezing plastic returning clip tabs. Pull out controller.

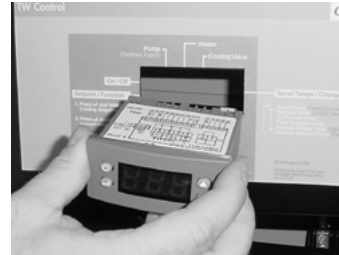

- 5** Reverse order to install new controller.
See Section 3, TW Plus control initial setup.

This procedure covers the factory-installed fuses on the TW1 and TW2 unit's motherboard. If you have installed an electrical disconnect or emergency stop switch, additional fuses and/or breakers may have been used elsewhere in the main power circuit.

To replace a blown fuse:

- 1** Disconnect and lockout the main power.
- 2** Open the electrical enclosure door.
Turn the screw on the front panel counterclockwise to open.
- 3** Replace the fuse. The fuses are located on the motherboard and are labeled and identified on the RFI shield.
Note: TW units have transformer fuses.
- 4** Close the electrical enclosure and restart the unit.

If fuse continues to fail:

- Verify that the unit is receiving the correct voltage.
Check the voltage, phasing and amperage ratings on the unit's nameplate.
- Verify that the unit's transformer is operating correctly.
Check for proper voltage (120V ±10%) to the voltage sensing device for the fuse location.
- Check all wiring referencing the fusing location for loose connections, damage or improper grounding.
Verify that the correct device is being used for this fuse location. See Section 5, *Disabling or Enabling Output Monitors*.

CHECKING AND REPLACING CONTROL POWER FUSES



WARNING:
Shock Hazard

Only qualified service personnel familiar with electrical testing and industrial equipment should examine and correct problems that require opening the unit with power on to diagnose the cause of a problem.

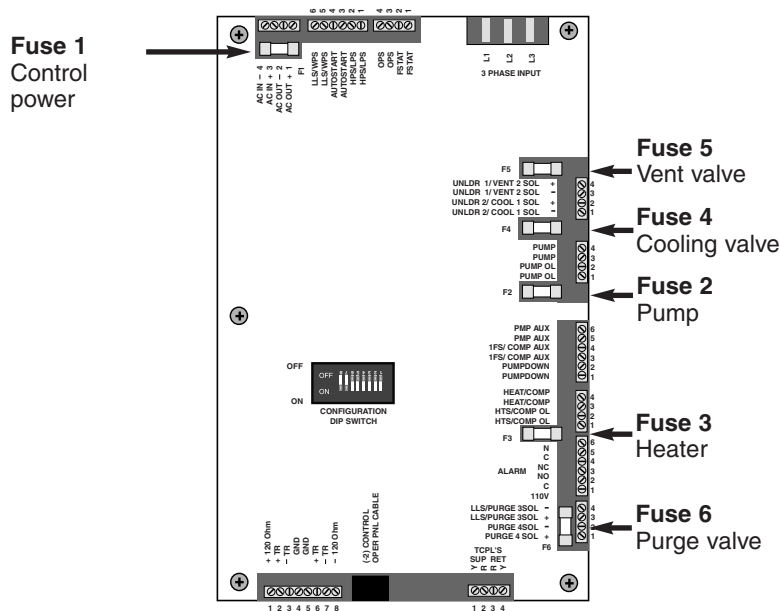

TW Plus Transformer fuses

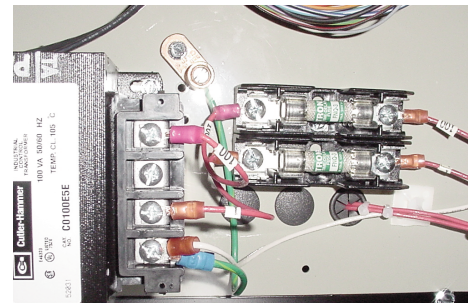

IMPORTANT: Always refer to the wiring diagrams that came with your Thermolator to locate specific electrical components. Illustrations in the User Guide are intended to be representative only.

RESETTING OVERLOADS

The pump motor overload is located inside the unit's electrical enclosure.

- 1 Disconnect and lockout the main power.**
- 2 Open the electrical enclosure door.** Turn the screw on the front panel counterclockwise to open.
- 3 Check the overload.**

If the red/yellow button is out, the overload has tripped. Press the blue button to reset the overload. Verify that the overload trip point does not exceed the FLA for the pump.

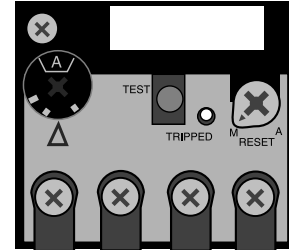

REPLACING PUMP OVERLOAD

- 1 Disconnect and lockout the main power.**
- 2 Open the electrical enclosure door.** Turn the screw on the front panel counterclockwise to open.
- 3 Locate the pump overload module attached to the pump motor starter.**
- 4 Disconnect the three power leads from the overload module to the pump motor.** Note the placement of each lead and label as needed.

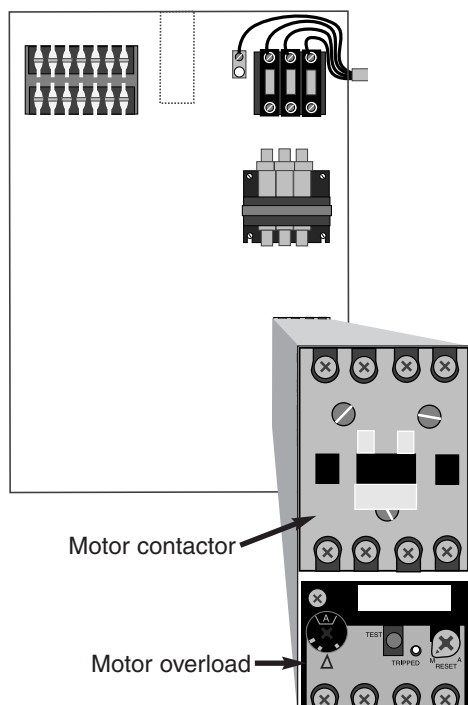

- 5 Disconnect auxiliary wiring on the overload module.**
- 6 Remove the overload module.** Loosen the three screws that connect the overload module to the motor contactor. Pull the overload module down to release it from the starter.
- 7 Reverse these steps to install the new overload module.**
- 8 Set the module reset mode to MAN (manual).**
- 9 Set the proper FLA trip point.** Do not exceed the SFA (service factor amps) for the pump motor.

REPLACING THE TW1 AND TW2 MOTHERBOARD

1 Disconnect and lockout the main power supply.

2 Open the electrical enclosure door.
Turn the screw on the front panel counterclockwise to open.

3 Mark or label each wire connected to the motherboard.
The RFI shield is labeled with the connection information. You must label the wires to ensure they are connected to the correct terminals on the new motherboard.

4 Disconnect the wires from the motherboard by pulling the terminal blocks up.

5 Loosen the screws holding the RFI shield.

6 Remove the motherboard and shield from the electrical enclosure as a unit.

7 Remove the motherboard from the shield and replace with the new motherboard.

8 Reattach the shield and new motherboard in the electrical enclosure.
Tighten the screws.

9 Reconnect the terminal blocks and wires to the new board. Make sure you align the terminal blocks with the correct pins on the board. Push the terminal blocks onto the pins, taking care not to bend or miss any pins.

10 Set dip switches 7 and 8 to the correct unit type.
Set ON for DI and CC models; set off for IC models.

11 Program output monitors on the new board.
See Section 5, Disabling or Enabling Output Monitors.

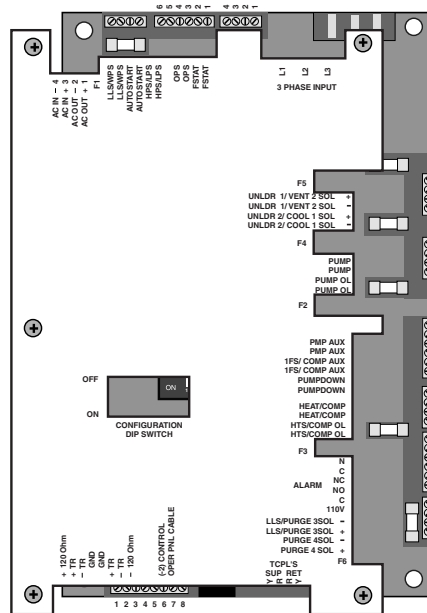
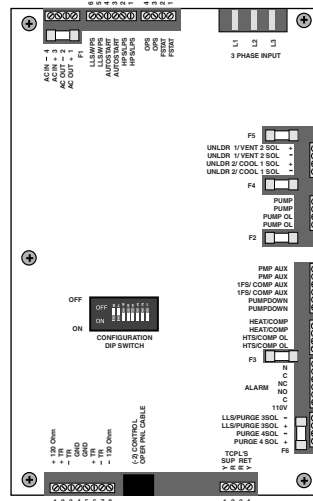

IMPORTANT: Always refer to the wiring diagrams that came with your Thermolator to locate specific electrical components. Illustrations in the User Guide are intended to be representative only.

NOTE: Follow instructions shipped with replacement Motherboard.

REPLACING THE HEATER CONTACTOR

IMPORTANT: Always refer to the wiring diagrams that came with your Thermolator to locate specific electrical components. Illustrations in the User Guide are intended to be representative only.



WARNING: Electrical Shock Hazard

Only qualified service personnel who have been trained on electrical testing and the procedures for avoiding the hazards should diagnose or correct problems that require opening the unit with power on.

Thermolators use mercury displacement heater contactors. The heater contactors should be replaced if you have checked:

- the amp draw on each of the three-phase legs and discovered a voltage imbalance greater than 10%.
- the continuity and found that ohms at the coil equal zero.

To replace the heater contactor:

- 1 Disconnect and lockout the main power.**
- 2 Open the electrical enclosure door.**
Turn the screw on the front panel counterclockwise to open.
- 3 Disconnect the wires from the heater contactor**
Make sure you label the wires to ensure you can connect them correctly to the new contactor.
- 4 Remove the contactor**
by removing the screws that hold it in place.
- 5 Discard old contactor**
using the proper disposal procedure. *See Material Safety Data Sheet, Appendix D-5.*
- 6 Reverse this procedure**
to install the new contactor.
Make sure the wires are connected correctly.

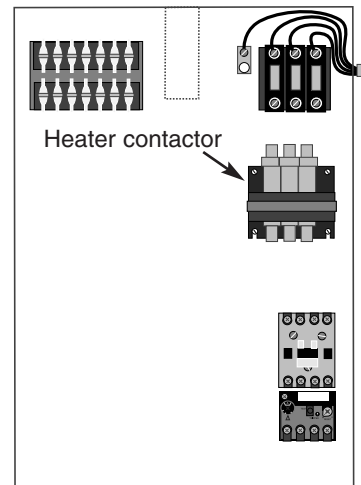

WARNING: Hazardous Substance

Thermolators use mercury displacement contactors. Mercury is considered a hazardous substance and must be dealt with accordingly. See the Material Safety Data for information on the how to avoid the potential hazards and how to clean up and dispose of mercury if it spills.

The Thermolator uses two type ‘K’ thermocouples to monitor supply and return process temperatures. One thermocouple is installed in the wall of the heater tank at the “to process” outlet. The other thermocouple is installed in the wall of the cooling tank at the “from process” inlet.

To check a thermocouple after a probe error:

- 1 Disconnect and lockout the main power.**
- 2 Open the electrical enclosure door.** Turn the screw on the front panel counterclockwise to open.
- 3 Unplug the appropriate thermocouple from the motherboard and install a jumper on the leads.** Refer to the wiring diagrams that came with your unit.
- 4 Restart the Thermolator.**
 - ◆ If error message disappears, replace the thermocouple.
 - ◆ If error message does not disappear, replace the motherboard. *See Section 6, Replacing the Motherboard.*

CHECKING THERMOCOUPLES TW-1 AND TW-2 CONTROLS

NOTE: With Jumpers in place ambient temperature should be displayed for reference temperature.

To replace a thermocouple/or PT1000 Sensors:

- 1 Disconnect and lockout the main power.**
- 2 Shut off the cooling water in and drain the unit.** Drain all water using the drain plugs located in the bottom of the unit.
- 3 Remove the unit’s top panel** and open the electrical enclosure.
- 4 Remove the thermocouple/sensor.** Loosen the compression nut to slide the thermocouple out of the casing. Disconnect the thermocouple wires at the motherboard.
- 5 Install the new thermocouple/sensor.** Insert the tip of the new thermocouple/sensor at least 1 inch into the tank. Carefully tighten the compression nut, making sure to not overtighten. Thread the leads through the raceway leading to the electrical enclosure. Attach the thermocouple leads to the motherboard or sensor to the terminal block.

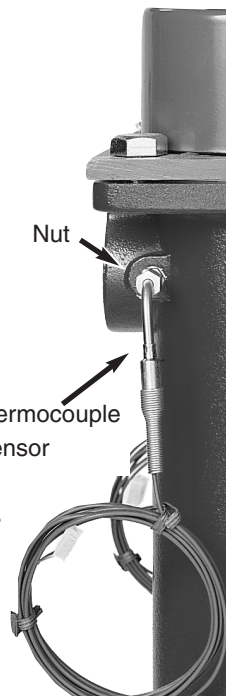

REPLACING THERMOCOUPLES/ OR PT1000 SENSORS

WARNING:
Hot surfaces
Allow the Thermolator to cool to below 100°F (38°C) before servicing the unit.

PT1000 SENSOR TEST READINGS TW PLUS CONTROL

If you receive a sensor failure SF2 a possible cause may be the process temperature sensor failed. Check with OHM meter and see if the resistance matches the table below. Replace if needed. In addition the sensor wiring may be incorrect or failed. If this is the case check all wiring from terminal strip to sensor in question. Repair as necessary.

Temperature Vs. Resistance readings

°F (°C)	Resistance in Ohms
20 (-7)	974
25 (-4)	985
30 (-1)	996
35 (-2)	1007
40 (4)	1017
45 (7)	1028
50 (10)	1039
55 (13)	1050
60 (15)	1061
65 (18)	1071
70 (21)	1082
75 (24)	1093
80 (27)	1103
85 (29)	1115
90 (32)	1125
95 (35)	1136
100 (38)	1146

REPAIRING COOLING VALVES

Every Thermolator has a cooling valve assembly that controls the cooling water out flow. Closed circuit (CC) units also have a vent valve assembly. Solenoid valves also are found on the optional purge valve.



WARNING: Electrical shock and hot surface hazards



Before attempting maintenance of any kind on the Thermolator, you must stop the unit; disconnect and lockout the main power supply; and allow the unit to cool to 100°F (38°C)

- 1 Disconnect and lock** out main power.

- 2 Shut off the cooling water in.**

- 3 Drain the unit of all water** through the relief valve port in the rear of the unit.

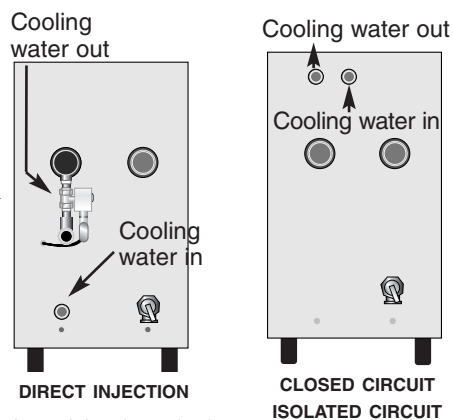

- 4 Remove the cooling water out feed.** For closed and isolated circuit models, also remove the cooling water in feed.

- 5 If vent valve is defective, remove the top and side panels** of the Thermolator. Lift the top panel straight up, then lift the side panels up.

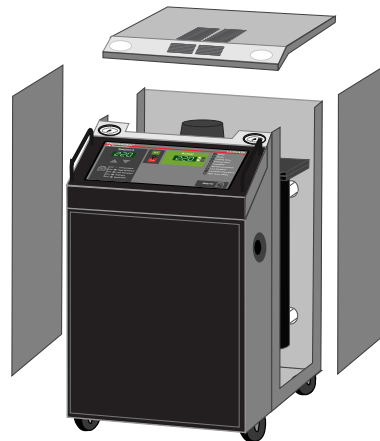

- 6 If replacing the Cooling valve,** remove the defective cooling, venting or purge valve, go to step 9.

- 7 Disassemble the cooling valve.**
See Section 6, Repairing Solenoid Valves and Repairing Modulating Valves.

- 8 Inspect and clean or repair the valve body** assembly. Remove foreign particles and replace damaged parts as necessary.

Continued

REPAIRING SOLENOID VALVES

CONTINUED

*Indicates Parts Supplied in Solenoid Enclosure Kit

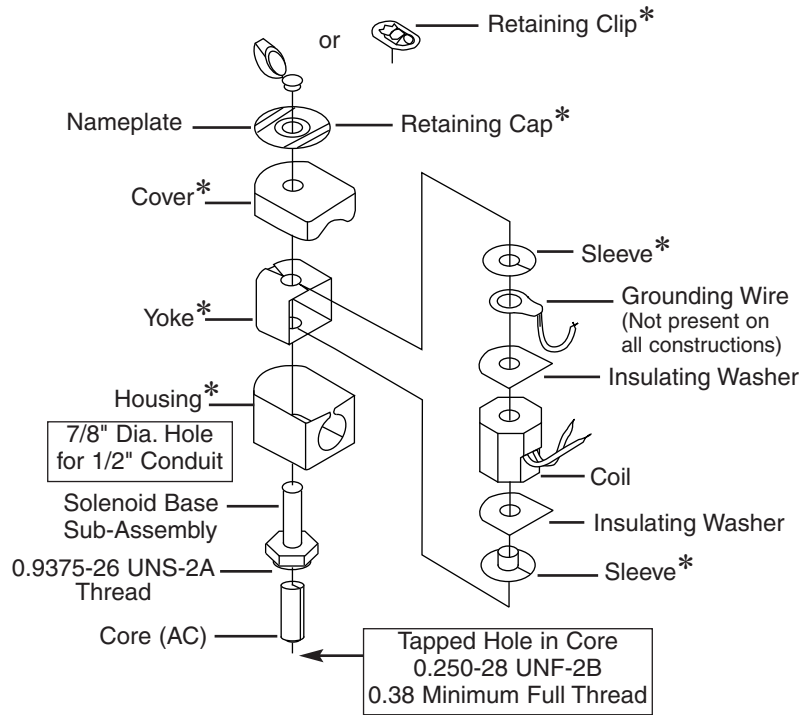

Alternate Construction with Nameplate on Housing

*Indicates Parts Supplied in Solenoid Enclosure Kit

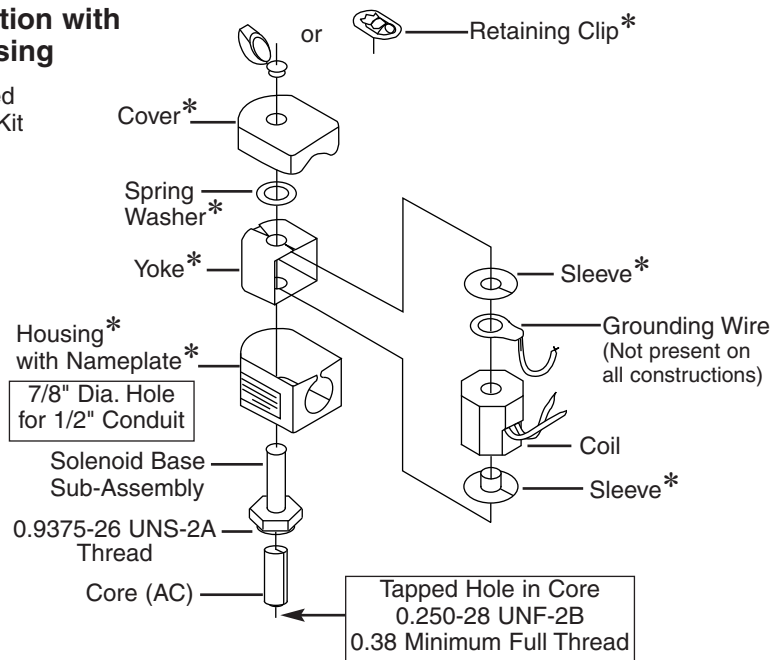

- 9** **Reassemble the valve and other components.** Reassemble in reverse order. Seal all pipe fittings with pipe sealant. Check that all flows are in the correct direction. Check for leaks before resuming operation.

Disassemble valves following the steps in **Repairing Cooling Valves**. Reassemble the valve and other components in reverse order of disassembly. Seal all pipe fittings with pipe sealant. Check that all flows are in the correct direction. Check for leaks before resuming operation.

REPAIRING OF MODULATING VALVES

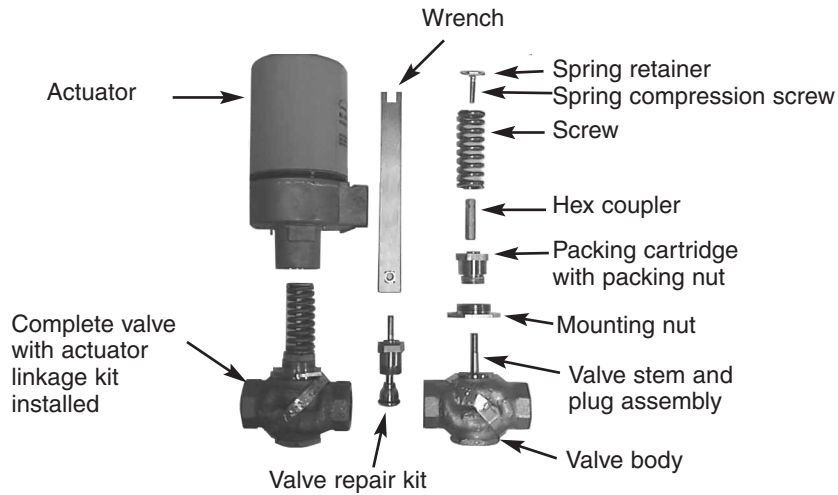

The Valve Repair kit includes Valve Stem and Plug Assembly and Packing Cartridge with Packing Nut.

REPLACING HEATER ELEMENTS



WARNING: Electrical shock and hot surface hazards

Before attempting maintenance of any kind on the Thermolator, you must stop the unit; disconnect and lockout the main power supply; and allow the unit to cool to less than 100°F (38°C)



- 1 Disconnect and lockout the main power.**
- 2 Remove the top panel of the Thermolator.**
- 3 Remove the heater cap.**

Use a 1/4-inch open-end wrench to remove the three bolts that hold the cap to the heater tank.

- 4 Remove the heater wiring harness.** Label the wiring layout of the heater terminals; wires are labeled 2T1, 2T2, 2T3 and GND. *See electrical schematic in binder folder.*

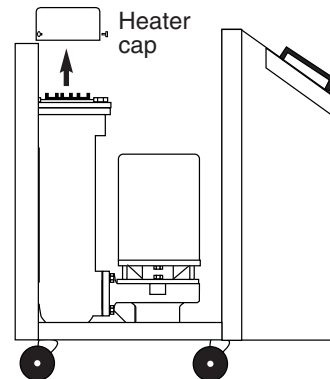

Continued

Unscrew the locking wire connector nut on the wiring harness and remove the wires.

- 5** Shut off the cooling water in feed.
- 6** Drain the Thermolator using the Relief valve or drain plugs located at the rear of the unit.
- 7** Remove the four bolts that hold the heater element in place. Use a 15/16-inch socket with 1/2-inch drive.
- 8** Lift the heating element out of the heater tube. Lift the element straight up.

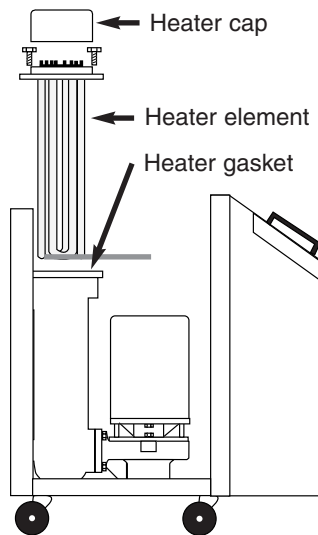

- 9** Replace the heater gasket if it is worn or dried out.
- 10** Reverse these steps to install the new heater element and reassemble the unit.

REPLACING HEATER ELEMENTS

CONTINUED

IMPORTANT: Always refer to the wiring diagrams that came with your Thermolator to locate specific electrical components. Illustrations in the User Guide are intended to be representative only.

REMOVING THE PUMP



WARNING: Electrical shock and hot surface hazards

Before attempting maintenance of any kind on the Thermolator, you must stop the unit; disconnect and lockout the main power supply; and allow the unit to cool to less than 100°F (38°C)



1 Disconnect and lockout the main power.

2 Shut off the cooling water in feed.

3 Drain the unit of all water through the relief valve port in the rear of the unit.

4 Remove the top and side panels..

5 Remove the seal flush

line. Use a 1/2-inch open-end wrench to remove the flush line from the connection on the pump adapter.

6 Remove the pump assembly bolts and wiring. Use a 9/16-inch open-end wrench or socket to remove the bolts holding the pump to the volute. The bolt in the rear will require a 9/16-inch crows foot wrench.

7 Using a 1/4-inch to 1/2-inch wide thin tapered punch, tap/pry two opposite ends to evenly separate pump adapter from volute.

8 Lift the pump assembly straight up to remove. The pump can now be replaced or disassembled for repair. Extra long leads are provided so the motor can be removed without disconnecting the wires.

9 Reverse the steps to reassemble the unit.

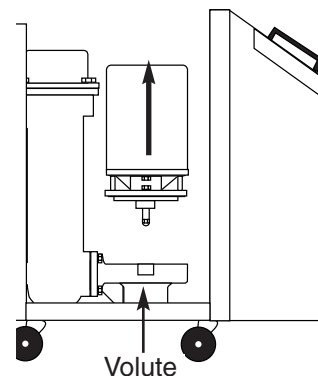
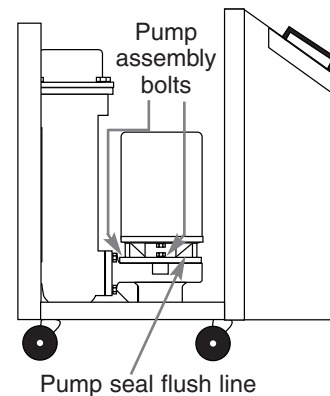
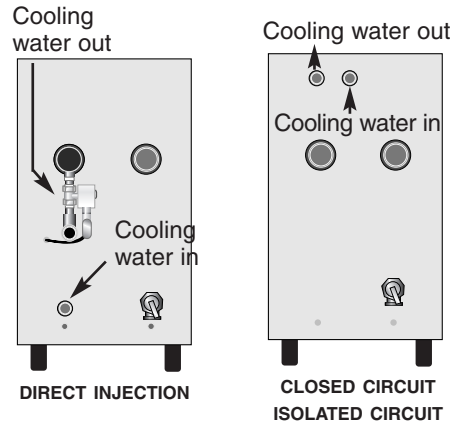

NOTE: Wire terminations. See motor data plate for wiring proper voltage.

NOTE: Before restarting, close all drain openings using sealant on the threads and reprime the pump. Do not start until the pump is completely filled with water.

DISASSEMBLING AND ASSEMBLING 3/4 - 2 HP PUMPS

To replace a failed seal, you must disassemble the pump.

- 1 Remove the impeller nut.**
Insert a screwdriver in one of the impeller waterway passages and back off the impeller nut.
- 2 Remove the impeller by inserting a screwdriver in the slot of the motor shaft.** Unscrew the impeller while holding the shaft against the rotation.
- 3 Remove the seal, gasket case, adapter and flinger.**

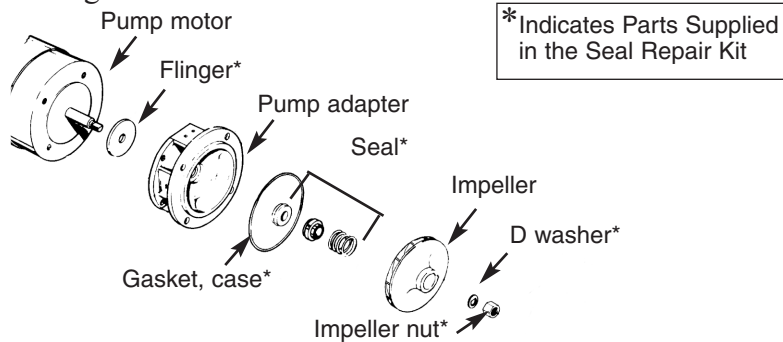

- 4 Clean the gasket and flange faces, seal seat cavity and shaft.** The shaft shoulder that fits against the impeller must be clean.
- 5 Replace the flinger.**
Lubricate the seal seat cavity of the adapter and the flinger with soapy water solution or supplied lubricant from the seal kit package before pressing the flinger squarely into the cavity. Do not chip or scratch the lapped seat face.
- 6 Remount the adapter to the motor, making** sure the motor shaft does not dislocate or chip the seat of the seal.
- 7 Replace the remaining seal components.**
Apply a soapy water solution or supplied lubricant from the seal kit package to the motor shaft and the rubber bellows of the rotating seal. Be sure the rotating seal face stays in the holding collar during installation. Do not chip or scratch the lapped seat faces.
- 8 Reassemble the remaining components, holding** the shaft against rotation. Remove any burrs caused by the screwdriver on the impeller.
- 9 Reattach the pump to the volute case.**
Replace any damaged gasket or O-ring between the pump assembly and volute case. Check for free rotation after assembly is completed.

NOTE: Before restarting, close all drain openings using sealant on the threads and refill the unit with fluid. Do not start the pump when the unit is dry.

DISASSEMBLING AND ASSEMBLING 3 - 7.5 HP PUMPS

To replace a failed seal, you must disassemble the pump.

- 1 Remove the impeller retaining assembly.** Insert a screwdriver in one of the impeller waterway passages to hold the impeller steady while removing the retainer.
- 2 Remove the impeller being careful not to lose any parts.** If the impeller is difficult to remove, you may need to use a bearing puller.
- 3 Remove the seal, adapter, shaft and flinger.**

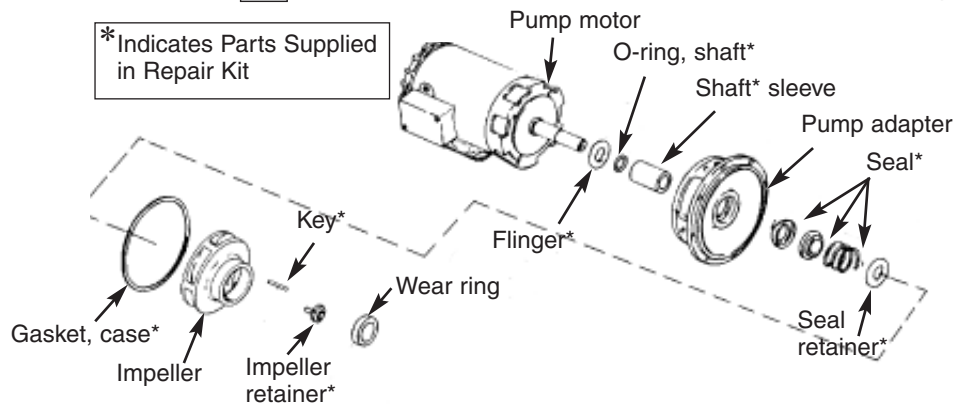

- 4 Clean the gasket and flange faces, seal seat cavity, shaft sleeve and motor shaft.** Replace the shaft sleeve if it is damaged or worn.
- 5 Replace the flinger.** Lubricate the seal seat cavity of the adapter and the flinger with soapy water solution or supplied lubricant from the seal kit package before pressing the flinger squarely into the cavity. Do not chip or scratch the lapped seat face.
- 6 Remount the adapter to the motor.** Make sure the motor shaft does not dislocate or chip the seat of the seal.
- 7 Replace the remaining seal components.** Apply a soapy water solution or supplied lubricant from the seal kit package to the motor shaft and the rubber bellows of the rotating seal. Slide the rotating member of the seal over the shaft sleeve. Replace the seal spring and seal retainer, making sure the rotating seal face stays in the holding collar during installation. Do not chip or scratch the lapped seat faces.
- 8 Place the key in the key seat and slide the impeller on the shaft.** Replace the impeller retaining bolt. Remove any burrs caused by the screwdriver on the impeller.

Continued

-
- 9** **Reattach the pump to the volute.** Make sure you replace any damaged gasket or O-ring between the pump assembly and volute case. Check for free rotation after assembly is completed.

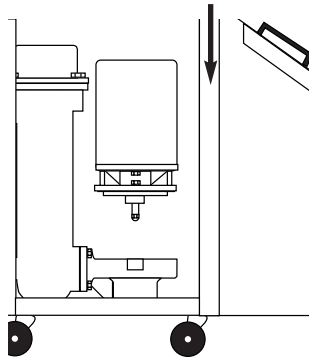

DISASSEMBLING AND ASSEMBLING 3 - 7.5 HP PUMPS CONTINUED

NOTE: Before restarting, close all drain openings using sealant on the threads and and refill the unit with fluid. Do not start the the pump when the unit is dry.

We're Here to Help

Conair has made the largest investment in customer support in the plastics industry. Our service experts are available to help with any problem you might have installing and operating your equipment. Your Conair sales representative also can help analyze the nature of your problem, assuring that it did not result from misapplication or improper use.

Additional manuals and prints for your Conair equipment may be ordered through the Customer Service or Parts Department for a nominal fee.

How to Contact Customer Service

To contact Customer Service personnel, call:



 **NOTE:** Normal operating hours are 8:00 am - 5:00 pm. After hours emergency service is available at the same phone number.

From outside the United States, call: 814-437-6861

You can commission Conair service personnel to provide on-site service by contacting the Customer Service Department.

Before You Call...

If you do have a problem, please complete the following checklist before calling Conair:

- Make sure you have all model, control type and serial numbers from the serial tag, and parts list numbers for your particular equipment. Service personnel will need this information to assist you..
- Make sure power is supplied to the equipment.
- Make sure that all connectors and wires within and between control systems and related components have been installed correctly.
- Check the troubleshooting guide of this manual for a solution.
- Thoroughly examine the instruction manual(s) for associated equipment, especially controls. Each manual may have its own troubleshooting guide to help you.
- Check that the equipment has been operated as described in this manual.
- Check accompanying schematic drawings for information on special considerations.

Equipment Guarantee

Conair guarantees the machinery and equipment on this order, for a period as defined in the quotation from date of shipment, against defects in material and workmanship under the normal use and service for which it was recommended (except for parts that are typically replaced after normal usage, such as filters, liner plates, etc.). Conair's guarantee is limited to replacing, at our option, the part or parts determined by us to be defective after examination. The customer assumes the cost of transportation of the part or parts to and from the factory.

Performance Warranty

Conair warrants that this equipment will perform at or above the ratings stated in specific quotations covering the equipment or as detailed in engineering specifications, provided the equipment is applied, installed, operated and maintained in the recommended manner as outlined in our quotation or specifications.

Should performance not meet warranted levels, Conair at its discretion will exercise one of the following options:

- Inspect the equipment and perform alterations or adjustments to satisfy performance claims. (Charges for such inspections and corrections will be waived unless failure to meet warranty is due to misapplication, improper installation, poor maintenance practices or improper operation.)
- Replace the original equipment with other Conair equipment that will meet original performance claims at no extra cost to the customer.
- Refund the invoiced cost to the customer. Credit is subject to prior notice by the customer at which time a Return Goods Authorization Number (RGA) will be issued by Conair's Service Department. Returned equipment must be well crated and in proper operating condition, including all parts. Returns must be prepaid.

Purchaser must notify Conair in writing of any claim and provide a customer receipt and other evidence that a claim is being made.

Warranty Limitations

Except for the Equipment Guarantee and Performance Warranty stated above, Conair disclaims all other warranties with respect to the equipment, express or implied, arising by operation of law, course of dealing, usage of trade or otherwise, including but not limited to the implied warranties of merchantability and fitness for a particular purpose.

PUMP CURVES

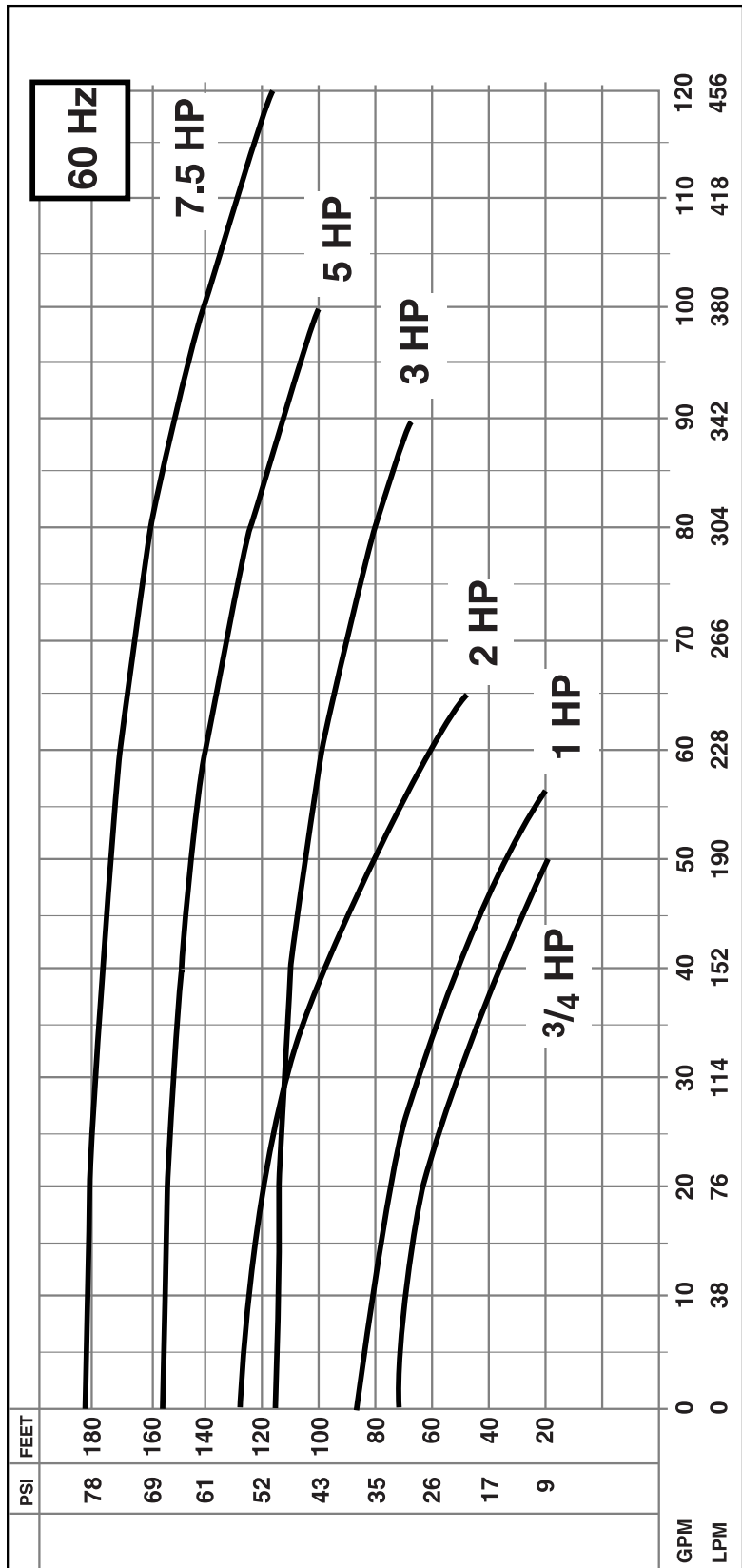

The Thermolator will not operate correctly if certain factory-set parameters are changed. Parameters should be changed only by qualified technical personnel who are familiar with the operation of this type of equipment.

If the Thermolator does not appear to be working correctly, verify the parameters against the list of factory settings.

For more detailed information about these parameters and returning parameters to the initial factory setup, *See TW Plus initial setup, Section 3.*

TW PLUS CONTROL DEFAULT PARAMETERS

Menu	Function	Range	Default
User Level (1 sec)			
SET	Setpoint	20-250°F (-6.6-121.5°C)	75°F
ASP	Active Setpoint	Read Only	°F
Configuration Level (5 sec)			
Uni	Unit of Measure	°F or °C	°F
PUr	Process Variable	to = To Temperature	AUG
		Fro = From Temperature	
		AUG = Average Temperature	
		rE = Remote Temperature	
Pit	Proportional Integral Tuning	SLO = Slow	nor
		nor = Normal	
		FSt = Fast	
dSP	Deviation from Setpoint	0-45°F (0-25°C)	20°F
ddt	Deviation Alarm Delay Time Period	0-600 seconds	600 seconds
Ut1	Vent Time Period 1	0-999 seconds	15 seconds
Ut2	Vent Time Period 2	0-999 seconds	15 seconds
AAAt	Alarm Acknowledge Timer	0-60 minutes	1 minute
t01	Thermolator Version Release 01	Read Only	t02
Service Level (15 sec)			
SLo	Slow Proportional Prop Band	0.2-180°F (0.1-100°C)	2°F
nor	Normal Proportional Prop Band	0.2-180°F (0.1-100°C)	10°F
FSt	Fast Proportional Prop Band	0.2-180°F (0.1-100°C)	15°F
db	Dead Band	0-10°F (0-5.6°C)	0.5°F
CCt	Cooling Cycle Time	0-60 seconds	7 seconds
Ci	Cooling Integral Time Period	0-999 seconds	15 seconds
HCT	Heating Cycle Time	0-60 seconds	7 seconds
Hi	Heating Integral Time Period	0-999 seconds	15 seconds
PrS	Power-Up Restart Selector	on = Manual oFF = Auto	on
rSS	Remote Setpoint Selector	oFF = Controller Setpoint Active on = Remote Setpoint Active	OFF
PiC	Proportional to Integral Crossover Percent	0-100%	35%

The SPI commands supported by Conair Thermolator® mold temperature controllers are listed in the following tables.

The standard required commands and three optional commands are listed in the SPI Command Pairs table, along with the Select and Poll command pairs in hexadecimal format. Select commands set or change Thermolator functions. Poll commands retrieve information from the Thermolator.

TW-1, TW-2 CONTROLS SPI COMMANDS SUPPORTED BY THE CONAIR THERMOLATOR®

SPI Command Pairs		
Mold temperature controllers		Device ID: hex 20
Commands	Select	Poll
Echo - Select stores 4 bytes of information at the Thermolator; Poll retrieves it.	0x20 0x21	0x20 0x20
Version - Retrieves 4 bytes of SPI version information.		0x20 0x22
Setpoint Process Temperature - Sets and retrieves the process temperature setpoint.	0x20 0x31	0x20 0x30
Alarm, High Temperature Deviation* - Sets the alarm band temperature; retrieves setpoint + alarm band value.	0x20 0x33	0x20 0x32
Alarm, Low Temperature Deviation* - Sets the alarm band temperature; retrieves setpoint + alarm band value.	0x20 0x35	0x20 0x34
Process Status - Retrieves run status and alarm conditions.		0x20 0x40
Status, Machine 1 - Retrieves run status and alarm conditions.		0x20 0x42
Status, Machine 2 - Retrieves run status and alarm conditions.		0x20 0x44
Mode, Machine - Start/stops the Thermolator; acknowledges alarms; retrieves run status	0x20 0x49	0x20 0x48
Temperature, to Process - Retrieves the actual temperature of fluid leaving to the Thermolator.		0x20 0x70
Temperature, from Process - Retrieves the actual temperature of fluid returning to the Thermolator.		0x20 0x72
* NOTE: Both High and Low Temperature Deviation commands set the same variable. Use only one of these commands to avoid problems.		

See *SPI STATUS WORDS* for status words and BIT positions for Process Status, Machine 1 Status and Machine 2 status.

For more information on the SPI protocol, you can obtain the SPI Communication Protocol Manual by contacting:

The Society of the Plastics Industry, Inc.
1801 K Street, NW
Suite 600K
Washington DC 20006
(202) 974-5200 Fax: (202) 296-7005
www.plasticsindustry.org

TW-1, TW-2 CONTROL SPI STATUS WORDS

Status, Process																
Poll: 0x20 0x40																
SPI STATUS WORD	Open	Open	Reserved	Reserved	Reserved	Reserved	Alarm, Low flow	Reserved	Alarm, Low pressure condition	Alarm, High pressure condition	Alarm, Low temperature deviation	Alarm, High temperature deviation	Alarm, Machine	Alarm, Process	Alarm, System	Processing
Word BIT position	15	14	13	12	11	10	9	8	7	6	5	4	3	2	1	0
EEprom error														SET	SET	*
A/D converter error														SET	SET	*
CJC Error														SET	SET	*
RAM hardware														SET	SET	*
ROM checksum														SET	SET	*
Probe Failure													SET		SET	*
E/M Hi temp safety																*
Prog. Hi temp safety																*
Output monitor failure													SET		SET	*
Low water pressure									SET				SET		SET	*
High deviation alarm												SET		SET	SET	*
Low deviation alarm											SET			SET	SET	*
Prog. Lo temp safety																*
Pump overload													SET		SET	*
Low water level													SET		SET	*
Test Mode																*
Phase error																*

NOTES:

* The SPI I/O list defines the Processing bit as being cleared if the unit is not processing; otherwise it is SET.

Elsewhere on the chart:

- If a bit is not shown to be SET, it is cleared.
- The System Alarm bit is SET if an alarm is present. It is the logical OR of Process alarm and Machine alarm.
- Processing, System Alarm, Process Alarm and Machine Alarm bits are repeated for Process Status, Machine 1 Status and Machine 2 Status.

TW-1, TW-2 CONTROL SPI STATUS WORDS

Status, Machine 1																	
Poll: 0x20 0x42																	
SPI STATUS WORD	Open	Alarm, Phase	Alarm, Low current	Alarm, High current	Alarm, Low volts	Alarm, High volts	Reserved	Reserved	Alarm, Low pressure safety limit	Alarm, High pressure safety limit	Alarm, Low temperature safety limit	Alarm, High temperature safety limit	Alarm, Machine	Alarm, Process	Alarm, System	Processing	
	Word BIT position	15	14	13	12	11	10	9	8	7	6	5	4	3	2	1	0
EEprom error															SET	SET	*
A/D converter error															SET	SET	*
CJC Error															SET	SET	*
RAM hardware															SET	SET	*
ROM checksum															SET	SET	*
Probe Failure																	*
E/M Hi temp safety												SET	SET		SET		*
Prog. Hi temp safety												SET		SET	SET		*
Output monitor failure													SET		SET		*
Low water pressure									SET				SET		SET		*
High deviation alarm																	*
Low deviation alarm																	*
Prog. Lo temp safety												SET		SET	SET		*
Pump overload													SET		SET		*
Low water flow													SET		SET		*
Low water level													SET		SET		*
Test Mode																	*
Phase error		SET											SET		SET		*

NOTES:

- * The SPI I/O list defines the Processing bit as being cleared if the unit is not processing; otherwise it is SET.

Elsewhere on the chart:

- If a bit is not shown to be SET, it is cleared.
- The System Alarm bit is SET if an alarm is present. It is the logical OR of Process alarm and Machine alarm.
- Processing, System Alarm, Process Alarm and Machine Alarm bits are repeated for Process Status, Machine 1 Status and Machine 2 Status.

TW-1, TW-2 CONTROL SPI STATUS WORDS

Status, Machine 2

Poll: 0x20 0x44

SPI STATUS WORD	Open	Open	Reserved	Reserved	Reserved	Reserved	Reserved	Reserved	Reserved	Reserved	Reserved	Fault, CAL	Fault, Sensor	Alarm, Machine	Alarm, Process	Alarm, System	Processing
	15	14	13	12	11	10	9	8	7	6	5	4	3	2	1	0	
EEprom error															SET	SET	*
A/D converter error															SET	SET	*
CJC Error															SET	SET	*
RAM hardware															SET	SET	*
ROM checksum															SET	SET	*
Probe Failure													SET		SET	SET	*
E/M Hi temp safety																	*
Prog. Hi temp safety																	*
Output monitor failure														SET		SET	*
Low water pressure																	*
High deviation alarm																	*
Low deviation alarm																	*
Prog. Lo temp safety																	*
Pump overload														SET		SET	*
Low water level														SET		SET	*
Test Mode																	*
Phase error																	*

NOTES:

* The SPI I/O list defines the Processing bit as being cleared if the unit is not processing; otherwise it is SET.

Elsewhere on the chart:

- If a bit is not shown to be SET, it is cleared.
- The System Alarm bit is SET if an alarm is present. It is the logical OR of Process alarm and Machine alarm.
- Processing, System Alarm, Process Alarm and Machine Alarm bits are repeated for Process Status, Machine 1 Status and Machine 2 Status.

PARTS/DIAGRAMS

- *TW-1 Circuit BoardPD-2*
- *TW-2 Circuit BoardPD-3*

