

USER GUIDE  
UGC080-1218

# PowerFill

## PF-8 Series

### Pump, Dust Collector, Conveying Control



Please record your equipment's model and serial number(s) and the date you received it in the spaces provided.

It's a good idea to record the model and serial number(s) of your equipment and the date you received it in the User Guide. Our service department uses this information, along with the manual number, to provide help for the specific equipment you installed.

Please keep this User Guide and all manuals, engineering prints, and parts lists together for documentation of your equipment.

Date:

---

Manual Number: UGC080-1218

---

Serial Number(s):

---

Model Number(s):

---

**DISCLAIMER:** Conair shall not be liable for errors contained in this User Guide or for incidental, consequential damages in connection with the furnishing, performance or use of this information. Conair makes no warranty of any kind with regard to this information, including, but not limited to, the implied warranties of merchantability and fitness for a particular purpose.

# Table of Contents

## 1 - 1 Introduction

Purpose of the User Guide .....	1-2
How the Guide Is Organized.....	1-2
Your Responsibility as a User .....	1-2
ATTENTION: Read This So No One Gets Hurt .....	1-3

## 2 - 1 Description

What is the PowerFill? .....	2-2
Typical Applications.....	2-2
How it works .....	2-2
Specifications: .....	2-3

## 3 - 1 Installation

Unpacking the Boxes.....	3-2
Preparing for Installation .....	3-3
Installing the PowerFill .....	3-4
Motor Starter.....	3-5
Set-Up .....	3-6

## 4 - 1 Operation

Start-up .....	4-2
Single Loader Models.....	4-2
Ratio Models .....	4-3
Dual Loader Models .....	4-3
Power Fill A-B Control.....	4-4

## 5 - 1 Maintenance

Preventative Maintenance Schedule .....	5-2
Maintenance of the A-B Control .....	5-3

## **6 - 1** Troubleshooting

Before Beginning.....	6-2
A Few Words of Caution.....	6-2
Identifying the Cause of a Problem .....	6-3
Troubleshooting the A-B Control .....	6-6

## **A** Appendix

Customer Service Information .....	A-1
Warranty Information.....	A-2

# Introduction

---

Purpose of the User Guide ..... 1-2

How the Guide Is Organized ..... 1-2

Your Responsibility as a User ..... 1-2

ATTENTION: Read This So No One Gets Hurt..... 1-3

# Purpose of the User Guide

This User Guide describes the Conair PowerFill and explains step-by-step how to install, operate, maintain, and repair this equipment.

Before installing this product, please take a few moments to read the User Guide and review the diagrams and safety information in the instruction packet. You also should review manuals covering associated equipment in your system. This review won't take long, and it could save you valuable installation and operating time later.

# How the Guide is Organized

Symbols have been used to help organize the User Guide and call your attention to important information regarding safe installation and operation.



Symbols within triangles warn of conditions that could be hazardous to users or could damage equipment. Read and take precautions before proceeding.



Numbers indicate tasks or steps to be performed by the user.



A diamond indicates the equipment's response to an action performed by the user or a situation.



An open box marks items in a checklist.



A circle marks items in a list.



Indicates a tip. A tip is used to provide you with a suggestion that will help you with the maintenance and the operation of this equipment.



Indicates a note. A note is used to provide additional information about the steps you are following throughout the manual.

# Your Responsibility as a User

You must be familiar with all safety procedures concerning installation, operation, and maintenance of this equipment. Responsible safety procedures include:

- Thorough view of this User Guide, paying particular attention to hazard warnings, appendices, and related diagrams.
- Thorough review of the equipment itself, with careful attention to voltage sources, intended use, and warning labels.
- Thorough review of instruction manuals for associated equipment.
- Step-by-step adherence to instructions outlined in this User Guide.

# ATTENTION: Read This So No One Gets Hurt

We design equipment with the user's safety in mind. You can avoid the potential hazards identified on this machine by following the procedures outlined below and elsewhere in the User Guide.



**WARNING: Improper installation, operation, or servicing may result in equipment damage or personal injury.**



This equipment should be installed, adjusted, and serviced by qualified technical personnel who are familiar with the construction, operation, and potential hazards of this type of machine.

All wiring, disconnects, and fuses should be installed by qualified electrical technicians in accordance with electrical codes in your region. Always maintain a safe ground. Do not operate the equipment at power levels other than what is specified on the machine serial tag and data plate.



**WARNING: Voltage hazard**



This equipment is powered by three-phase main voltage, as specified on the machine serial tag and data plate.

A properly sized conductive ground wire from the incoming power supply must be connected to the chassis ground terminal inside the electrical enclosure. Improper grounding can result in severe personal injury and erratic machine operation.

Always disconnect and lock out the incoming main power source before opening the electrical enclosure or performing non-standard operating procedures, such as routine maintenance. Only qualified personnel should perform troubleshooting procedures that require access to the electrical enclosure while power is on.



**WARNING: Disconnect power and air sources**

Always disconnect the main power source and compressed air source before installing or servicing this equipment. This prevents the equipment from starting during servicing, which could cause personal injury from flying debris or moving parts, or could cause equipment damage.



# Description

---

What is the PowerFill? ..... 2-2

Typical Applications ..... 2-2

How it works ..... 2-2

Specifications: ..... 2-3

# What is the PowerFill?

The PowerFill PF-8 is a combination three-phase vacuum pump, miniature dust collector and control package designed to provide plastic processors with dependable vacuum power for the conveying of resins and regrinds. The PowerFill may be formatted to control up to eight loaders in either “single tube” (single material) or ratio (two material) operation. The PowerFill is designed to be coupled to Conair receivers and provide the control signals and vacuum power to allow efficient resin movement.

## Typical Applications

- One to eight machine installations
- Two-stage loading; from gaylord to hopper, hopper to machine
- Continuous filling of a gaylord or surge bin
- Loading a high throughput machine
- Central vacuum power for small manufacturing cells
- Eliminating noisy, high maintenance vacuum motors on loaders

## How it works

The PowerFill works like a typical conveying system, with the difference being that the PowerFill is an all-in-one compact small system. The PowerFill control is a combination of a peripheral vacuum pump (with gauge), a dust collector (41ft2 cartridge filter), and control for up to eight receivers (Conair Access Receiver, DuraLoad, Powder Receiver, FilterLess receiver, TLR Tube Loader, or Medical Receivers in a small, mobile package.

The PowerFill PLC and HMI can operate a full range of loading functions, including:

- Single material and/or ratio loading
- Gravity discharge valve
- Positive discharge valve
- Material line purging
- Volume or timed-fill loading

Standard I/O includes:

- Demand ratio valve
- Positive discharge valve
- Purge valve
- Fill sensor
- Remote demand sensor

# Specifications:

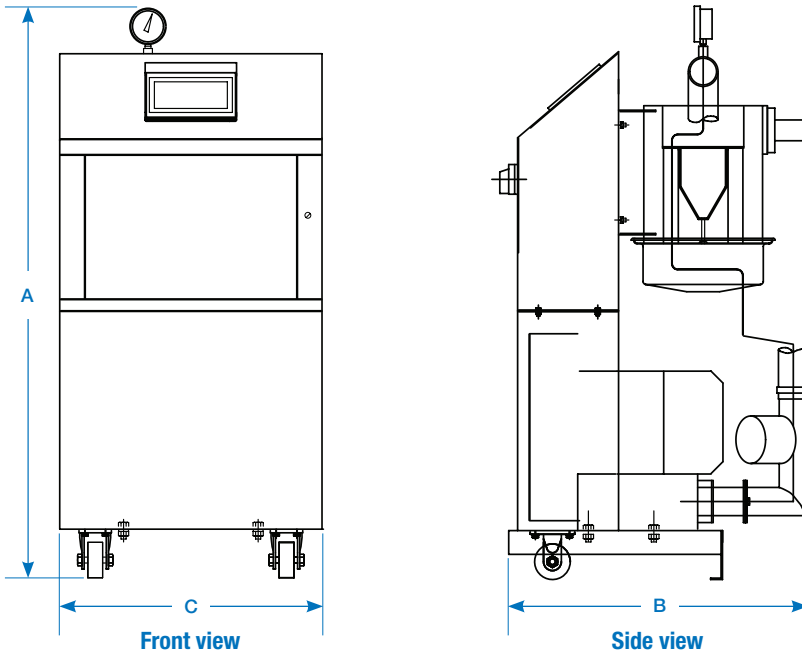

## Features

- Three-phase peripheral vacuum pump with gauge
- Multiple optional cable lengths available: 10 foot {3.04 m}, 20 foot {6.09 m}, 50 foot {15.24 m}, 100 foot {30.48 m}, 150 foot {45.72 m}
  - \* Cables are end to end compatible and can be extended. 20 + 50 feet {6.09 + 15.24 m} = 70 foot {21.33 m} total length.
- 41ft<sup>2</sup> cartridge filter
- Dust collection chamber with no-tools access for easy cleaning
- Tilt-back casters and handles
- Fully featured with I/O for any Conair receiver

Description 2

## Applications

- Up to eight receivers
- Works with Access Receiver (AR), DuraLoad (DL), Powder Receiver (PR), FilterLess (FL), Tube Loader (TLR), Medical Receivers (MR)
- Central vacuum power for small manufacturing cells
- Eliminating noisy, high maintenance vacuum motors on loaders

Model	PF8-3	PF8-4	PF8-6
<b>Performance characteristics</b>			
Maximum throughput lb {kg} per hour	900 {408}	1300 {590}	3200 {1452}
Motor Hp {kW}	2.33 {1.75}	3.6 {2.7}	6.16 {4.6}
Vacuum/material line sizes inches {mm}	1.5	1.75	2.25
Maximum tubing length ft {m}	100 {30.5}	175 {53.3}	225 {68.6}
<b>Dimensions inches {mm}</b>			
A - Height		49 {1245}	
B - Depth		28 {711}	
C - Width		23 {584}	
<b>Approximate weight lb {kg}</b>			
Installed	285 {129}		300 {136}
Shipping	385 {175}		400 {181}
<b>Filter</b>			
Filter type	Paper cartridge filter		
Number of filters	1		
Total filter area ft <sup>2</sup> {m <sup>2</sup> }	41 {3.8}		
<b>Voltage Full load amps *</b>			
208V / 3 phase / 60 Hz	7.2	10.6	19.5
240V / 3 phase / 60 Hz	6.6	10.2	17.6
380V / 3 phase / 50 Hz	5.2	5.9	8.3
415V / 3 phase / 50 Hz	5.1	5.6	7.8
480V / 3 phase / 60 Hz	3.3	5.1	8.8
575V / 3 phase / 60 Hz	2.7	3.3	7.0

### Application Notes

If conveyed materials exceed 200° F {93°C}, an aftercooler may be required on the incoming vacuum line.

The PowerFill dust collector may be supplemented with a higher capacity dust collector if excessive material dust is anticipated. (Cyclone Dust Collector or DC1 Dust Collector)

Rigid tubing is recommended for longer vacuum and/or material lines.

### Specification Notes

\* FLA data for reference purposes only. Does not include any options or accessories on equipment. For full FLA detail for power circuit design of specific machines and systems, refer to the electrical diagrams of the equipment order and the nameplate applied to the machine.

Specifications can change without notice. Contact a Conair representative for the most current information.



# Installation

---

Unpacking the Boxes .....	3-2
Preparing for Installation .....	3-3
Installing the PowerFill .....	3-4
Motor Starter.....	3-5
Set-Up .....	3-6

# Unpacking the Boxes

The PowerFill comes on a skid, with one or more boxes, depending on options ordered. The unit includes a touch screen interface and other options as ordered:



## **CAUTION: Lifting**

To avoid personal injury or damage to the PowerFill, lift the equipment out of the box carefully. A second person may be helpful in removing equipment from the box(es).

- 1 Carefully remove the PowerFill components from their shipping containers.**
- 2 Remove all packing material**, protective paper, tape, and plastic. Compare contents to the shipping papers to ensure that you have all the parts.
- 3 Carefully inspect all components** to make sure no damage occurred during shipping. Check all wire terminal connections, bolts, and any other electrical connections, which may have come loose during shipping.
- 4 Record serial numbers and specifications** in the blanks provided on the back of the User Guide's title page. This information will be helpful if you ever need service or parts.
- 5 You are now ready to begin installation.** *See Installation Section entitled, [Preparing for Installation](#).*

## Preparing for Installation

The PowerFill is designed to operate from a three-phase electrical source connected through the electrical disconnect switch within the main control enclosure. Check the PowerFill's ID tag for the correct voltage and be sure to install the power connection in compliance with all local and industrial electrical codes.

The inlet to the PowerFill's integrated Dust Collector must be connected via flex hose to the vacuum inlet(s) of the loader(s) to be powered by the PowerFill. In a multiple loader installation, this connection must be made through a vacuum "manifold" which splits the vacuum to the two loaders in the system. The vacuum valves of each loader will then work with the sequencing controls of the PowerFill open and close each loader in response to the demand load signals of each.

Do not make any connections to the blower discharge outlet in normal open-loop systems. In closed-loop dry air systems, connect the blower exhaust outlet tube to dryer return air manifold system.



**WARNING: Improper installation, operation, or servicing may result in equipment damage or personal injury.**



This equipment should be installed, adjusted, and serviced by qualified technical personnel who are familiar with the construction, operation, and potential hazards of this type of machine.

All wiring, disconnects, and fuses should be installed by qualified electrical technicians in accordance with electrical codes in your region. Always maintain a safe ground. Do not operate the equipment at power levels other than what is specified on the machine serial tag and data plate.

# Installing the PowerFill



## CAUTION:



Always disconnect and lock out the main power sources before making electrical connections. Electrical connections should be made only by qualified personnel.

**IMPORTANT:** Always refer to the wiring diagrams that came with your PowerFill to locate specific electrical components. Illustrations in the User Guide are intended to be representative only.

The control is in an enclosure that is easy to move to any conveying station. The small footprint preserves valuable floor space and makes the PowerFill easier to move. Just tilt the unit, wheel it into place, and connect it to a three-phase power source. Snap together cables and complete the necessary flex hose connections to vacuum receivers.

# Wiring Considerations



**WARNING: Improper installation, operation, or servicing may result in equipment damage or personal injury.**



This equipment should be installed, adjusted, and serviced by qualified technical personnel who are familiar with the construction, operation, and potential hazards of this type of machine.

All wiring, disconnects, and fuses should be installed by qualified electrical technicians in accordance with electrical codes in your region. Always maintain a safe ground. Do not operate the equipment at power levels other than what is specified on the machine serial tag and data plate.

Conair's sales number is  
724-584-5500.  
Conair's Instant Access 24/7 Parts and  
Service number is  
800-458-1960.  
Outside the U.S., dial  
814-437-6861.

## Motor Starter:

The pump is furnished with a full voltage type motor starter which is wired to the pump motor. Three phase-50 or 60 Hz power must be supplied to the disconnect. (Refer to the Conair nameplate for model number and use the chart below to properly size wire to the starter).

Pumps can be supplied for 208, 240, 380-50 or 60 Hz, or 480 or 575 volt operation and voltage must be specified with order. Since units are wired at the factory for a specific voltage with appropriately sized starters and thermal overloads, be certain to check intended voltage before connecting to plant power source.

All pumps are equipped with a factory preset, vacuum relief valve to avoid motor ampage overload - See chart below.

Pump Model	Max. Vacuum (In. Hg.)		Max. Amps.				
	Hg	H <sub>2</sub> O	208	240	380-50/60 Hz	480	575
P-3	5.2	71	6.7	6.1	3.5	3.1	2.3
P-4	6.0	81	9.1	8.2	6.5	4.8	3.3
P-6	9.6	130	18.5	15.8	8.3	7.9	4.6

Refer to motor name plate for max. amp ratings for other voltages.

## Setup:

**IMPORTANT:** Always refer to the wiring diagrams that came with your PowerFill to locate specific electrical components. Illustrations in the User Guide are intended to be representative only.

The multi-conductor control cable(s) coming from the PowerFill control enclosure must be connected to the appropriate loader(s) to supply the proper exchange of signals between the control and the loader.

Compressed air, if required, must be connected directly to the loaders used with the PowerFill per their individual instructions. In addition, the material conveying line should be connected directly to the loader via flex hose.

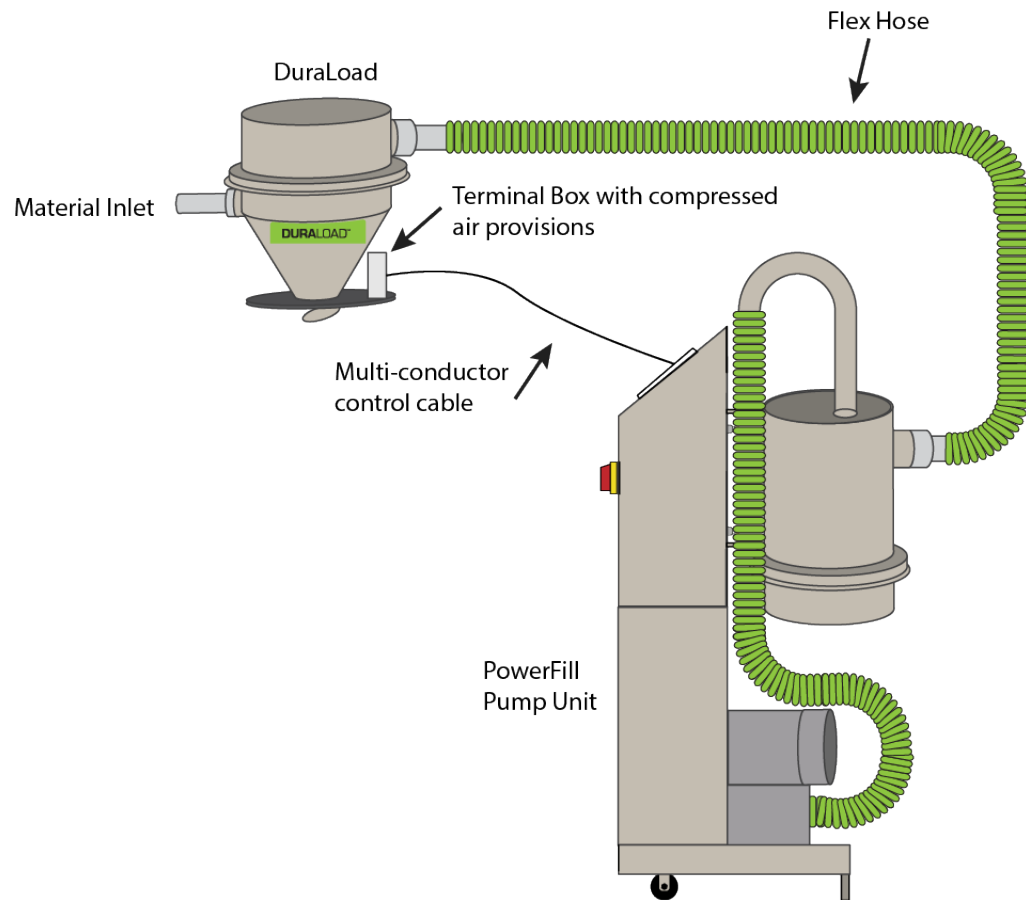

*Figure 1A*  
PowerFill with Pellet Loader

## Setup:(Continued)

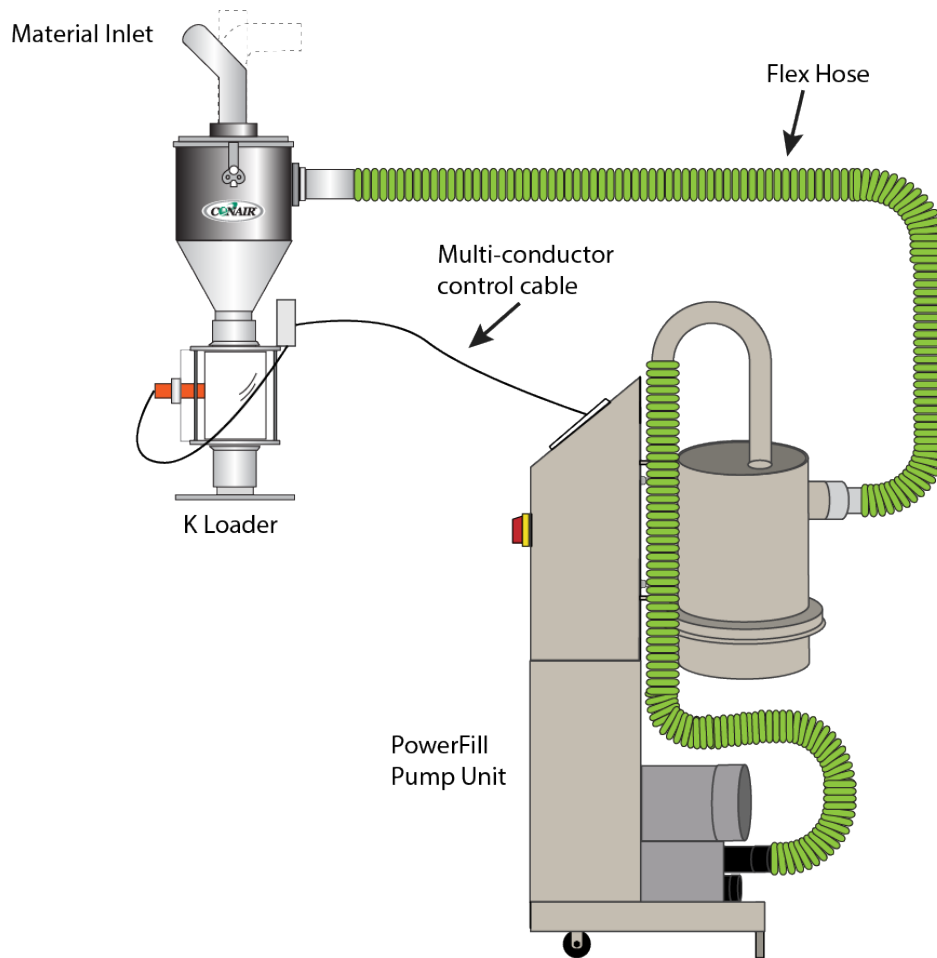

Figure 1B  
PowerFill with K Loader

## Setup:(Continued)

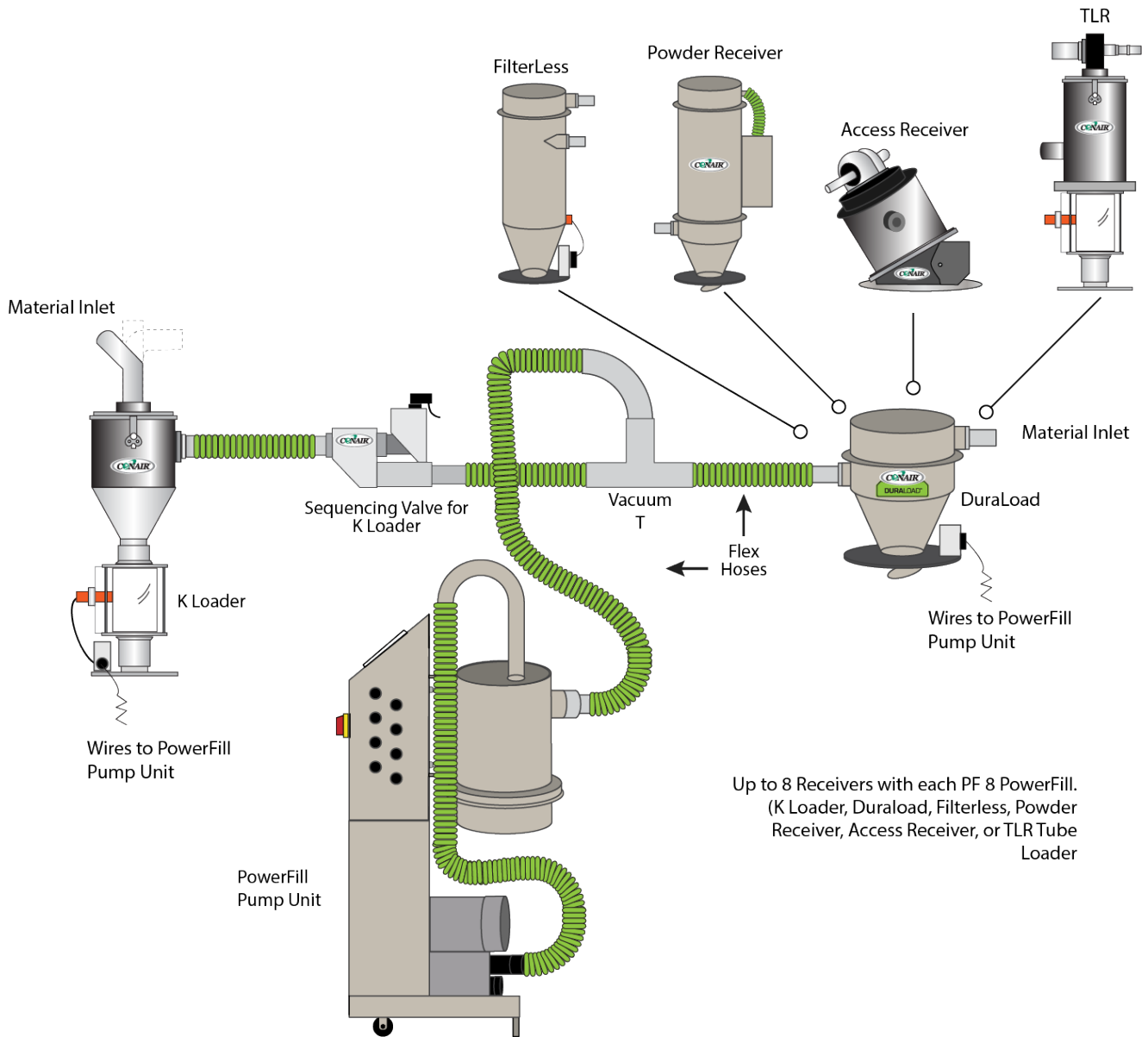

Figure 2  
PowerFill with Dual Loaders

PowerFill PF-8 can be connected to up to 8 receivers. Those receivers can be DuraLoad, Access Receivers (AR), Powder Receivers (PR), TC Loaders, or TLR Tube Loaders.

# Operation

---

Start-up .....	4-2
Single Loader Models .....	4-2
Ratio Models .....	4-3
Dual Loader Models .....	4-3
PowerFill A-B Control.....	4-4

## Start-Up

Before starting the pump, refer to the appropriate loader and control system instructions.

With the vacuum line temporarily disconnected from the pump, turn the main control switch on to check for proper motor rotation. Air should be drawing into the pump through the inlet adapter, and outward through the blower discharge. If the airflow is backwards, then the pump is running in reverse. With the disconnect switch in the OFF position, reverse the connections of two of the 3-phase leads. Once the direction of rotation is correct, reconnect the vacuum line to the pump inlet; the unit is ready to operate. For proper system orientation, refer to appropriate loader and control instructions. Do not exceed maximum pump vacuum rating.

## Single Loader Models

Single loader models of the PowerFill are equipped with a control that provides load time adjustment as well as unload time adjustment. Ratio loader models are equipped with a second setting to allow the percentage of regrind material desired to be set accordingly.

Load time should be set to allow the PowerFill pump to come on, load the vacuum loader's hopper with material, and then turn off, with enough Unload ( off) time to allow the loader to dump its load into the receiving vessel below it. Load times may be approximated based upon viewing the flow of material through the loader's flex hose. Too much time will tend to clog the loader's screen or the PowerFill's dust collector. Too little time may not allow a sufficient load of material to be drawn into the loader resulting in poor loading efficiency and difficulty of the loader dropping the minimal load into the receiving vessel below.

Unload time is normally set to a satisfactory level at the factory, but may be adjusted if necessary.

## Ratio Models

Ratio models must be adjusted to mix the proper amount of regrind to the virgin material with each load cycle. Load time will be adjusted in approximately the same way as described above. The load time will provide the total on time for the vacuum motor while the regrind percentage dial will split the load time signal into cycles made by the ratio mixing valve on the loader.

The number of virgin/regrind cycles that occur with each loading sequence is adjustable to allow for a prescribed amount of premixing of the materials as they enter the loader. This adjustment, like unload time, is pre-adjusted at the factory, but may be fine-tuned with a small slot headed screwdriver on the PC board within the control.

Keep in mind that the introduction of another material into the loader will normally decrease the filling efficiency of the loader's hopper and load time may need to be increased to allow for the additional conveying of the second material. Furthermore, the addition of more virgin/regrind cycles with each load will further decrease loading efficiency and require more load time. Trial and error adjustments are best suited to reach your specific desired loading parameters.

## Multiple Loaders

PowerFill PF-8 pumps are equipped to provide vacuum power and control for multiple loaders. The control is specifically programmed to provide a sequencing operation to allow the vacuum power to be directed to each loader, in sequence, based upon their individual demands. Interconnection of these controls is performed at the factory and load times may simply be set in the same manner as described above under "Single Loader Models".

 **NOTE:** If your specific PowerFill model contains two different loader formats; ie: One Single Tube and One Ratio Control, be sure to connect the proper interconnection cable to allow each loader to properly communicate with the appropriate control within the PowerFill. On multiple loader applications, the control may start the pump based upon the demand level signal being received from the loader. Once started, the PowerFill will direct vacuum to the loader by the opening of the vacuum sequencing valve accompanying that specific loader. At the end of the load time for that loader, the PowerFill's sequencing control will "scan" the demand level switch of the other loaders to see if they require material. If they do, the PowerFill pump will remain on, the sequencing valves will open/close accordingly and vacuum will be directed to the second loader, etc.

 **NOTE:** At no time should more than one loader attempt to fill at the same time. The connection of air to all loaders is very important in multiple loader systems, to assure that not only the specific loader in operation works, but also that the sequencing valve connected to the other loaders shut off correctly, to allow full conveying vacuum to be directed to the correct loader.

# PowerFill A-B Control

## Start-up

Initial setup of the system should occur during startup, but the system can be reconfigured and parameters can be changed at any time to compensate for changes of the system layout or material changes.

The Main or Home screen is shown below as a starting point.

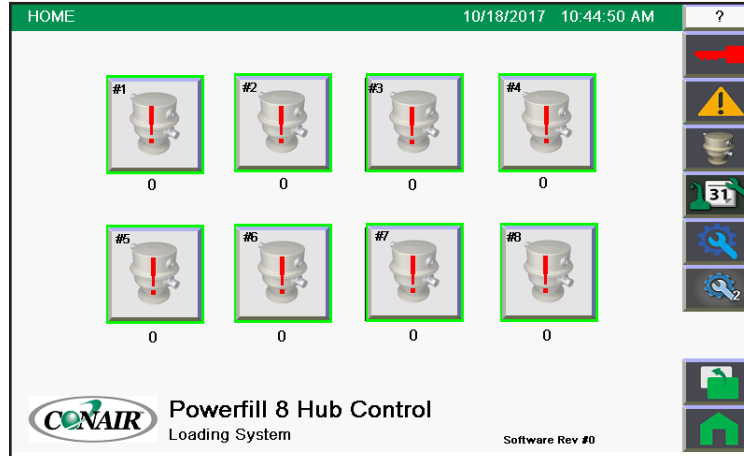

HMI Main or Home Screen

Depress the Loader icon to access the Loader Setup screens. Use the Next and Previous buttons to navigate through to all the loaders. On this system, there are a maximum of eight (8) loaders. Select the “Factory” button to access the factory set-up screen to assign the 8 devices to be loaders.

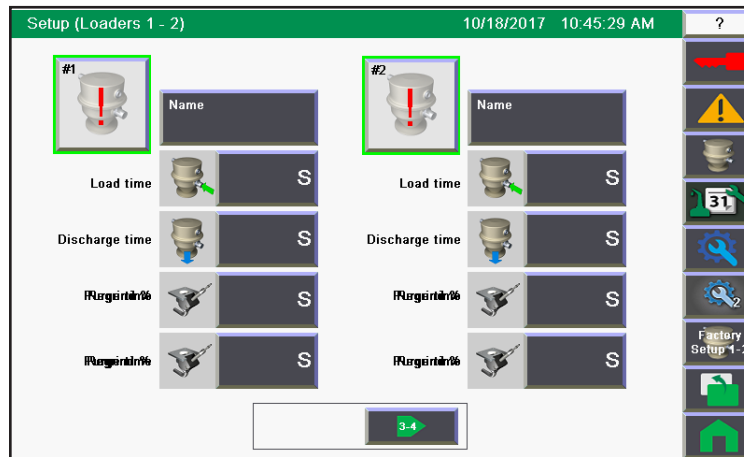

Loader Set-up Screen

# PowerFill A-B Control (Continued)

The Factory Set-up screen is seen below. Once the Loader Type is set to Standard, the next option pick box will appear and the optional Inputs and Outputs can be selected. NOTE: Input and Output (I/O) selection is based on the actual system that is available to you. Different systems and options may have the available input and output modules. If your system is a basic system, it will be limited to whatever I/O is present.

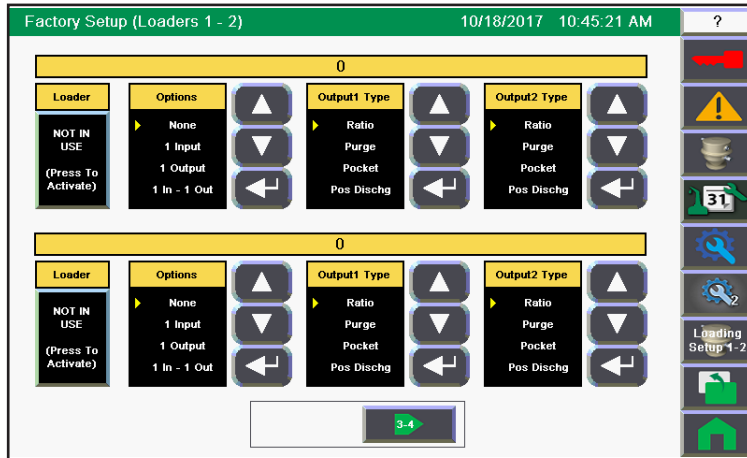

**Factory Set-up Screen** – Lets users change system to suit their needs

For a basic system, only a Standard loader with no options may be available. Once the loaders are selected, return to the “Home” screen to go to the next step. Select the Question Mark icon in the upper right corner of the screen. This will bring up the Help screen. Log in at a Maintenance level or higher (see User Levels on page ...) and select the Parameter Setup icon shown as a gear and wrench.

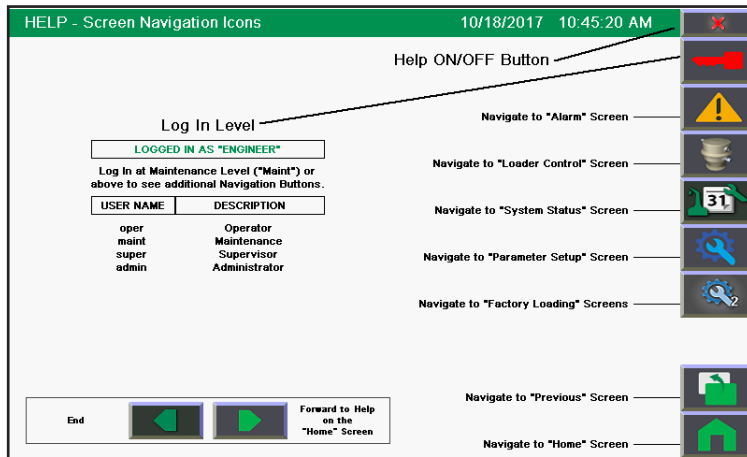

**Help Screen** – Log in to have access to some of the buttons

(Continued)

## PowerFill A-B Control (Continued)

On the Parameter screen, an Operator can set the amount of load attempts here. If the parameter for each loader is set for zero (0), no alarm is active. If it is set for one (1) or greater, an alarm will register if the demand signal doesn't go away after the entered value of load attempts.

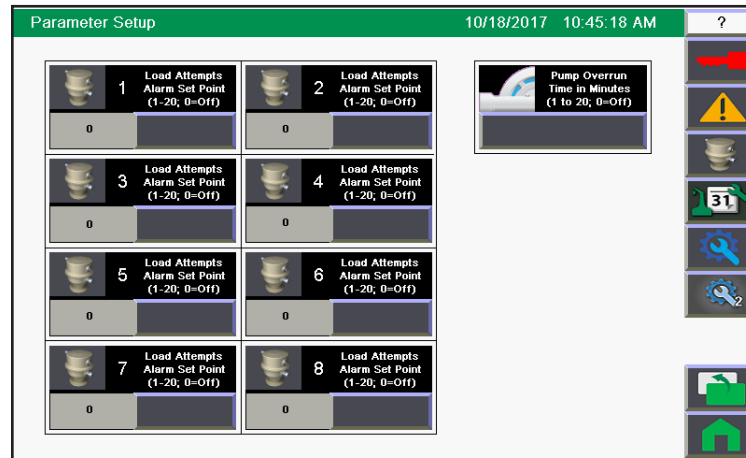

### Parameter Setup Screen

On the Parameter screen, an Operator can set the Pump Over Run time. Typical values are 2 to 5 minutes. Since the system is equipped with an Idle Mode valve, when a loader calls for service, the Idle Mode valve will switch from pulling ambient air to the vacuum line. When all loaders are satisfied, the Idle Mode valve will switch to pull ambient atmosphere air and the pump will stay running unloaded for the over run time.

An optional sequencing valve, or Idle Mode valve allows the pump to run between loading cycles, eliminating nuisance start and stop cycles that can reduce pump life.

To operate a loader or enable loader to start loading, start from the “MAIN” or “HOME” screen and select the Loader Icon by depressing it:



The box around the loader picture will be outlined in green when the loader is enabled. The red exclamation point will be visible when an alarm condition is present.

The loader icon will change through the different conditions of the loading cycle:

- Enabled
- In Demand
- Loading
- Unloading or Dump
- Alarm

# PowerFill A-B Control (Continued)

## User Level Listing

### HMI Log In for Screen Access

**User:**            **Password:**  
 oper                oper  
 maint               maint  
 super               super  
 admin               admin  
 service             for Conair use only

User Level	0	1	2	3	4	5
User name	N A	OPER	MAINT	SUPER	ADMIN	SERVICE
LOADER SETUP	NO	YES	YES	YES	YES	YES
FACTORY SETUP	NO	NO	YES	YES	YES	YES
IO TEST	NO	NO	YES	YES	YES	YES
SYSTEM STATUS	NO	NO	NO	NO	YES	YES
LOG OUT TO CONFIGURATION	NO	NO	NO	NO	NO	YES

### Operational Tips

- Load Time** – Enter a time that will represent the amount of material volume that will be needed by the process. Use real life data to determine the amount needed. The variables that affect this time is the distance the loader is away from the material source or hose length and how far away the pump is from the loader. Example: Put the load time at 30 seconds and measure the unloaded or dumped material that goes into a container. Adjust load time accordingly for more or less material.
- Discharge Time** – The amount of time it takes to unload or dump the loader’s contents fully. Allow for a complete dump of all material with the set time. Add a little more time as a safety factor. More time may be needed for different material sizing and shape. Large flakes can actually bridge and more time will be needed for complete expulsion.
- Load Attempts Alarm** – Also known in other control systems as Material Alarm or Alarm Check – If a Receiver or Vessel that is downstream of a loader is not filled by the loader within the number of tries set by the operator on the set point of the Load Attempts Alarm parameter, it trips this alarm. This function must be enabled by selecting a value greater than zero (0) and must include a sensor in the vessel below the loader. If demand signal hasn’t gone away after so many loads, this alarm is set. This lets the operator know something is wrong or load time is set too low. In this system, the “Demand Signal” has to go away (go false) to reset and clear alarm. Be aware that the alarm won’t be active until it sees the “Demand” signal go away once. The reason for this is that a vessel will start out to be empty and it may take several more loading cycles to bring it up to the Demand Sensor level – typically a Roto-Bin-Dicator. This is called no alarm on the “First Load”.

(Continued)

## PowerFill A-B Control (Continued)

- **Pump Over Run Time** – This system has a sequencing valve on the vacuum pump, or Idle Mode valve that allows the pump to run between loading cycles, eliminating nuisance start and stop cycles that can reduce pump life. When a loader calls for service, the Idle Mode valve will switch from pulling ambient air to the vacuum line. When all loaders are satisfied, the Idle Mode valve will switch to pull ambient atmosphere air and the pump will stay running unloaded for the over run time. This time can be set as a setpoint with a minimum time of one (1) minute to a maximum time of twenty (20) minutes.

# Maintenance

---

Preventative Maintenance Schedule ..... 5-2

Maintenance of the A-B Control ..... 5-3

# Preventative Maintenance Schedule

Routine maintenance will ensure optimum operation and performance of the PowerFill. We recommend the following maintenance schedule and tasks.

- **Weekly, or as needed.**

- Clean or replace the filter.**

You may need to clean filters more often than weekly. Frequency depends on how much material you process and how dusty or full of fines it is.

- Inspect hoses and hose connections.**

Check for damage, kinks, or loose hose clamps. Replace any hoses that show signs of damage or wear. Reposition and tighten loose hose clamps.

- **Monthly, or as needed.**

- Replace fuses in the A-B Control.**

The fuses may be replaced when necessary by qualified technicians and maintenance personnel. The controller should be powered down and placed in a safe condition before servicing.

- **Every six months**

- Check the vacuum relief valve for proper operation.**

The vacuum relief valve is designed to protect the pump from damage if the conveying line becomes clogged or obstructed or when idle mode is enabled.

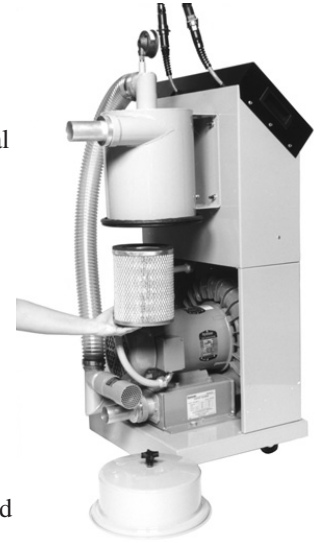

Rear View of PowerFill  
During Filter Change

# Maintenance of the A-B Control

The controller in this unit requires very little maintenance. Make sure the enclosure stays closed during normal operation to minimize ingress of dust and dirt. The fuses may be replaced when necessary by qualified technicians and maintenance personnel. The controller should be powered down and placed in a safe condition before servicing.

When cycling power or when unit is first turned on, the PLC does no active logic for approximately 1 minute, waiting for the HMI to power up and go through all its self-tests, then loading the application – which takes approximately 1 minute!

IP Address of HMI: 10.1.64.7

IP Address of PLC: 10.1.64.5

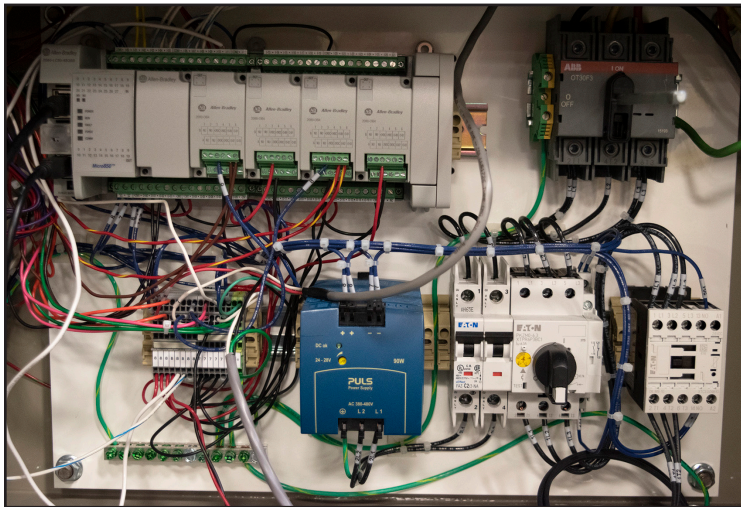

Inside View of PowerFill Control Panel



# Troubleshooting

---

Before Beginning .....	6-2
A Few Words of Caution.....	6-2
Identifying the Cause of a Problem .....	6-3
Troubleshooting the A-B Control .....	6-6

## Before Beginning

You can avoid most problems by following the recommended installation, operation and maintenance procedures outlined in this User Guide. If you have a problem, this section will help you determine the cause and tell you how to fix it.

Before you begin troubleshooting:

- Find any wiring, parts, and assembly diagrams that were shipped with your equipment.** These are the best reference for correcting a problem. The diagrams will note any custom features or options not covered in this User Guide.
- Verify that you have all instructional materials related to the PowerFill.** Additional details about troubleshooting and repairing specific components are found in these materials.
- Check that you have manual for other equipment connected in the system.** Troubleshooting may require investigating other equipment attached to, or connected with the control.

## A Few Words of Caution



**WARNING: Improper installation, operation or servicing may result in equipment damage or personal injury.**

This equipment should only be installed, adjusted, and serviced by qualified technical personnel who are familiar with the construction, operation, and potential hazards of this type of machine.

All wiring, disconnects, and fuses should be installed and adjusted by qualified electrical technicians in accordance with electrical codes in your region. Always maintain a safe ground. Do not operate the equipment at power levels other than what is specified on the machine serial tag and data plate.



**WARNING: Electrical hazard**



Before performing maintenance or repairs on this product, disconnect and lock out electrical power sources to prevent injury from unexpected energization or start-up. Always follow your company's internal lockout/tagout procedure for all maintenance and service.



**WARNING: Electrical hazard**

The PowerFill allows operators and maintenance personnel to disable and enable conveying system components. The unexpected energizing of these components could result in equipment damage or injury. Safe maintenance procedures should include:

- Disconnect any loader, pump or material valve from main power and/or compressed air sources before servicing.
- Ensure that all energy sources for the device are locked out and tagged.
- Before removing lockout devices and enabling system components, verify that all personnel and tools are clear of the machine.

# Identifying the Cause of a Problem

The Troubleshooting section covers problems directly related to the operation and maintenance of the PowerFill. This section does not provide solutions to problems that originate with other equipment. Additional troubleshooting help can be found in manuals supplied with the other equipment.

## Operation Problems

Problem	Possible Cause	Solution
<b>The vacuum pump does not reach the usual pressure.</b>	The vacuum line system is not leaktight.	Check hose and tubing connections throughout the system for leaks at couplers and stubs.
	Primary filter is partially clogged.	Perform routine filter cleaning, replacement or maintenance to clear the air path to the pump.
	Vacuum receiver valves are not closing properly, preventing other receivers from loading properly.	Systematically check each receiver that is connected to the pump and assure its vacuum valve closes firmly when it is not loading. No air should flow through the valve when it is closed. <i>Refer to the vacuum receiver instructions.</i>
	Shaft seal defective.	Repair the vacuum pump (Contact Conair Service).
	Idle mode valve is not receiving proper signal from <u>conveying system control</u> .	<u>Check conveying system control operation.</u> Refer to control instructions. Check wiring between control and pump.
	Idle mode valve is not closing fully. Malfunction of solenoid or internal plunger	Repair/replace idle mode valve solenoid. Repair/replace idle mode valve plunger
<b>The vacuum pump does not start.</b>	The pump starter is not supplied with the correct voltage or is overloaded.	Check nameplate and assure correct voltage is supplied. Reset overloads Check on/off switch, disconnect. Check control screen to make sure the receiver is getting a demand signal. Check gravity discharge valve or remote demand sensor for proper adjustment.
	The drive motor starter overload protection is set too low.	Compare the trip level of the drive motor starter overload protection with the amperage data on the nameplate, correct as necessary.

Contact Conair  
Customer Service  
1 800 458 1960.  
From outside of  
the United States,  
call: 814 437 6861

# Operation Problems

Problem	Possible Cause	Solution
<p><b>The vacuum pump starts, but labors or runs noisily or rattles; The drive motor draws too much current (compared to amperage readings at initial start-up).</b></p>	Impeller is jammed	Open vacuum pump cover and remove foreign body.
	Impeller is defective	Replace impeller.
	Roller bearing on drive motor side or vacuum pump side is defective.	Replace motor bearing or vacuum pump bearing.
	Loose connection(s) in the drive motor terminal box.	Tighten or rework loose connections.
	Not all legs of the 3-phase supply are properly connected. The drive motor is operating on only two phases.	Check the for proper connection of the wires in the starter box and in the fused disconnect switch (if supplied). Continue by checking supply voltage. Continue further by checking wiring at the motor itself.
<p><b>The pump operates, but generates a great deal of noise.</b></p>	Defective pump bearings.	Pump repair required. Contact Conair Service.
	Ball bearings lacking grease.	Regrease ball bearings.
<p><b>The pump operates, but very hot.</b></p>	Insufficient air ventilation, due to dust and dirt.	Clean the fan cowling, fan wheel ventilation grills and cooling fins.
	Insufficient air ventilation, due to proximity to walls or poor room ventilation.	<i>See “Operating Conditions-environment, 2 through 4” in the Installation Section of this User Guide.</i>
	Partial clogging of the dust collector, primary inlet filter or inlet filter screen.	Clean accordingly. Keep clean through periodic maintenance.
	Blockage of discharge line of pump	Remove blockage and/or allow pump to discharge air without restriction.
	Vacuum line too long or too small of a diameter	System design flaw. Contact Conair for re-engineering.

Contact Conair  
Customer Service  
1 800 458 1960.  
From outside of  
the United States,  
call: 814 437 6861

# Operation Problems

Problem	Possible Cause	Solution
The pump operates, but the loader is not receiving material.	Check receiver vacuum valve and discharge valve for leaks.	Check flex hoses and pipe for a tight “leak free” connection.
Pump operates, but material not moving.	Overfilling or feed tube uncovered	<p>Check the common line valves if used. Adjust receiver timing to avoid overfilling and backing material up into the common line valve.</p> <p>Make sure the vertical feed tube is covered up.</p>
Material going to the wrong loader.	Incorrect connections	<p>Check the receiver line connection is correct.</p> <p>Check the receiver naming and sequence number in the control matches the intended receiver.</p>

# Troubleshooting the A-B Control

Refer to Schematic and Layout Drawings for location and description of all components. Any service should be performed by a qualified technician.

Circuit Breaker	Fuse	Description:
SW1	Disconnect Switch	Control Power Switch - Supplies power to panel.
1CB	Circuit Breaker	Supplies and protects 460 VAC to Power Supply (24 VDC PS).

Ethernet Switch, HMI and PLC all get powered by 24 VDC (Wire No. 8, 7 is common).

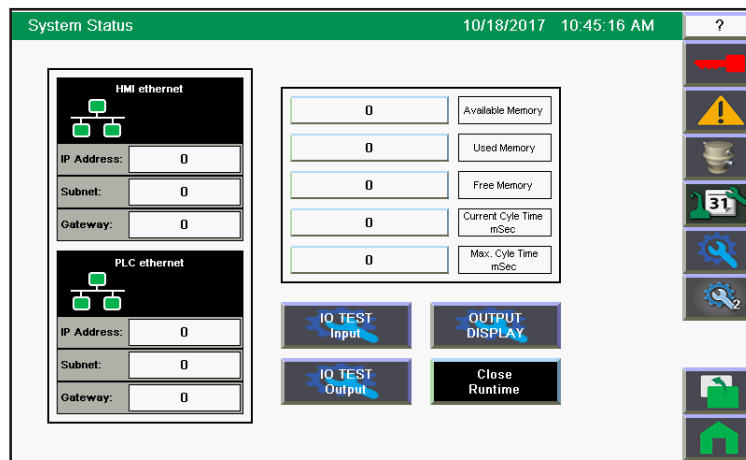

## System Status Screen

The System Status screen is accessed from the Main Help screen.

The system status screen shows the IP Address of the PLC and the HMI. Available, used and free memory are the current application in the HMI. The current cycle time is an active indication of the PLC. While the PLC is running, the number may change slightly as the PLC goes through different parts of the program.

## We're Here to Help

Conair has made the largest investment in customer support in the plastics industry. Our service experts are available to help with any problem you might have installing and operating your equipment. Your Conair sales representative also can help analyze the nature of your problem, assuring that it did not result from misapplication or improper use.

## How to Contact Customer Service

To contact Customer Service personnel, call:



 **NOTE:** Normal operating hours are 8:00 am - 5:00 pm EST. After hours emergency service is available at the same phone number.

**From outside the United States, call: 814-437-6861**

You can commission Conair service personnel to provide on-site service by contacting the Customer Service Department. Standard rates include an on-site hourly rate, with a one-day minimum plus expenses.

## Before You Call...

**If you do have a problem, please complete the following checklist before calling Conair:**

- Make sure you have all model, control type from the serial tag, and parts list numbers for your particular equipment. Service personnel will need this information to assist you.
- Make sure power is supplied to the equipment.
- Make sure that all connectors and wires within and between control systems and related components have been installed correctly.
- Check the troubleshooting guide of this manual for a solution.
- Thoroughly examine the instruction manual(s) for associated equipment, especially controls. Each manual may have its own troubleshooting guide to help you.

**Additional manuals and prints for your Conair equipment may be ordered through the Customer Service or Parts Department for a nominal fee.**

**Most manuals can be downloaded free of charge from the product section of the Conair website.**

**[www.conairgroup.com](http://www.conairgroup.com)**

## Equipment Guarantee

Conair guarantees the machinery and equipment on this order, for a period as defined in the quotation from date of shipment, against defects in material and workmanship under the normal use and service for which it was recommended (except for parts that are typically replaced after normal usage, such as filters, liner plates, etc.). Conair's guarantee is limited to replacing, at our option, the part or parts determined by us to be defective after examination. The customer assumes the cost of transportation of the part or parts to and from the factory.

## Performance Warranty

Conair warrants that this equipment will perform at or above the ratings stated in specific quotations covering the equipment or as detailed in engineering specifications, provided the equipment is applied, installed, operated, and maintained in the recommended manner as outlined in our quotation or specifications.

Should performance not meet warranted levels, Conair at its discretion will exercise one of the following options:

- Inspect the equipment and perform alterations or adjustments to satisfy performance claims. (Charges for such inspections and corrections will be waived unless failure to meet warranty is due to misapplication, improper installation, poor maintenance practices, or improper operation.)
- Replace the original equipment with other Conair equipment that will meet original performance claims at no extra cost to the customer.
- Refund the invoiced cost to the customer. Credit is subject to prior notice by the customer at which time a Return Goods Authorization Number (RGA) will be issued by Conair's Service Department. Returned equipment must be well crated and in proper operating condition, including all parts. Returns must be prepaid.

Purchaser must notify Conair in writing of any claim and provide a customer receipt and other evidence that a claim is being made.

## Warranty Limitations

**Except for the Equipment Guarantee and Performance Warranty stated above, Conair disclaims all other warranties with respect to the equipment, express or implied, arising by operation of law, course of dealing, usage of trade or otherwise, including but not limited to the implied warranties of merchantability and fitness for a particular purpose.**