



[www.conairgroup.com](http://www.conairgroup.com)

USER GUIDE

UGD030-0407

# Carousel Plus Dryer

W Series Models 15, 25, 50, 75 and 100 with DC-2 Controls



Please record your equipment's model and serial number(s) and the date you received it in the spaces provided.

It's a good idea to record the model and serial number(s) of your equipment and the date you received it in the User Guide. Our service department uses this information, along with the manual number, to provide help for the specific equipment you installed.

Please keep this User Guide and all manuals, engineering prints and parts lists together for documentation of your equipment.

Date: \_\_\_\_\_

Manual Number: UGD030-0407 \_\_\_\_\_

Serial Number(s): \_\_\_\_\_

Model Number(s): \_\_\_\_\_

See Screens 31 and 32 for Software Version

\*Display Firmware Version: \_\_\_\_\_

\*Display Menu Version: \_\_\_\_\_

\*Control Firmware Version: \_\_\_\_\_



**\* NOTE:** Displayed upon initialization, during power up, or on a data tag inside the door.

**DISCLAIMER:** Conair shall not be liable for errors contained in this User Guide or for incidental, consequential damages in connection with the furnishing, performance or use of this information. Conair makes no warranty of any kind with regard to this information, including, but not limited to the implied warranties of merchantability and fitness for a particular purpose.

# Table of Contents

## 1-1 Introduction

- Purpose of the user guide . . . . . 1-2
- How the guide is organized . . . . . 1-2
- Using the Carousel Plus W Series as a central dryer . . . . . 1-3
- Your responsibilities as a user . . . . . 1-3
- ATTENTION: Read this so no one gets hurt . . . . . 1-4
- How to use the lockout device . . . . . 1-6

## 2-1 Description

- What is the Carousel Plus W Series Dryer? . . . . . 2-2
- Typical applications . . . . . 2-2
- How it works . . . . . 2-4
- Specifications: Carousel Plus W Series Dehumidifying Dryer . . . . . 2-6
- Carousel Plus W Series Dehumidifying Dryer options . . . . . 2-7

## 3-1 Installation

- Unpacking the boxes . . . . . 3-2
- Preparing for installation . . . . . 3-4
- Positioning the dryer on the floor . . . . . 3-4
- Connecting the main power . . . . . 3-5
- Connecting the Process RTD probe . . . . . 3-6
- Connecting the setback RTD probe . . . . . 3-6
- Checking for proper air flow . . . . . 3-7
- Connecting the air hoses . . . . . 3-10
- Connecting the dryer to the hopper . . . . . 3-10

Connecting air hose adapters . . . . .	3-11
Connecting the aftercooler and optional precooler. . . . .	3-12
Mounting a loader on the hopper . . . . .	3-13
Testing the installation . . . . .	3-13
Using communications . . . . .	3-15

## 4-1 Operation

Carousel Plus W Series Dryer: control panel DC-2. . . . .	4-2
Carousel Plus W Series Dryer control functions . . . . .	4-3
Control function flow charts . . . . .	4-3
How to navigate the menu tree . . . . .	4-3
Control function descriptions . . . . .	4-11
To start drying . . . . .	4-35
To stop drying . . . . .	4-36
How to use the supervisor's password . . . . .	4-37
Using the auto start timer . . . . .	4-39
Setting the high setpoint limits . . . . .	4-40
Using the dewpoint monitor and dewpoint control. . . . .	4-41
Using the setback feature . . . . .	4-42
Setback feature guidelines . . . . .	4-43

## 5-1 Maintenance

Preventative maintenance checklist . . . . .	5-2
Checking the dewpoint . . . . .	5-3
Cleaning the hopper . . . . .	5-5
Cleaning the process filter. . . . .	5-6
Cleaning the regeneration filter. . . . .	5-7
Cleaning the aftercooler coils . . . . .	5-8
Cleaning the precooler coils . . . . .	5-9
Inspecting hoses and gaskets . . . . .	5-9

## 6-1 Troubleshooting

Before beginning . . . . .	6-2
A few words of caution . . . . .	6-3
<u>DIAGNOSTICS</u>	
How to identify the cause of a problem . . . . .	6-4
Shutdown alarms . . . . .	6-5
Passive alarms . . . . .	6-12
Dewpoint troubleshooting . . . . .	6-20
Poor material drying troubleshooting . . . . .	6-21
<u>REPAIR</u>	
Replacing fuses. . . . .	6-26
Checking heater solid state relays. . . . .	6-27
Checking or replacing temperature sensors . . . . .	6-28
Replacing the heaters	
Regeneration heater tube . . . . .	6-29
Process heater tube . . . . .	6-31
Replacing the desiccant wheel assembly . . . . .	6-33
Replacing the desiccant wheel motor . . . . .	6-34

## A Appendix

We're here to help . . . . .	A-1
How to contact customer service . . . . .	A-1
Before you call... . . . . .	A-1
Equipment guarantee . . . . .	A-2
Performance warranty . . . . .	A-2
Warranty limitations . . . . .	A-2

## B Appendix

Cleaning the precooler coils . . . . .	B-1
----------------------------------------	-----

# Addendum

Communication protocols for common controls - DC-2

# Introduction

---

Purpose of the user guide. . . . . 1-2

How the guide is organized. . . . . 1-2

Using the Carousel Plus W Series

    as a central dryer . . . . . 1-3

Your responsibilities as a user. . . . . 1-3

ATTENTION:

    Read this so no one gets hurt . . . . . 1-4

How to use the lockout device. . . . . 1-6

# Purpose of the User Guide

This User Guide describes the Conair Carousel Plus W Series Dryers and explains step-by-step how to install, operate, maintain, and repair this equipment.

Before installing this product, please take a few moments to read the User Guide and review the diagrams and safety information in the instruction packet. You also should review manuals covering associated equipment in your system. This review won't take long, and it could save you valuable installation and operating time later.

# How the Guide is Organized

Symbols have been used to help organize the User Guide and call your attention to important information regarding safe installation and operation.



Symbols within triangles warn of conditions that could be hazardous to users or could damage equipment. Read and take precautions before proceeding.



Numbers indicate tasks or steps to be performed by the user.



A diamond indicates the equipment's response to an action performed by the user.



An open box marks items in a checklist.



A circle marks items in a list.



Indicates a tip. A tip is used to provide you with a suggestion that will help you with the maintenance and the operation of this equipment.



Indicates a note. A note is used to provide additional information about the steps you are following throughout the manual.

# Using the Carousel Plus W Series as a Central Dryer

This manual incorporates the information necessary to use the Conair Carousel Plus W Series Dryer as a central dryer. Throughout this manual, information particular to central dryer application of the W Series Dryer is called out by the following treatment.



This box will contain information or highlight system differences particular to the application of the W Series dryer as a central dryer.

Central

## Your Responsibility as a User

You must be familiar with all safety procedures concerning installation, operation and maintenance of this equipment. Responsible safety procedures include:

- Thorough review of this User Guide, paying particular attention to hazard warnings, appendices and related diagrams.
- Thorough review of the equipment itself, with careful attention to voltage sources, intended use and warning labels.
- Thorough review of instruction manuals for associated equipment.
- Step-by-step adherence to instructions outlined in this User Guide.

## **ATTENTION:**

### **Read this so no one gets hurt**

We design equipment with the user's safety in mind. You can avoid the potential hazards identified on this machine by following the procedures outlined below and elsewhere in the User Guide.



**WARNING: Improper installation, operation, or servicing may result in equipment damage or personal injury.**

This equipment should be installed, adjusted, and serviced by qualified technical personnel who are familiar with the construction, operation, and potential hazards of this type of machine.

All wiring, disconnects, and fuses should be installed by qualified electrical technicians in accordance with electrical codes in your region. Always maintain a safe ground. Do not operate the equipment at power levels other than what is specified on the machine serial tag and data plate.



**WARNING: Voltage hazard**

This equipment is powered by three-phase alternating current, as specified on the machine serial tag and data plate.

A properly sized conductive ground wire from the incoming power supply must be connected to the chassis ground terminal inside the electrical enclosure. Improper grounding can result in severe personal injury and erratic machine operation.

Always disconnect and lock out the incoming main power source before opening the electrical enclosure or performing non-standard operating procedures, such as routine maintenance. Only qualified personnel should perform troubleshooting procedures that require access to the electrical enclosure while power is on.

## ATTENTION:

### Read this so no one gets hurt (continued)

We design equipment with the user's safety in mind. You can avoid the potential hazards identified on this machine by following the procedures outlined below and elsewhere in the User Guide.



#### **CAUTION: Hot Surfaces.**

Always protect yourself from hot surfaces inside the dryer and hopper. Also exercise caution around exterior surfaces that may become hot during use. These include the hopper door frame, the exterior of an uninsulated hopper, the return air hose and the dryer's process filter housing and moisture exhaust outlet.



#### **WARNING: Do not place aerosol, compressed gas or flammable materials on or near this equipment.**

The hot temperatures associated with the drying process may cause aerosols or other flammable materials placed on the dryer or hopper to explode.

## How to Use the Lockout Device

 **CAUTION:** Before performing maintenance or repairs on this product, you should disconnect and lockout electrical power sources to prevent injury from unexpected energization or start-up. A lockable device has been provided to isolate this product from potentially hazardous electricity.

Lockout is the preferred method of isolating machines or equipment from energy sources. Your Conair product is equipped with the lockout device pictured below. To use the lockout device:

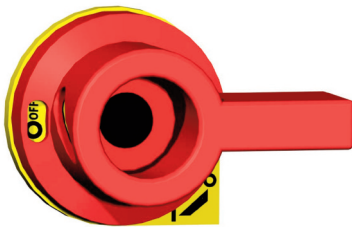

**1 Stop or turn off the equipment.**

**2 Isolate the equipment from the electric power.** Turn the rotary disconnect switch to the OFF, or “O” position.

**3 Secure the device with an assigned lock or tag.** Insert a lock or tag in the holes to prevent movement.

**4 The equipment is now locked out.**



 **WARNING:** Before removing lockout devices and returning switches to the ON position, make sure that all personnel are clear of the machine, tools have been removed, and all safety guards reinstalled.

To restore power to the dryer, turn the rotary disconnect back to the ON position:

**1 Remove the lock or tag.**

**2 Turn the rotary disconnect switch to the ON or “P” position.**



# Description

---

What is the Carousel Plus W Series Dryer? . . . 2-2

Typical applications . . . . . 2-2

How it works . . . . . 2-4

Specifications: Carousel Plus W Series

    Dehumidifying Dryer . . . . . 2-6

Carousel Plus W Series Dryer options . . . . . 2-7

# What is the Carousel Plus W Series Dryer?

The Carousel Plus W Series Dehumidifying Dryer produces hot, low-dewpoint air that removes moisture from hygroscopic plastics. The dryer pulls warm, moist air from a drying hopper and circulates it through a dehumidifying desiccant wheel. The dryer then heats the air to the drying temperature you selected and circulates it through the material in the hopper.

The dryer's closed-loop design ensures a continuous supply of hot, dehumidified air while preventing contamination from moisture in the plant.

## Typical Applications

- 1** Dryer on the floor; hopper on the throat (15 - 100).
- 2** Hopper on a floor stand; the dryer next to it.
- 3** Central dryer with ResinWorks.

The W Series Dryer can be used successfully in applications that require:

- A contamination-free drying environment.
- Drying temperatures within the ranges shown in the following table:

(continued)

## Typical Applications (continued)

Model	Drying Temperature Range
Low temperature (with precooler)*	100° - 150°F {38° - 66°C}
Standard	150° - 240°F {66° - 116°C}
High heat (with aftercooler)*	150° - 375°F {66° - 191°C}
Low-high (with aftercooler & precooler)*	100° - 375°F {38° - 191°C}

\* See page 3-12 and Appendix B.

- Throughput rates of 15 to 100 lbs {6.8 to 37.3} per hour (some materials can be ran at a higher rate).
- Dewpoints of -40°F {-40°C}.

### Use the aftercooler when:

- You are drying at temperatures over 240°F {116°C}.
- Throughput rates are less than 50% of the dryer's rated capacity.
- You are pre-drying material at temperatures over 150° F {66°C}.

### Dryer Standard Features:

- Audible and visual alarm
- Temperature setback
- Dewpoint monitor/dewpoint control
- DeviceNet communications (Alternate communications are available: Modbus, SPI and Ethernet)



Central

When supplied for central drying applications, the W Series Dryer is not equipped with a process heater. Therefore, as a central dryer, the W dryer will only supply dry air to the hoppers.

# How It Works

The Carousel Plus W Series Dryer achieves continuous, closed loop drying by passing air simultaneously through two heaters and a continuously rotating desiccant wheel.

## ■ THE PROCESS (DRYING) CYCLE

The process blower pulls moist air from the top of the drying hopper. The air passes through the process filter and aftercooler, then into the desiccant wheel, where moisture is removed. The now dry air moves through the optional precool (if installed) and process heater, where it is heated to the drying temperature selected by the operator. The hot, dry air is delivered to the hopper where a spreader cone evenly distributes the air through the material.



Central

### THE PROCESS (DRYING) CYCLE

The process blower pulls moist air from the top of the drying hopper. The air passes through the process filter and aftercooler, then into the desiccant wheel, where moisture is removed. The dry air is delivered to the hopper (after it passes through the optional precool, if installed) where a spreader cone evenly distributes the air through the material.

## ■ The Regeneration Cycle

The regeneration blower pulls air through the regeneration filter into the dryer's regeneration heater. The air is heated to 350° F {177° C} before it is pushed into the "wet" section of the wheel. The hot air purges moisture from the desiccant. The moist air is blown out the exhaust at the back of the dryer.

## □ The Cooling Cycle

Regenerated desiccant must be cooled before it rotates back into the process cycle. The process blower pushes a small amount of air through the cooling section of the desiccant wheel. The cooling air then passes through the aftercooler and repeats the circuit.

# How It Works (continued)

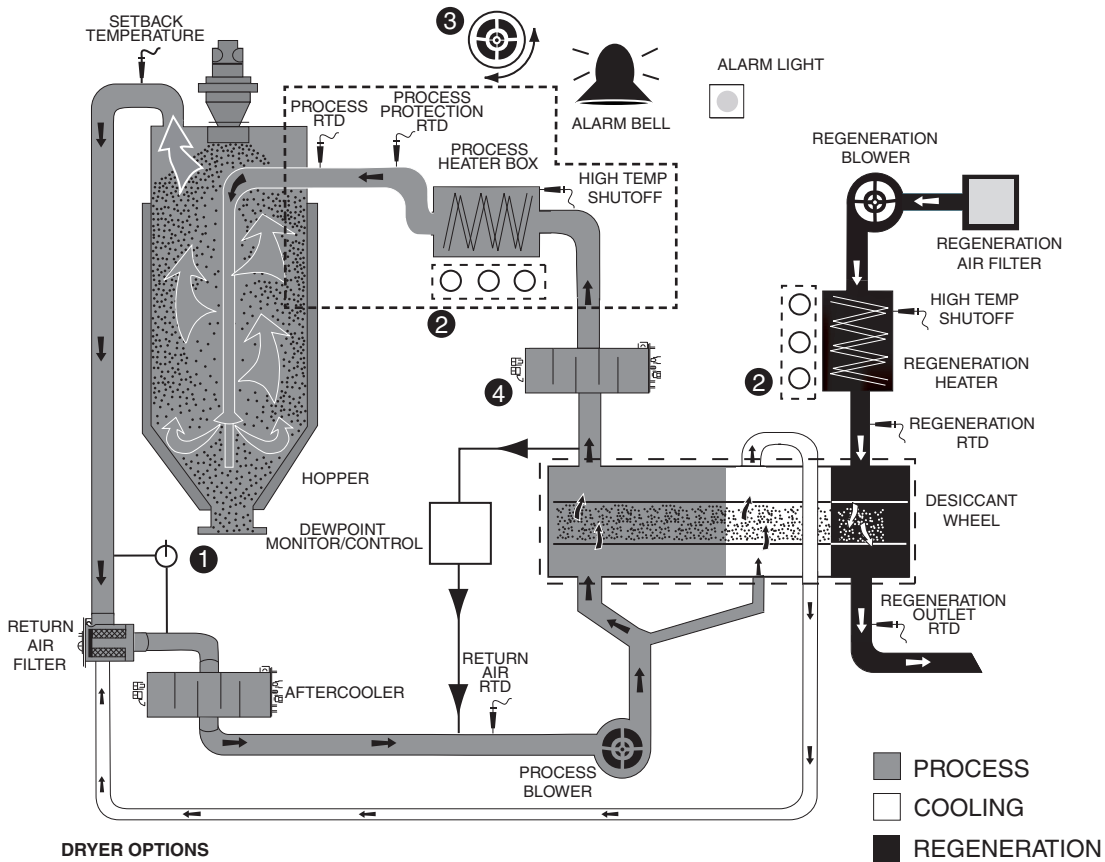

Description 2



Central

The components identified by this type of box in the drawing are not supplied with the W Series Dryer when it is configured as a central dryer.

# Specifications: Carousel Plus W Series Dehumidifying Dryer

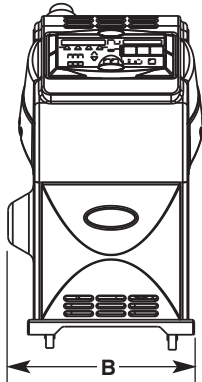
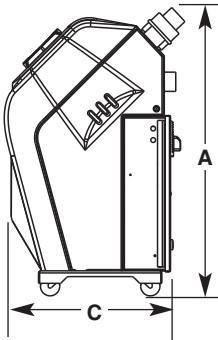

MODEL	W15	W25	W50	W75	W100
<b>Performance characteristics</b> (with full hopper)					
Drying temperature	All models 150 - 375°F {66 - 191°C} with options				
Dewpoint	All models -40°F {-40°C}				
<b>Dimensions</b> inches (cm)					
A - Height	36.0 {91.5}		43.5 {110.5}		
B - Overall width	18.0 {45.7}		29.0 {73.7}		
C - Depth	21.0 {53.3}		28.5 {72.4}		
Outlet/inlet tube size OD	2.5				
<b>Weight</b> lbs {kg}					
Standard Dryer Installed	180 {82}	180 {82}	220 {91}	220 {91}	220 {91}
<b>Voltage</b> - Total Amps					
208 V/3 phase/60 Hz	14.7	14.7	19.7	20.6	NA
230 V/3 phase/60 Hz	13.3	13.3	17.8	18.6	24.9
400 V/3 phase/50 Hz*	7.7	7.7	10.2	10.7	14.3
460 V/3 phase/60 Hz	6.7	6.7	8.9	9.3	12.4
575 V/3 phase/60 Hz	5.3	5.3	7.1	7.5	10.0
<b>Total kilowatts</b> † kw {BTU/min}	2.1 {120}	2.1 {120}	3.3 {188}	4.1 {233}	4.4 {250}
<b>Water requirements</b> {for optional aftercooler or precooler}‡					
Recommended temperature§	45° - 85°F (7.2 - 29.4°C)				
Water flow gal./min. {liters/min.}	1 {4.6}		2 {7.6}		
Water connections NPT	3/8 in. NPT				

## SPECIFICATION NOTES:

\* Dryers running at 50 Hz will have 17% less airflow, and a 17% reduction in material throughput.

† Total kW listed at a process setpoint of 250°F {121°C} and a regeneration temperature of 350°F {177°C}.

‡ When drying below 150°F {66°C} a precooler is required.

§ Temperatures above or below the recommended levels may affect dryer performance. Tower, chiller or municipal water sources can be used.

Specifications may change without notice. Consult a Conair representative for the most current information.

TPDS017-0305-REV

# Carousel Plus W Series Dehumidifying Dryer Options

- **Volatile trap** - The volatile trap is recommended if drying materials that produce volatiles that condense into a waxy or oily residue and/or if the material contains excessive fines. (Used only in conjunction with the standard aftercooler.)
- **Precooler** - The precooler reduces the temperature of air flow after the desiccant wheel and before the process heater, enables the dryer to control temperatures at low setpoints (100° - 150°F {38° - 66°C}).
- **Filter check** - The filter check sensor will activate a passive alarm when the process filter is clogged or needs to be replaced.
- **Heater current monitor** - The heater current monitor measures the total amperage across both the process and regeneration heaters and the pre-determined power consumption values for the blowers and the control.
- **CFM monitor** - The CFM monitor measures the cubic feet per minute of air flow across the inlet/outlet of the process blower.
- **Communications** - Allows the dryer to be networked to industrial control systems. DeviceNet is standard. Modbus, SPI and Ethernet are available.



# Installation

---

Unpacking the boxes . . . . .	3-2
Preparing for installation . . . . .	3-4
Positioning the dryer on the floor. . . . .	3-4
Connecting the main power. . . . .	3-5
Connecting the process RTD probe . . . . .	3-6
Connecting the setback RTD probe . . . . .	3-6
Checking for proper air flow . . . . .	3-7
Connecting the air hoses . . . . .	3-10
Connecting the dryer to the hopper . . . . .	3-10
Connecting air hose adapters . . . . .	3-11
Connecting the aftercooler and optional precooler . . . . .	3-12
Mounting a loader on the hopper . . . . .	3-13
Testing the installation. . . . .	3-13
Using communications . . . . .	3-15

# Unpacking the Boxes

The Carousel Plus W Series Dryer comes in one to four boxes, depending on the model and options ordered. The boxes could include (depending on the options selected):

- Carousel Plus W Series Dryer
- Delivery air hose - 10 ft {3.05 m} - Insulated with High Heat option.
- Return air hose - 10 ft {3.05 m}
- Process RTD
- Setback RTD
- User manual

**1 Carefully remove the dryer and components** from their shipping containers. Note that the dryer is secured to its shipping container with two bands and blocking.

**2 Remove all packing material,** protective paper, tape, and plastic.

**3 Carefully inspect all components** to make sure no damage occurred during shipping, and that you have all the necessary hardware.

(continued)

## Unpacking the Boxes (continued)

**4 Take a moment to record serial numbers** and electrical power specifications in the blanks provided on the back of the User Guide's title page. The information will be helpful if you ever need service or parts.

**5 You are now ready to begin installation.**

Follow the preparation steps on the next page, then choose one of the three mounting options:

- Dryer on the floor; hopper on a floor stand (see page 3-4).
- Dryer on the floor; hopper machine mounted.
- Central dryer with ResinWorks system.

# Preparing for Installation

The Carousel Plus W Series Dryer is easy to install if you plan the location and prepare the mounting area properly.

## 1 Make sure the mounting area provides:

**A grounded power source supplying the voltage and correct current** for your dryer model. Check the dryer's serial tag (on the side of your control box) for the correct amps, voltage, phase, and cycles. Field wiring should be completed by a qualified personnel to the planned location for the dryer. All electrical wiring should comply with your region's electrical codes.

**A source of water, for the aftercooler and/or the optional precooler.** The Carousel Plus W Series dryer's aftercooler and optional precooler can use 2 gals./min. {7.6 liters/min.} tower, city, or chiller water at temperatures of 45° to 85°F {7° to 29°C}. Pipe should be ran to the planned dryer location. Use flexible hose to connect the water pipes to the aftercooler and/or precooler.

**Minimum clearance for safe operation and maintenance.** You should maintain 24 in. {61 cm} clearance on all sides of the dryer.

•❖ If you plan to use vacuum or compressed air loaders to fill the hopper, install conveying lines to the drying hopper location.

# Positioning the Dryer on the Floor

**1 Lift the dryer from the shipping container** using a fork truck.

**2 Position the dryer on the floor** near the processing machine. Make sure the location allows for the connection of all hoses.

# Connecting the Main Power



**CAUTION:** Always disconnect and lock out the main power sources before making electrical connections. Electrical connections should be made only by qualified personnel.

**1 Open the dryer's electrical enclosure.** Turn the disconnect dial on the dryer door to the Off or "O" position. Lock out the main power (see Page 1-6 for complete lock out information). Turn the captive screw, and swing the door open.

**2 Insert the main power wire** through the knockout in the side of the enclosure. Secure the wire with an appropriate strain relief.

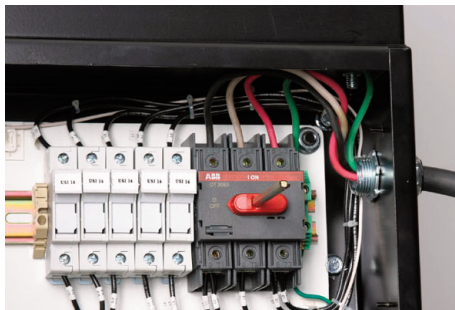
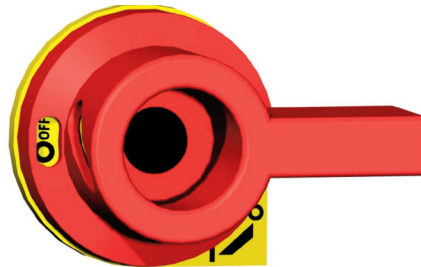

**IMPORTANT:** Always refer to the wiring diagrams that came with your dryer before making electrical connections.

**3 Connect the power wires** to the three terminals at the top of the power disconnect.

**4 Connect the ground wire** to the ground lug.

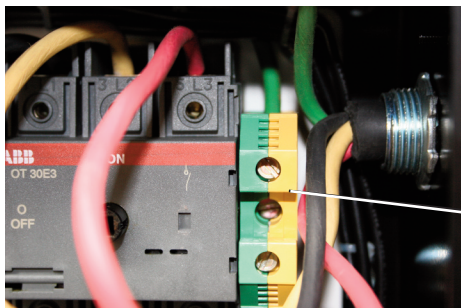

Ground Lug

## Connecting the Process RTD Probe



Central

When configured as a central dryer, there is no process heater or process RTD in the system. Therefore, installation and connection of the RTD probe and/or setback probe is not applicable.

The process RTD probe monitors the temperature of the drying air as it enters the hopper. If the probe is not installed correctly, temperature readings will be inaccurate.

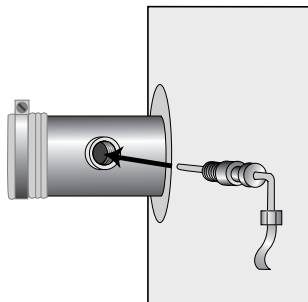

- 1 Insert the probe at the inlet to the hopper.** The end of the probe must not touch the walls of the tube. The tip of the probe should be approximately in the center of the tube. Tighten the compression fitting to lock the probe in place.



- 2 Plug the probe's cable into the receptacle labeled process on the left side of the electrical enclosure.** Hand tighten the connector. Coil any excess cable and secure it with a wire tie.

## Connecting the Setback RTD Probe

- 1 Insert the probe in the hopper outlet** at the top of the hopper. The end of the probe must not touch the walls of the tube. The tip of the probe should be approximately in the center of the tube. Tighten the compression fitting to lock the probe in place.
- 2 Plug the probe's cable into the receptacle labeled setback on the left side of the electrical enclosure.** Hand tighten the connector. Coil any excess cable and secure it with a wire tie.

# Checking for Proper Air Flow

This procedure is required on W 50 - 100 models if the phase detection option was not ordered with the dryer.

**IMPORTANT:** This procedure must be performed before the dryer's air hoses are connected to the hopper or before loading material into the hopper.

**CAUTION:** If the air flow direction is incorrect due to improper phase connection, material from the hopper can be pulled into the process heater, causing permanent damage to this equipment.

- 1 Turn on the main power to the dryer.** Make sure the dryer's disconnect dial is in the "ON" position. This powers up the control and the display lights will illuminate.
- 2 Select the setpoint temperature by pressing the select category button under the setpoint temperature display.** Once selected, the number will flash.
- 3 Set the drying temperature.** Press the select category button under the setpoint value until it blinks then use the setpoint adjustment (+) or (-) buttons or enter a low setpoint temperature (150°F {66°C}) on the numeric keypad and then press enter.



Central

When configured as a central dryer, the drying temperature can not be set since there is no process heater in the system.

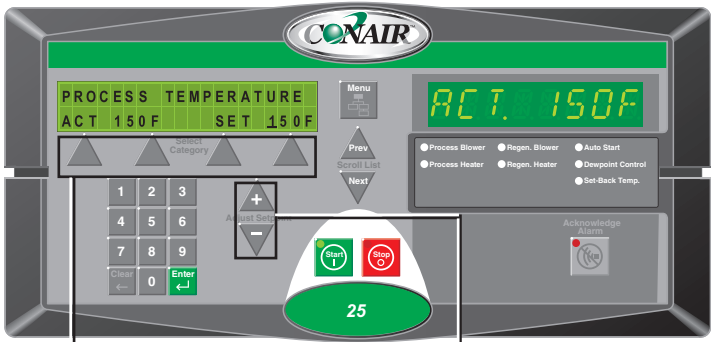

Select Category Buttons

Setpoint Adjustment Buttons

## Checking for Proper Air Flow (continued)

- 3 Press the START button.** Hold your hand near the delivery air outlet. You should feel air blowing out of the outlet.



**CAUTION: Hot surface** Do not place your hand directly on the delivery air outlet. The outlet and the air can get hot enough to burn your hand.

- 4 Press the STOP button.**



 **NOTE:** If the dryer is running for more than 20 to 30 seconds, the Process Loop Break alarm may occur because the Process RTD is not seeing the expected temperature rise.



Return  
Air Inlet

Dry Delivery  
Air

Moisture  
Exhaust

- 5 If air flow is incorrect disconnect power,** follow proper lockout procedures and swap any 2 of the 3 main power wires. *(see photo, page 3-9)*



**WARNING:** All wiring, disconnects, and fuses should be installed by qualified electrical technicians in accordance with electrical codes in your region. Always maintain a safe ground. Do not operate the equipment at power levels other than what is specified on the the machine serial tag and data plate.

## Checking for Proper Air Flow (continued)

 **INSTALLATION NOTE: Models 50, 75 and 100**

These models use a three-phase process blower. If the dryer shuts down and a Process Loop Break shutdown alarm is indicated within the first few minutes of operation, check for proper air flow.



If the air flow is reversed, the process blower is turning in the wrong direction. Turn off and lock out the main power source. Open the electrical enclosure and reverse any two leads connecting the main power supply to the dryer.

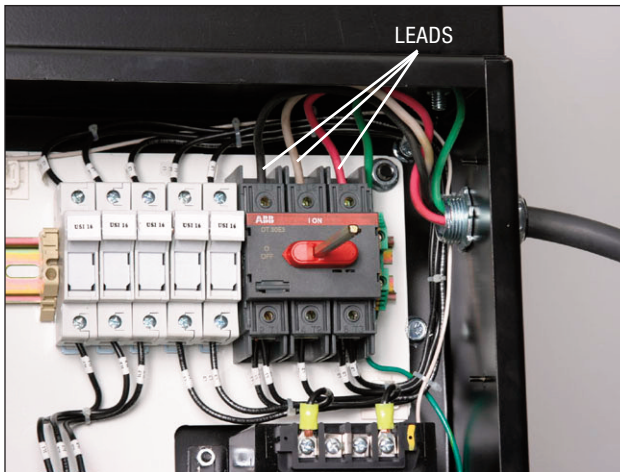

 **NOTE:** If the dryer is running for more than 20 to 30 seconds, the Process Loop Break alarm may occur because the Process RTD is not seeing the expected temperature rise.



**WARNING:** All wiring, disconnects, and fuses should be installed by qualified electrical technicians in accordance with electrical codes in your region. Always maintain a safe ground. Do not operate the equipment at power levels other than what is specified on the the machine serial tag and data plate.

## Connecting the Air Hoses

Using the two flexible hoses provided, connect the inlets and outlets of the drying hopper to the dryer. Check to make sure the dryer is located as close as possible to the hopper to reduce heat loss. (10 ft {3.05 m} of hose supplied)

If you have ordered an insulated hose, it should be installed between the dryer outlet and the hopper inlet.

**1 Attach one hose** from the return air inlet of the dryer to the return air outlet from the top of the hopper.

**2 Attach one hose** from the delivery air outlet of the dryer to the delivery air inlet of the hopper.

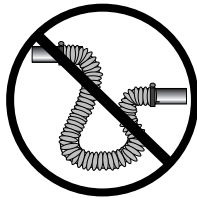

 **NOTE:** Do not allow the flexible hoses to kink or crimp.

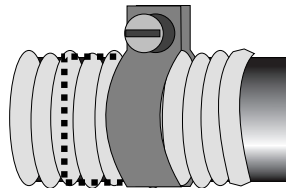

**3 Secure hoses with clamps.**

The hose clamp should be secured at least 1/4 inch {6.4 mm} from the end of the inlet or outlet tube.

**Hose adapters are available from Conair.**

Contact Conair Parts  
(800) 458 1960  
From outside of the  
United States, call:  
(814) 437 6861

## Connecting the Dryer to the Hopper

The W 15 - 100 dryers have 2 1/2 inch inlet and outlet hose connections.

 **NOTE:** If your dryer hose connection and your hopper hose connection are not the same size, you will need a hose adapter. Contact Conair Parts 1 800-458-1960.

# Connecting Air Hose Adapters

Depending on the hopper you purchased you may need to install an air hose adapter to connect the hopper to your dryer.

To connect the air hose adapter:

- 1** Place a high temperature gasket approximately half way down from the end of the dry air delivery outlet.

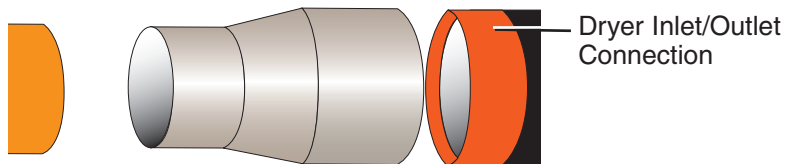

- 2** Place hose adapter inside high temperature gasket flush to the dryer outlet, secure with pressure clamp.

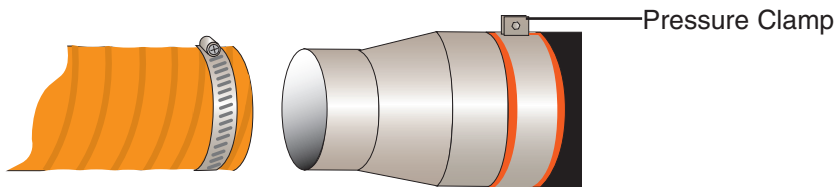

- 3** Attach the hopper inlet hose over the adapter, secure with clamp.

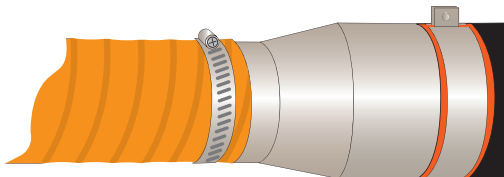

# Connecting the Aftercooler and Optional Precooler (Optional)

**IMPORTANT:** Do not move the Carousel Plus W series 15 -100 dryer with the aftercooler and/or optional precooler water hoses attached. You must detach the water inlet/outlet hoses and move the dryer to its new location and then reattach the water inlet/outlet hoses. Failure to do so will harm your equipment.

**IMPORTANT:** When a precooler is purchased instead of an aftercooler, the precooler will be mounted in the aftercooler's location.

• **TIP:** Make the water supply and discharge / return connections with flexible hoses at least 24 in. {61 cm} long. This allows you to easily remove the aftercooler or optional precooler assembly for cleaning.

• **TIP:** If an optional flow control is also being installed with the aftercooler or optional precooler, the manual shut off valve should be installed on the inlet line for the flow control.

The aftercooler and optional precooler require 2 gals./min. {7.6 liters/min.} tower, city or chiller water and a discharge or return line.

- 1 Remove the two (2) screws that secure the dryer's plastic cover, then remove cover.**

 **NOTE:** 50-100 models have four (4) screws that secure the plastic cover to the dryer.

- 2 Connect water fittings to the 90 degree tubing bend of the aftercooler or optional precooler. Seal the threads with silicon tape.**

- 3 Connect water supply inlet. Secure with hose clamp.**

- 4 Connect water supply outlet. Secure with hose clamp.**

- 5 Replace plastic cover, resecure screws.**



**IMPORTANT:** Turn the water off when the dryer is not in use to prevent condensation.

# Mounting a Loader on the Hopper

If you have a Conair loader or vacuum receiver, you can use the flange and mounting clips provided on the top of the hopper. Refer to the manuals that came with your receiver or loader for detailed installation instructions.

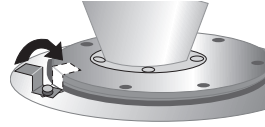

# Testing the Installation

You have completed the installation. Now it's time to make sure everything works.

- 1 Make sure there is no material in the hopper.** If you have mounted a loader or vacuum receiver on the hopper, disconnect the material inlet hose at the source or turn the loader off.
- 2 Turn on the main power to the dryer.** Make sure the dryer's disconnect dial is in the ON position. This powers up the control and the display lights will illuminate.
- 3 Set the drying temperatures.** Press temperature select with the select category button, and then press the Setpoint Adjust (+) or (-) buttons or enter a low setpoint temperature (150°F {66°C}) on the numeric keypad and then press enter.



Central

When configured as a central dryer, the drying temperature can not be set since there is no process heater in the system.

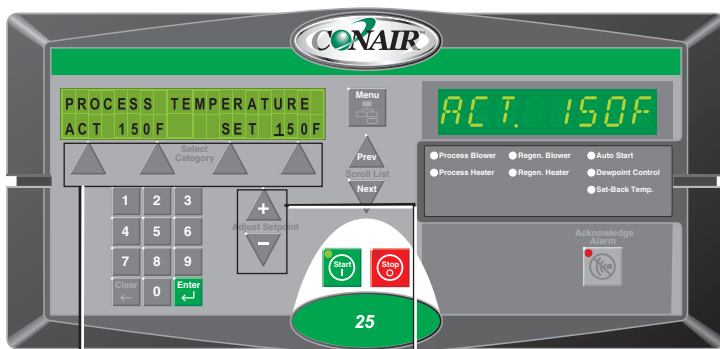

Select Category Buttons

Setpoint Adjustment Buttons

(continued)

## Testing the Installation (continued)

 **NOTE:** If the dryer is running for more than 20 to 30 seconds, the Process Loop Break alarm may occur because the Process RTD is not seeing the expected temperature rise.

### 4 Press the START button.



If everything is installed correctly:

- The green light on the start button will illuminate.
- The process and regeneration blowers turn on and the display LEDs will illuminate.
- The process and regeneration heaters turn on and the display LEDs will illuminate.
- The desiccant wheel starts turning.



Central

- The green light on the start button will illuminate.
- The process and regeneration blowers turn on and the display LEDs will illuminate.
- The regeneration heater turns on and the display LED will illuminate.
- The desiccant wheel starts turning.

### 5 Press the STOP button.



If everything is installed correctly:

- The blowers will continue running as needed to cool the heaters (until both heaters are less than 150°F {66°C}) or ten minutes, whichever is shorter.

**6 The test is over.** If the dryer performed the normal operating sequences as outlined, you can load the hopper and begin operation. If it did not, refer to the *Troubleshooting section* of the User Guide.

# Using Communications

The DeviceNet cable feature is a standard feature on W 15 - 100 dryers with DC-2 controls. It allows the dryer to be connected your communications network.

If the communications feature will NOT be used for your application, simply coil the cable to keep it out of the way. If the communications feature IS to be used for your application, please refer to the documentation supplied in the Communication Addendum of this manual.

To use the optional SPI, Modbus, Ethernet or standard DeviceNet communications, see the Addendum for hardware installation and configuration.



SPI Connection



DeviceNet Connection



Ethernet Connection





# Operation

---

Carousel Plus W Series Dryer:	
control panel DC-2 . . . . .	4-2
Carousel Plus W Series Dryer	
control functions . . . . .	4-3
Control function flow charts . . . . .	4-3
How to navigate the menu tree . . . . .	4-3
Control function descriptions . . . . .	4-11
To start drying . . . . .	4-35
To stop drying . . . . .	4-36
How to use the supervisor's password . . . . .	3-37
Using the auto start timer . . . . .	4-39
Setting the high setpoint limits . . . . .	4-40
Using the dewpoint monitor and	
dewpoint control . . . . .	4-41
Using the setback feature . . . . .	4-42
Setback feature guidelines . . . . .	4-43

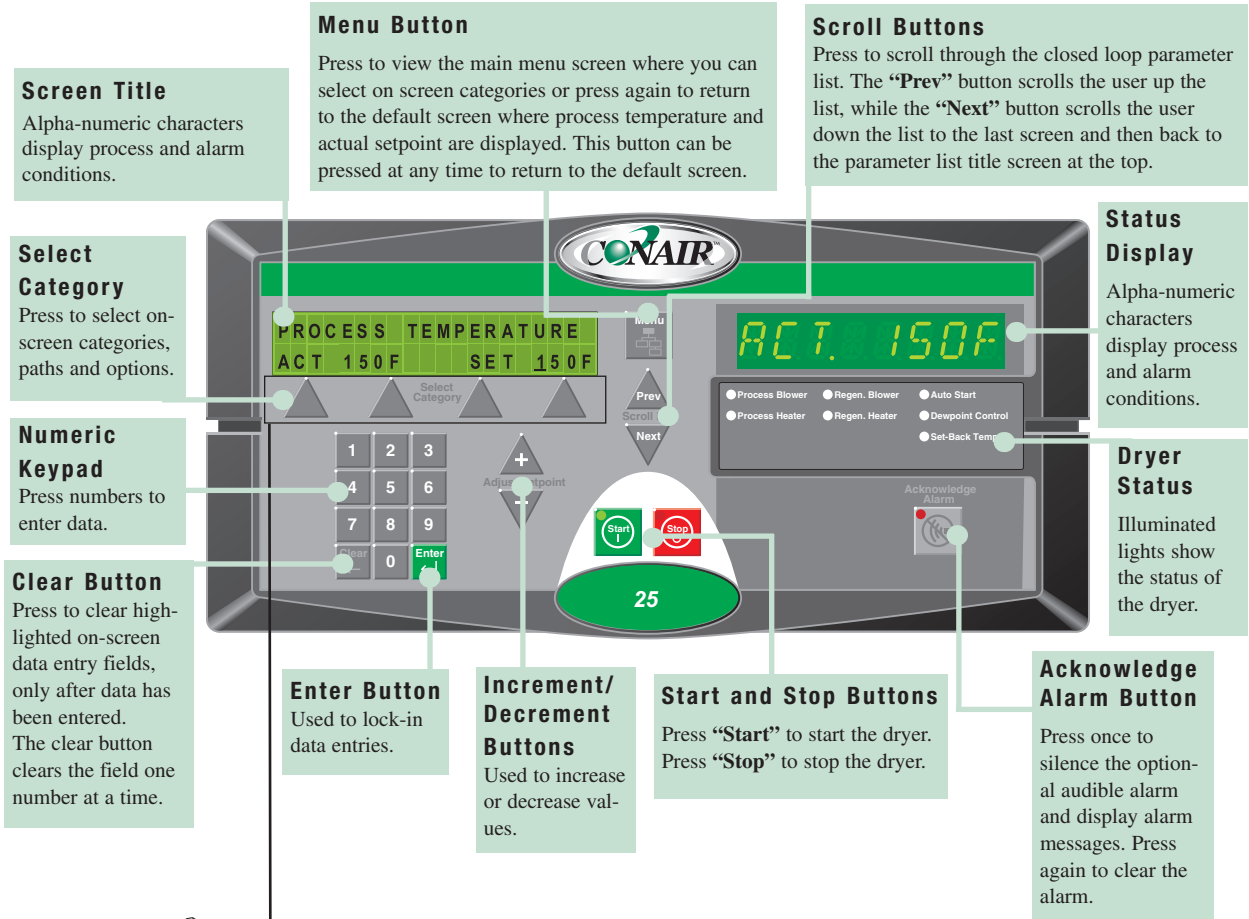
# Carousel Plus W Series Dryer: Control Panel DC-2



 **NOTE:** When changing a setpoint use the Select Category Key directly below the value to be changed. Once pressed the value will blink, then use the keypads or (+) (-) adjustment setpoints to enter the new value. Then press enter for the new value to be recognized.

# Carousel Plus W Series Dryer Control Functions

Dryer functions are values that you can set or monitor in the Screen Title and Status Display windows. Press the Menu button then the Scroll List “Next” or “Prev” buttons until the function you want to set or monitor appears in the Screen Title window.

## Control Function Flow Charts

The charts beginning on page 4-4 provide a quick summary of the control functions. For an explanation of each control function, see Control Function Descriptions (page 4-11). The screen numbers correspond with the numbers beside each block in the flow chart.

 **Note:** In the flow charts of the display screens that follow this page, the grey shaded screens denote optional functions. If the options were not purchased with the dryer, those screens will not appear. Most options can be purchased and installed in the field.

## How to Navigate the Menu Tree

To scroll through main menu, use scroll buttons (“Next”, “Previous”). Push “Menu” to access Dryer Main Menu. To access the Status, Setup, Diagnostic and Password screens, use the select category buttons under the digital read-out and then the scroll buttons (“Next”, “Previous”) to scroll through the parameter lists.

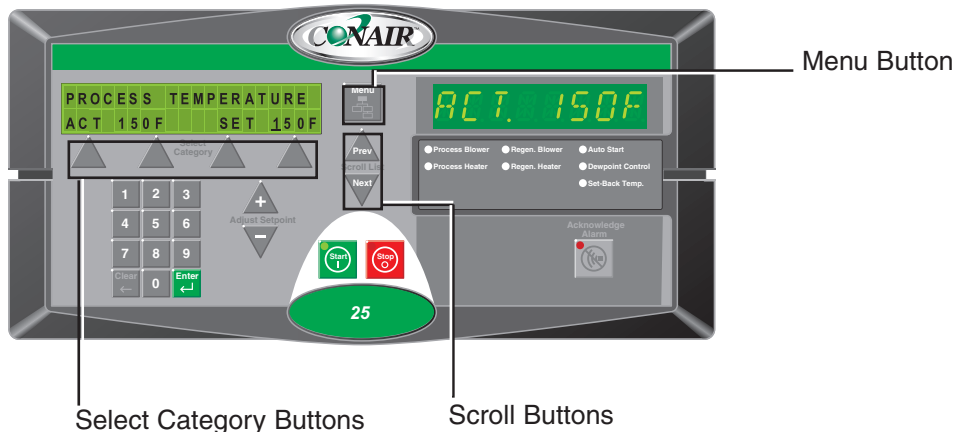

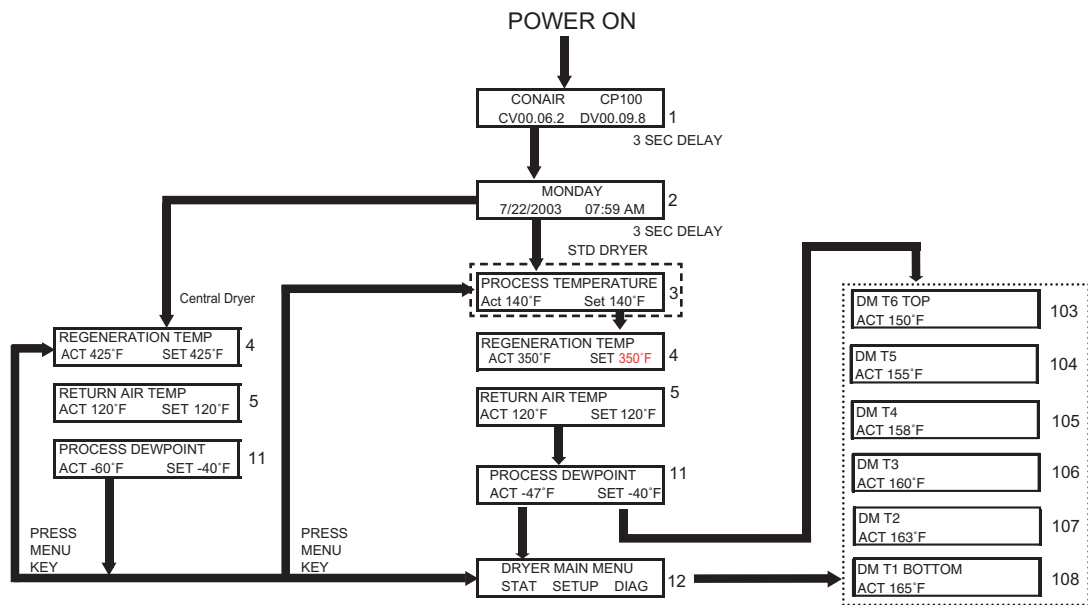

When configured as a central dryer, there is no process heater in the system. Therefore, any function associated with the process heater is not available for central dryer configurations.

**NOTE:** If you have purchased the DM-II (drying monitor) option, see the DM-II Appendix for information pertaining to its operation.

When the DM-II monitor option is purchased these screens will be displayed.

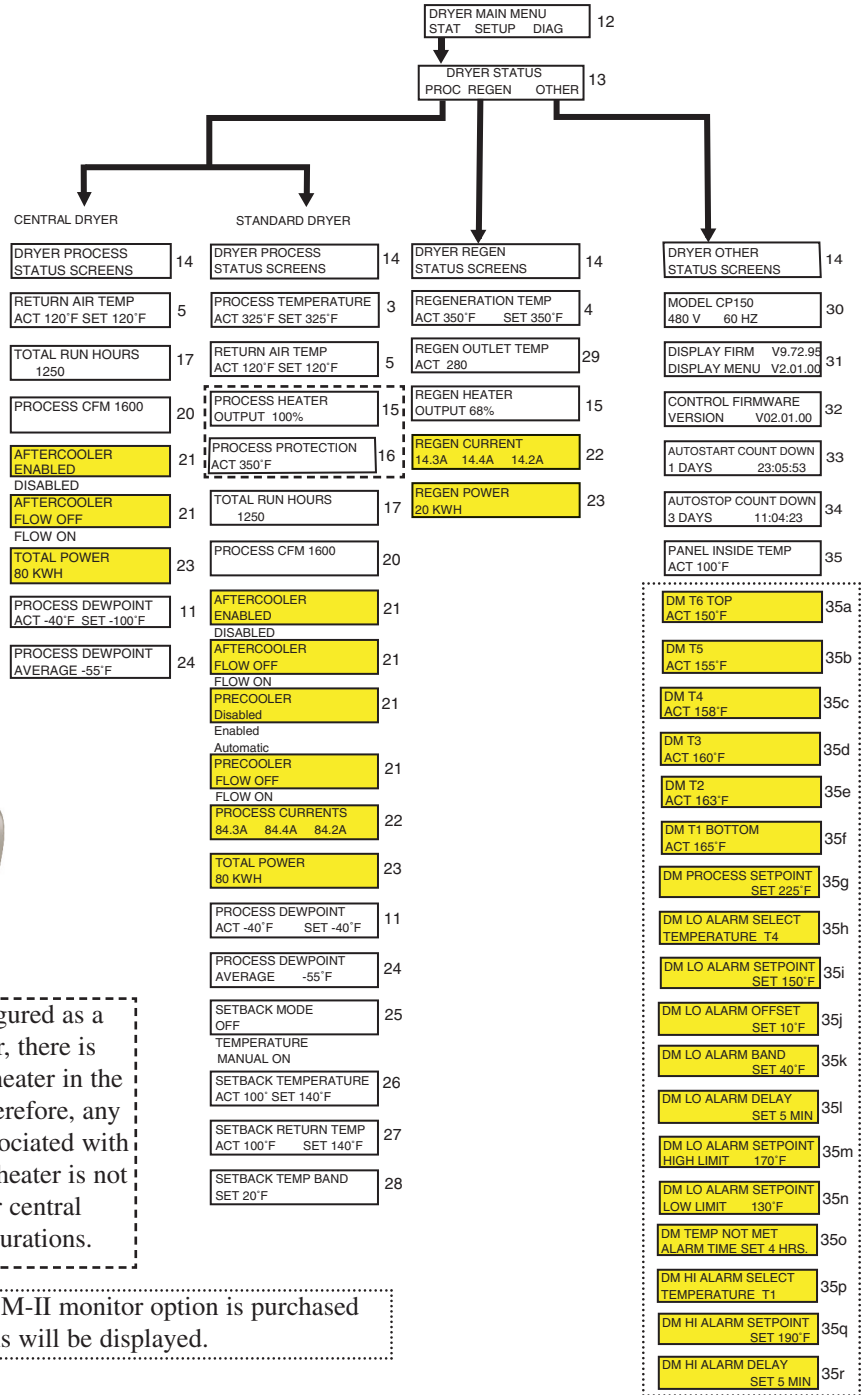

Central

When configured as a central dryer, there is no process heater in the system. Therefore, any function associated with the process heater is not available for central dryer configurations.

When the DM-II monitor option is purchased these screens will be displayed.

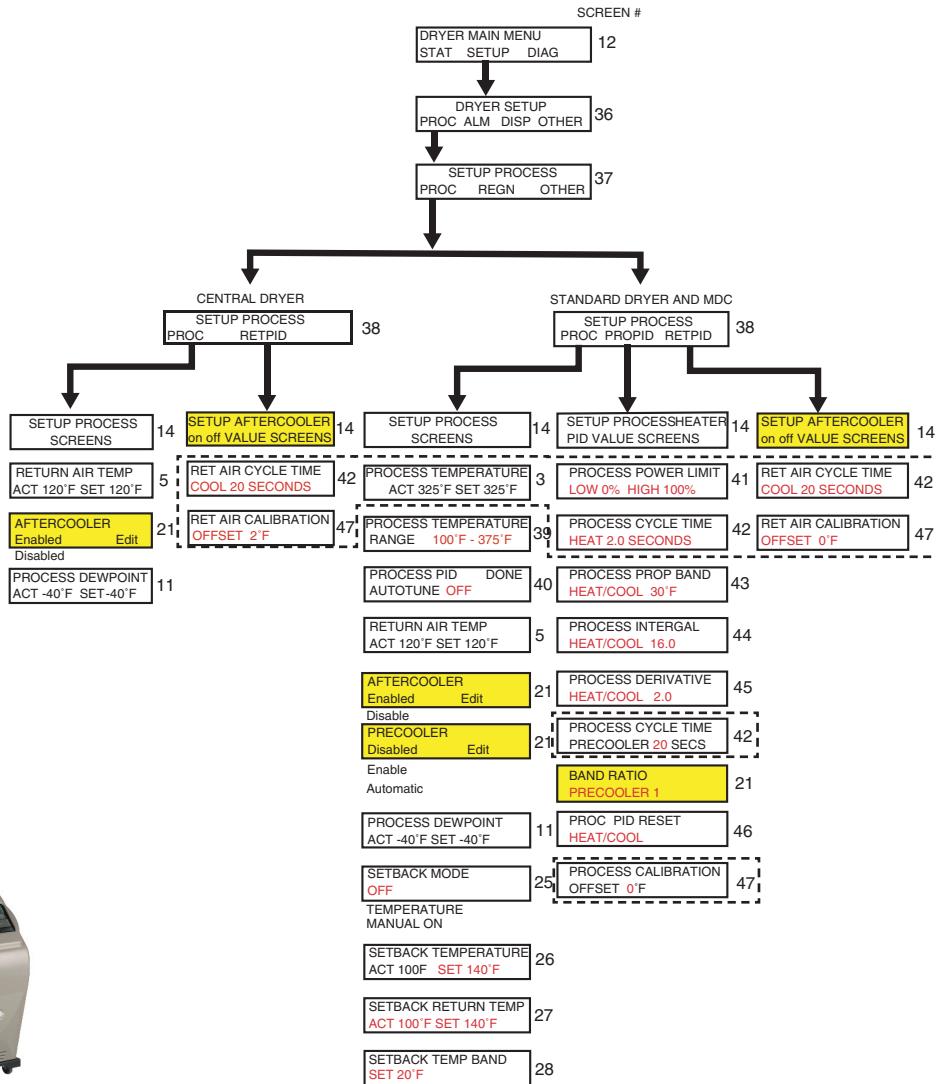

Central

When configured as a central dryer, there is no process heater in the system. Therefore, any function associated with the process heater is not available for central dryer configurations.

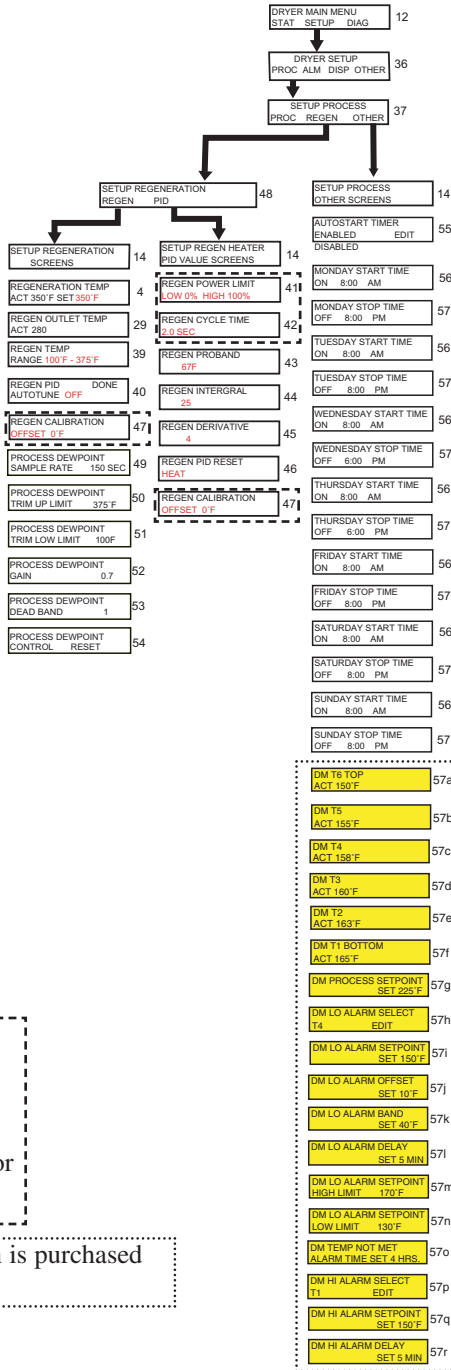

Central

When configured as a central dryer, there is no process heater in the system. Therefore, any function associated with the process heater is not available for central dryer configurations.

When the DM-II monitor option is purchased these screens will be displayed.



Central

When configured as a central dryer, there is no process heater in the system. Therefore, any function associated with the process heater is not available for central dryer configurations.

When the DM-II monitor option is purchased these screens will be displayed.

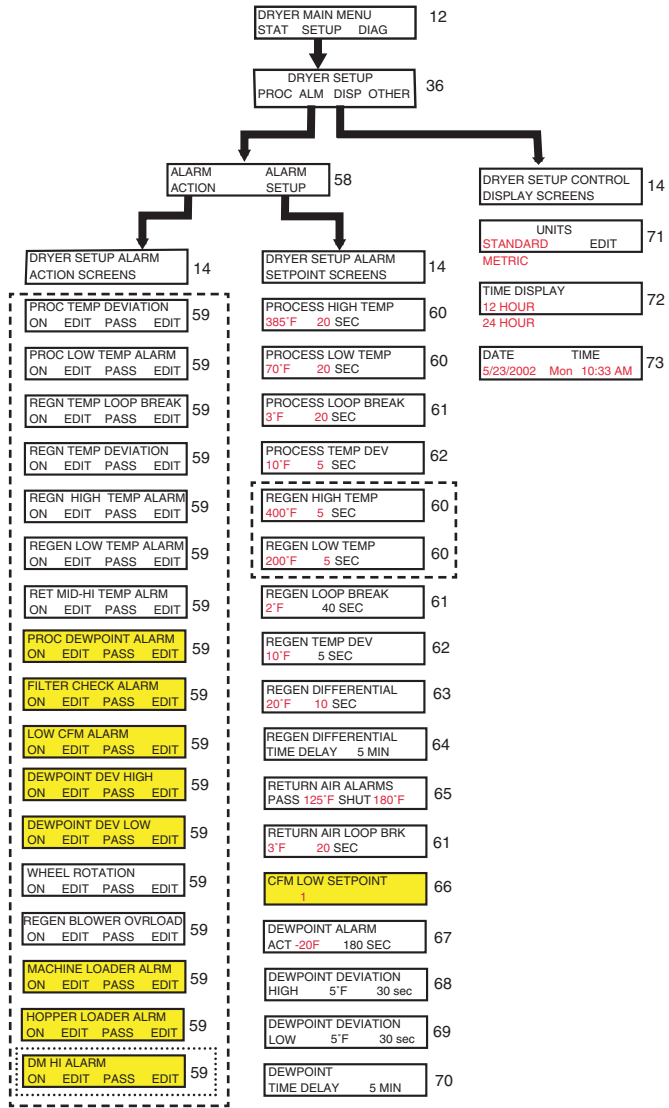

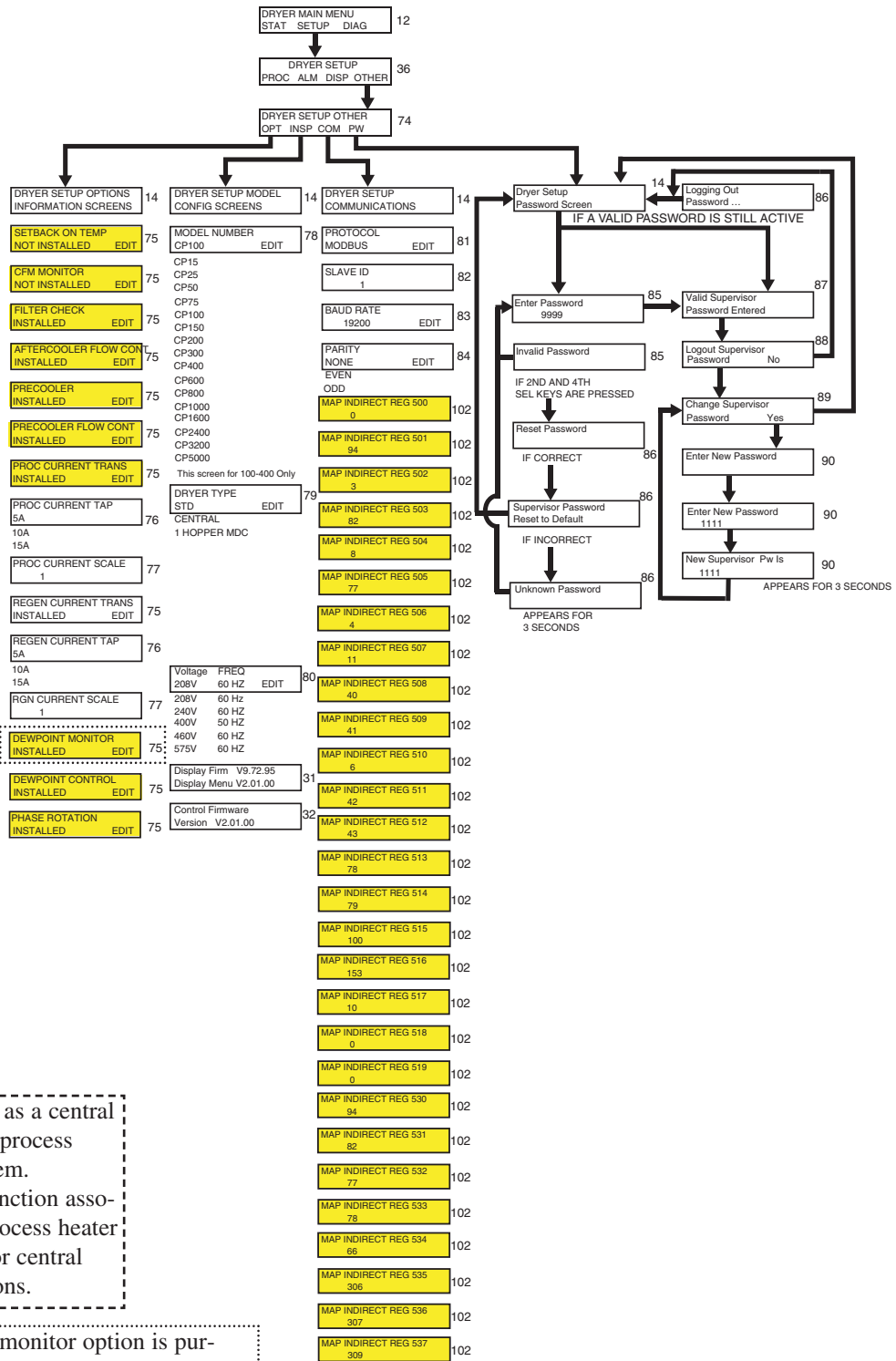

Central

When configured as a central dryer, there is no process heater in the system. Therefore, any function associated with the process heater is not available for central dryer configurations.

When the DM-II monitor option is purchased these screens will be displayed.



Central

When configured as a central dryer, there is no process heater in the system. Therefore, any function associated with the process heater is not available for central dryer configurations.

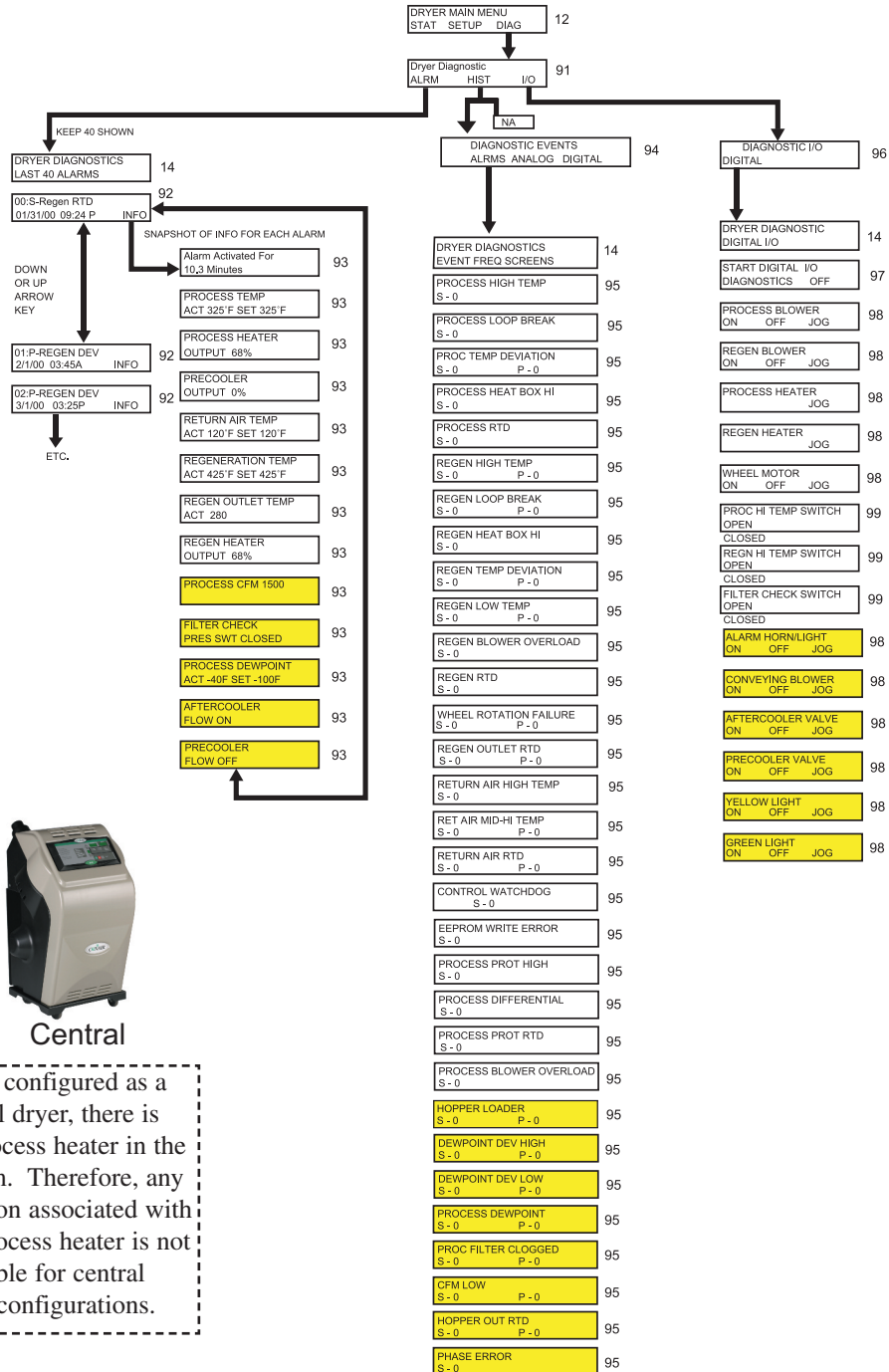

# Control Function Descriptions

## Screen

### SCREEN 1

CONAIR	D100
CV2.21.00	DV2.21.00

### SCREEN 2

MONDAY	
07/22/03	07:59 AM

### SCREEN 3 (Default Screen)

PROCESS TEMPERATURE	
ACT 325°F	SET 325°F

## Function

Once power is turned on, this screen is displayed for 3 seconds. It shows CONAIR and the dryer type on the first line, and the control program version and display program version on the second line.

Once power is turned on and screen 1 is displayed for 3 seconds, this screen is displayed for another 3 seconds. It shows the day of the week on the first line and the date and time on the second line. If this information is not correct, it can be changed under the SETUP, DISP, DATE TIME screen 73.

This is the DEFAULT screen. It shows the process air temperature setpoint and actual temperature measured at the inlet to the drying hopper. The setpoint can be changed by pressing the Select Category button under the Setpoint Value. Once the button is pressed, the setpoint will begin to flash. The numeric keys can be used to enter a new setpoint or the (+) or (-) Increment / Decrement buttons can be used to change the setpoint. Holding the (+) or (-) buttons in will allow the number to ramp up faster the longer the button is held. The "ENTER" key must be pressed to accept the new number. The temperature setpoint range can be changed under the

(continued)



**NOTE:** The supervisory password is required to change certain parameters. Additional information about the password can be on Page 4-37 and under screen 85 on page 4-31.



Central

When supplied for central drying applications, this function is not available.

# Control Function Descriptions (continued)



Central

When supplied for central drying applications, this function is not available.

## Screen

## Function

SCREEN 3 (Default Screen)  
(continued)

PROCESS TEMPERATURE	
ACT 325°F	SET 325°F

SETUP, PROC, PROC, PROC, PROCESS TEMPERATURE RANGE screen 39. The display will return to the default screen from anyplace in the menu structure (with the exception of the AUTOTUNE screens) if nothing is done after 10 minutes. Pressing the “MENU” button from any place in the menu structure will return you to the default screen.

SCREEN 4

REGENERATION TEMP	
ACT 350°F	SET 350°F

Shows the regeneration air setpoint and actual temperature. The setpoint can be changed with the correct password.



**NOTE:** Lowering the regeneration setpoint decreases the capacity of the dryer and normally is not recommended. Use the dewpoint control function instead.

SCREEN 5

RETURN AIR TEMP	
ACT 100°F	SET 100°F

Shows the actual return air temperature measured at the inlet to the process blower. If the optional aftercooler flow control is installed, a setpoint will be displayed on this screen. The setpoint can be changed with the correct password.

# Control Function Descriptions (continued)

## Screen

SCREEN 11 (Dewpoint Control and/or Dewpoint Monitor)

PROCESS DEW POINT	
ACT -47°F	SET -40°F

SCREEN 12 (Main Menu)

DRYER MAIN MENU		
STAT	SETUP	DIAG

SCREEN 13

DRYER STATUS		
PROC	REGEN	OTHER

## Function

This screen will show the actual dewpoint of the process delivery air measured after the desiccant wheel. The dewpoint control will automatically adjust the regeneration temperature to maintain the dewpoint setpoint. Dewpoint control is not active with a -40°F {-40°C} setpoint.



**NOTE:** Dewpoint actual will not be live for approximately 5 to 7 minutes.

This is the dryer MAIN MENU. It can be located by pressing the “MENU” key while at the DEFAULT screen. By pressing the Select Category buttons under the titles, the user goes to STATUS screens, SETUP screens, or DIAGNOSTIC screens.

This is the Dryer Status screen. It can be found by pressing the Select Category button under the word “Stat” on the Main Menu screen 12. Any information under the status section is read only. NO CHANGES can be made from the status sections. The operator can select to see status information for Process, Regeneration, or Other.

# Control Function Descriptions (continued)

## Screen

SCREEN 14

DRYER PROCESS  
STATUS SCREEN

## Function

This is a column title screen. To navigate to screens within a column (reference the flow charts beginning on Page 4-4), the operator must use the scroll buttons, “**Prev**” and “**Next**”. The “**Next**” button will scroll one screen at a time down a list of screens. Once the last screen in the list is displayed the “**Next**” button will return the operator back to this Title screen. When the “**Prev**” button is pressed, it will scroll one screen at a time up the list of screens. Once the title screen is displayed the “**Prev**” button will go up to the next high screen, in this case the Dryer Status screen 13.

SCREEN 15

PROCESS HEATER  
OUTPUT 100%

This is an example of a Heater Output screen. It displays the actual percentage output of the heater, which can also be interpreted as the percentage on time. The on time can be checked by looking at the heater LEDs in the Dryer Status section of the display.

SCREEN 16

PROCESS PROTECTION  
ACT 350°F

The screen shows the process protection actual temperature measured at the process heater outlet.



Central

When supplied for central drying applications, this function is not available.

# Control Function Descriptions (continued)

## Screen

SCREEN 17

TOTAL RUN HOURS  
1250

SCREEN 20 (CFM Monitor Option)

PROCESS CFM 1600

SCREEN 21 (Aftercooler Flow Control Option)

AFTERCOOLER  
ENABLED

SCREEN 21 (Aftercooler Flow Control Option)

AFTERCOOLER  
FLOW ON

SCREEN 21 (Precooler Flow Control Option)

PRECOOLER  
FLOW ON

## Function

This screen shows the total run time in hours that the dryer has been ran since it was new. If the control board was changed during the life of the dryer, this timer will start over.

This is the CFM Monitor screen. It displays the Process CFM and the Cool down CFM. The Process CFM is measured by a differential pressure transducer across the inlet and the outlet of the process blower. Since the Cool down CFM is set with a mechanical orifice, it is a fixed percentage of the measured process reading. The CFM Monitor option must be installed (see screen 75, page 4-28, also see note on this page) for this to appear

This screen shows if the aftercooler is enabled. If the aftercooler is disabled, there will be no setpoint for the Return Air Temperature screen 5. The aftercooler flow control option must be installed (see screen 75, page 4-28, also see note on this page) for this to appear

This screen shows if the control is opening the solenoid valve. The aftercooler flow control option must be installed (see screen 75, page 4-28, also see note on this page) for this to appear.

This screen shows if the control is opening the precooler flow control solenoid valve. The Precooler Flow Control option must be installed (see screen 75, page 4-28, also see note on this page) for this to appear



Central

When configured as a central dryer, there is no process heater in the system. Therefore, any function associated with the process heater is not available for central dryer configurations.



**NOTE:** Screens labeled 75 in the display screen flow chart on page 4-9 are various option installation screens.

# Control Function Descriptions (continued)



**NOTE:** Screens labeled 75 in the display screen flow chart on page 4-9 are various option installation screens.

## Screen

SCREEN 22 (Current Monitor Option)

PROCESS CURRENTS		
84.3 A	84.2 A	84.3 A

SCREEN 23 (Current Monitor Option)

TOTAL POWER
82 KWH

SCREEN 24 (Dewpoint Control and Dewpoint Monitor)

DEWPOINT CONTROL	
AVG	-55°F

SCREEN 25 (Setback on Temperature)

SETBACK MODE
OFF

## Function

This screen shows the measured current on each leg of the 3-phase power going to the process heater. The Current Monitor option (see screen 75, page 4-28, also see note on this page) for this to appear

The screen shows the calculated total power for the dryer. The calculation includes the measured current for the process and regeneration heaters, the control voltage set for the dryer, and pre-determined power consumption values for the blowers and the control. The Current Monitor option (see screen 75, page 4-28, also see note on this page) for this to appear

This screen displays the average dewpoint over the last hour of run time. All packages with DC-2 controls include dewpoint monitor controls.

This screen shows the setting of the setback. (see page 4-42) It can be set to OFF, Temperature, or Manual On. Off turns the setback mode off, and the dryer will not change the process setpoint. The temperature setting tells the control the dryer should go into setback when the hopper outlet temperature reaches the setpoint (Screen 27). The Manual On setting tells the dryer to go into setback now.

# Control Function Descriptions (continued)

## Screen

## Function

SCREEN 26

SETBACK TEMPERATURE	
ACT 140°F	SET 140°F

This screen shows the setpoint the process temperature will go to once the control goes into setback. When the control is in the setback mode, the LED on the dryer display beside SETBACK will illuminate. The actual temperature on the default screen will still show the actual temperature measured at the hopper inlet. The setpoint shown on the default screen will still show the original setpoint.

SCREEN 27

SETBACK RETURN TEMP	
ACT 100°F	SET 140°F

This screen shows the actual temperature measured at the hopper outlet and the setpoint temperature for the air at the hopper outlet that will initiate the control to go into setback.

SCREEN 28

SETBACK TEMP BAND	
SET 20°F	

This shows how much lower the hopper outlet temperature must drop from the Setback Return Temperature setpoint (screen 27) before the dryer control should restore the original process setpoint.

SCREEN 29 (Regeneration Outlet Temperature)

REGEN OUTLET TEMP	
ACT 280	

This screen shows the actual temperature measured at the regeneration outlet of the wheel manifold.

# Control Function Descriptions (continued)

## Screen

## Function

### SCREEN 30

MODEL	CP100
480 V	60 Hz

This screen shows the model number, voltage, and frequency for which the dryer control is setup. These values can be changed with the proper password see page 4-31 (screen 85) under SETUP, OTHER, INSP, Model # (screen 78), and Voltage FREQ (screen 80).

◆ **Tip:** This information is important to know when ordering a control board.

### SCREEN 31

DISPLAY FIRM	V2.21.00
DISPLAY MENU	V2.21.00

This screen shows the current versions of program for the Display Firmware and Menus.

◆ **Tip:** This information is important to know when ordering a display board.

### SCREEN 32

CONTROL FIRMWARE	
VERSION	V2.21.00

This screen shows the current versions of program for the Control Firmware.

### SCREEN 33

AUTOSTART COUNT DOWN	
1 DAYS	23:05:53

If the dryer is set with an auto start time, this screen will appear and show the amount of time remaining before the dryer will automatically start. The LED on the front of the display, beside the word Auto Start, will flash if the dryer is set to start automatically. The auto start feature can be programmed under SETUP, PROC, PROC, OTHER (screens 55, 56, 57). The dryer can be set to automatically start and stop each day.

### SCREEN 34

AUTOSTOP COUNT DOWN	
3 DAYS	11:04:23

If the dryer is set to auto stop, this screen will appear and show the amount of time remaining before the dryer will automatically stop. The auto stop feature can be programmed under SETUP, PROC, PROC, OTHER (screens 55, 56, 57). The dryer can be set to automatically start and stop each day.

# Control Function Descriptions (continued)

## Screen

SCREEN 35

PANEL INSIDE TEMP ACT 100°F
--------------------------------

SCREEN 36

DRYER SETUP			
PROC	ALM	DISP	OTHER

SCREEN 37

SETUP PROCESS		
PROC	REGEN	OTHER

SCREEN 38

SETUP PROCESS		
PROC	PROPID	RETPID

SCREEN 39

PROCESS TEMPERATURE	
RANGE	100°F - 450°F

## Function

This screen shows the temperature inside the control enclosure. It is measured at the lower right corner of the control board.

This is the Dryer Setup screen. It can be found by pressing the Select Category button under the word Setup on the Main Menu (screen 12). By pressing the Select Category buttons under the titles, the user can select to see setup information for Process, Alarms, Display, or Other.

This is the Setup Process screen. It can be found by pressing the Select Category button under the word "Proc" on the Dryer Setup (screen 36). By pressing the Select Category buttons under the titles, the user can select to see setup information for Process, Regeneration, or Other.

This is the second Setup Process screen. It can be found by pressing the Select Category button under the word "Proc" on the Setup Process screen (37). By pressing the Select Category buttons under the titles, the user can select to see setup information for Process, Process PID, or Return Air PID if the aftercooler flow control is installed. Note: When configured as a central dryer, you will not see the process PROPID.

This screen shows the allowable temperature range for setpoint temperatures. With the proper password, see page 4-31, screen 85. This range can be narrowed.

 **NOTE:** Conair is not responsible for damage caused by excessively high drying setpoints that are not in accordance with your drying material recommendations.

 **NOTE:** Software may allow the Process temperature setpoint limit up to 450°F, however Conair does not recommend a setpoint limit over 375°F {191°C} due to nuisance alarms.

 **NOTE:** To avoid nuisance alarms Conair recommends that the low setpoints to be set to 150°F {66°C} or above.

# Control Function Descriptions (continued)

## Screen

SCREEN 40

PROCESS PID	DONE
AUTOTUNE	OFF

and

REGEN PID	DONE
AUTO	

## Function

Before running an autotune, set the set-point to the desired temperature you would like the control to autotune to on screen 3 for process and screen 4 for regeneration. Screen 47 shows the autotune function for the selected heater. The dryer must not be running to initiate an autotune. The autotune should be started from a cold start to work best. With the proper password, (see page 4-31, screen 85) press the Select Category button under the word Off. Once selected, the word should start to blink. Press the (+) or (-) button to toggle the Off to On and then press the **“ENTER”** key to start the autotune. The display will show "Wait" then "Heat" then "Done" when it is complete. Pressing **“STOP”** during an autotune will cancel the autotune and not change PID values. The PID values can be set back to factory defaults by going to the Reset screen (46).

**NOTE:** Screens 41, 42, 43, 44, 45, 46 and 47 apply to process and regeneration.



Central

When configured as a central dryer, there is no process heater in the system. Therefore, any function associated with the process heater is not available for central dryer configurations.

SCREEN 41

PROCESS POWER LIMIT	
LOW 2%	HIGH 80%

This screen shows the power output range for the heater. It is set by default to 0% for the low and 100% for the high.

SCREEN 42

PROCESS CYCLE TIME	
HEAT 2.0 SECONDS	

This screen shows the PID cycle time for the heater "Heat", or with a precooler "Cool". This time value is the time for one on/off cycle. For example, with a heater running at 50% and the cycle time set at 2 seconds the heater would be on 1 second and off 1 second.

SCREEN 43

PROCESS PROP BAND	
HEAT/COOL 30°F	

This screen shows the Proportional Band value for the PID loop.

# Control Function Descriptions (continued)

## Screen

SCREEN 44

PROCESS INTEGRAL	
HEAT/COOL	16.0

SCREEN 45

PROCESS DERIVATIVE	
HEAT/COOL	2.0

SCREEN 46

PROC PID RESET	
HEAT/COOL	

SCREEN 47

PROCESS CALIBRATION	
OFFSET	2°F

SCREEN 48

SETUP REGENERATION	
REGEN	PID

SCREEN 49

PROCESS DEWPOINT	
SAMPLE RATE	150 SEC

## Function

This screen shows the integral value for the PID Loop.

This screen shows the derivative value for the PID Loop.

With the proper password, (see page 4-31, screen 85) the PID values can be reset back to the factory default settings. Press the Select Category button under the word Heat to reset the values for the process heater, or Cool to reset the values for the pre-cooler flow control when this option is installed.

This screen shows the temperature offset for the RTD. This screen is used if the process readout needs to be calibrated.

This is the Setup Regeneration screen. It can be found by pressing the Select Category button under the word Regen on the Setup Process screen (37). By pressing the Select Category buttons under the titles, the user can select to see setup information for Regeneration or Regeneration PID.

This is the amount of time the control waits before checking the dewpoint value after making a change. This time value gives the system time to respond to a process change.

**NOTE:** Screens 41, 42, 43, 44, 45, 46 and 47 apply to process and regeneration.



Central

When configured as a central dryer, there is no process heater in the system. Therefore, any function associated with the process heater is not available for central dryer configurations.

# Control Function Descriptions (continued)

## Screen

SCREEN 50

PROCESS DEWPOINT	
TRIM UP LIMIT	375°F

SCREEN 51

PROCESS DEWPOINT	
TRIM LOW LIMIT	100°F

SCREEN 52

PROCESS DEWPOINT	
GAIN	0.7

SCREEN 53

PROCESS DEWPOINT	
DEADBAND	1

SCREEN 54

PROCESS DEWPOINT	
CONTROL RESET	

SCREEN 55

AUTO START TIMER	
ENABLED	EDIT

## Function

This is the maximum value the dewpoint control can set the regeneration temperature to achieve the desired dewpoint.

This is the minimum value the dewpoint control can set the regeneration temperature to achieve the desired dewpoint.

This is the proportional gain value for the dewpoint control.

This is the deadband range. If the actual dewpoint value is within this range of the dewpoint setpoint, the control will not make a change to the regeneration temperature.

This will reset the dewpoint control back to the factory default values.

This screen is used to enable or disable the auto start function. If the function is enabled, the dryer can be started or stopped once each day. The start and stop times and days can be set on screens 56 and 57.

# Control Function Descriptions (continued)

## Screen

## Function

SCREEN 56

MONDAY START TIME	
ON	8:00 AM

This is the auto start screen for the first day of the week. Each day has a screen similar to this. By pressing the Select Category button under On or Off, the dryer can be set to start on Monday. The start time can be set by pressing the Select Category button under time and entering a new time on the numeric keypad. The AM / PM can be changed only after a time value has been entered. The (+) button will set PM and the (-) button will set AM. The “ENTER” key must be pressed to lock in the new time. The dryer can be manually started at anytime. If the auto start time runs out and the dryer has been manually started nothing will happen.

SCREEN 57

MONDAY STOP TIME	
ON	8:00 PM

This is the auto stop screen for the first day of the week. Each day has a screen similar to this. By pressing the Select Category button under On or Off, the dryer can be set to stop on Monday. The stop time can be set by pressing the Select Category button under time and entering a new time on the numeric keypad. The AM / PM can be changed only after a time value has been entered. The (+) button will set PM and the (-) button will set AM. The “ENTER” key must be pressed to lock in the new time. If the auto stop time runs out and the dryer has already been manually stopped nothing will happen. If the dryer was auto started on Monday morning and the Monday auto stop is set to off, the dryer will continue running until it hits a day of the week when the auto stop is set to On. At that time the dryer will turn off.

 **NOTE:** If you purchased the DM-II (Drying Monitor Option), there will be additional screens present in this area. See the DM-II Appendix for information pertaining to the control function descriptions for the DM-II.

# Control Function Descriptions (continued)

## Screen

## Function

SCREEN 58

ALARM	ALARM
ACTION	SETUP

This is the alarm action and setup screen. With the proper password, (see page 4-31, screen 85) the Select Category button can be pressed under Alarm Action or Alarm Setup. Alarm Action screens can be used to change whether an alarm is Off, Passive, or Shutdown (screen 59). Alarm Setup screens can be used to change alarm setpoints and delay times. (screens 60-70)

SCREEN 59

PROC TEMP DEVIATION			
ON	EDIT	PASS	EDIT

This is an example of the Alarm Action screens. With the proper password, (see page 4-31, screen 85) some alarms can be turned on or off by either pressing the Select Category button under the word Edit, or by pressing the Select Category button under the word On or Off. Once the word begins to blink, the (+) or (-) keys will change the setting. The **“ENTER”** key must be pressed to lock in the value. The same sequence works for the Pass or Shutdown words. “Pass” or Passive means the alarm will not shut the dryer down but the alarm will be logged in the Dryer Diagnostics Alarm Log. A “Shut” means Shutdown, in which case the dryer would shutdown if the alarm occurs.



Central

When supplied for central drying applications, this function is not available.

SCREEN 60

PROCESS HIGH TEMP	
250°F	1 SEC

This is an example of an Alarm Setup screen that has a minimum or maximum temperature. With the proper password, (see page 4-31, screen 85, refer to password) the temperature setpoint can be changed as well as how long the dryer has to stay at that temperature before alarming.



# Control Function Descriptions (continued)

## Screen

SCREEN 66 (CFM Monitor Option)

CFM LOW SETPOINT 1430
--------------------------

SCREEN 67 (Dewpoint Monitor or Dewpoint Control)

DEWPOINT ALARM ACT -20°F      180 SEC
------------------------------------------

SCREEN 68

DEWPOINT DEVIATION HIGH    5°F      30 SEC
-----------------------------------------------

SCREEN 69

DEWPOINT DEVIATION LOW 5°F      30 SEC
-------------------------------------------

## Function

This screen shows the low CFM setpoint. The default is 1 CFM. The default can be changed with the proper password (see page 4-31, screen 85).

This screen shows the alarm setpoint for a Dewpoint alarm. With the proper password, it can be changed (see page 4-31, screen 85). The defaults are -3°F {-5°C} for 180 seconds. If the control senses -3°F {-5°C} or higher for 180 seconds, the dryer will alarm.

This is the dewpoint high deviation alarm value. With the proper password, it can be changed (see page 4-31, screen 85). When in dewpoint control, if the actual dewpoint goes above the setpoint in screen 67 for the set amount of time, the dryer will alarm “Dewpoint Deviation High”.

This is the dewpoint low deviation alarm value. With the proper password, it can be changed (see page 4-31, screen 85). When in dewpoint control, if the actual dewpoint goes below the setpoint by this value for this amount of time, the dryer will alarm “Dewpoint Deviation Low”.

# Control Function Descriptions (continued)

## Screen

## Function

### SCREEN 70

DEWPOINT		
TIME	DELAY	5 MIN

This is the amount of time from start-up the dryer is allowed to run before the control will try to control the dewpoint. Five minutes is the default. This gives the dryer time to warm up and reach a steady state. It can be changed with the proper password (see page 4-31, screen 85).

### SCREEN 71

UNITS		
STANDARD		EDIT

This screen shows the units the dryer will display. It can be changed with the proper password (see page 4-31, screen 85) to either Standard or Metric. Press the Select Category button below the word Edit to change the setting and press the **“ENTER”** key to lock in the value.

### SCREEN 72

TIME DISPLAY	
12 HOUR	

This screen shows the time unit the dryer will display. It can be changed with the proper password (see page 4-31, screen 85) to either 12 hour (AM / PM Clock) or 24 hour (Military Time). Press the Select Category button below the words 12 hour to change the setting and press the **“ENTER”** key to lock in the value.

### SCREEN 73

DATE	TIME
10/25/2004 MON	10:33 AM

This screen shows the date and time. With the proper password, (see page 4-31, screen 85) the date and time can be changed.

# Control Function Descriptions (continued)

## Screen

SCREEN 74

DRYER SETUP OTHER			
OPT	INSP	COM	PW

SCREEN 75

CFM MONITOR	
NOT INSTALLED	EDIT

SCREEN 76

PROCESS CURRENT	TAP
5 A	

SCREEN 77

PROCESS CURRENT SCALE
1

## Function

This is the Dryer Setup Other screen. It can be found by pressing the Select Category button under the word Other on the Dryer Setup Screen (36). By pressing the Select Category buttons under the titles, the user can select to see setup information for Options, Inspection, Communications, or Password.

This is an example of an Option Installation screen. With the proper password (see page 4-31, screen 85) and hardware installed, an option can be turned on by pressing the Select Category screen under the word Edit. This will change an option from Not Installed to Installed. The “**ENTER**” key must be pressed to lock in the change. Once an option is installed, there may be additional screens that show in the menu structure that need to be setup. Please reference the option installing section of this manual.

This screen is used with the current monitor option and tells the control which tap is used on the current sensing board (5A, 10A, or 15A).

This screen is used with the current monitor option and is used to properly scale the reading.



**NOTE:** Screens labeled 75 in the display screen flow chart on page 4-9 are various option installation screens.

# Control Function Descriptions (continued)

## Screen

## Function

### SCREEN 78

MODEL NUMBER	
CP100	EDIT

This screen further defines the dryer type to a model number. Based on the dryer type, the selections on this menu will change. Your dryer should be configured from the factory. However, if the controls were changed from one machine to another type of machine, the control may need to be reconfigured. With the proper password, (see page 4-31, screen 85) the Model Number can be changed by pressing the Select Category button under the word Edit. The **“ENTER”** key must be pressed to lock in the selection.

### SCREEN 79

DRYER TYPE	
STD	EDIT

This screen is used to tell the control what dryer it is controlling. The selections are Standard, Central or 1 Hopper MDC. Your dryer should be configured from the factory. However, if the controls were changed from one machine to another type of machine, the control may need to be reconfigured. With the proper password, (see page 4-31, screen 85) the dryer type can be changed by pressing the Select Category button under the word Edit. The **“ENTER”** key must be pressed to lock in the selection.

### SCREEN 80

VOLTAGE	FREQ	
208 V	60 HZ	EDIT

This screen defines the voltage and frequency at which the dryer will be running. This setting should match the electrical label on the side of the control box. Your dryer should be configured from the factory. However, if the controls were changed to run on another voltage, this screen may need to be reconfigured. With the proper password, (see page 4-31, screen 85) the Voltage Freq can be changed by pressing the Select Category button under the word Edit. The **“ENTER”** key must be pressed to lock in the selection.

## Control Function Descriptions (continued)

### Screen

#### SCREEN 81 Communications

PROTOCOL	
DEVICENET	EDIT

#### SCREEN 82 Communications

SLAVE ID	
1	EDIT

#### SCREEN 83 Communications

BAUD RATE	
9600	EDIT

#### SCREEN 84 Communications

PARITY	
NONE	EDIT

### Function

This screen shows the communications protocol. Modbus, DeviceNet, Ethernet or SPI are available. This is set at the factory. If adding to an existing dryer, the communications protocol can be changed with the proper password (see page 4-31, screen 85).

This screen shows the Slave ID number. The ID number can be changed with the proper password (see page 4-31, screen 85) by pressing the Select Category button below the word Edit and entering a value on the keypad or scrolling to the desired value using the Adjust Setpoint keys. The **“ENTER”** key needs to be pressed to lock in the new number.

This screen shows the baud rate. The baud rate can be changed with the proper password (see page 4-31, screen 85). Press the Select Category key below the word Edit and enter a value on the keypad or scroll to the desired value using the Adjust Setpoint keys.

This screen shows the parity. The parity can be changed with the proper password (see page 4-31, screen 85) to Even, Odd, or None by pressing the Select Category button below the word Edit. The **“ENTER”** key needs to be pressed to lock in the new number.

# Control Function Descriptions (continued)

## Screen

## Function

### SCREEN 85

ENTER PASSWORD  
0210

This screen shows the password entry screen. By pressing the Select Category button under the word “Press Here”, the user can enter a password by using the keypad. Once a password has been entered the “**ENTER**” key must be pressed. If the password is valid, the display will show screen 87. If the password was incorrect, it will display "Invalid Password Try Again" and go back to the Enter Password screen. The default supervisor password is 0210. The supervisor can change this password by going to screen 89.

### SCREEN 86

RESET PASSWORD  
PRESS HERE

This is the Reset Password screen. It will only be shown when the second and fourth Select Category buttons are pressed at the same time when at screen 85. By pressing the Select Category button under the word Press Here, the user can enter the default password by using the keypad. Once the default password has been entered, the “**ENTER**” key must be pressed. This will change the password back to the factory default password (see page 4-31, screen 85). If the password has been changed see screens 89 and 90

### SCREEN 87

VALID SUPERVISOR  
PASSWORD ENTERED

This is the display screen that appears when a valid password has been entered. Pressing the Previous button will take you screen 14. Pressing “**NEXT**” will take you to screen 88.

# Control Function Descriptions (continued)

## Screen

SCREEN 88

LOGOUT SUPERVISOR	
PASSWORD	YES

SCREEN 89

CHANGE SUPERVISOR	
PASSWORD	YES

SCREEN 90

ENTER NEW PASSWORD
PRESS HERE

SCREEN 91

DRYER DIAGNOSTIC				
ALRM	EVENT	HIST	I/O	

## Function

This is the password logout screen. If nothing is done, the password will automatically be logged out after 30 minutes. To logout, use the Select Category button under the word Yes/No. Setting it to “yes” and hitting the “**ENTER**” Key will change the display to "Logging Out Password". Screen 86 will display for 3 seconds then will automatically go to screen 14.

This screen allows the supervisor to change the password. To change the password, use the Select Category button under the word, Yes/No. Setting it to “yes” and hitting the “**ENTER**” Key will change the display to screen 90. If the user does not want to change the password, by pressing the “**NEXT**” key the control will return to the Dryer Setup Password screen 14.

This screen shows the password entry screen. By pressing the Select Category button under the word Press Here, the user can enter a new password by using the key pad. Once a new password has been entered the “**ENTER**” key must be pressed. The display will show the new password for 3 seconds then return to the Change Supervisor Password (screen 89). To exit, press the “**NEXT**” key and the control will return to the Dryer Setup Password Screen.

This is the Dryer Diagnostic screen. It can be found by pressing the Select Category button under the word Diag on the Dryer Main Menu screen 12. By pressing the Select Category buttons under the titles, the user can select to see diagnostic information for Alarms, Alarm History, or Inputs and Outputs.

# Control Function Descriptions (continued)

## Screen

SCREEN 92

00:S-REGEN RTD	
1/31/00 09:24 P	INFO

SCREEN 93

ALARM ACTIVATED FOR
10.3 MINUTES

SCREEN 94

DIAGNOSTIC EVENTS		
ALARMS	ANALOG	DIGITAL

SCREEN 95

PROCESS HIGH TEMP	
S - 0	P - 0

## Function

This is an example of one of the alarm history screens. The first two numbers of the first line show what alarm you are viewing in the list. This example is the first alarm in the list 00. The letter after the : P or : S shows if the alarm was a passive or shutdown alarm. The second line shows the date and time when the alarm occurred. By pressing the Select Category button under the word Info, the display can show a number of screens that are a snapshot of information that was happening when the alarm occurred.

This is an example of one of the Information screens for an alarm. This is the first screen under Info shown on screen 92. It shows how long the alarm was active. The time shown is from when the alarm occurred until the alarm was acknowledged and cleared. The “Next” button can be pressed while at this screen to see other items in the list of snapshot info that was happening when the alarm occurred.

This is the Dryer Diagnostic screen. It can be found by pressing the Select Category button under the word Hist on the Dryer Diagnostics screen (91). By pressing the Select Category buttons under the titles, the user can select to see diagnostic information for Alarms.

This is an example of the Event Frequency screens. This shows the number of times an alarm has occurred. By pressing the “Next” key in this section, the user can see info for all alarms. The “S” indicates how many times it was a shutdown alarm and the “P” indicates how many times it was a passive alarm.

# Control Function Descriptions (continued)

## Screen

SCREEN 96

DIAGNOSTIC I/O
DIGITAL

SCREEN 97

START DIGITAL I/O	
DIAGNOSTICS	OFF

SCREEN 98

PROCESS BLOWER		
ON	OFF	JOG

SCREEN 99

PROC
OPEN

SCREEN 102

MAP INDIRECT REG 500
0

## Function

This is the Diagnostic I/O screen. It can be found by pressing the Select Category button under the word I/O on the Dryer Diagnostics screen (91). By pressing the Select Category button under Digital, the user can access the digital outputs (screen 98) and view the status of the digital inputs (screen 99). The analog diagnostic I/O function is not used.

This screen is used to enter the diagnostic mode where outputs can be turned on (screen 98). Note that the dryer **MUST NOT BE** running to enter diagnostics.

This is an example of one of the digital outputs that can be manually energized. All screens in this section only work when the dryer is not running and is in “stand-by”. The outputs can be turned on, turned off, or energized for a 3-second jog (automatically turned on for 3 seconds then turned off). The process and regeneration heaters can only be jogged for 3 seconds, and the index motor, if jogged, will rotate the wheel for 3 seconds. If the “**STOP**” button is pressed at any time during this testing, the output will stop immediately.

This is an example of one of the digital inputs screens. This will show if the input is open or closed.

These parameters map which internal variables are accessible from the user communication port on the DC-2 operator display. A default set of variables has been chosen that represent the most important variables for the majority of uses. These values should not be changed except under the direction of Conair Engineering or Service.

# To Start Drying

- 1 Make sure there is material in the hopper.**
- 2 Turn on the main power to the dryer.** Make sure the dryer's disconnect dial is in the "ON" position. This powers up the control and the display lights will illuminate.
- 3 Set the drying temperature.** Press the appropriate Select Category button then the Adjust Setpoint (+) or (-) buttons or enter your drying temperature on the numeric keypad and then press "ENTER".



 **NOTE:** When changing a setpoint use the Select Category Key directly below the value to be changed. Once pressed the value will blink, then use the keypads or (+) (-) adjustment set-points to enter the new value. Then press "ENTER" for the new value to be recognized.



Central

When configured as a central dryer, the drying temperature cannot be set since there is no process heater in the system.

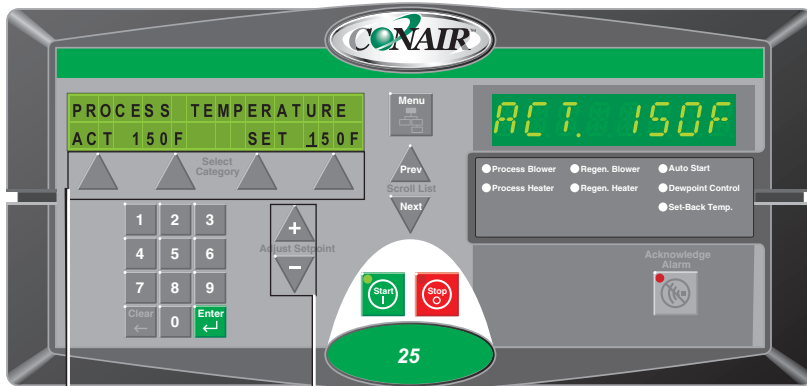

Select Category buttons

Setpoint adjustment buttons

(continued)

## To Start Drying (continued)

### 4 Press the START button.



If everything is installed correctly:

- The green light on the start button will illuminate.
- The process and regeneration blowers turn on and the display LEDs will illuminate.
- The process and regeneration heaters turn on and the display LEDs will illuminate.
- The desiccant wheel starts turning.



Central

- The green light on the start button will illuminate.
- The process and regeneration blowers turn on and the display LEDs will illuminate.
- The regeneration heater turns on and the display LED will illuminate.
- The desiccant wheel starts turning.

## To Stop Drying

### 1 Press the STOP button. The Stop LED blinks red.



- The blowers continue running for a few minutes to cool the heaters.

### 2 Be sure to disconnect and lockout the main power if you have stopped the dryer to perform maintenance or repair.



**IMPORTANT:** Do not use the main power switch to stop the dryer. Turning off power to the control and dryer during normal operation prevents the necessary cool-down period, and can trigger the shutdown/high temperature alarm during your next drying cycle.



**Caution:** Improper shut down can cause damage to your dryer.

# How to Use the Supervisor's Password

The supervisor's password must be entered before you can use or make changes to some screens on the dryer control. To enter the supervisor password:

- 1 Go to screen 12 and press the **Select Category** button under "Setup".



- 2 This will take you to screen 36. **On Screen 36, press the Select Category button** under "Other".

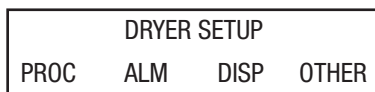

- 3 This will take you to screen 74. **On Screen 74, press the Select Category button** under "PW".

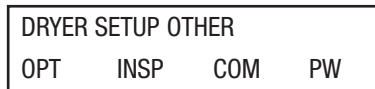

This will take you to screen 14.

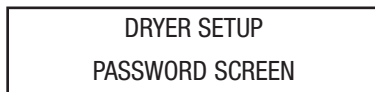

- 4 **On Screen 14, press the Scroll List Next button.** This will take you to screen 85.



(continued)

# How to Use the Supervisor's Password (continued)

- 5 This is the screen where you will need to enter the supervisor's password.**  
The default supervisory password is 0210. Enter this number to make changes to screens where the supervisor's password is necessary to use or change a function of the dryer.

ENTER PASSWORD 0210
------------------------

Be sure to push **“Enter”** after entering the password. If the password is entered successfully, screen 87 will be displayed.

VALID SUPERVISOR PASSWORD ENTERED
--------------------------------------

You can now make changes to screens where the supervisor's password is required. Once the desired parameter has been changed, follow the previous steps to go to screen 88 (see the flow chart on page 4-4).

LOGOUT SUPERVISOR PASSWORD YES
-----------------------------------

Push the Select Category button under “No”. Once it begins to flash, push the Adjust Setpoint button to display “Yes”, then push **“Enter”**. Push the Menu button to return to the main display.



**NOTE:** The supervisor's password can be changed by going to screen 89, see page 4-4, for the map of the screens. See page 4-32, screen 89 for additional information on changing the supervisory password.

# Using the Auto Start Timer

You can set the dryer to start and stop automatically using the Auto Start and Auto Stop functions. The Supervisor Password is necessary to use this function.

 **NOTE:** To use the Auto Start or Auto Stop Timer, you must have the Auto Start function enabled (see screen 55, page 4-22).

## Programming Auto Start

The Auto Start time can be programmed using the Auto Start Countdown screen. This screen can be accessed under the SETUP, PROC, and OTHER screens **from the “Dryer Main Menu”, screen 12:**

SCREEN 36

Dryer Setup			
Proc	Alm	Disp	Other

SCREEN 37

Setup Process		
Proc	Regen	Other

SCREEN 56

MONDAY START TIME	
ON	8:00 AM

Once the Auto Start day and time has been programmed, the Auto Start Countdown screen (screen 33) will show the amount of time remaining before the dryer will automatically start. The LED on the front of the display beside the word Auto Start will flash if the dryer is set to start automatically. The dryer can be set to automatically start each day.

## Programming Auto Stop

The Auto Stop time can be programmed using the Auto Stop Countdown screen. This screen can be accessed under the SETUP, PROC, and OTHER screens **from the “Dryer Main Menu”, screen 12:**

SCREEN 36

Dryer Setup			
Proc	Alm	Disp	Other

SCREEN 37

Setup Process		
Proc	Regen	Other

SCREEN 57

MONDAY STOP TIME	
ON	8:00 PM

Once the Auto Stop day and time has been programmed, the Auto Stop Countdown screen (screen 34) will show the amount of time remaining before the dryer will automatically stop. The dryer can be set to automatically stop each day.



Central

When configured as a central dryer, the high setpoint limits can not be set since there is no process heater in the system.

**NOTE:** Software may allow the Process temperature setpoint limit up to 450°F, however Conair does not recommend a setpoint limit over 375°F {191°C} due to nuisance alarms.

**NOTE:** To avoid nuisance alarms Conair recommends that the low setpoints to be set to 150°F {66°C} or above.

## Setting the High Setpoint Limit

You can protect your drying process by preventing someone from entering process temperatures above or below an acceptable level for the material. You can also set the high and low limits equal to the process temperature to prevent accidental or unauthorized changes to the setting during operation.

- 1 Turn on the main power to the dryer.
- 2 Use the Scroll keys to access the **SETUP, PROC, PROC, and PROC** screens under the **Dryer Main Menu, screen 12.**

SCREEN 36

DRYER SETUP			
PROC	ALM	DISP	OTHER

SCREEN 37

SETUP PROCESS		
PROC	REGEN	OTHER

SCREEN 38

SETUP PROCESS		
PROC	PROPID	RETPID

SCREEN 14

DRYER PROCESS	
SETUP SCREEN	

- 3 Then select the **PROCESS TEMPERATURE RANGE** screen.

SCREEN 39

PROCESS TEMPERATURE	
RANGE	100 F - 450 F

- 4 The **PROCESS TEMPERATURE RANGE** screen shows the **allowable temperature range for setpoint temperatures.** With the supervisory password this range can be narrowed. See page 4-31, screen 85.

# Using the Dewpoint Monitor and Dewpoint Control

Your dryer is equipped with a dewpoint monitor and dewpoint control features. You can choose to use it as a monitor only device, or to maintain a steady dewpoint that you select with the dewpoint control. Dewpoint control will vary the regeneration air temperature to condition the desiccant to the level necessary to maintain the desired dewpoint.

## Dewpoint Monitor

 **NOTE:** The supervisor's password is necessary. Please refer to the "Using the Supervisor's Password" section on page 4-37.

From "Dryer Main Menu", select "Setup, Other OPT" to get to the "Dryer Setup Options Information" (screen 14, page 4-14). Proceed to screen 75 (page 4-28). "Dewpoint Monitor" must be set to "Installed" and "Dewpoint Control" set to "Not Installed". Screen 11 (page 4-13) will display the actual dewpoint readout.

## Dewpoint Control

 **NOTE:** The supervisor's password is necessary. Please refer to the "Using the Supervisor's Password" section on page 4-37.

From "Dryer Main Menu", select "Setup, Other OPT" to get to the "Dryer Setup Options Information" (screen 14, page 4-14). Proceed to screen 75 (page 4-28). "Dewpoint Control" must be set to "Installed". "Dewpoint Monitor" can be set to "Installed" or "Not Installed". Screen 11 (page 4-13) will display the actual dewpoint and the dewpoint setpoint the dryer is to maintain.

 **NOTE:** Dewpoint control is inactive when the dewpoint setpoint is  $-40^{\circ}\text{ F}$  {  $-40^{\circ}\text{ C}$  }.

 **NOTE:** For more information concerning specific dewpoint control screens, see Control Function Descriptions, page 4-11.

## Using the Setback Feature



Central

When supplied for central drying applications, the W Series Dryer does not have setback capabilities. Therefore the setback function is not applicable.

The DC-2 comes standard with setback installed, but disabled. You can choose to set the mode to "Off", "Temperature", or "Manual On". Refer to the Control Function Descriptions later in this section for more detailed information.

This feature is designed to save you money on energy costs and help to keep you from over drying your material.

### **This is how setback operates when the control setback mode is set on Temperature.**

The control monitors the temperature of the air exiting the drying hopper. If that temperature reaches a customer-entered setpoint (Screen 27), the delivery process air temperature will automatically setback to a customer-entered setpoint (Screen 26). Then, if the air exiting the drying hopper drops below the customer-entered temperature on Screen 27 by an amount greater than what is shown on Screen 28, the process temperature will automatically reset back to the original value (Screen 3).

### **To Activate Setback:**

Screen 25 is used to set the setback mode. Screen 25 can also be used to change or monitor the setback mode while in operation.

- 1 Reference the flow chart starting on Page 4-4** and follow the Menu Tree Path to access Screen 25.
- 2 Set the Setback mode.** "Off" turns the setback mode off, and the dryer will not change the process setpoint. The "Temperature" setting tells the control the dryer should go into setback when the hopper outlet temperature reaches the setpoint on Screen 27.
- 3 Once you have selected your setback mode,** go to Screen 26 and set the setback process temperature. This screen shows the setpoint at which the process temperature will go to once the control goes into setback. Note: Make sure your setback temperature is approximately 40° F above your return air temperature when using this feature. When the control is in the setback mode, the LED on the dryer display beside SET-BACK will illuminate. The actual temperature on the default screen will still show the actual temperature measured at the hopper inlet. The setpoint shown on the default screen will still show the original setpoint.

# Using the Setback Feature

(continued)

- 4 Access Screen 27 and set the setback return temperature** for the air exiting the hopper. This screen shows the actual temperature measured at the hopper outlet and the setpoint temperature for the air at the hopper outlet that will initiate the control to go into setback.
- 5 Access Screen 28 and set the setback temperature band.** This screen shows how much lower the hopper outlet temperature must drop from the Setback Return Temperature setpoint (Screen 27) before the dryer control should restore the original process setpoint.

## Setback Feature Guidelines

Careful selection of setpoint values in these functions is necessary for the setback to operate properly. The following table is only a guideline of recommended settings for these setpoints. It will be necessary for each customer to determine the best setpoints for their application based on experience.

Normal Drying Temp	Setback Return Temp Screen #27	Setback Temp (Process) Screen #26
160° F {71° C}	120° F {49° C}	150° F {66° C}
240° F {116° C}	135° F {57° C}	180° F {82° C}
300° F {149° C}	160° F {71° C}	200° F {93° C}
340° F {171° C}	180° F {82° C}	220° F {104° C}

## Setback Feature Guidelines (continued)

A recommended way to determine the “Setback Return Temperature” setpoint is to monitor the actual temperature of this function during pre-drying of your material at start-up, and while running at your normal maximum material throughput. The “Setback Return Temperature” setpoint should be set 10 to 20° above maximum temperature noted in these situations.

The “Setback Temperature (Process)” setpoint you select should be adequate to reduce the temperature significantly enough to prevent over-drying of your material. However, keep in mind that the cooler the temperature selected, the longer it will take for the material to heat back up to its proper drying temperature once the dryer comes out of Setback mode.

When drying at low temperatures (for example 160 - 180° F {71 - 82° C}), you are able to setback the temperature only a small amount. The “Setback Temperature (Process)” should not be set lower than 150° F {66° C}, even if the control will allow it. It is very likely the dryer will not be able to achieve low temperatures without adding additional cooling to the process air circuit. The maximum achievable setpoint is dependent on the temperature of the return air coming back to the dryer. As the return air temperature climbs, the temperature that the dryer is capable of controlling at climbs. For example, if the return air to the dryer is 110° F {43° C}, the dryer may not be able to control at a “Setback Temperature (Process)” setpoint below 150 - 155° F {66 - 68°C}.



**NOTE:** Selecting too low of a setpoint for Screen 26 may result in nuisance Process Temperature Loop Break alarms if the dryer is not able to achieve this setpoint.

# Maintenance

---

Preventative maintenance checklist . . . . .	5-2
Checking the dewpoint . . . . .	5-3
Cleaning the hopper . . . . .	5-5
Cleaning the process filter . . . . .	5-6
Cleaning the regeneration filter . . . . .	5-7
Cleaning the aftercooler coils . . . . .	5-8
Cleaning the precooler coils . . . . .	5-9
Inspecting hoses and gaskets . . . . .	5-9

# Preventative Maintenance Checklist

Routine maintenance will ensure optimum operation and performance of the W Series Dryer. We recommend the following maintenance schedule and tasks.

- **Whenever you change materials**

- Drain and clean the hopper.**

- **Weekly, or as often as needed**

- Clean or replace the process and regeneration filters.**  
You may need to clean filters more often than weekly. Frequency depends on how much material you process and how dusty or full of fines it is.
- Inspect hoses and hose connections.**  
Check for damage, kinks, or loose hose clamps. Replace any hoses that show signs of damage or wear. Reposition and tighten loose hose clamps.

- **Monthly**

- Clean the aftercooler and optional precool coils.**  
You may need to clean the coils more often than monthly. Frequency will depend on the type and volume of material you process.

- **Every six months**

- Inspect gaskets for damage or wear.**  
Damaged gaskets can allow moisture to seep into the closed-loop drying system. Replace any gasket that is torn or cracked.
- Verify dewpoint readout and performance** with a calibrated portable dewpoint instrument.
- Measure current draw on all 3 legs of heater wires.** This is to ensure that the heater is working properly.

# Checking the Dewpoint

It is a good idea to monitor the dewpoint performance of your dryer periodically with a calibrated portable dewpoint monitor, to ensure it is performing at maximum capacity. Even if your dryer has a dewpoint readout, comparing it to a portable instrument periodically will confirm that the dewpoint sensor and readout is performing properly.

## To Check Dewpoint:

- 1 Connect your portable dewpoint meter to the dewpoint check port of the dryer.**
- 2 Turn on the portable instrument,** and ensure there is positive airflow through the sensor.
- 3 Monitor the readout and allow ample time for it to stabilize before disconnecting the dewpoint monitor.** Some dewpoint monitors require a substantial amount of time for residual moisture to be purged from the sensor.
- 4 In the event the dewpoint is not satisfactory,** refer to the *Troubleshooting section* of the manual, under Process Dewpoint alarm for DC2.



## Alternate Procedure: (for dryers with no dewpoint check port)

- 1 Stop dryer and allow it to cool.**
- 2 Remove the plastic cover** from the dryer., and locate the process heater tube.
- 3 Connect a portable dewpoint instrument to the 1/8 inch NPT port at the process air outlet of the desiccant wheel assembly.** If there are existing connections for the dryer's dewpoint sensor, locate a 2nd 1/8 inch NPT port, or connect your dewpoint sensor in series with the dryer sensor. Do not install a tee to split the air between the dryer's sensor and your portable instrument. This may cause one of them to be starved for adequate sample air.



**NOTE:** Portable dewpoint monitors purchased from Conair are provided with a male connector that plugs into the dewpoint check port. If you purchased your portable instrument elsewhere, the male connector is available through the Conair parts department.



**NOTE:** The dewpoint check port was not included on the initial release of the Carousel Plus Dryers. It can be added easily. Contact the Conair parts department or follow the alternate procedure.

**Replacement dewpoint monitors, male connectors and dewpoint check ports are available from Conair.**

Contact Conair Parts  
(800) 458 1960  
From outside of the  
United States, call:  
(814) 437 6861

(continued)

## Checking the Dewpoint (continued)

- 4 Turn on the dryer.**
- 5 Turn on the portable instrument,** and ensure there is positive airflow through the sensor.
- 6 Monitor the readout and allow ample time for it to stabilize before disconnecting the portable instrument.** Some dewpoint monitors require a substantial amount of time for residual moisture to be purged from the sensor.
- 7 In the event the dewpoint is not satisfactory,** refer to the *Troubleshooting section* of the manual, under Process Dewpoint alarm for DC2.
- 8 Stop the dryer and allow it to cool down.** After the dryer has cooled, disconnect the portable instrument and replace any pipe plugs that may have been removed.
- 9 Replace the plastic cover** on the dryer.

# Cleaning the Hopper



**CAUTION: Hot surfaces.** Always protect yourself from hot surfaces inside and outside the dryer and drying hopper.

The hopper, spreader cone, and discharge assembly should be cleaned thoroughly between material changes to prevent resin contamination.

- 1 Close the hopper slide gate.**
- 2 Disconnect the hoses and remove the distribution box under the hopper** and drain the remaining material into a bucket.
- 3 Remove the spreader cone.** Open the hopper door. Reach into the hopper. Grasp the spreader cone tube, lift up slightly, twist and then push down to release it. Tilt the cone assembly and pull it out through the hopper door.
- 4 Clean the spreader cone and the inside of the hopper.** Make sure you also clean the return air screen at the return air outlet of the hopper.
- 5 Repeat the steps in reverse order** to reassemble the hopper before adding material.



# Cleaning the Process Filter

Clogged filters reduce air flow and dryer efficiency. Cleaning frequency depends on how much material you process and how dusty or full of fines it is.



## **CAUTION: Hot Surfaces.**

Always protect yourself from hot surfaces inside the dryer and hopper. Also exercise caution around exterior surfaces that may become hot during use. These include the hopper door frame, the exterior of an uninsulated hopper, the return air hose and the dryer's process filter housing and moisture exhaust outlet.



**1** To access the filter, push down and turn the top of the filter housing in a clockwise direction to remove.

**2** Remove the filter cartridge from the filter housing.

**3** Clean or replace the filter.



**CAUTION: Wear eye protection.** If you use compressed air to clean the equipment, **you must wear eye protection** and observe all OSHA and other safety regulations pertaining to the use of compressed air.

**4** Wipe the inside of the filter housing clean, then replace the filter cartridge into the housing.

**5** Line up the slots in the top of the filter housing, push down and turn counterclockwise until locked into place.

# Cleaning the Regeneration Filter

Clogged filters reduce air flow and dryer efficiency. Cleaning frequency depends on how much material you process and how dusty or full of fines it is.

- 1** To access the regeneration filter, **use a small flat screwdriver to gently pry down on the slot in the lower right hand corner of the filter grill while pulling out on the bottom.**



**CAUTION: Hot surfaces.**  
Always protect yourself from hot surfaces inside and outside the dryer and drying hopper.

- 2** Remove the filter from inside the grill and clean with soap and water.
- 3** Replace the filter in the grill and snap the grill into place.

# Cleaning the Aftercooler Coils

The aftercooler coils will need to be kept clean to keep the aftercooler working efficiently. Cleaning frequency depends on the type and amount of material you process.



**1 Stop the dryer and lockout the main power.**



**2 Turn off the water flow to the water supply line.** Disconnect supply and return lines.

 **NOTE:** If an optional flow control was added with the aftercooler, remove the compression fitting from the aftercooler. Loosen the fitting on the flow control, then swing the copper water supply tube out and away from the aftercooler.

**3 Remove the two (2) nuts securing the aftercooler** in the housing.

 **TIP:** If the aftercooler (without a flow control) was installed using the recommended 24 inches {61 cm} of flexible hoses, there is no need to disconnect the hoses from the aftercooler inlet and outlet.

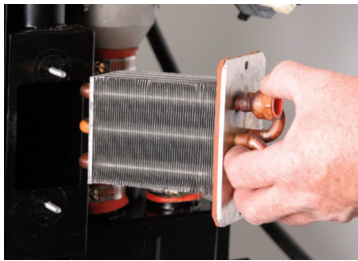

**4 Remove the aftercooler** from the aftercooler housing.

**5 Clean the assembly using a mild soap and water.** Let the assembly dry thoroughly before installation.

**6 Inspect the condition of the gasket.** If it is damaged, replace the gasket.

**7 Reassemble** by repeating the steps in reverse order.

**8 Connect the water supply line to the inlet.** If a manual shut off valve is used, it should be mounted on the inlet line as well.

**9 Connect the outlet of the aftercooler to the inlet of the flow control valve** using the pre-shaped copper tubing and compression fittings provided.

## Cleaning the Precooler Coils

If you have the optional precooler, you need to clean the cooling coils to keep them working efficiently. See Appendix B for details.

## Inspecting Hoses and Gaskets

Loose or damaged hoses and gaskets can allow moisture to seep into the closed-loop drying system.

- 1 Follow the hose routing of all the hoses within the dryer and inspect all hoses, clamps, fittings, and gaskets.**
- 2 Tighten any loose hose clamps or fittings.**
- 3 Replace worn or damaged hoses and gaskets.**



# Troubleshooting

---

Before beginning . . . . . 6-2

A few words of caution . . . . . 6-3

## DIAGNOSTICS

How to identify the cause of a problem . . . . 6-4

Shutdown alarms . . . . . 6-5

Passive alarms . . . . . 6-12

Dewpoint troubleshooting . . . . . 6-20

Poor material drying troubleshooting . . . . 6-21

## REPAIR

Replacing fuses . . . . . 6-26

Checking heater solid state relays . . . . . 6-27

Checking or replacing temperature

    sensors . . . . . 6-28

Replacing the heaters

    Regeneration heater tube . . . . . 6-29

    Process heater tube . . . . . 6-31

Replacing the desiccant wheel assembly . . . 6-33

Replacing the desiccant wheel motor . . . . 6-34



# Before Beginning

 **NOTE:** Use of test mode screens 28-43 may assist with the determining of possible cause of an alarm. Access code 756.

You can avoid most problems by following the recommended installation and maintenance procedures outlined in this User Guide. If you do have a problem, this section will help you determine what caused it and how to fix it.

**Before you remove the cover from the dryer be sure to:**

**Diagnose causes from the control panel.**

- 1** Press  once to silence the optional audible alarm and display the alarm message.
- 2** Address the alarm message and fix the problem. (Refer to the alarm descriptions later in this section.)
- 3** Press  again to clear the alarm. If the alarm reappears the problem was not fixed.

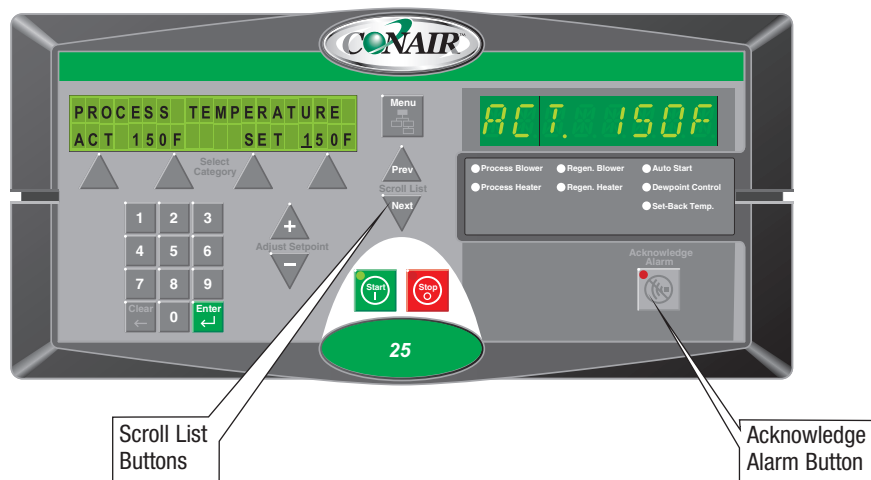

## Before Beginning (continued)

- ❑ **Find the wiring and equipment diagrams that were shipped with your dryer.** These diagrams are the best reference for correcting a problem. The diagrams also will note any custom features, such as special wiring or alarm capabilities, not covered in this User Guide.

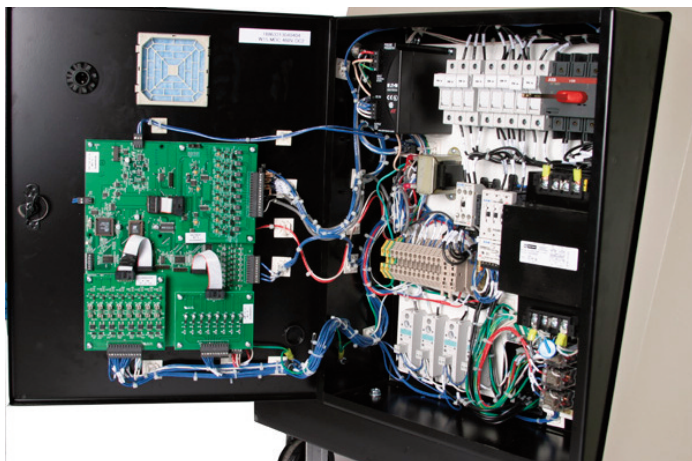

See warnings below. Open the electrical enclosure to check fuses and heater contactors.

## A Few Words of Caution

The Carousel Plus W Series Dryer is equipped with numerous safety devices. Do not remove or disable them. Improper corrective action can lead to hazardous conditions and should never be attempted to sustain production.

 **WARNING: Only qualified service personnel should examine and correct problems that require opening the dryer's electrical enclosure or using electrical wires to diagnose the cause.**

 **WARNING: High voltage. Always stop the Carousel Plus Dryer, disconnect and lock out the main power source before troubleshooting or performing repairs.**

 **CAUTION: Hot surfaces. Always protect yourself from hot surfaces inside and outside of the dryer and hopper.**

# How to Identify the Cause of a Problem

 **NOTE:** Pushing the Acknowledge Alarm button when there is no active alarm will take the user directly to the Alarm History list (Screen 95, page 4-33).

 **NOTE:** The dryer cannot be started if a passive alarm is present on power-up.

Dryer alarms are indicated by an illuminated Acknowledge Alarm light on the Carousel Plus W Series Dryer control panel. Shutdown alarms will sound the alarm horn and turn on the alarm beacon.

## A problem can trigger two types of alarms:

- **Shutdown:** The dryer has automatically shut down because it has detected a serious problem that could damage your material or dryer.
- **Passive:** The dryer continues to operate, but warns of a problem that could prevent correct drying of your material. If ignored, this problem could lead to a condition that will shut down the dryer.

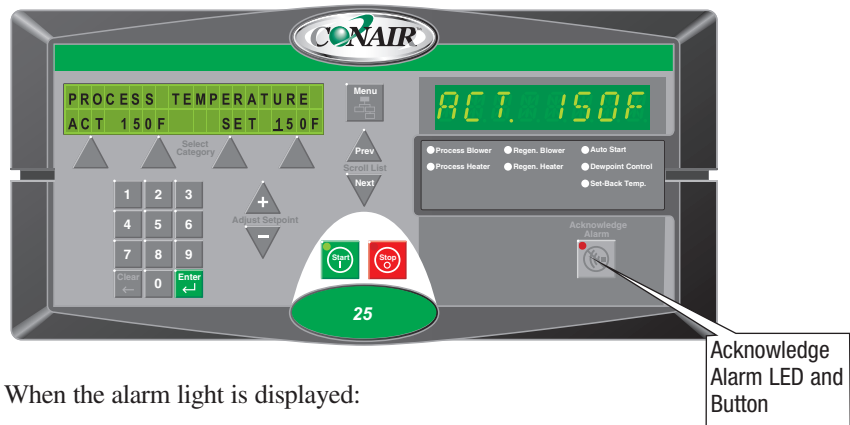

When the alarm light is displayed:

- 1 Press the Acknowledge Alarm button once to silence the optional audible alarm and display the alarm message.** Pressing the Acknowledge Alarm button once also changes the alarm LED from blinking to solid.
- 2 Find the error message in the diagnostics table of this *Troubleshooting* section.** Use the information in the table to resolve the cause of the alarm.
- 3 Note that pressing the Acknowledge Alarm button a second time will clear the alarm.** If at alarm reappears, the cause of the alarm has not been resolved.

 **NOTE:** When the dryer detects abnormally high temperature in the process heater, the dryer immediately shuts down and an error message appears in the display window.



### Central

When supplied for central drying applications, these shutdown alarms are not available.

## Shutdown Alarms

If the red Acknowledge Alarm LED is blinking, the alarm is a shutdown alarm. The dryer will shut down automatically to prevent damage to the equipment or personnel. Note that when the Acknowledge Alarm button is pressed once, the blinking red LED becomes solid.

Problem	Possible cause	Solution
<b>Process High Temperature</b> – If the process temperature exceeds the process high temperature setpoint, it shuts down the dryer. Defaults are set to 385°F {196°C} for 20 seconds.	The process high temperature setpoint is not at least 10°F {6°C} above the drying setpoint.	Reset the process high temperature setpoint at least 10°F {6°C} above the drying setpoint.
	One of the process solid state relays has failed.	Replace the solid state relay.
	The air lines are restricted or loose.	Straighten any crimps in the hoses. Tighten any loose hoses.
	The process setpoint is too low.	Set the process setpoint higher or install an optional precooler.
<b>Process Temperature Loop Break</b> – If the process temperature is outside of the operator entered deviation, alarm band (see Process High Temperature Deviation passive alarm) and the process temperature is not moving towards the setpoint at a rate greater than specified. It shuts down the dryer. Defaults are set at 3°F {3°C} over 20 seconds.	The process heater output on the control board has failed.	Replace the control board.
	Process RTD is loose or has fallen out.	Check the process RTD and tighten if needed.
	The process heater has failed.	Check the heater fuses, and resistance across each leg of the process heater.
	The air lines are restricted or loose.	Straighten any crimps in the hoses. Tighten any loose hoses.
	The process blower is not running or is running in the wrong direction.	Correct the cause of the non-running blower (blown fuse, etc.) or reverse the rotation of the blower. <i>See Installation section entitled, Checking for proper air flow.</i>
	The process heater output on the board has failed or the output fuse has failed.	Replace the board or the fuse for the output.
	Process setpoint is too low.	Adjust the setpoint or add a precooler.
Setback setpoint is too low.	Adjust the setpoint or add a precooler.	



### Central

When supplied for central drying applications, these shutdown alarms are not available.

## Shutdown Alarms

If the red Acknowledge Alarm LED is blinking, the alarm is a shutdown alarm. The dryer will shut down automatically to prevent damage to the equipment or personnel. Note that when the Acknowledge Alarm button is pressed once, the blinking red LED becomes solid.

Problem	Possible cause	Solution
<b>Process Heater High Temperature</b> – The snap switch in the process heater tube opens due to excessive temperature.	There is an airflow blockage or loose hoses.	Locate and remove any airflow restrictions.  Tighten any loose hoses.
	The process blower is not running or running in the wrong direction.	Correct the cause of the non-running blower (blown fuse, etc.) or reverse the rotation of the blower. <i>See Installation section entitled, Checking for proper air flow.</i>
	The isolation contactor failed in the closed position.	Replace the isolation contactor.
	The process heater output on the board has failed.	Replace the board.
	The heater solid state relays (SSRs) failed.	Replace the failed heater solid state relays (SSRs).
<b>Regeneration Heater High Temperature</b> – The snap switch in the regeneration heater tube activated due to excessive temperature.	The regeneration exhaust is blocked or the air hoses are loose.	Locate and remove any airflow restrictions.  Tighten any loose hoses.
	The regeneration blower is not running or running in the wrong direction.	Correct the cause of the non-running blower (blown fuse, etc.) or reverse the rotation of the blower. <i>See Installation section entitled, Checking for proper air flow.</i>
	The isolation contactor failed in the closed position.	Replace the isolation contactor.
	The heater solid state relays (SSRs) failed.	Replace the failed heater solid state relays (SSRs).
	The regeneration heater output on the board has failed.	Replace the board.

# Shutdown Alarms

If the red Acknowledge Alarm LED is blinking, the alarm is a shutdown alarm. The dryer will shut down automatically to prevent damage to the equipment or personnel. Note that when the Acknowledge Alarm button is pressed once, the blinking red LED becomes solid.

Problem	Possible cause	Solution
<p><b>Return Air High Temperature</b> – If the return air temperature at the inlet to the blower is greater than 180°F {82°C}, it shuts the dryer down.</p>	<p>The hopper does not contain enough material.</p> <p>You are drying at a high drying temperature above 240°F {116°C} or you are running at low throughputs.</p> <p>The aftercooler does not have enough water.</p> <p>The aftercooler coils are dirty.</p>	<p>Make sure your material supply system is working properly.</p> <p>Ensure water flow to the aftercooler.</p> <p>Turn on the water supply, or fix any leaks or blockages.</p> <p>Clean the aftercooler coils. <i>See Maintenance section entitled, Cleaning the aftercooler coils.</i></p>
<p><b>Process RTD Integrity</b> – If the process RTD is faulty, it shuts the dryer down.</p>	<p>The process RTD connection to the control box is loose.</p> <p>The connection in the electrical enclosure for the process RTD is loose.</p> <p>The connection of the RTD plug on the control board is loose.</p> <p>The process RTD has failed.</p> <p>The control board has failed.</p>	<p>Check the connection to the receptacle and tighten if needed.</p> <p>Check the RTD plug connection and tighten if needed.</p> <p>Check the plug connection and tighten if needed.</p> <p>Replace the process RTD.</p> <p>Replace the control board.</p>
<p><b>Regeneration RTD Integrity</b> – If the regeneration RTD is faulty, it shuts the dryer down.</p>	<p>There is a loose connection in the wiring leading to the RTD.</p> <p>The connection of the RTD plug on the control board is loose.</p> <p>The regeneration RTD has failed.</p> <p>The control board has failed.</p>	<p>Check the RTD plug connection and make the necessary repairs.</p> <p>Check the plug connection and tighten if needed.</p> <p>Replace the regeneration RTD.</p> <p>Replace the control board.</p>



Central

When supplied for central drying applications, these shutdown alarms are not available.

## Shutdown Alarms

If the red Acknowledge Alarm LED is blinking, the alarm is a shutdown alarm. The dryer will shut down automatically to prevent damage to the equipment or personnel. Note that when the Acknowledge Alarm button is pressed once, the blinking red LED becomes solid.

Problem	Possible cause	Solution
<b>Control Communications Watchdog</b> - The display board has lost communications with the control board.	Plugs on wire harness between the display and control boards are loose or not wired correctly.	Make sure plugs are tight on board connections and match the wiring diagram.
	Display or communication boards have failed.	Replace the defective boards.
<b>Phase Error (Phase Option)</b> - One of the three power wires is connected wrong or one or more phase of power missing.	One of the three power wires are out of phase.	Switch the position of two of the incoming lead power wires at the dryer.
	A fuse has blown.	Check and replace the fuse.
	Loose wire between the phase board and the control board.	Make sure the wires are connected and secure.
<b>EEProm Write Error</b>	Phase detection board has failed.	Replace the phase detection board.
	Internal control board problem.	Replace the control board.
<b>Process Protection High Temperature</b> – If the process protection temperature exceeds the process protection high temperature setpoint, it shuts down the dryer. Defaults are set to 600°F {316°C} for 10 seconds.	The process RTD temperature probe is not installed correctly.	Make sure the RTD temperature probe tip is in the center of the hopper inlet tube.
	The process blower is not running.	Correct the cause of the non-functioning blower.
	The air lines between the dryer and hopper are restricted or loose.	Straighten any crimps in the hoses. Tighten any loose hoses.
	The dryer is too far from the hopper.	Move the dryer closer to the hopper and shorten the hoses.
	The process hose is not insulated.	Insulated hose is required for high drying temperatures.



### Central

When supplied for central drying applications, these shutdown alarms are not available.

## Shutdown Alarms

If the red Acknowledge Alarm LED is blinking, the alarm is a shutdown alarm. The dryer will shut down automatically to prevent damage to the equipment or personnel. Note that when the Acknowledge Alarm button is pressed once, the blinking red LED becomes solid.

Problem	Possible cause	Solution
<p><b>Process Protection RTD Integrity</b> – If the process protection RTD is faulty, it shuts the dryer down.</p>	<p>There is a loose connection in the wiring leading to the RTD.</p> <p>The connection of the RTD plug on the control board is loose.</p> <p>The process protection RTD has failed.</p> <p>The control board has failed.</p>	<p>Check the RTD plug connections and make any necessary repairs.</p> <p>Check the plug connection and tighten if needed.</p> <p>Replace the process protection RTD.</p> <p>Replace the control board.</p>

# Shutdown Alarms

If the red Acknowledge Alarm LED is blinking, the alarm is a shutdown alarm. The dryer will shut down automatically to prevent damage to the equipment or personnel. Note that when the Acknowledge Alarm button is pressed once, the blinking red LED becomes solid.

## Problem

**Process Blower Overload** - If the process blower exceeds its full load amp rating or the overload has tripped due to a mechanical or electrical problem the dryer will shut down.

 **NOTE:** Once the overload has tripped, you must wait 2 to 15 minutes with the power on for the overload to reset automatically.

## Possible cause

The process blower current draw has exceeded the full load amps rating of the motor.

The process blower has mechanically failed or is unable to rotate freely.

The process blower has failed electrically.

Loss of phase of power to the motor starter.

The overload is set incorrectly.

The overload is defective.

## Solution

Press alarm acknowledge and allow the overload to reset then try to restart the dryer. If the alarm condition occurs again have a qualified electrician check the current draw to the motor.

Disconnect and lock out main power. Check the process blower for mechanical failure and free rotation. Replace if necessary. Allow the overload to reset then try to restart the dryer.

Disconnect and lock out main power. Check the process blower for electrical shorts or open circuits. Replace if necessary. Allow the overload to reset then try to restart the dryer.

Check for a blown fuse in the dryer or main power supply. Allow the overload to reset then try to restart the dryer.

Disconnect and lock out main power. Check the overload settings and confirm that the settings match the full load amps listed on the process blower motor. Allow the overload to reset then try to restart the dryer.

Replace the overload.

# Shutdown Alarms

If the red Acknowledge Alarm LED is blinking, the alarm is a shutdown alarm. The dryer will shut down automatically to prevent damage to the equipment or personnel. Note that when the Acknowledge Alarm button is pressed once, the blinking red LED becomes solid.

## Problem

**Process Protection Differential** - If the difference between the process temperature exiting the process heater and the temperature of the air entering the hopper is greater than 175°F {97°C} for longer than 180 seconds it shuts down the dryer.

## Possible cause

The air lines between the dryer and hopper are restricted or loose.

The dryer is located too far away from the hopper.

The process RTD is loose or has fallen out.

The process blower is not running.

The process hose is not insulated.

## Solution

Check for air flow blockages or loose hoses between the outlet of the dryer and the inlet of the hopper. Straighten any crimps in the hoses. Tighten any loose hoses.

The dryer and the hopper should not be located more than 10 feet {3m} apart.

Check the process RTD and tighten if needed.

Correct the cause of the non-functioning blower.

Insulated hose is required for high drying temperatures.



Central

When supplied for central drying applications, these shutdown alarms are not available.

## Passive Alarms

If the amber Acknowledge Alarm LED is blinking, the alarm is a passive alarm. The dryer continues to operate, but this problem could prevent correct drying of your material. Note that when the Acknowledge Alarm button is pressed once, the blinking amber LED becomes solid.

 **NOTE:** Passive alarms can be configured as shutdown alarms (see the previous Shutdown Alarms section). See page 4-25, screen 62 for instructions.

Problem	Possible cause	Solution
<b>Process Temperature Deviation</b> – The process temperature exceeds the deviation band as entered for the specified time. Default values are 10°F {6°C} for 5 seconds.	One of the solid state relays (SSRs) failed in the closed position.	Replace the failed solid state relays (SSRs).
	Defective process heater.	Check the heater fuses and resistance across each leg of the process heater.
	The output on the board has failed.	Replace the board.
	The process RTD is loose or has fallen out.	Check the process RTD and tighten if needed.
	The air hose connections are loose.	Tighten all air hose connections.
<b>Process Low Temperature</b> – The process temperature is less than the low temperature setpoint for the specified time. Default values are 70°F {21°C} for 20 seconds.	Precooler water is too cold, or the water flow rate is too high.	Check water temperature and flow settings. Adjust as necessary.
	The output on the board has failed.	Replace the board.
	Flow control solenoid is stuck open.	Replace the valve.
	The process RTD is loose or has fallen out.	Check the process RTD and tighten if needed.
<b>Regeneration Temperature Deviation</b> – The regeneration temperature exceeds the deviation band for the specified time. Default values are 10°F {6°C} for 5 seconds.	Process heater has failed.	Check the heater fuses and resistance across each leg of the process heater.
	One of the SSRs has failed.	Replace the failed SSRs.
	The regeneration RTD is loose or has fallen out.	Check the regeneration RTD and tighten if needed.
	The air hose connections are loose.	Tighten all air hose connections.
	The output on the board has failed.	Replace the board.
Defective regeneration heater.	Check the heater fuses and resistance across each leg of the regeneration heater.	

# Passive Alarms

If the amber Acknowledge Alarm LED is blinking, the alarm is a passive alarm. The dryer continues to operate, but this problem could prevent correct drying of your material. Note that when the Acknowledge Alarm button is pressed once, the blinking amber LED becomes solid.



**NOTE:** Passive alarms can be configured as shutdown alarms (see the previous Shutdown Alarms section). See page 4-25 screen 62 for instructions.

Problem	Possible cause	Solution
<p><b>Return Air Mid-High Temperature</b> – If the return air temperature is between 150 and 180°F {66 and 82°C}.</p>	<p>The hopper does not contain enough material.</p> <p>You are drying at a high drying temperature (above 240°F {116°C}) or running at low throughputs.</p> <p>The aftercooler does not have enough water.</p> <p>The aftercooler coils are dirty.</p>	<p>Make sure your material supply system is working properly.</p> <p>Ensure water flow to the aftercooler.</p> <p>Turn on the water supply, or fix any leaks or blockages.</p> <p>Clean the aftercooler coils. <i>See Maintenance section entitled, Cleaning the aftercooler coils.</i></p>
<p><b>Regeneration Low Temperature</b> – The regeneration temperature is less than the low temperature setpoint for the specified time. Defaults are 200°F {93°C} for 20 seconds.</p>	<p>The regeneration heater has failed.</p> <p>The output on the control board has failed or the fuse has blown.</p> <p>The regeneration RTD is loose or has fallen out.</p>	<p>Check the heater fuses, and resistance across each leg of the process heater.</p> <p>Replace the control board or the fuse.</p> <p>Check the regeneration RTD and tighten if needed.</p>
<p><b>Regeneration High Temperature</b> – If the regeneration temperature exceeds the high temperature limit for the specified time. Default values are 400°F {204°C} for 20 seconds.</p>	<p>One of the solid state relays (SSRs) failed in the closed position.</p> <p>The output on the board has failed.</p>	<p>Replace the failed solid state relays (SSRs).</p> <p>Replace the board.</p>

# Passive Alarms

If the amber Acknowledge Alarm LED is blinking, the alarm is a passive alarm. The dryer continues to operate, but this problem could prevent correct drying of your material. Note that when the Acknowledge Alarm button is pressed once, the blinking amber LED becomes solid.



**NOTE:** Passive alarms can be configured as shutdown alarms (see the previous Shutdown Alarms section). See page 4-25, screen 62 for instructions.

Problem	Possible cause	Solution
<p><b>Regeneration Temperature Loop Break</b> – The regeneration temperature is outside of the operator entered deviation alarm band (see Regeneration Temperature Deviation passive alarm) and the regeneration temperature is not moving towards the setpoint at a rate greater than specified. Default values are 2°F {1°C} over 40 seconds.</p> <p><b>Process Dewpoint</b> – The dewpoint has not fallen below the setpoint. If the dewpoint goes below the setpoint for 180 seconds the alarm should go away.</p> <p> <b>NOTE:</b> The alarm is not active for the first 5 minutes.</p>	<p>The regeneration heater has failed.</p> <p>The regeneration RTD is loose or has fallen out.</p> <p>The regeneration blower is not running.</p> <p>The output on the control board has failed or the fuse is blown.</p> <p>Defective dewpoint sensor.</p> <p>The hose or wiring connections to the sensor block are loose or have fallen off.</p> <p>Poor regeneration air flow.</p> <p>The desiccant wheel may be contaminated.</p> <p>Desiccant wheel not turning.</p> <p>Leaks in the process air stream.</p>	<p>Check the heater fuses, and resistance across each leg of the process heater.</p> <p>Check the regeneration RTD and tighten if needed.</p> <p>Correct the cause of the non-functioning blower. <i>See Installation section entitled, Checking for proper air flow.</i></p> <p>Replace the control board or fuse.</p> <p>Replace the sensor.</p> <p>Check wiring and hose connections to the sensor, resecure if needed.</p> <p>Remove the air flow restrictions, dirty filters, etc.</p> <p>Check the desiccant for contamination, replace if needed. Install plasticizer / volatile trap for severe situations.</p> <p>Replace the desiccant wheel. <i>See Troubleshooting section entitled, Replacing the desiccant wheel.</i></p> <p><i>See Troubleshooting section entitled, Passive alarms, Wheel rotation failure.</i></p> <p>Check for worn or lose hoses.</p>

## Passive Alarms

If the amber Acknowledge Alarm LED is blinking, the alarm is a passive alarm. The dryer continues to operate, but this problem could prevent correct drying of your material. Note that when the Acknowledge Alarm button is pressed once, the blinking amber LED becomes solid.



**NOTE:** Passive alarms can be configured as shutdown alarms (see the previous Shutdown Alarms section). See page 4-25, screen 62 for instructions.

Problem	Possible cause	Solution
<b>Process Filter Clogged (Option)</b> – The process filter differential pressure switch is tripped.	The process air filter is clogged.	Remove and clean or replace the process air filter.
<b>CFM Low (Option)</b> - The CFM calculated from the process blower differential pressure is less than the setpoint (1 CFM for 30 seconds - see screen 66) entered on the operator display.	The air hoses are loose, blocked, or kinked.	Check the process air hose for secure connections, straighten any blocked or kinked hose.
	The return air filter needs to be cleaned.	Clean and/or change the return air filter.
<b>Return Air Temperature RTD Integrity</b> – The dryer continues to run with a passive alarm.	There is a loose connection in the wiring leading to the RTD.	Check the RTD plug connections and make any necessary repairs.
	The connection of the RTD plug on the control board is loose.	Check the plug connection and tighten if needed.
	The return air RTD has failed.	Replace the return air RTD.
	The control board has failed.	Replace the control board.

# Passive Alarms

If the amber Acknowledge Alarm LED is blinking, the alarm is a passive alarm. The dryer continues to operate, but this problem could prevent correct drying of your material. Note that when the Acknowledge Alarm button is pressed once, the blinking amber LED becomes solid.



**NOTE:** Passive alarms can be configured as shutdown alarms (see the previous Shutdown Alarms section). See page 4-25, screen 62 for instructions.

Problem	Possible cause	Solution
<p><b>Setback RTD Integrity</b> - The control can not sense the setback RTD.</p>	<p>The connection in the electrical enclosure for the hopper RTD is loose.</p> <p>The connection of the RTD plug on the control board is loose.</p> <p>The setback RTD has failed.</p> <p>The control board has failed.</p>	<p>Check the RTD plug connection and tighten if needed.</p> <p>Check the plug connection and tighten if needed.</p> <p>Replace the setback RTD.</p> <p>Replace the control board.</p>
<p><b>Wheel Rotation Failure</b> - The regeneration temperature differential has been reached.</p>	<p>The wheel motor is not turning.</p> <p>The belt tensioner is loose or the belt is slipping.</p> <p>The regeneration heater is not working.</p>	<p>Check the motor, plugs, and fuses.</p> <p>Change the tensioner spring or replace the belt.</p> <p>Check the heater fuses and heater.</p>
<p><b>Regeneration Outlet RTD Integrity</b> - The control can not sense the regeneration outlet RTD.</p>	<p>There is a loose connection in the wiring leading to the RTD.</p> <p>The connection of the RTD plug on the control board is loose.</p> <p>The regeneration outlet RTD has failed.</p> <p>The control board has failed.</p>	<p>Check the RTD plug connections and make any necessary repairs.</p> <p>Check the plug connection and tighten if needed.</p> <p>Replace the regeneration outlet RTD.</p> <p>Replace the control board.</p>

# Passive Alarms

If the amber Acknowledge Alarm LED is blinking, the alarm is a passive alarm. The dryer continues to operate, but this problem could prevent correct drying of your material. Note that when the Acknowledge Alarm button is pressed once, the blinking amber LED becomes solid.



**NOTE:** Passive alarms can be configured as shutdown alarms (see the previous Shutdown Alarms section). See page 4-25, screen 62 for instructions.

Problem	Possible cause	Solution
<p><b>Dewpoint Deviation High</b> - Displayed when the actual dewpoint goes above the setpoint by a specified amount of time and degrees. Defaults are set for 5°F {3°C} for 30 seconds.</p>	<p>The hose or wiring connections to the sensor block are loose or have fallen off.</p> <p>Poor regeneration air flow.</p> <p>The desiccant wheel is not turning.</p> <p>The desiccant wheel may be contaminated.</p>	<p>Check wiring and hose connections to the sensor, resecure if needed.</p> <p>Remove the air flow restrictions, dirty filters, etc.</p> <p><i>See Troubleshooting section entitled, Passive alarms, Wheel rotation failure.</i></p> <p>Check the desiccant for contamination, replace if needed. Install plasticizer/volatile trap for severe situations.</p> <p>Replace the desiccant wheel. <i>See Troubleshooting section entitled, Replacing the desiccant wheel.</i></p>
<p><b>Dewpoint Deviation Low</b> - Displayed when the actual dewpoint goes below the setpoint by a specified amount of time and degrees. Defaults are set for 5°F {3°C} for 30 seconds.</p>	<p>Leaks in the process air stream.</p> <p>The dewpoint can not control to the desired setpoint.</p> <p>The dewpoint sensor has failed.</p>	<p>Check for worn or loose hoses.</p> <p>Material and/or ambient conditions may be too dry to increase the actual dewpoint. Please wait several hours to determine if the setpoint can be reached. Increase the dewpoint low deviation value.</p> <p>Replace the dewpoint sensor.</p>

# Additional Alarms

Along with the alarm indicators, you may encounter additional messages that indicate a problem within the control.

Problem	Possible cause	Solution
<p><b>Control Not Ready, Please Check Alarm</b> - Displayed when the “Start” button is pushed during any active alarm. (Passive or Shutdown)</p>	<p>The dryer will continue to run if there is a passive alarm, however it will not start if there is a active alarm.</p>	<p>Push the acknowledgement alarm button to identify the alarm, and address it as necessary.</p>
<p><b>Lost Comm w/ Ctrl Bd</b> - Indicates there is a problem in the communication between the control board and the display board.</p>	<p>Loose or improperly connected wire.</p> <p>Improper dip switch setup on control board.</p> <p>Defective display or control board.</p>	<p>Check wiring between control board and display board.</p> <p>Check dip switch setup on control board.</p> <p>Replace boards as a set.</p>
<p><b>Error ! Incorrect Firm Version</b> - Indicates a mismatch of software between the display board and the control board.</p>	<p>The software revision of the display board and control board are not compatible.</p>	<p>In most cases, both display and control boards will need to be replaced as a set.</p>



# Dewpoint Troubleshooting

Under normal operating conditions, the dryer will produce dewpoints in the range of -40 to -20° F {-40 to -29° C}. However, you may experience situations that produce undesirable results.

## Problem

**Dryer not producing desired dewpoint.**

## Possible cause

Return air temperature exceeds 125°F {52°C}.

Regeneration temperature is below normal setting.

Low regeneration air flow.

Leaks in process lines.

Contaminated desiccant due to off-gassing, too long of a residence time or drying temperature is too high for the grade of material being processed.

Analog option board/sensor malfunction

## Solution

Reduce the temperature of the cooling water to the aftercooler or increase the flow.

Check amperage of regeneration heaters. Replace heaters if necessary.



**WARNING:** Any electrical checks should be performed by a qualified electrician.

Check regeneration filter and clean and/or replace as necessary.

Check all hoses, gaskets, doors, loaders or other potential areas where leakage may occur. Replace any defective hoses or gaskets.

Verify proper drying temperatures and residence times. If off-gassing is a condition of the material being processed, contact Conair Parts for the addition of a volitale trap.

Verify dryer dewpoint readings with a calibrated portable dewpoint meter.

Replace analog option board or sensor.

# Poor Material Drying Troubleshooting

Occasionally, processing problems that are suspected of being caused by poor drying are eventually determined to be the result of other issues in the process setup. The intent of the information provided here is to assist you in determining if your drying system is performing properly. However, the only way to know definitely if your material is properly dried is to perform moisture analysis of small samples as it leaves the bottom of the hopper, or just as it enters the process. Conair does not sell moisture-analyzing equipment, but there are many brands of this equipment available on the market.

You should also be aware that some processing problems may actually be the result of over drying material. Most materials will degrade to some extent if they are exposed to their specified drying temperature for a time significantly longer than the residence time specified by the supplier. If you want to maintain its dryness, it is recommended that you reduce the process air temperature. If your Conair dryer is equipped with the Setback feature, you should familiarize yourself with it, and make use of it. If not, you may want to contact Conair to determine if it can be added to your dryer.

A majority of customer questions to Conair are related to dewpoint. It is important to realize that dewpoint is one of **four** requirements that need to be satisfied.

**There are four requirements, listed in order of importance, necessary to properly dry hygroscopic plastic resins:**

- 1** **Drying temperature** of the air entering the hopper must be at the proper drying temperature for your material, as specified by your material supplier.
- 2** **Residence time** is the time, determined by your material supplier, that the material in use must be heated to achieve proper drying temperature.
- 3** **Airflow** during the process drying circuit must be adequate to carry and distribute the heat throughout the entire bed of material inside the hopper.
- 4** **Dewpoint** of the process air must be low so it can efficiently collect the moisture as it is released from the heated material and carry it to the dryer to be removed in the desiccant.

# Poor Material Drying Troubleshooting (continued)

Once it is determined which of the four requirements that is not being satisfied, refer to the following list and possible causes and solutions.

**Temperature** - The temperature of the air entering the hopper must be at the proper drying temperature for your material, as specified by your supplier.

<b>Problem</b>	<b>Possible cause</b>	<b>Solution</b>
<b>The temperature of the air entering the hopper is not at proper drying temperature.</b>	Incorrect setpoint	Refer to the drying specifications for your material and adjust the setpoint to the recommended setpoint.  If your dryer has the Setback option, make sure it is not active unless you have specifically activated it. If necessary, refer to the Operation section of this manual for assistance in using the Setback function.
	Not able to achieve setpoint.	Replace any defective process heater, contactors, fuses, etc.  Ensure the selected drying temperature is within the design specifications of your dryer.
	Inaccurate process temperature readout.	Ensure the Process RTD is properly positioned in the air stream.  Determine if there is a problem in the temperature control circuit and repair or replace any defective components such as RTD, temperature control, circuit boards, etc.

# Poor Material Drying Troubleshooting (continued)

**Residence Time** - The time your material supplier has determined that the material in use must be heated to its drying temperature to achieve proper drying.

<b>Problem</b>	<b>Possible cause</b>	<b>Solution</b>
<b>Material residence time is too long or short.</b>	Material level in hopper is too low.	Make sure there is an adequate supply of material to feed the loader on top of the drying hopper.  Correct any problems with the conveying system that may be preventing your loader from filling the hopper.  If your hopper has a level sensor for maintaining a material level less than completely full, be sure this sensor is adjusted properly.
	Material throughput is too high.	Take any necessary steps, such as slowing down the process, to ensure the material usage is within design specifications of the dryer and hopper.

# Poor Material Drying Troubleshooting (continued)

**Airflow** - The airflow in the process drying circuit must be adequate to carry and distribute the heat throughout the entire bed of material inside the hopper. If the airflow is too low, the material in the center of the hopper may get heated fully to the drying temperature, but the material against the sidewalls will not. In most cases, the material 2/3 to 3/4 of the way toward the top of the hopper should be heated to the proper drying temperature. Running your hand along the sidewall of the hopper and roughly determining if the material is evenly heated is one way to determine if you have proper airflow.

## Problem

**Too much or too little airflow.**



**NOTE:** If there is too much airflow, the material may fluidize inside the hopper, resulting in inconsistent material flow through the hopper, which can negatively impact residence time.

## Possible cause

Dirty process air filter.

Collapsed hoses or holes/leaks in the hoses and hose connection.

Airflow restrictions.

Process blower running backwards or performing poorly.

Material level in the hopper too low.

## Solution

Clean or replace the process filter.

Replace any worn or damaged hoses. Tighten all hose clamps to eliminate leaks.

Remove any obstructions in the process air circuit.

Verify the process blower is running in the correct direction. If backwards, reverse direction by switching any 2 legs of high voltage to the motor.



**WARNING:** Any electrical checks should be performed by a qualified electrician.

Repair or replace motor.

Other than running out of material to complete a job, the material level inside the hopper must be a minimum of 50% full. If the hopper is not at least half full, the material in the cone section will not get adequate airflow to dry properly.

# Poor Material Drying Troubleshooting (continued)

Replacement dewpoint monitors are available from Conair.

Contact Conair Parts  
(800) 458 1960  
From outside of the  
United States, call:  
(814) 437 6861

**Dewpoint** - The process air must be at a low dewpoint so it can efficiently collect the moisture as it is released from the heated material and carry it to the dryer to be removed in the desiccant. In most cases, the dryer will dry your material satisfactorily if the dewpoint of the air is -20 to -40° F {-29 to -40° C}. If your dryer does not have a dewpoint readout, you can check the dewpoint with a portable dewpoint instrument. Conair sells a variety of portable dewpoint meters. Contact Conair Parts.

Problem	Possible cause	Solution
Dryer dewpoint is not reaching proper setpoint.	Low regeneration temperature.	Replace or check defective heaters, fuses etc.
	Poor regeneration airflow.	Clean or replace the regeneration filter.  Ensure the regeneration blower is operating properly and rotating in the correct direction. <i>See Installation section entitled, Checking for proper air flow.</i>
	High dewpoint, ambient air leaking into the closed loop drying circuit.	Remove obstructions in the air stream, such as crimped hoses, etc.  Replace damaged hoses and seal any leaks in the process air circuit.  If using a vacuum loader on the hopper, ensure that the loader shroud is installed in the hopper and that the hopper is completely filled with material.  If partially filling your hopper, ensure that the hopper loader is sealed against ambient air.  Install a gasket between the loader and the top of the hopper.
	Return air temperature to the dryer is too high.	Clean aftercooler coils. <i>See Maintenance section entitled, Cleaning the aftercooler coils.</i>
	Poor desiccant performance.	<i>See Troubleshooting section, entitled Replacing the desiccant wheel assembly.</i>

# Replacing Fuses



- 1 Disconnect and lockout the main power supply.** 
- 2 Open the electrical enclosure door.**
- 3 Check the fuse.** If necessary, pull the fuse out and replace it with a fuse of the same type and rating.

## Fuse Blocks

To locate the appropriate fuse and replacement part, refer to the wiring diagrams that came with your dryer.



**IMPORTANT:** Always refer to the wiring diagrams that came with your dryer to locate specific electrical components. Illustrations in the User Guide are intended to be representative only.



# Checking Heater Solid State Relays

- 1 Disconnect and lockout the main power supply. 
- 2 Open the electrical enclosure.
- 3 Locate the process or regeneration relays. Refer to the wiring diagrams that came with your dryer.
- 4 Check continuity using an ohmmeter.



**IMPORTANT:** Always refer to the wiring diagrams that came with your dryer to locate specific electrical components. Illustrations in the User Guide are intended to be representative only.

## Regeneration heater solid state relays

If ohms equal zero or infinity, replace the relays.

## Process heater solid state relays

If ohms equal zero or infinity, replace the relays.

# Checking or Replacing Temperature Sensors

The Carousel Plus W Series Dryer uses RTD sensors to monitor the temperatures of the drying air, the return air, the regeneration outlet, the regeneration inlet process protection and setback at the outlet of the hopper.



**IMPORTANT:** Always refer to the wiring diagrams that came with your dryer to locate specific electrical components. Illustrations in the User Guide are intended to be representative only.



Location of the Process RTD at the Hopper inlet.

To check or replace RTD sensors:



**1** Disconnect and lockout the main power supply. 

**2** Remove dryer cover, as necessary.

**3** Locate the RTD sensors.

**4** Check the sensor positions and conditions. Temperature readings will be incorrect, if the sensors are touching the wall of an air hose or pipe or if the sensor or wiring is damaged. The tip of the sensor should be centered within the air hose or pipe. Sensor wires should be attached to the appropriate connection points on the dryer's electrical enclosure or microprocessor board.

**5** To check with ohm meter, measure the resistance across the RTDs. The resistance should be approximately 110 ohm at room temperature.

**6** Replace the sensor, if necessary.

# Replacing the Heaters

## Regeneration Heater Tube

**1** Stop the dryer, disconnect the power, and follow proper lockout procedures.



**2** Remove the plastic cover.



Regeneration Heater



**3** Disconnect the wiring harnesses of the defective regeneration heater. Then disconnect the hoses from the top and bottom of the heater tube.

**4** Remove the clamp securing the heater tube in place then remove the heater tube from the dryer.

**5** Cut the insulation in a straight line from end to end then remove it from the old heater tube.

**6** Compare the markings on the outside of the regeneration heater tube to ensure the new one has the same voltage and kW ratings as the original heater tube.

**7** Put the insulation on the new heater tube. Use duct tape to hold the seam together.

**8** Secure the new heater tube using the hose clamp removed in Step 4.

**9** Connect the hoses to the top and the bottom of the regeneration heater tube.

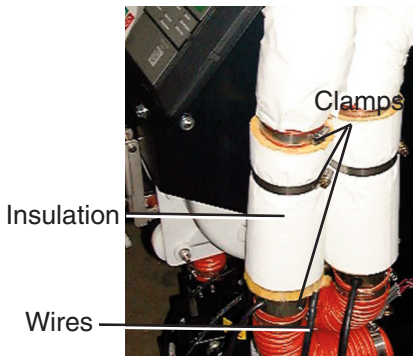

# Replacing the Heaters

## Regeneration Heater Tube (continued)

- 10** Connect the wiring harnesses from the regeneration heater tube to the existing harnesses from the control box.
- 11** Replace the plastic cover.
- 12** Make sure the regeneration heater fuses are not blown before applying power to the new heater.

# Replacing the Heaters

## Process Heater Tube

**1** Stop the dryer, disconnect the power, and follow proper lockout procedures. 

**2** Remove the plastic cover. 

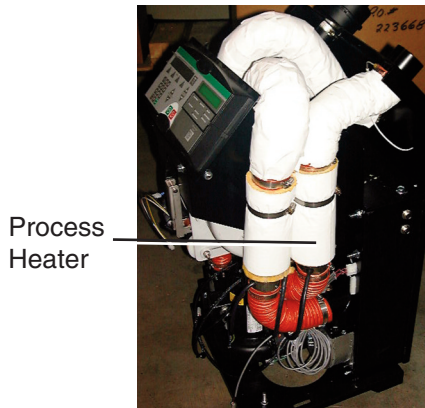

**3** Disconnect the wiring harnesses of the defective process heater. Then disconnect the hoses from the top and bottom of the heater tube.

**4** Remove the clamp securing the heater tube in place then remove the heater tube from the dryer.

**5** Cut the insulation in a straight line from end to end then remove it from the old heater tube.

**6** Compare the markings on the outside of the process heater tube to ensure the new one has the same voltage and kW ratings as the original heater tube.

**7** Put the insulation on the new heater tube. Use duct tape to hold the seam together.

**8** Secure the new heater tube using the hose clamp removed in Step 4.

**9** Connect the hoses to the top and the bottom of the process heater tube.



Central

When configured as a central dryer, there is no process heater in the system. Therefore, replacing the process heater is not applicable.

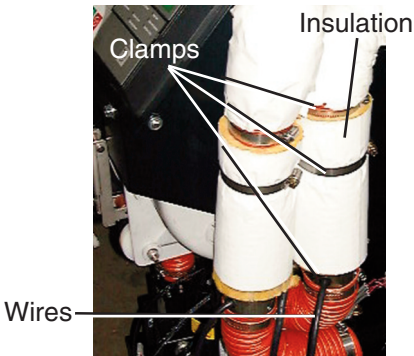

continued



Central

When configured as a central dryer, there is no process heater in the system. Therefore, replacing the process heater is not applicable.



## Replacing the Heaters

### Process Heater Tube (continued)

- 10** Connect the wiring harnesses from the process heater tube to the existing harnesses from the control box.
- 11** Replace the plastic cover.
- 12** Make sure the process heater fuses are not blown before applying power to the new heater.

# Replacing the Desiccant Wheel Assembly

If the desiccant becomes clogged or contaminated, you should replace the desiccant wheel assembly to ensure optimum performance.

- 1 Stop the dryer, disconnect the power, and follow proper lockout procedures.** 
- 2 Remove the plastic cover from the dryer.** 
- 3 Unbolt the control panel/user interface from the wheel assembly, disconnect wires, and set the interface aside.**
- 4 Disconnect all the hoses and RTD's from the wheel assembly.** Be sure to note the position of all hoses and RTDs for re-assembly.
- 5 Disconnect the wires to the wheel motor.**
- 6 Loosen the hose clamps** on the wheel assembly, then remove hoses.
- 7 Unbolt the wheel assembly** and remove it from the dryer.
- 8 Bolt the new wheel assembly into place.**
- 9 Return the heater tubes to their original location** and secure the hoses with the original hose clamps.
- 10 Connect the wheel motor to the wiring harness.**
- 11 Connect all hoses and RTDs to the wheel assembly.**
- 12 Connect the wires to the control panel/user interface and bolt it to the wheel assembly.**
- 13 Reconnect power and start the dryer.** Verify that the wheel rotates smoothly and in the correct direction.
- 14 Replace the plastic cover.**



**CAUTION:** Always disconnect and lock out the main power sources before making electrical connections. Electrical connections should be made only by qualified personnel.



## Replacing the Desiccant Wheel Motor

**1 Stop the dryer, disconnect and lockout the main power.** 

**2 Remove the plastic cover from the dryer.** 

**3 Disconnect wires to the desiccant wheel motor.**



**CAUTION:** Always disconnect and lock out the main power sources before making electrical connections. Electrical connections should be made only by qualified personnel.

**4 Remove the two (2) screws then remove the motor and motor bracket from the wheel manifold.**

**5 Loosen the set screw then remove the coupling from the motor shaft.**

**6 Remove the four (4) screws then remove the motor from the motor bracket.**

**7 Align the new motor with the holes in the original bracket.** Secure the new motor to the bracket using the original four (4) screws.

**8 Position the coupling on the motor shaft and tighten the set screw** against the flat side of the motor shaft.

**9 Position the motor and bracket on the desiccant wheel manifold.** Secure the assembly using the original two (2) screws.



**NOTE:** It may be necessary to apply power to the motor to position the coupling. Do not turn the motor shaft by hand. This will damage the gears.

**10 Connect the wires to the motor.**

**11 Replace the plastic cover.**

## We're Here to Help

Conair has made the largest investment in customer support in the plastics industry. Our service experts are available to help with any problem you might have installing and operating your equipment. Your Conair sales representative also can help analyze the nature of your problem, assuring that it did not result from misapplication or improper use.

Additional manuals and prints for your Conair equipment may be ordered through the Customer Service or Parts Department for a nominal fee. Most manuals can be downloaded free of charge from the product section of the Conair website.  
[www.conairgroup.com](http://www.conairgroup.com)

## How to Contact Customer Service

To contact Customer Service personnel, call:



 **NOTE:** Normal operating hours are 8:00 am - 5:00 pm (EST). After hours emergency service is available at the same phone number.

You can commission Conair service personnel to provide on-site service by contacting the Customer Service Department.

## Before You Call...

**If you do have a problem, please complete the following checklist before calling Conair:**

- Make sure you have all model, control type and serial numbers from the serial tag, and parts list numbers for your particular equipment. Service personnel will need this information to assist you..
- Make sure power is supplied to the equipment.
- Make sure that all connectors and wires within and between control systems and related components have been installed correctly.
- Check the troubleshooting guide of this manual for a solution.
- Thoroughly examine the instruction manual(s) for associated equipment, especially controls. Each manual may have its own troubleshooting guide to help you.
- Check that the equipment has been operated as described in this manual.
- Check accompanying schematic drawings for information on special considerations.

## Equipment Guarantee

Conair guarantees the machinery and equipment on this order, for a period as defined in the quotation from date of shipment, against defects in material and workmanship under the normal use and service for which it was recommended (except for parts that are typically replaced after normal usage, such as filters, liner plates, etc.). Conair's guarantee is limited to replacing, at our option, the part or parts determined by us to be defective after examination. The customer assumes the cost of transportation of the part or parts to and from the factory.

## Performance Warranty

Conair warrants that this equipment will perform at or above the ratings stated in specific quotations covering the equipment or as detailed in engineering specifications, provided the equipment is applied, installed, operated and maintained in the recommended manner as outlined in our quotation or specifications.

Should performance not meet warranted levels, Conair at its discretion will exercise one of the following options:

- Inspect the equipment and perform alterations or adjustments to satisfy performance claims. (Charges for such inspections and corrections will be waived unless failure to meet warranty is due to misapplication, improper installation, poor maintenance practices or improper operation.)
- Replace the original equipment with other Conair equipment that will meet original performance claims at no extra cost to the customer.
- Refund the invoiced cost to the customer. Credit is subject to prior notice by the customer at which time a Return Goods Authorization Number (RGA) will be issued by Conair's Service Department. Returned equipment must be well crated and in proper operating condition, including all parts. Returns must be prepaid.



Purchaser must notify Conair in writing of any claim and provide a customer receipt and other evidence that a claim is being made.

## Warranty Limitations

**Except for the Equipment Guarantee and Performance Warranty stated above, Conair disclaims all other warranties with respect to the equipment, express or implied, arising by operation of law, course of dealing, usage of trade or otherwise, including but not limited to the implied warranties of merchantability and fitness for a particular purpose.**

# Cleaning the Precooler Coils

The precooler coils will need to be kept clean to keep the precooler working efficiently. Cleaning frequency depends on the type and amount of material you process.

- 1 Stop the dryer and lockout the main power.** 
  - 2 Turn off the water flow to the water supply line.** Disconnect supply and return lines.  
  
 **NOTE:** If an optional flow control was added with the precooler, remove the compression fitting from the precooler inlet. Loosen the fitting on the flow control, then swing the copper water supply tube out and away from the precooler inlet.
  - 3 Remove the two (2) nuts securing the precooler** in the housing.
- ❖ **TIP:** If the precooler (without a flow control) was installed using the recommended 24 inches {61 cm} of flexible hoses, there is no need to disconnect the hoses from the precooler inlet and outlet.
- 4 Remove the precooler assembly** from the precooler housing.
  - 5 Clean the assembly using a mild soap and water.** Let the assembly dry thoroughly before installation.
  - 6 Inspect the condition of the gasket.** If it is damaged, replace the gasket.
  - 7 Reassemble** by repeating the steps in reverse order.
  - 8 Connect the water supply line to the inlet.** If a manual shut off valve is used, it should be mounted on the inlet line as well.
  - 9 Connect the outlet of the precooler to the inlet of the flow control valve** using the pre-shaped copper tubing and compression fittings provided.

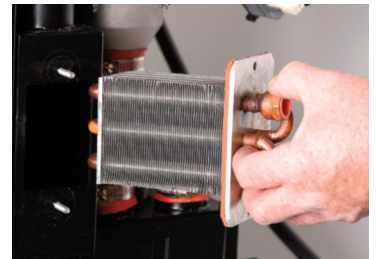





# **Addendum**

# **Communication Protocols for**

# **Common Controls**

**Modbus Communications, Ethernet Communications, DeviceNet Gateway  
Communications and SPI Communications**

**DISCLAIMER:** The Conair Group, Inc., shall not be liable for errors contained in this User Guide or for incidental, consequential damages in connection with the furnishing, performance or use of this information. Conair makes no warranty of any kind with regard to this information, including, but not limited to the implied warranties of merchantability and fitness for a particular purpose.

# Table of Contents

## A-1 Modbus Communications

Description of Modbus communications .....	A-2
Installing the Modbus communication hardware .....	A-2
Using the Modbus parameter list .....	A-2

## B-1 Ethernet Communications

Description of Ethernet communications .....	B-2
Installing the Ethernet communication hardware .....	B-2
Using the Ethernet parameter list .....	B-3

## C-1 DeviceNet Communications

Description of DeviceNet communications .....	C-2
Installing the DeviceNet communication hardware .....	C-2
Using the DeviceNet communication dip switch settings .....	C-2
Using the LED status indicators .....	C-5
Configuring the DeviceNet software	
Installing the EDS files .....	C-5
EDS file parameter list configuration options .....	C-6
Adding the gateway to the scan list .....	C-8
Explicitly writing to the gateway .....	C-11
Gateway parameter list .....	C-12

## **D-1** SPI Communications

Description of SPI communications . . . . .	D-2
Installing the SPI communication hardware . . . . .	D-2
Configuring the SPI communication software . . . . .	D-2
Supporting dryer SPI commands. . . . .	D-4

## **A** Appendix

Modbus RS-232/485 serial communications parameters . . . . .	A-1
DC-2 control parameters (used on dryers with DC-2 controls) . . . . .	A-1
DC plus control parameters (used on ResinWorks or Hopper Temperature Controllers (HTC)) . . . . .	A-2
Related drawings . . . . .	A-3
Modbus TCP/IP communications parameters . . . . .	A-4

# Modbus Communications

---

Description of Modbus Communications . . . .	A-2
Installing the Modbus	
Communication Hardware . . . . .	A-2
Using the Modbus Parameter List. . . . .	A-2

# Description of Modbus Communications

The common controls series of products from Conair use standard Modbus communications protocol to allow the user to access the control boards for supervisory type functions. For example, you may want to display the drying temperature for all hoppers in a facility in one central location. By connecting all the dryers to a central computer, the temperatures and setpoints can be displayed in one location using a standard SCADA software program such as Wonderware or RSView.

Depending on the particular common controls board, the Modbus serial communication interface maybe be either RS-232 (DC-2 control board) or RS-485 (DC control board). Converters may be ordered with the product to convert from one to the other. The RS-485 standard allows multiple controllers to be daisy-chained together over longer distances while the RS-232 allows direct connection to most personal computers without an interface adapter.

## Installing the Modbus Communication Hardware

The hardware required for Modbus communications is included with the product when it is shipped. Connectors and cabling must be supplied by the user or ordered from Conair. A converter is available if your controls do not use the standard communications you desire. See Appendix A page A-3 for the proper cabling and connection information for both types of interface.

## Using the Modbus Parameter List

The Modbus interface uses standard Modbus protocol to communicate with a common controls system. The data that may be retrieved is arranged in a parameter list. By using the Modbus register read and write commands, the desired data may be read from or written to the controller. The list of data that may be set or retrieved with the common controls system is arranged in Modbus registers 500 to 539. See Appendix A page A-1 for the data contained in this area for your particular type of equipment. DC-2 control parameters are used on a dryer with a DC-2 control panel and DC plus control parameters are used with Hopper Temperature Controllers (HTC) or ResinWorks.

# Using the Modbus Parameter List

**(continued)**



**CAUTION:** The list of data that may be read and written to by the user is arranged in a specific location (parameters 500 to 540). Writing to a location with improper data, or writing to an incorrect location outside of the specified range may cause your common controls system to become inoperative or to operate in a manner that may damage your process. Be certain that you understand each parameter and its effect before changing anything. Conair recommends that you initially attempt to read from the registers and do not attempt any writes. Once the information you are trying to read has been confirmed as accurate, you can program your new/additional data.



# **Ethernet Communications**

---

Description of Ethernet Communications . . . .	B-2
Installing the Ethernet	
Communication Hardware . . . . .	B-2
Using the Ethernet Parameter List . . . . .	B-3

# Description of Ethernet Communications

Modbus TCP/IP is a protocol that takes the basic Modbus command set that was originally developed for serial communications, and applies it to the Ethernet standard via TCP/IP protocol. Beginning in 2006 this protocol can be ordered as an option on the Common Control's dryers. When the option is ordered, an additional Ethernet module is soldered on to the main control board of the dryer. This Ethernet module can not be added to an existing dryer control board. Adding the option to an existing dryer will require replacing the main control board with a new board containing the Ethernet module. Depending on the revision level and display type, the display board may need to be replaced. For easier set-up, a short length of Ethernet cable is run from the connector on the control board to an Ethernet receptacle mounted on the control enclosure. This allows you to plug into the Ethernet port without having to open the control enclosure.

## Installing the Ethernet Communication Hardware

The control boards are shipped with a default Internet Protocol (IP) address of 010.001.010.254. In order for your dryer to communicate with your network, this default IP address should be changed to match the network structure used in your plant. Changing the IP address is accomplished through the DC-2 operator interface display board.

**To change the IP address:**

- 1 Enter the supervisory level password (0210).** See your dryer manual for directions if necessary.
- 2 Once the password has been entered, go to “Setup”>”Other”>Comm.**
- 3 When the “Comm” menu is displayed, scroll down through the list until “IP Addr Part 1” is displayed.** This is the first octet (first three numbers) of the IP address. For example if the IP address is 192.168.0.100, “192” would be shown as the value in this field. If desired, change the first octet at this location.

(continued)

## Installing the Ethernet Communication Hardware (continued)

- 4** Once you have entered the correct value, scroll down one more time until “IP Addr Part 2” is displayed. This is the second octet (first three numbers) of the IP address and may be changed if necessary.
- 5** Scrolling further down you will see additional fields for the remaining IP address octets, the subnet mask and the gateway. Once all fields have been changed, cycling the power to the dryer will complete the process and reinitialize the Ethernet interface.

## Using the Ethernet Parameter List

Please refer to page Appendix A page A-4 for a list of the parameters that are available with the Modbus TCP/IP interface.



**CAUTION:** Writing to a location with improper data, or writing to an incorrect location outside of the specified range may cause your common controls system to become inoperative or to operate in a manner that may damage your process. Be certain that you understand each parameter and its effect before changing anything. Conair recommends that you initially attempt to read from the registers and do not complete any writes. Once the information you are trying to read has been confirmed as accurate, you can now program in your new or additional data.



**NOTE:** The list of parameters that may be read and written to via Modbus TCP/IP is extensive. Some of these parameters are naturally a part of the operation of the machine and others may be obscure configuration settings. The parameter list in Appendix A page A-4 includes a column with a recommendation as to whether the parameter should be accessed by a user program. Addresses that are not consecutive indicate that there are other parameters present which are not recommended for usage by the user.



# DeviceNet Communications

---

Description of DeviceNet Communications . . .	C-2
Installing the DeviceNet	
Communication Hardware . . . . .	C-2
Using the DeviceNet Communication	
Dip switch Settings . . . . .	C-2
Using the LED Status Indicators. . . . .	C-5
Configuring the DeviceNet Software	
Installing the EDS Files . . . . .	C-5
EDS File Parameter List	
Configuration Options . . . . .	C-6
Adding the Gateway to the Scan List. . . .	C-8
Explicitly Writing to the Gateway . . . . .	C-11
Gateway Parameter List . . . . .	C-12



# Description of DeviceNet Communications

The Conair Common Control board set allows you to add DeviceNet communications for information interchange with PLC systems or higher level supervisory computer systems. The DeviceNet communication is accomplished with a gateway device that converts the Modbus communications already existing on the DC-2 display board or the DC control cabinet , but may also be purchased with a DIN rail mounted enclosure. It is available with RS-232 (for the DC-2 control) or RS-485 (DC control) communications capability. These instructions assume the user is familiar with basic DeviceNet configuration and use. If not, please refer to manuals from your DeviceNet provider before attempting to use this function.

## Installing the DeviceNet Communication Hardware

The DeviceNet Gateway is designed to mount to three standoffs which are attached to the door of the control cabinet below the main control board. Note that the gateway circuit board has two holes to mount the gateway and the board just rests on the third standoff to help stabilize the board. Cable 188629-04 connects between the gateway's three pin connector and the control board, connector J4. The DeviceNet drop cable is then ran to the five pin connector on the gateway.

## Using the DeviceNet Communication Dip Switch Settings

The gateway has two groups of DIP switches for setup. The first set of switches (labeled S1 on the circuit board or next to the "address" label on the enclosure) is used to configure the address of the gateway on the DeviceNet network and the baud rate used by the gateway for DeviceNet communications. The second set of switches (labeled S2 on the circuit board or next the "number of controllers label) is used to set the number of controllers attached to the gateway (only for RS-485 communications), to set the baud rate used to communicate between the gateway and the dryer, and to set the number of words of data transferred from the gateway to the DeviceNet scanner (10 or 20 words of data). See next page for dip switch configuration.

# Using the DeviceNet Communication Dip Switch Settings

(continued)

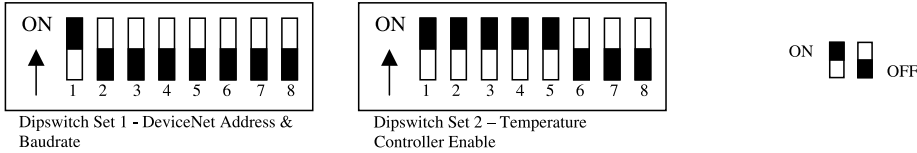

Figure I – Dipswitch Layout

Address (Decimal)	SW1 $2^0$	SW2 $2^1$	SW3 $2^2$	SW4 $2^3$	SW5 $2^4$	SW6 $2^5$
Default	ON	OFF	OFF	OFF	OFF	OFF
01	ON	OFF	OFF	OFF	OFF	OFF
15	ON	ON	ON	ON	OFF	OFF
40	OFF	OFF	OFF	ON	OFF	ON

Table 1 - Dipswitch Set 1 - DeviceNet Address

Baud Rate / Mode	SW7 $2^6$	SW8 $2^7$
125K	OFF	OFF
250K	ON	OFF
500K	OFF	ON
Software	ON	ON

Table 2 - Dipswitch Set 1 - DeviceNet Baud Rate

Dip switch 1 provides the DeviceNet MacId address and baud rate using the standard switch configurations found in most DeviceNet products. Switches 7 and 8 of switch set 1 allow the user to use DeviceNet software configuration tools to set the MacId address and baud rate. Factory default switch settings are 125k , Address 63.

(continued)

# Using the DeviceNet Communication Dip Switch Settings (continued)

Number Controllers	SW5	SW6	SW7	SW8
1	ON	OFF	OFF	OFF
2	OFF	ON	OFF	OFF
3	ON	ON	OFF	OFF
4	OFF	OFF	ON	OFF
5	ON	OFF	ON	OFF
6	OFF	ON	ON	OFF
7	ON	ON	ON	OFF
8	OFF	OFF	OFF	ON

Table 3 - Dipswitch Set 2 - Enable Athena Controllers

Dip switch set 2 identifies the Modbus addresses of controllers connected to the DeviceNet interface. From one to eight controllers can be enable for communication through a single Athena DeviceNet interface module.

ModBus Baud Rate	SW4
19200	ON
9600	OFF

Table 4 – Dipswitch Set 2 - Modbus Baud Rate

Dip switch set 2 position 4 identifies the baud rate used to read parameters on Modbus.

Modbus Parameters	SW1	SW2
User Configurable	OFF	OFF
Parameters 500 – 519	OFF	ON
Parameters 500 - 509	ON	OFF
User Configurable	ON	ON

Table 5 – Dipswitch Set 2 - Modbus Parameter List

Dip switch set 2 positions 1-2 identify the parameter list for the Conair controllers.

## Using the LED Status Indicators

There are two LEDs on the gateway which display the status of the communications. The first LED, which is located between the dip switches (labeled “Controllers” on the gateways with the enclosure), display the status of the Modbus communications between the gateway and the control circuit board. The second LED (labeled “DeviceNet” on the gateways with the enclosure) display the status of the DeviceNet communications.

### 1. Controller Status LED (between dip switches)

Color	State	Indication
None	Off	No power
Red	Solid	No controllers online
Red	Flashing	“Illegal Date” error
Green	Solid	Normal operation - All controllers online
Green	Flashing	One or more controllers offline or not present

### 2. DeviceNet Status LED

Color	State	Indication
None	Off	No power
Red	Solid	Unrecoverable DeviceNet fault
Red	Flashing	Output error or configuration error
Green	Solid	Normal operation
Green	Flashing	Device is in idle mode or not allocated to a master

## Configuring the DeviceNet Software

### Installing the EDS Files

There are multiple EDS (electronic date sheet) files associated with the gateway depending on how many controllers are attached to a gateway. The files are named based on the number of controllers (i.e. an EDS file for a gateway with three controllers attached is named 3Conair.EDS). Choose the appropriate file for your application and install it using your DeviceNet network’s EDS installer options. Once the EDS files are installed they will be shown under the “Conair Common Control” heading in the EDS file manager. If you install more than one of the EDS files the files will all be named “Conair Common Control” with the hexadecimal designator to differentiate the different files. By opening the devices parameter list you can tell how many controllers are associated with the EDS file.

(continued)

## Configuring the DeviceNet Software Installing the EDS Files (continued)

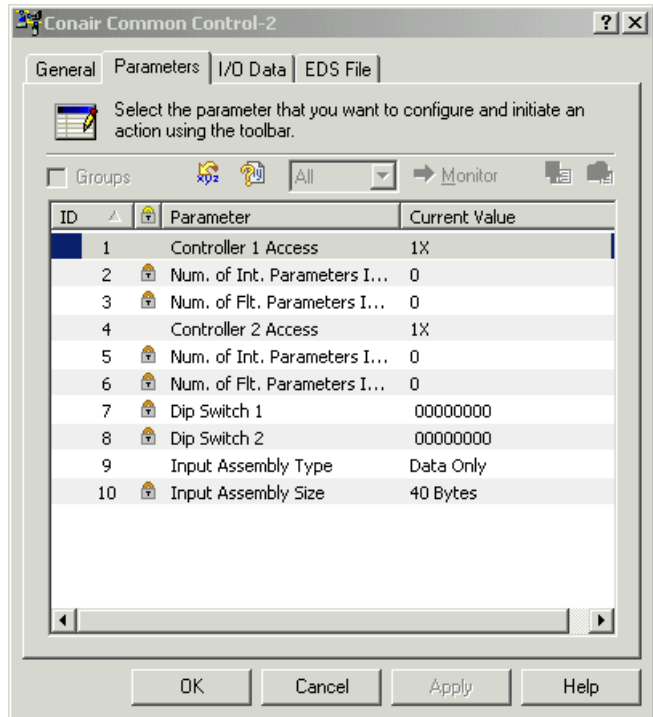

## Configuring the DeviceNet Software EDS File Parameter List Configuration Options

Once the EDS file has been installed the gateway may be added to a network configuration. There are a number of parameters that may be configured for each gateway to optimize it for your application. The number of parameters will vary depending on how many controllers are attached to a gateway.

# Configuring the DeviceNet Software

## EDS File Parameter List Configuration

### Options (continued)

There are seven types of parameters:

#### **Parameter 1    Controller Access    1X, 10X, 100X**

This parameter controls, the format of the data that is retrieved from the controller. If 1X is chosen the data will be retrieved as a whole number with no implied decimal place. For example, if a process temperature was retrieved and the real value of the temperature was 225.3927, the temperature would be read as 225 using the 1X register format. If 10X was chosen the raw data would be retrieved as 2253, requiring the user to add the implied decimal point to show the temperature as 225.3. Similarly, if the data was retrieved in the 100X format the raw data would be 22539 requiring the user to add the decimal place to display it as 225.39.

#### **Parameter 2    Number of Int. Parameters    0 to 40**

This field will display how many integer parameters are retrieved from the controller. This will be either 10 or 20 depending on the position of dip switch 2, switches 1 and 2.

#### **Parameter 3    Number of Flt Parameters    0 to 10**

This field will display how many floating point parameters are retrieved from the controller. The default is zero and is not normally changed by the user. If your application requires the use of floating point numbers, please consult with a Conair representative.

#### **Parameter 4    Dip switch 1    Combination of 1's and 0's**

This field shows the actual positions of dip switch 1 on the gateway.

#### **Parameter 5    Dip switch 2    Combination of 1's and 0's**

This field shows the actual positions of dip switch 2 on the gateway.



# Configuring the DeviceNet Software

## EDS File Parameter List Configuration

### Options (continued)

#### Parameter 6 Input Assembly Type Status only, Status w/data, Data only

This field will choose whether the data retrieved consists of only the process data from the controller (data only), the status bytes from the gateway (status only), or the data and the status bytes (status w/data).



**NOTE:** When this field is modified the change must be applied. The size of the data block being retrieved (see parameter 7) will change based on the configuration of this parameter.

#### Parameter 7 Input Assembly Size 0 to 160

This field will display the actual size of the input data that is being retrieved from the gateway to the master on the DeviceNet network. See the section on adding the gateway to the scan list for further information on the parameter.

# Configuring the DeviceNet Software

## Adding the Gateway to the Scan List

Adding the gateway to a scan list requires that the data area is sized correctly and mapped to the correct locations.

To add the gateway to the scan list:

- 1** Set all dip switches as described in the “*DeviceNet communications section, entitled Using the DeviceNet communication dip switch settings*”.
- 2** Go online with the device on the network and set the parameters described in the “*DeviceNet communications section, entitled Configuring the DeviceNet software, EDS File Parameter List Configuration Options*”.
- 3** Once the parameters are set, download the parameters to the gateway using the “Apply” button.

# Configuring the DeviceNet Software

## Adding the Gateway to the Scan List

(continued)

- 4 Close the parameter list and reopen**, once you have applied your parameters. Check Parameter 7 to see how many bytes of data are in the input assembly size.
- 5 Go online with the scanner and move the gateway from the “Available Devices” area to the “Scanlist” area using the arrow key.** After the gateway has been moved, the “Edit I/O Parameters” button should be accessible.

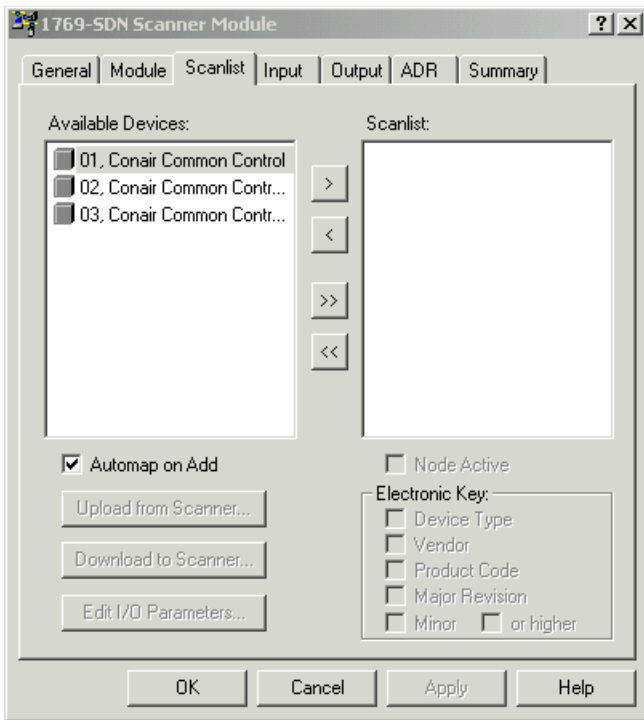

# Configuring the DeviceNet Software

## Adding the Gateway to the Scan List

(continued)

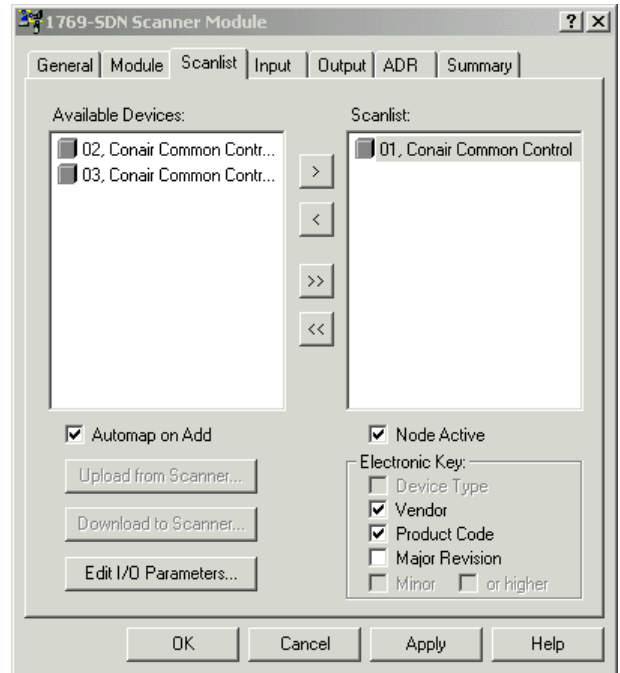

Press the “Edit I/O Parameter” button to to the configure the I/O parameters.

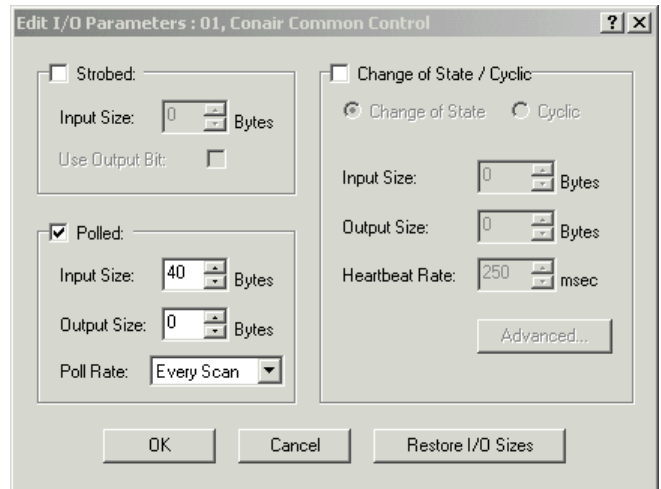

## Configuring the DeviceNet Software

### Adding the Gateway to the Scan List (continued)

- 6** Select the “OK” button once you have modified your input field size to match the number of bytes shown in Parameter 7. Since the actual data size being used differs from the maximum possible data size, you will get an error message noting this. Click the “OK” button to keep the data size you have entered.
- 7** Once the I/O parameters have been modified, the gateway may be mapped to your desired I/O area using the Input tab. Depending on whether your controller is 16 bit (Allen Bradley Micrologix) or 32 bit (Allen Bradley Controllogix) the data may transfer either as individual words (16 bit) or two parameter words may be combined into a DINT (32 bit). All parameters should now be accessible from the programmable logic controller. (PLC)

## Configuring the DeviceNet Software

### Explicitly Writing to the Gateway

As discussed above, the information from the Common Controls Systems can be set up to be read directly as inputs in a PLC system. In order to write data to the gateway it must be written in a DeviceNet Explicit message. The method was chosen to ensure that data is written once, only when the PLC decides it should be written. This reduces bandwidth on the network and ensures that the data is sent only when it is required. Note that parameters 530 to 539 are set up as the registers to write to the common controls devices. Please see your DeviceNet system provider’s information on using explicit messaging for more details.

## **Configuring the DeviceNet Software Gateway Parameter List**

Similarly to the Modbus communications, the Common Controls parameters that are available are stored in registers 500 to 539. The dip switches determine how much of the list is transferred to the PLC. If the dip switch is set for ten words, Modbus parameters 500 to 509 will be transferred to the input image of the scanner. If the dip switches are set for twenty words, Modbus parameters 500 to 519 will be transferred to the scanner. See Appendix A page A-1 for the actual parameters that are available from the type of common control device that your system is using.

# SPI Communications

---

Description of SPI Communications . . . . .	D-2
Installing the SPI	
Communication Hardware . . . . .	D-2
Configuring the SPI	
Communication Software . . . . .	D-2
Supported Dryer SPI Commands . . . . .	D-4

# Description of SPI Communications

The Society of Plastics Industry (SPI) has defined a standard protocol to be used for interconnecting plastics equipment. This protocol uses the RS-485 standard as the physical connection and defines stand addresses and commands to communicate with the various kinds of equipment in common use at a typical plastics facility. For example, a dryer is specified as Device ID 22 hex, a chiller is Device ID 21 hex. The data retrieved for each type of equipment is defined in the standard. For a dryer or other piece of equipment to be in compliance with the SPI standard you must be able to retrieve certain parameters such as the setpoint process temperature, high and low temperature deviation alarms, temperature to the process, temperature to the process, etc. Some parameters are also designated as optional parameters that may or may not be available depending on the equipment provider's discretion.

## Installing the SPI Communication Hardware

The SPI option is available with the DC-2 display boards. The display boards have a RS-232 port built into the board. The RS-232 to RS-485 converters are provided and mount on the inside of the door of the electrical cabinet. The RS-485 SPI signal is then brought to the outside of the cabinet by a 9 pin D-sub connector. Refer to Conair drawing 130024 and 188629 in Appendix A page A-3 for details of the installation. The RS-485 SPI signal is available on pins 4 and 5 of the DB-9 connector. Pins 8 and 9 also have the RS-485 connection (parallel with pins 4 and 5) to assist in daisy-chaining equipment together.

## Configuring the SPI Communication Software

The SPI protocol option must be turned on and configured in the operator display before it may be used.

### To setup the SPI communications:

- 1 Enter the supervisory level password (0210).** See your dryer manual for directions if necessary.

# Configuring the SPI Communication Software (continued)

- 2** Once the password has been entered, go to “Setup”>”Other”>Comm.
- 3** When the “Comm” menu is displayed, scroll down through the menu and set the “Protocol” to”SPI”. Set the slave ID to a unique address on the RS-485 network master. Once you have completed entering in your information, return to the opening menu and cycle the power on your equipment to establish the new settings.

In order to connect Conair equipment to a host computer system, Conair can provide an SPI-DDE server which will allow DDE compliant software packages such as Wonderware or Excel to connect to the SPI network with minimal programming required.

For more information on the SPI protocol, you can obtain the SPI Communication protocol manual by contacting:

The Society of Plastics Industry, Inc.  
1801 K Street, NW, Suite 600K  
Washington, D.C. 20006  
(202) 974-5200 Fax (202) 296-7005  
[www.plasticsindustry.com](http://www.plasticsindustry.com)



# Supported Dryer SPI Commands

SPI protocol defines two different modes, “Select” and “Poll”. “Select” commands are used to set or change the information in the dryer. For example, to change a temperature setpoint from 200°F to 250°F {93°C to 121°C} a “Select” command is used. “Poll” commands are used to read the information without changing or modifying it. For example, when you simply want to display the actual process temperature. In either case two hex command bytes are sent to the equipment to specify what communication action to take.

The following list shows the “Select” and “Poll” bytes along with a description of the information that may be retrieved from Conair dryers.

1. **Echo** - Allows the master to test a piece of equipment by writing 4 bytes of information to the equipment and then reading it back.

Select: 20h, 21h      Poll: 20h, 20h

2. **Version** - Read the SPI version from the equipment.

Select: NA      Poll: 20h, 22h

3. **Setpoint Process Temperature** - Sets and retrieves the process temperature setpoint.

Select: 20h, 31h      Poll: 20h, 30h

4. **Alarm, High Temperature Deviation** - Sets and retrieves the high temperature deviation alarm setpoint. Not that in Conair dryers there is actually only deviation setpoint that is used for both high and low temperature deviation. The last value written to either the high or the low will be the value that is used.

Select: 20h, 33h      Poll: 20h, 34h

5. **Alarm, Low Temperature Deviation** - Sets and retrieves the low temperature deviation alarm setpoint. Not that in Conair dryers there is actually only deviation setpoint that is used for both high and low temperature deviation. The last value written to either the high or the low will be the value that is used.

Select: 20h, 35h      Poll: 20h, 34h      (continued)

# Supported Dryer SPI Commands

**(continued)**

6. **Status, Process** - Indicates that the status of the process with each “bit” showing a particular condition.

**The “bits” are defined as follows:**

**Bit 0** - Processing (dryer running)

**Bit1** - Alarm, System (any alarm that indicates a problem that may affect the drying operation)

**Bit3** - Alarm, Machine (any alarm that indicates a problem with the dryer itself)

**Bit4** - Alarm, High Temperature Deviation

**Bit5** - Alarm, Low Temperature Deviation

**Bit6** - Reserved

**Bit7** - Reserved

**Bit8** - Alarm, Filter clogged

**Bit9** - Alarm, Low flow

**Bit10** - Alarm, High Dewpoint

**Bit11** - Reserved

**Bit12** - Reserved

**Bit13** - Reserved

**Bit14** - Temperature out of band deviation

**Bit15** - Not used

Select: NA

Poll: 20h, 40h

(continued)

# Supported Dryer SPI Commands

**(continued)**

7. **Status, Machine 1** - Indicates that the status of the dryer itself with each “bit” showing a particular condition.

**The “bits” are defined as follows:**

**Bit0** - Processing (dryer running)

**Bit1** - Alarm, System (any alarm that indicates a problem that may affect the drying operation)

**Bit2** - Alarm, Process (any alarm that indicates a problem with the process itself)

**Bit3** - Alarm, Machine (any alarm that indicates a problem with the dryer itself)

**Bit4** - Alarm, High Temperature (any temperature input)

**Bit5** - Alarm, Low Temperature (any temperature input)

**Bit6** - Reserved

**Bit7** - Reserved

**Bit8** - Reserved

**Bit9** - Alarm, Low flow

**Bit10** - Alarm, High voltage (not supported)

**Bit11** - Alarm, Low voltage (not supported)

**Bit12** - Alarm, High current (not supported)

**Bit13** - Alarm, Low current (not supported)

**Bit14** - Alarm, Phase

**Bit15**- Not used

Select: NA

Poll: 20h, 42h

(continued)

# Supported Dryer SPI Commands

**(continued)**

8. **Status, Machine 2** - This word shows the status of the Dryer itself with each bit showing a particular condition.

The “bits” are defined as follows:

**Bit0** - Processing (dryer running)

**Bit1** - Alarm, System (any alarm that indicates a problem that may affect the drying operation)

**Bit2** - Alarm, Process (any alarm that indicates a problem with the process itself)

**Bit3** - Alarm, Machine (any alarm that indicates a problem with the dryer itself)

**Bit4** - Fault Sensor

**Bit5** - Fault, Calibration

**Bit6** - Reserved

**Bit7** - Reserved

**Bit8** - Reserved

**Bit9** - Reserved

**Bit10** - Reserved

**Bit11** - Reserved

**Bit12** - Reserved

**Bit13** - Reserved

**Bit14** - Reserved

**Bit15**- Reserved

Select: NA

Poll: 20h, 44h

(continued)

# Supported Dryer SPI Commands

(continued)

9. **Mode, Machine** - This is used to start/stop the dryer, acknowledge alarms and observe the run status.

**Bit0** -Start/Stop (1 = running or start, 0 = stop or stopped)

**Bit1** - Acknowledge Alarms

Select: 20h, 49h      Poll: 20h, 48h

10. **Temperature, To Process** - This is the actual the actual process (drying) temperature controlled by the dryer.

Select: NA      Poll: 20h, 70h

11. **Temperature, From Process** - This is the actual temperature as read by the RTD at the exit of the drying hopper. This is the temperature that is used for setback control in the dryer. Note that this is an optional feature and the value may be invalid if the feature is not installed on the dryer.

Select: NA      Poll: 20h, 72h

12. **Flow, To Process** - This is the flow of dry air to the process. Note that this is an optional feature and the value may be invalid if the feature is not installed on the dryer.

Select: NA      Poll: 20h, 78h

13. **Dewpoint** - This is the actual dewpoint of the process air. Note that this is an optional feature and the value may be invalid if the feature is not installed on the dryer.

Select: NA      Poll: 20h, 7Ch

14. **Setpoint, High Dewpoint Alarm** - This is the setpoint for the dewpoint alarm triggered by 13.

Select: 20h, 81h      Poll: 20h, 80h

# Modbus RS-232/485 Serial Communication Parameters

## DC-2 Control Parameters - *Used on dryers with DC-2 Controls*

### Read Area

Modbus Register Number	Description	Comments
500	Product Type	
501	Process Temperature Setpoint	
502	Process Actual Temperature	
503	Process Temperature Setpoint (Setback)	
504	Return Air Temperature Out of Hopper	
505	Return Air Setpoint (Setback)	
506	Regeneration Actual Temperature	
507	Dewpoint Actual	
508	Operational Mode	
509	Running Status	
510	Return Air Actual	
511	Shutdown Alarms	
512	Passive Alarms	
513	Load Rate Setpoint (Setback)	
514	Average Load Rate Actual (Setback)	
515	Process Heater Output Actual %	
516	Regeneration Heater Output Actual %	
517	Process Protect Actual Temperature	
518	Product Type	
519	Product Type	



**NOTE:** DC Plus control parameters appear on the next page. DC Plus controls are used on ResinWorks and Hopper Temperature Controllers (HTCs).

### Write Area

Modbus Register Number	Description	Comments
530	Process Temperature Setpoint	
531	Process Temperature Setpoint (Setback)	
532	Return Air Setpoint (Setback)	
533	Load Rate Setpoint (Setback)	
534	PM 1 Dewpoint Setpoint	(continued)

# Modbus RS-232/485 Serial Communication Parameters (continued)

Modbus Register Number	Description	Comments
535	Start Command	1 = start
536	Stop Command	1 = stop
537	Alarm Acknowledge	
538	Process Temperature Setpoint	
539	Process Temperature Setpoint	

## DC Plus Control Parameters - Used on ResinWorks and Hopper Temperature Controllers (HTC)



**NOTE:** DC-2 control parameters appear on the previous page. DC-2 control parameters are used on dryers with DC-2 controls.

Modbus Register Number	Description	Comments
500	Product Type	
501	Process Temperature Setpoint	
502	Process Actual Temperature	
503	Process Temperature Setpoint (Setback)	
504	Return Air Temperature Out of Hopper	
505	Return Air Setpoint (Setback)	
506	Load Rate Setpoint (Setback)	
507	Average Load Rate Actual (Setback)	
508	Operational Mode	
509	Running Status	
510	Process Heater Output Actual %	
511	Alarms	
512	RTD Integrity Alarms	
513	Regeneration Actual Temperature	
514	Regeneration Heater Output Actual %	
515	Process Protect Actual Temperature	
516	Product Type	
517	Product Type	
518	Product Type	
519	Product Type	

# Modbus RS-232/485 Serial Communication Parameters (continued)

## DC Plus Control Parameters - *Used on ResinWorks and Hopper Temperature Controllers (HTC)*

Modbus Register Number	Description	Comments
530	Process Temperature Setpoint	
531	Process Temperature Setpoint (Setback)	
532	Return Air Setpoint (Setback)	
533	Load Rate Setpoint (Setback)	
534	PM 1 Dewpoint Setpoint	
535	Start Command	1 = start
536	Stop Command	1 = stop
537	Alarm Acknowledge	
538	Process Temperature Setpoint	
539	Process Temperature Setpoint	

## Related Drawings

130023 - Common Controls DeviceNet Gateway Assemblies, D dryers  
130023-02 - CDDS DeviceNet Gateway Assembly  
130023-03 - Common Controls DeviceNet Gateway Assemblies, W dryers  
13024 - Common Controls SPI Communications Assembly  
188629 - Common Controls 24 VAC Power and Comms Cables  
18865201 - W15-100 Dryer SPI Control Communications Assembly  
18865202 - WMDC15-100 Dryer SPI Control Communications Assembly  
18865203 - W150-5000 Dryer SPI Control Communications Assembly  
18865204 - W15-100 Dryer Modbus Control Communications Assembly  
18865205 - WMDC15-100 Dryer Modbus Control Communications Assembly  
18865206 - W150-500 Dryer Modbus Control Communications Assembly  
18865207 - W15-100 Dryer DeviceNet Control Communications Assembly  
18865208 - WMDC15-100 Dryer DeviceNet Control Communications Assembly  
18865209 - W150-5000 Dryer DeviceNet Control Communications Assembly  
18865210 - W Dryer Ethernet Control Communications Assembly

# Modbus TCP/IP Communications Parameters

Legends:  
 F Floating Point Parameter  
 I Integer Parameter  
 RO Read Only  
 WO Write Only

## Conair Dryer Enhanced Main Control Board

Rev.01

Modbus Address	Type	Description	Default	Range	Recommended for Customer Reads	Recommended for Customer Writes	Comments
40001	I	Dryer Type	1	0 Central Dryer (No process heater) 1 Standard Dryer 2 Unused 3 1-Hopper MDC 4 2-Hopper MDC	Y	N	
40002	I, RO	Control Board Software Version		xxxx base 5 digits = / Small Electric Dryer = / Small Electric Dryer xy Major release zz Minor release	Y	N	
40016	I	Drying Monitor High Alarm Delay	1	0- 30 Min.	Y	Y	
40017	I	Stop Conveying If Shutdown Alarm Active	1	0- No 1- Yes	Y	Y	
40018	I	Delay Time for Stopping Conveying	60	0- 240 Min.	Y	Y	
40020	I	Self Loading Option (Wheel)	0	0- Machine Loader Only	Y	N	
40021	I	Hopper Loader Virgin Load Time (Wheel)	5	2- Ratio Valve + Option1	Y	Y	
40022	I	Hopper Loader Resping Load Time (Wheel)	5	1- 60 Sec.	Y	Y	
40023	I	Hopper Loader Load Time (Wheel)	5	1- 60 Sec.	Y	Y	
40024	I	Layering On/Off (Wheel)	0	0- Off 1- On	Y	Y	
40041	I, RO	Operating Mode	1	0 Power Up 1 Standby 2 Starting 3 Stopping 4 Autotuning 5 Calibrating 6 Running 7 Indexing 8 Index End 9 Index Reset 10 Test Mode	Y	N	
40042	I, RO	Running Status	0	Bit values. MSB=7. LSB=0. This returns the actual running status. Bit value: No = 0 Yes = 1 ----- 0 Ready To Run 1 Hop1 Setback Active 2 60 Sec. Prior to Index 3 PM1 Active 4 Alarm Silenced 5 Shutdown Alarm Active 6 Passive Alarm Active 7 Hop2 Setback Active 8 Booster2 Is Ramping 9 Process Is Ramping 10 Prepoint Control Active 11 Despoint Control Active 12 Pre-Cooler Active	Y	N	

40043	I, RO	Shutdown Alarm Status	0	<p>Bit values, MSB=15, LSB=0. This returns the actual shutdown alarm status. Bit value: Inactive = 0 Active = 1</p> <pre> ===== 0 Process High Temperature 1 Process Temperature Loop Break 2 Process Heater Box High Temperature 3 Process Heater Box High Alarm 4 Process Differential Alarm 5 Regen Heater Box High Temperature 6 Carousel Index Too Long 7 Carousel Index Failure 8 Return Air High Temperature 9 Unused 10 Unused 11 Watchdog Timeout 12 Booster2 Heater Box High Temperature 13 Phase Error 14 Phase Error 15 Process Blower Overload </pre>	Y	N
40044	I, RO	Passive Alarm Status	0	<p>Bit values, MSB=15, LSB=0. This returns the actual passive alarm status. Bit value: Inactive = 0 Active = 1</p> <pre> ===== 0 Process Temperature Deviation 1 Process Low Temperature 2 Regen Temperature Deviation 3 Regen Low Temperature 4 Regen High Temperature 5 Regen Temperature Loop Break 6 Return Air Mid-High Temperature 7 After-Cooler Loop Break 8 Process Dewpoint (PMI) 9 Process Filter Clogged 10 CFM low 11 CFM high 12 Drying Monitor Low Temperature 13 Drying Monitor High Temperature not Met 14 Conveying Alarm 15 MDC Conveying Blower Overload </pre>	Y	N
40045	I, RO	Temp Input Integrity Status	0	<p>Bit values, MSB=7, LSB=0. This returns the actual RTD integrity status. Bit value: Good = 0 Bad = 1</p> <pre> ===== 0 Regen2 Probe 1 Process Probe 2 Regen Temperature Probe 3 Out of Hopper2 Probe 4 Return Air Temperature Probe 5 Process Protection Probe 6 Out of Hopper Probe 7 Regen Out of Wheel Probe 0 to 100% 0 to 100% 0 to 100% 0 to 100% 0 to 1000 min. 0 - 1000 sec. 0 - OFF 1 - T3 2 - T4 3 - T5 4 - T6 0 - 30 minutes 1 - 24 Hours </pre>	Y	N
40101	I	Process Heater Output %	0		Y	N
40111	I	Process with Pre-Cooler Output %	0		Y	N
40139	I	After-Cooler Output %	0		Y	N
40154	I	Regen Heater Output %	0		Y	N
40163	I	DM Alarm Inhibit Time	20		Y	N
40164	I	DM Alarm Delay Time	20		Y	N
40189	I	DMZ Alarm Selection	0		Y	Y
40193	I	DMZ Alarm Delay	5		Y	Y
40194	I	DMZ Temperature not Met Time	4		Y	Y



