

User Guide

Precision Belt Pullers

3-20, 4-26 and 6-39 Models

Installation

Operation

Maintenance

Troubleshooting



*Instant Access
Parts and Service
(800) 458-1960
(814) 437-6861*

www.conairnet.com

CONAIR™

The Conair Group, Inc.
One Conair Drive
Pittsburgh, PA 15202
Phone: (412) 312-6000
Fax: (412)-312-6227

UGE015/0402

Record your equipment's model and serial number(s) and the date you received it in the spaces provided.

It is important to record the model and serial number(s) of your equipment and the date you received it in the User Guide. Our service department uses this information, along with the manual number, to provide help for the specific equipment you installed.

Keep this User Guide and all manuals, engineering prints and parts lists together for documentation of your equipment.

Date:
Document Number: UGE015/0402
Serial number(s):
Model number(s):
Power Specifications: Amps Volts Phase Cycle

DISCLAIMER: The Conair Group, Inc., shall not be liable for errors contained in this User Guide or for incidental, consequential damages in connection with the furnishing, performance or use of this information. Conair makes no warranty of any kind with regard to this information, including, but not limited to the implied warranties of merchantability and fitness for a particular purpose.

TABLE OF CONTENTS

INTRODUCTION	1-1
Purpose of the User Guide	1-2
How the Guide is Organized	1-2
Your Responsibilities as a User	1-2
ATTENTION: Read this so no one gets hurt	1-3
How to Use the Lockout Device	1-5
DESCRIPTION	2-1
What is the Precision Belt Puller?	2-2
Typical Applications	2-2
How It Works	2-3
Precision Belt Puller Features	2-4
Specifications	2-5
Optional Equipment	2-6
INSTALLATION	3-1
Unpacking the Boxes	3-2
Preparing for Installation	3-3
Installing the Puller	3-4
Connecting the Main Power	3-5
Adjusting Belt Tension	3-6
Setting the Belt Gap	3-7
Testing the Installation	3-9
OPERATION	4-1
Start-Up Preparations	4-2
Starting the Puller	4-3
Operation	4-4
Stopping the Puller	4-5
Shutting Down	4-5
MAINTENANCE	5-1
Preventative Maintenance Schedule	5-2
Replacing Belts	5-4
Replacing the Belts (Flat)	5-5
Replacing the Belts (Poly-Vee)	5-6
Lubricating Shafts and Fittings	5-7
Replacing Motor Brushes	5-8
Checking Electrical Connections	5-9

TROUBLESHOOTING6-1

Before Beginning	6-2
A Few Words of Caution	6-2
Identify the Cause of a Problem	6-3
Operation Problems	6-4
Product Quality Problems	6-6

APPENDIX

Customer Service	A-1
Warranty Information	A-2
Belt Adjustment Options	B-1
Using the Digital Belt Gap Sensor	B-1
Adjusting the Pneumatic Upper Belt Actuator	B-2
Choosing Belt Materials	C-1
Conair Belts	C-1

INTRODUCTION

- *Purpose of the User Guide1-2*
- *How the User Guide
is Organized1-2*
- *Your Responsibilities
as a User1-2*
- *ATTENTION: Read this so
no one gets hurt1-3*
- *How to Use the
Lockout Device1-5*

PURPOSE OF THE USER GUIDE

This User Guide describes the Conair Precision Belt Pullers and explains step-by-step how to install, operate, maintain and repair this equipment.

Before installing this product, please take a few moments to read the User Guide and review the diagrams and safety information in the instruction packet. You also should review manuals covering associated equipment in your system. This review won't take long, and it could save you valuable installation and operating time later.

HOW THE USER GUIDE IS ORGANIZED

Symbols have been used to help organize the User Guide and call your attention to important information regarding safe installation and operation.



Symbols within triangles warn of conditions that could be hazardous to users or could damage equipment. Read and take precautions before proceeding.



Numbers within shaded squares indicate tasks or steps to be performed by the user.



A diamond indicates the equipment's response to an action performed by the user.



An open box marks items in a checklist.



A shaded circle marks items in a list.

YOUR RESPONSIBILITY AS A USER

You must be familiar with all safety procedures concerning installation, operation and maintenance of this equipment. Responsible safety procedures include:

- Thorough review of this User Guide, paying particular attention to hazard warnings, appendices and related diagrams.
- Thorough review of the equipment itself, with careful attention to voltage sources, intended use and warning labels.
- Thorough review of instruction manuals for associated equipment.
- Step-by-step adherence to instructions outlined in this User Guide.

We design equipment with the user's safety in mind. You can avoid the potential hazards identified on this machine by following the procedures outlined below and elsewhere in the User Guide.



DANGER: Moving parts; pinch hazard

Safety devices have been installed on this machine to prevent injury that could result from clothing or the operator becoming caught in moving traction belts. Never remove or disable safety devices to sustain production. Operating without these devices could lead to hazardous conditions that can cause severe injury.

- Walk-through style belt guards protect from injury, but also allow side entry for ease of operation. Upper and lower belt guards independently protect the operator from being caught in the belts or associated driven sheaves.
- The power cord is attached to the upper guard by a receptacle on the rear side of the guard. You must disconnect this power cord to remove the upper belt guard, ensuring that the puller will not start if the upper guard is not in place. Units equipped with the optional direct drive system have a guard covering the drive belt.
- The flip up safety switch on the discharge end of the upper belt guard allows operation only when in the down position. If a finger or piece of clothing is caught on the upper belt and drawn in, the guard flips up and immediately shuts off the power to the belt drive.
- The emergency stop (E-stop) button is located on top of the upper belt guard at the upstream end. When pressed, it works in parallel with the flip-up guard to disconnect power to the belt drive. The E-stop must be physically pulled up to reset the switch and start the puller again.

**⚠ ATTENTION:
READ THIS SO NO
ONE GETS HURT**

Continued on next page

**ATTENTION:
READ THIS SO NO
ONE GETS HURT**



WARNING: Improper installation, operation, or servicing may result in equipment damage or personal injury.

This equipment should only be installed, adjusted, and serviced by qualified technical personnel who are familiar with the construction, operation, and potential hazards of this type of machine.

All wiring, disconnects, and fuses should be installed by qualified electrical technicians in accordance with electrical codes in your region. Always maintain a safe ground. Do not operate the equipment at power levels other than what is specified on the machine serial tag and data plate.



WARNING: Voltage Hazard

This equipment is powered by three phase alternating current, as specified on the machine serial tag and data plate.

A properly-sized conductive ground wire from the incoming power supply must be connected to the chassis ground terminal inside the electrical enclosure. Improper grounding can result in severe personal injury and erratic machine operation.

Always disconnect and lockout power before opening the electrical enclosure or performing non-routine procedures such as maintenance.



WARNING: Electrical hazard

Before performing maintenance or repairs on this product, disconnect and lock out electrical power sources to prevent injury from unexpected energization or start-up. A lockable device has been provided to isolate this product from potentially hazardous electricity.

HOW TO USE THE LOCKOUT DEVICE

Lockout is the preferred method of isolating machines or equipment from energy sources. Your Conair product is equipped with the lockout device pictured below. To use the lockout device:

- 1 Stop or turn off the equipment.**
- 2 Isolate the equipment from electrical power.** Turn the rotary disconnect switch to OFF or ON position.
- 3 Secure the device with an assigned lock or tag.**
- 4 The equipment is now locked out.**

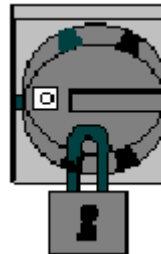

CAUTION: Moving parts

Before removing lockout devices and returning switches to the ON position, make sure that all personnel are clear of the machine, tools have been removed and all safety guards have been reinstalled.

DESCRIPTION

- ***What is the Precision Belt Puller?2-2***
- ***Typical Applications2-2***
- ***How It Works2-3***
- ***Precision Belt Puller***
 - Features2-4***
- ***Specifications2-5***
- ***Optional Equipment2-6***

WHAT IS THE PRECISION BELT PULLER?

Conair Precision Belt Pullers are designed to consistently pull small to medium-sized extruded products through sizing and/or cooling tanks. The standard direct belt drive system is suitable when requiring either higher speeds and lower torque, or extremely good speed control.

The optional vertical drive system on 6-39 with 3 hp motor is suitable for applications requiring relatively high pulling force. The hardened spiral bevel gears protected with high temperature grease makes vertical drive shaft pullers a good choice for high torque, low speed applications.

TYPICAL APPLICATIONS

Conair Precision Belt Pullers can pull extrudable plastics and elastomers both on and off line. These units can pull tubes and profiles up to about 6 inches in diameter through a vacuum sizing tool. Larger sizes may be accommodated for free extrusion processes having little or no drag against a sizing tool.

The belt pullers are limited by the traction length (the length over which the extrusion is in contact with the puller belts), which is fixed for a particular model.

Conair Precision Belt Pullers are available in three sizes:

MODEL	BELT WIDTH	TRACTION LENGTH*
3-20	3 in.	20 in.
4-26	4 in.	26 in.
6-39	6 in.	39 in.

*The approximate length the belts are in contact with each other.

The outer surface of the puller belt material will affect puller performance.

Softer (low durometer) materials provide good 'grab', but will wear more quickly, and may tear if the belt jams. Harder materials last longer, but may not grab the extrusion properly.

Poly-V belts are standard on the Precision Belt Pullers. Other materials are available. See Choosing Belt Materials in the Appendix for more information.



Two opposing belts pull the extrusion through the line based on the speed set at the puller's speed reference potentiometer control.

HOW IT WORKS

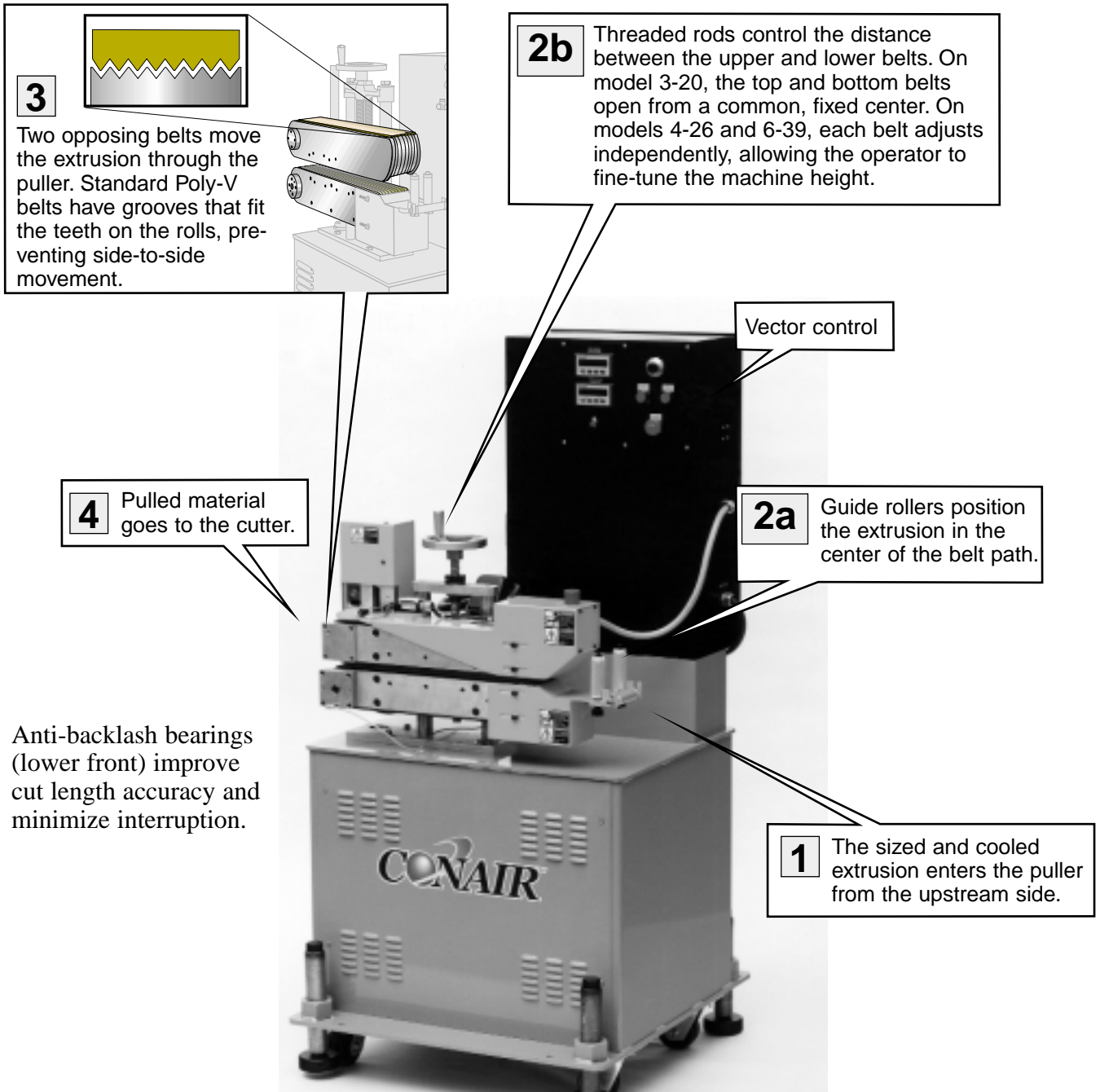

PRECISION BELT PULLER FEATURES

Vector drive is standard and is located inside the control box.

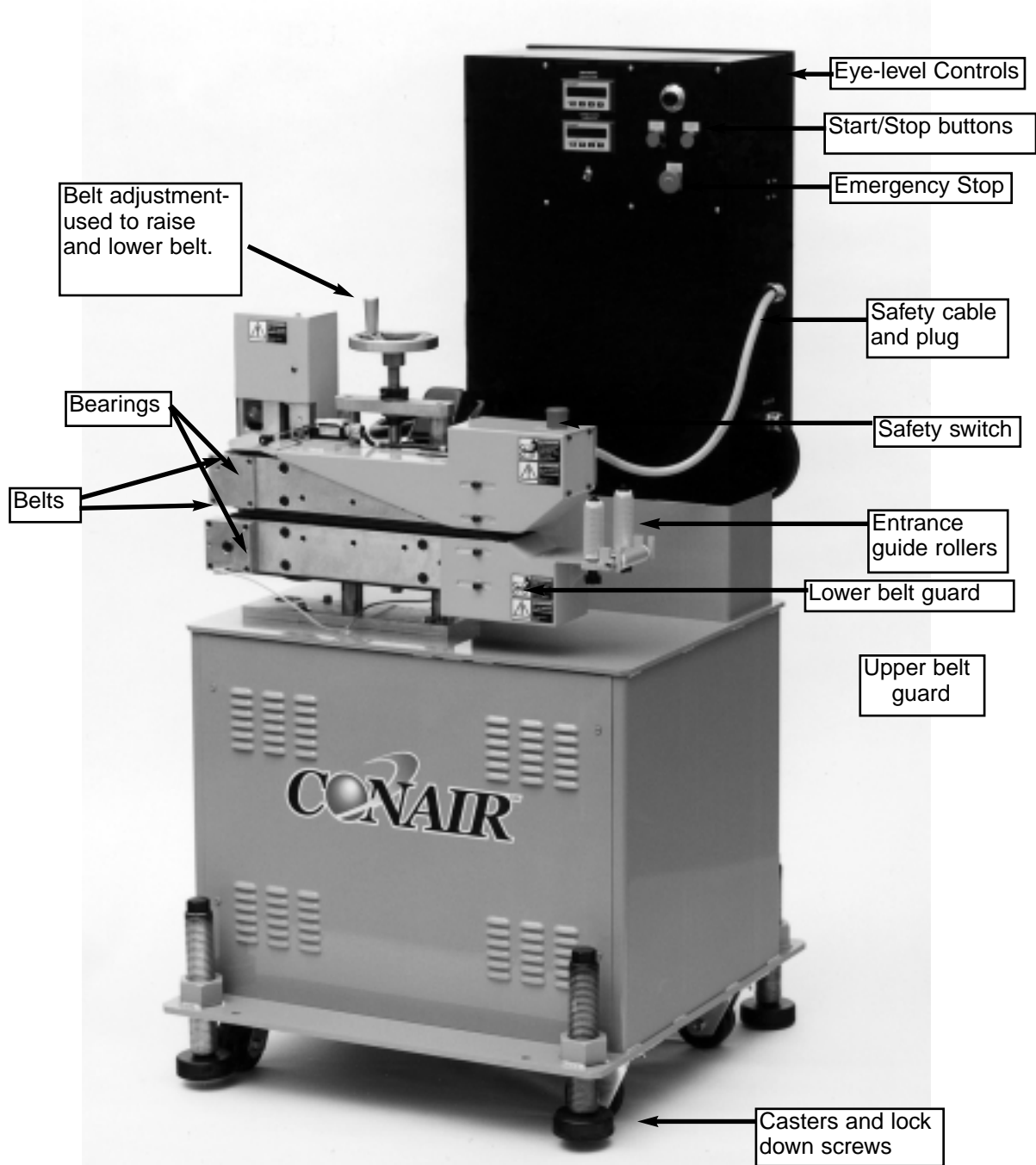

Precision Belt Pullers Models 3-20, 4-26 and 6-39

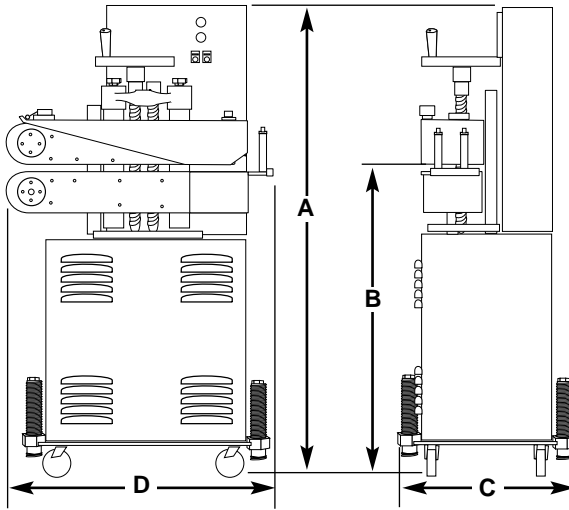

MODELS	3-20			4-26			6-39					
Performance characteristics												
Belt width in. {mm}	3 {76}			4 {102}; optional 6 {152}			6 {152}; optional 8 {203}					
Belt contact length in. {mm}	20 {508}			26 {660}			39 {991}					
Maximum feed opening in. {mm}	4 {102}			5 {127}			7 {178}					
Motor Drives Hp	1.0; optional 1.5			1.5; optional 2.0			1.5 and optional 2.0					
Belt drive	NA			NA			optional 3.0*					
Vertical drive	NA			NA			optional 3.0*					
Belt type†	Poly V, 40/50 durometer natural rubber covering											
Belt speeds - Drive type	open loop vector	closed loop vector	velocity servo drive	open loop vector	closed loop vector	velocity servo drive	open loop vector	closed loop vector	velocity servo			
Available speeds feet/min	2.6 - 80	1.6 - 80	0.8 - 80	1.9 - 59	1.1 - 59	0.5 - 59	1.9 - 59	1.1 - 59	0.59 - 59			
	5.3 - 160	3.2 - 160	1.6 - 160	3.9 - 118	2.3 - 118	1.2 - 118	3.9 - 118	2.3 - 118	1.2 - 118			
	10.6 - 320	6.4 - 320	3.2 - 320	7.8 - 236	4.7 - 236	2.3 - 236	7.8 - 236	4.7 - 236	2.3 - 236			
				15.7 - 472	9.4 - 472	4.7 - 472	15.7 - 472	9.4 - 472	4.7 - 472			
Dimensions inches {mm}												
A - Overall height	62 {1575}			60 {1524}			60 {1524}					
B - Height to centerline	42 ±2 {1016 ±50.8}			42 ±2 {1067 ±50.8}			42 ±2 {1016 ±50.8}					
C - Width	34 {864}			34 {864}			37 {940}					
D - Length	34 {864}			34 {864}			50 {1270}					
Weight lb {kg}												
Installed	840 {381}			920 {417}			1410 {639}					
Shipping	990 {449}			1070 {485}			1560 {707}					
Electrical requirements Full Load Amps‡												
Drive type	Open loop		Closed loop		Open loop		Closed loop		Open loop		Closed loop	
	1 Hp	1.5 Hp	1 Hp	1.5 Hp	1.5 Hp	2 Hp	1.5 Hp	2 Hp	2 Hp	3 Hp	2 Hp	3 Hp
230V/3 phase/60 Hz	5.9	10	8.4	10.4	10	10	10.4	12.9	10	13.5	12.9	12.9
460V/3 phase/60 Hz	3.8	6.6	3.3	3.4	6.6	6.6	3.4	5.7	6.6	9.5	5.7	8.6

SPECIFICATION NOTES:

Specifications can change without notice. Contact a Conair representative for the most current information.

* See chart to the right to select drive type and belt speed range for the optional 3 Hp motor drive on Model 6-39.

† Flat belts are available as an option. Optional belt coverings include: 40, 55 and 70 durometer natural rubber; and 60 durometer white nitrile (FDA).

‡ Amp draws increase for the optional 3 Hp drive motor available on Model 6-39.

Optional belt speeds for 3 Hp motor drive on Model 6-39

Drive Type	open loop vector	closed loop vector
available speeds	2.0 - 60	1.2 - 60
feet/min	2.6 - 80	1.6 - 80
	4.0 - 120	2.4 - 120
	8.0 - 240	4.8 - 240

OPTIONAL EQUIPMENT

- **Vertical shaft drive (3 Hp 6-39 Model only)**
With this option, the traction assembly is driven by a reducer mounted in the base connected to a vertical shaft (stress-proof hex shaft) driving the spiral bevel gear reducer mounted to the traction assembly.
- **Digital belt gap sensor and readout**
This option allows the operator to set a zero point, then measure belt gap (in thousandths) relative to this point.
- **Pneumatic upper belt actuator**
An air cylinder assembly that can raise and lower the upper belt boom assembly is available on 4-26 and 6-39 models.
- **Remote belt speed control**
This option allows puller speed control at a remote location, usually at the extruder. Available in 2 variations, with up/down scroll buttons or with digital speed display.
- **Electronic totalizing footage counter**
This option allows the operator to view how much product has passed through the puller based on input from an encoder. The counter may be zeroed at any time.
- **Different reducer ratios**
A particular reducer ratio is selected at the time of purchase to optimize puller performance in a particular speed range.
- **Left-to-right machine operation**
This option changes the machine direction from the standard right to left extrusion flow.

See the Appendix and related manufacturer's manuals for additional information regarding these options.

- **Digital line rate indicator**
Programmable for inches or feet per minute readout.
- **Velocity controlled Servo drive package**
2.46 HP continuous rated servo. Serial operator interface with digital line speed indication. 100:1 speed range with extreme speed holding capabilities.

OPTIONAL EQUIPMENT

- **High precision flat belts with upgraded idler rolls**
Recommended for precision cutting applications, especially when using flywheel modes.
- **High speed modified units (4-26 model only)**
(For speeds above 472 feet per minute)
(With this option belt contact will be slightly reduced)
Includes: Precision flat belt option.

Drive upgrade in Servo versions:

8-800 feet per minute (direct drive 5:1 belt reduction)

14-1400 feet per minute (direct drive 3:1 belt reduction)

20-2000 feet per minute (direct drive with 2 independent velocity controlled Servo drives with serial operator interface and precision flat belt option).
- **Transformer for voltages other than 230**

INSTALLATION

- *Unpacking the Boxes3-2*
- *Preparing for Installation3-3*
- *Installing the Puller3-4*
- *Connecting the Main Power3-5*
- *Adjusting Belt Tension3-6*
- *Setting the Belt Gap3-8*
- *Testing the Installation3-9*

UNPACKING THE BOXES



CAUTION: Lifting hazard

To avoid personal injury or damage to the puller, lift the puller using a forklift or hoist with straps that have been positioned at the puller's center of gravity.



- 1** **Carefully uncrate the puller and its components.** The Belt Puller comes fully assembled in a single crate.
- 2** **Remove all packing material,** protective paper, tape, and plastic. Compare contents to the shipping papers to ensure that you have all the parts.
- 3** **Carefully inspect all components** to make sure no damage occurred during shipping. Check all wire terminal connections, bolts, and any other electrical connections, which may have come loose during shipping.
- 4** **Record serial numbers and specifications** in the blanks provided on the back of the User Guide's title page. This information will be helpful if you ever need service or parts.
- 5** **You are now ready to begin installation.** Complete the preparation steps on the next page.



WARNING: Improper installation, operation, or servicing may result in equipment damage or personal injury.

This equipment should only be installed, adjusted, and serviced by qualified technical personnel who are familiar with the construction, operation, and potential hazards of this type of machine.

All wiring, disconnects, and fuses should be installed by qualified electrical technicians in accordance with electrical codes in your region. Always maintain a safe ground. Do not operate the equipment at power levels other than what is specified on the machine serial tag and data plate.

PREPARING FOR INSTALLATION

You will install the puller on the extrusion line, downstream of the extruder and any calibration/sizing equipment.

1 Make sure the installation area provides:

- A grounded power source** supplying the correct current and voltage. Check the serial tag for the correct amps, voltage, phase and cycles. All wiring should be completed by qualified personnel and should comply with your region's electrical codes.
- Minimum clearance for safe operation and maintenance.** Allow at least 12 to 24 inches (305 to 610 mm) between the downstream end of sizing or cooling tanks and the upstream end of the puller to roll the tank away from the extruder for maintenance. Allow at least 36 inches clearance in front and back of the puller for maintenance access to electrical and mechanical systems.

2 Determine the correct position for the puller.

The puller will be positioned downstream of the extruder and any sizing equipment, and upstream of the cutter. You must consider optional equipment and product type to determine the best spacing between the equipment.

- **For flexible products**, the puller should be as close as possible to the cutter.
- **For rigid products**, leave enough space between the puller and the cutter to allow the product to flex during the cutting cycle. It may be necessary to allow 6-8 feet between the puller and cutter.
- **When operating with an optional laser gauge or diameter gauge**, allow 1 to 2 feet (305 to 610 mm) between the laser gauge and the puller.

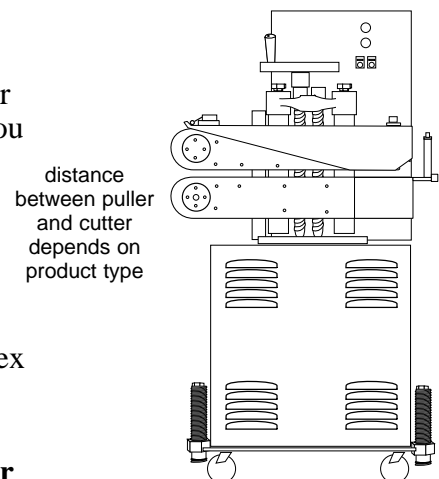

distance between puller and cutter depends on product type

12 to 24 inches between puller and laser gauge or sizing equipment

INSTALLING THE PULLER

Tools for installation:

- 16- or 18-inch adjustable wrench
- Set of Allen wrenches



CAUTION: Lifting hazard

To avoid personal injury or damage to the puller, lift the puller using a forklift or hoist with straps that have been positioned at the puller's center of gravity.

- 1 Move the puller into position.** Place the belt puller downstream of the extruder and upstream of the cutter in the position determined during preparation.

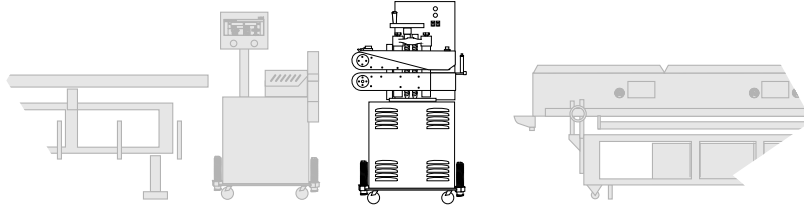

- 2 Measure the centerline height** of the extruded product as it exits the extrusion line. Make sure all equipment on the extrusion line is aligned to this height. Use a plumb line or laser to check for a straight line from the extrusion die through each line component.

- 3 Align the puller with the centerline height of the extrusion line.** Adjust the puller's floor lock/caster assembly to the center height of the extrusion line using a 16- or 18-inch adjustable wrench. Turn the floor locks until the puller reaches the center height of the extrusion line.

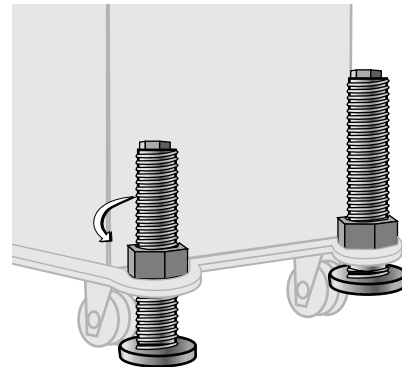

IMPORTANT: Never operate the puller on casters. Always use the leveling jacks to support the puller. Once the correct height is reached, adjust the pad assembly to remove the weight from the casters.

- 4 Adjust the belt puller entrance guide rollers** to insure consistent guidance of the product along the centerline.

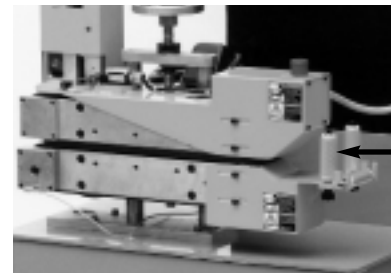

Entrance guide rollers

CONNECTING THE MAIN POWER SOURCE



WARNING: Electrical hazard

Before performing any work on this product, disconnect and lock out electrical power sources to prevent injury from unexpected energization or start-up. A lockable device has been provided to isolate this product from potentially hazardous electricity.



WARNING: Improper installation, operation, or servicing may result in equipment damage or personal injury.

This equipment should only be installed, adjusted, and serviced by qualified technical personnel who are familiar with the construction, operation, and potential hazards of this type of machine.

All wiring, disconnects, and fuses should be installed by qualified electrical technicians in accordance with electrical codes in your region. Always maintain a safe ground. Do not operate the equipment at power levels other than what is specified on the machine serial tag and data plate.

1 Open the puller's electrical enclosure.

Turn the disconnect dial on the door to the OFF or O position and open the door.



2 Insert the main power wire through the knockout in the side of the enclosure. Secure the wire with a rubber compression fitting or strain relief.

3 Connect the power wires to the three terminals indicated on the wiring diagram that came with your machine.

4 Check every terminal screw

to make sure wires are secure. Gently tug each wire. If a wire is loose, use a screwdriver to tighten the terminal.

5 Connect the ground wire to either grounding point shown in the wiring diagram.

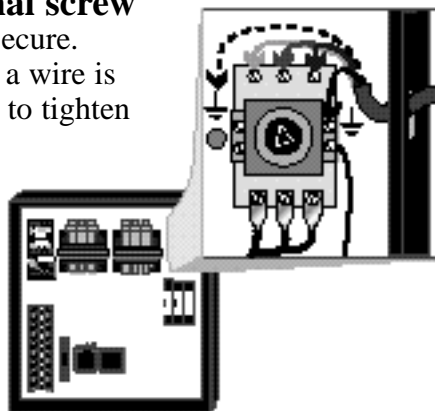

IMPORTANT: Always refer to the wiring diagrams that came with your belt puller before making electrical connections. The diagrams show the minimum size main power cable required for your puller, and the most accurate electrical component information.

ADJUSTING BELT TENSION

1 Turn the main power disconnect to the off position.

2 Remove the belt guards.

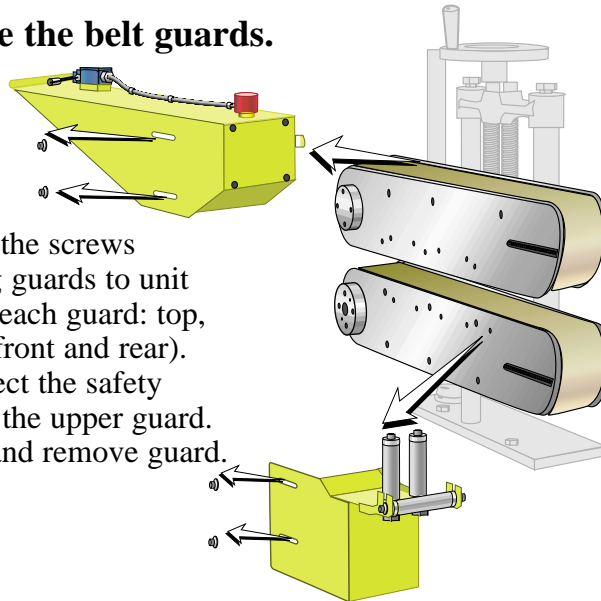

Remove the screws attaching guards to unit (four on each guard: top, bottom, front and rear). Disconnect the safety cable on the upper guard. Lift off and remove guard.

3 **Check belt tension.** Belts should be just tight enough to prevent slipping, and the gap between the upper and lower belts should be even across the width of the belt.

NOTE: Loose belts cause belt and product to slip; over-tightened belts result in distorted product and can lead to premature bearing failure.

4 **Adjust belt tension, if necessary.** Adjust tension by turning the threaded tension rods. Keep tension on front and back edges, top and bottom belts as even as possible.

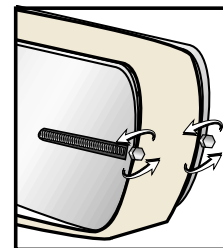

Check for belt alignment by measuring the distance between the idler shaft and the steel blocks that the adj. bolts are against. Make sure they both are the same from one side to the other.

ADJUSTING BELT TENSION

5 Fine tune tension:

- **Lower the belts** to a gap of about 1/8 in. (3 mm). (See Setting the Belt Gap)
- **Check the appearance of the belt gap.** From the upstream end, look down the length of the belts. The shape of the gap should not be concave (overtightened) or convex (too loose). Adjust the tension until the gap is even and measures 1/8 in.
- **Check tension and readjust as necessary.**

6 For flat belts only:

- **Open the beam** all the way.
- **Turn the speed down** to about 10 ft/per min.
- **Have your socket wrench ready.**
- **Turn the puller on** and watch the edge of the belt and the gap between the sides of the beam. They should be the same. If the belt starts to run to one side or the other, adjust accordingly so the belt is running in the center of the pulley.



Warning: Keep hands and face clear of belts.

SETTING THE BELT GAP

The belt gap should be set to the dimensions of the extruded product, being careful not to make the gap so small that the pressure causes distortion in the product.

For the 3-20 puller

The upper and lower belt boom assemblies are controlled by a common threaded rod. The upper and lower belts move away from each other or toward each other as the hand wheel is turned.

- 1 **Turn the hand wheel** until the gap between the belts reaches the desired distance.

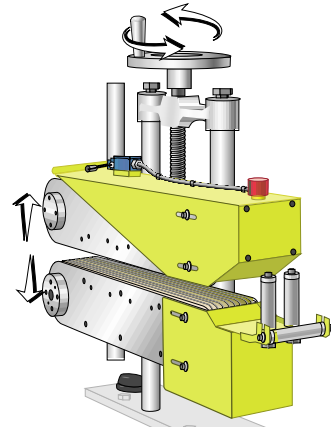

For the 4-26 and 6-39 pullers

Each belt boom assembly is moved separately. A single handle is used for both threaded rods.

To move the handle from one rod to the other, lift it and place it on the other shaft. You may have to rotate it slightly to engage the keyway with the key on the shaft.

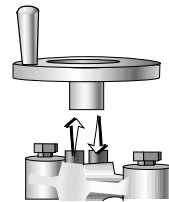

- 1 **To raise or lower the upper belt:**

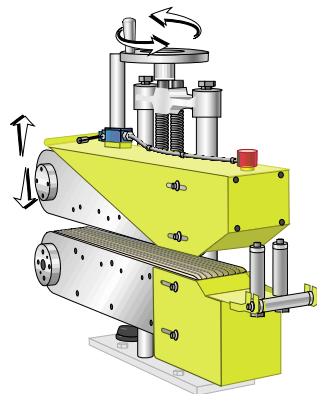

Place the hand wheel on the threaded knob at the left and turn.

- 2 **To raise or lower the lower belt:**

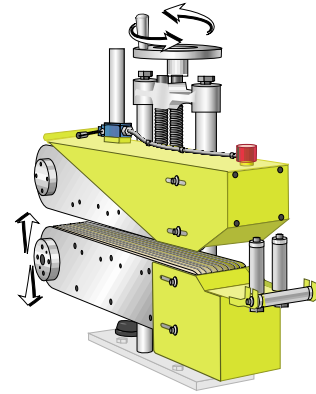

Place the hand wheel on the threaded knob at the right and turn.

NOTE: See the Appendix for instructions on using the optional Pneumatic Upper Belt Actuator to position the upper belt.



DANGER: Pinch Hazard

Never remove or disable safety devices to sustain production. Operating without these devices could lead to hazardous conditions that can cause severe injury. Take all necessary precautions when working around moving parts to prevent body parts and clothing from being pulled into the machine.

TESTING THE INSTALLATION

- 1** **Make sure all components** are installed according to assembly drawings. Check all bolts on the puller for tightness.
- 2** **Check that puller is firmly anchored** into position with the floor locks.
- 3** **Check that all wiring conforms to electrical codes**, and all wiring covers are in place.
- 4** **Turn on the main disconnect.** Plug in the main power cord and turn on the main disconnect.
- 5** **Check that the E-Stop button is in the out, extended position.**
- 6** **Press Start button.** The belts should begin to rotate.

If the puller is not working properly at any time, turn it off immediately and refer to the Troubleshooting section of this User Guide.

If you do not encounter any problems, proceed to the Operation section.

OPERATION

- *Start-Up Preparations*4-2
- *Starting the Puller*4-3
- *Operation*4-4
- *Stopping the Puller*4-5
- *Shutting Down*4-5

START-UP PREPARATIONS



WARNING: Improper installation, operation, or servicing may result in equipment damage or personal injury.

This equipment should only be installed, adjusted, and serviced by qualified technical personnel who are familiar with the construction, operation, and potential hazards of this type of machine.

All wiring, disconnects, and fuses should be installed by qualified electrical technicians in accordance with electrical codes in your region. Always maintain a safe ground. Do not operate the equipment at power levels other than what is specified on the machine serial tag and data plate.

- 1** **Locate puller on the extrusion line** with the floor support pads adjusted to the product centerline.

Note: Never operate belt puller on casters only.

- 2** **Be sure power supply matches** specified belt puller power before connecting. If unsure, please do not hesitate to call the factory.
- 3** **Adjust the belt puller** entrance guide rolls to insure consistent product guidance.
- 4** **Adjust the belt** opening to allow consistent traction to the product without deformation.



DANGER: Moving Parts Hazard

Take all necessary precautions when working around moving parts to prevent body parts and clothing from being pulled into the machine.

Always disconnect and lock out the main power source before performing maintenance on the puller.

Never remove or disable safety devices to sustain production. Operating without these devices could lead to hazardous conditions that can cause severe injury.

STARTING THE PULLER

Before you start daily operation of the puller, you should:

- Inspect the puller belts.
- Check puller alignment with the extrusion line.
- Assure the floor locks are properly engaged.
- Thread the extrudate through the sizing equipment, puller and an other devices on the extrusion line puller.

See the *MAINTENANCE* section of this User Guide for detailed information on daily maintenance procedures.

- 1 Plug in the power cord** to restore power after any required maintenance.
- 2 Turn on power to the puller.** Plug in the power cord to restore power after performing any required maintenance. Turn the main disconnect to the ON position.
- 3 Press the green Start button.** If the puller does not start, make sure the E-stop button pulled out in the extended position.
- 4 Rotate the speed reference** potentiometer to adjust belt speed.
- 5 Observe the digital line** rate indicator to observe line speed. (optional)

OPERATION

1 Apply power to the machine.
Place the disconnect in the “ON” position.

2 Check to insure to 10-turn speed potentiometer
is turned to zero speed. (Counter-clockwise fully).

Note: Whenever the puller is turned off, the speed potentiometer should be rotated to zero speed. In this way, when the unit is started, it will be in a safe operational mode.

3 Open the gap between the puller belts to the desired gap for the product to be pulled.

4 Depress the green “START” button to start the drive.

Note: If the puller does not start, make sure the “E-Stop” button is pulled out in the extended position.

5 Using the 10-turn potentiometer, adjust the puller speed.

Note: Turn in a clockwise direction to increase speed and counter-clockwise to decrease speed.

6 A digital line rate indicator (optional) can be used to set the desired puller speed.

Note: This display should be programmed in feet per minute, with one decimal point (tenths of feet per minute), unless otherwise specified.



WARNING: Safe Stopping

Do not use any part of the guard circuit or the rotary disconnect to stop the belt puller. Use the recommended procedure to assure a safe stopping.

STOPPING THE PULLER

- 1** Remove extrudate from the puller.
- 2** Press the red Stop button.
- 3** Turn rotary disconnect to OFF.
- 4** Rotate the 10-turn potentiometer to zero speed.
Note: Always start puller with potentiometer set at zero (0).

To shut down the puller, perform the stopping procedure listed above. No additional steps are necessary if the puller is shut down for short period of time.

If the puller is shut down for an extended period of time, belts can acquire “set.” If this occurs, let the puller run for 20-30 minutes before use. This should remove any set from the belts.

SHUTTING DOWN

MAINTENANCE

- ***Preventative Maintenance Schedule***5-2
- ***Replacing Belts***5-4
- ***Replacing the Belts (Flat)***5-5
- ***Replacing the Belts (Poly-Vee)***5-6
- ***Lubricating Shafts and Fittings***5-7
- ***Replacing Motor Brushes***5-8
- ***Checking Electrical Connections***5-9

PREVENTATIVE MAINTENANCE SCHEDULE



WARNING: Moving Parts. Improper servicing may result in equipment damage or personal injury.



This equipment should be adjusted and serviced by qualified technical personnel who are familiar with the construction, operation, and potential hazards of this type of machine.

Before performing maintenance or repairs on this product, disconnect and lock out electrical power sources to prevent injury from unexpected energization or start-up. A lockable device has been provided to isolate this product from potentially hazardous electricity.

Make sure all safety devices and belt guards are installed before resuming normal operation.

To maintain the best performance of the puller, we recommend the following maintenance schedule. You may need to shorten the time between servicing, depending on how often you use the belt puller, and the types of material flowing through it. Maintenance should be performed anytime you change materials, lines or equipment in the extrusion line.

● Daily

Inspect puller belts for wear.

If a belt shows sign of cracks, tears, or other damage, replace it. See *REPLACING BELTS*.

Check the puller belt tension and belt gap.

See *ADJUSTING THE BELT TENSION* and *SETTING THE BELT GAP* in the *INSTALLATION* section.

Verify puller alignment.

Proper alignment with other equipment on the line is critical for optimum performance. Use a plumb line or laser to check for a straight line from the extrusion die to the cutter bushings.

Verify floor lock settings.

The weight of the puller should never rest on the casters during operation. For stability during pulling and cutting cycles, the puller should rest on the floor locks and pad assembly. Verify that the floor locking mechanism is properly adjusted before starting the puller. If necessary, use a 16- or 18-inch adjustable wrench to turn the floor locks until the weight is off the casters and the puller reaches the center height of the extrusion line.

PREVENTATIVE MAINTENANCE SCHEDULE

● Weekly

- ❑ **Check shaft and grease fittings.**
See *LUBRICATING SHAFT AND FITTINGS.*

● Monthly

- ❑ **Inspect motor brushes**
Inspect the motor brushes for wear. Replace, if needed.
See *REPLACING MOTOR BRUSHES.*

● Semiannual (every 6 months)

- ❑ **Check electrical cables and terminals.**
Inspect all electrical terminals for tightness. Inspect all electrical cables for cuts and abrasions. Replace any damaged cables or electrical connections.
See *CHECKING ELECTRICAL CONNECTIONS.*
- ❑ **Inspect control panel lights.**
Check to make sure no LEDs or lights are burned out on the control panel. Replace as needed.

REPLACING THE BELTS FLAT



WARNING: Moving Parts.
Improper servicing may result in
equipment damage or personal injury.



This equipment should be adjusted and serviced by qualified technical personnel who are familiar with the construction, operation, and potential hazards of this type of machine.

Before performing maintenance or repairs on this product, disconnect and lock out electrical power sources to prevent injury from unexpected energization or start-up. A lockable device has been provided to isolate this product from potentially hazardous electricity.

Make sure all safety devices and belt guards are installed before resuming normal operation.

1 Turn the main power disconnect to the off position.

2 Remove the belt guards.

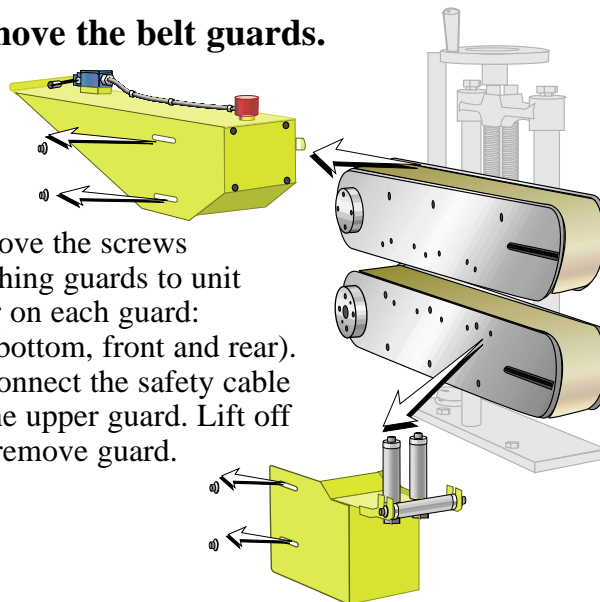

Remove the screws attaching guards to unit (four on each guard: top, bottom, front and rear). Disconnect the safety cable on the upper guard. Lift off and remove guard.

3 Release the belt tension.

Loosen the threaded rods, making sure you keep tension on front and back edges as even as possible. Turn each rod 5 to 10 revolutions, then switch to the other side. Continue until the belt is loose enough to slide off the puller.

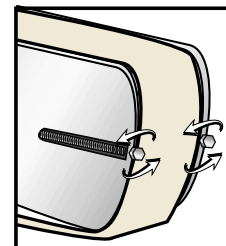

Continued on next page

REPLACING THE BELTS FLAT

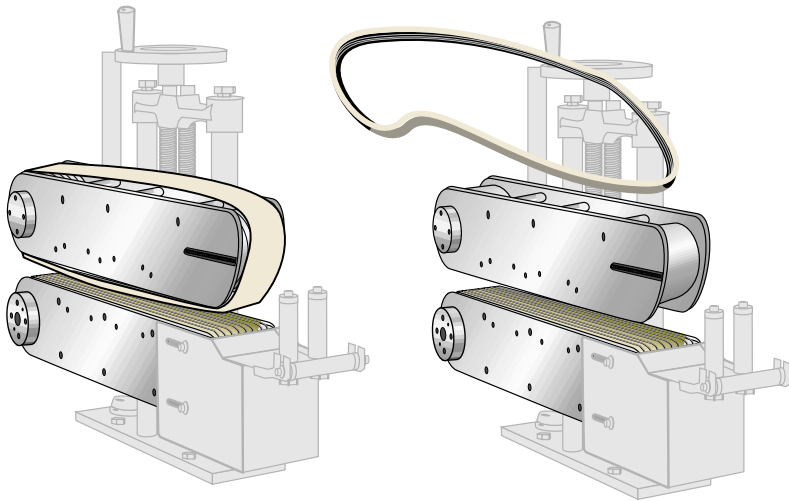

- 4 Remove the belts from the puller.** Check the rollers and pulleys for buildup. Clean if necessary.

- 5 Reverse the process to install the new belts.** Make sure the belts fit properly on the pulleys. Keep tension on front and back sides of the belt as even as possible while tightening the belt tension. Turn each rod 5 to 10 revolutions, then switch to the other side.

- 6 Adjust belt tension and belt gap.** See *ADJUSTING THE BELT TENSION* and *SETTING THE BELT GAP* in the *INSTALLATION* section.

- 7 Reinstall the upper and lower belt guards.**

REPLACING THE BELTS POLY-VEE



WARNING: Moving Parts.
Improper servicing may result in
equipment damage or personal injury.



This equipment should be adjusted and serviced by qualified technical personnel who are familiar with the construction, operation, and potential hazards of this type of machine.

Before performing maintenance or repairs on this product, disconnect and lock out electrical power sources to prevent injury from unexpected energization or start-up. A lockable device has been provided to isolate this product from potentially hazardous electricity.

Make sure all safety devices and belt guards are installed before resuming normal operation.

1 Turn the main power disconnect to the off position.

2 Remove the belt guards.

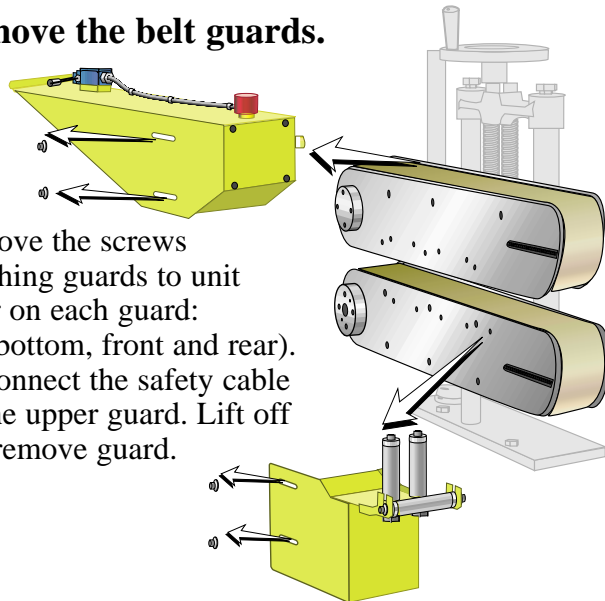

Remove the screws attaching guards to unit (four on each guard: top, bottom, front and rear). Disconnect the safety cable on the upper guard. Lift off and remove guard.

3 Release the belt tension.

Loosen the threaded rods, making sure you keep tension on front and back edges as even as possible. Turn each rod 5 to 10 revolutions, then switch to the other side. Continue until the belt is loose enough to slide off the puller.

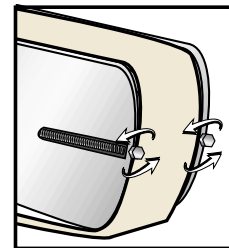

Continued on next page

REPLACING THE BELTS POLY-VEE

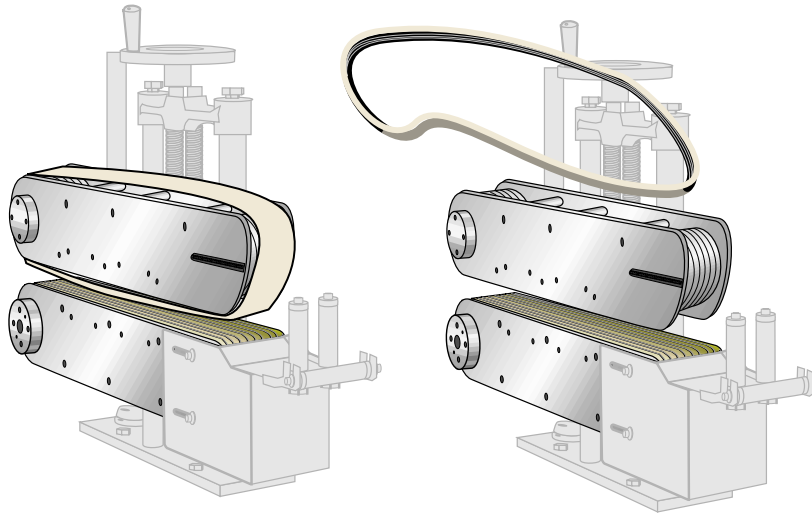

4 Remove the belts from the puller. Check the rollers and pulleys for buildup, especially inside grooves. Clean if necessary.

5 Reverse the process to install the new belt.

Make sure ribs inside the belt fit properly into grooves. Keep tension on front and back sides of the belt as even as possible while tightening the belt tension. Turn each rod 5 to 10 revolutions, then switch to the other side.

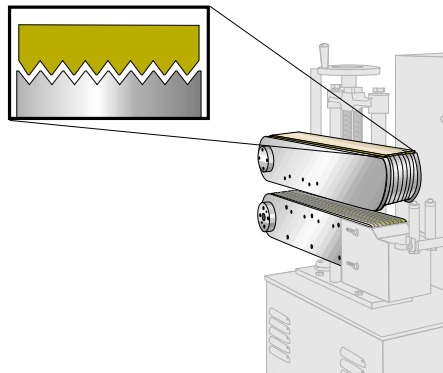

6 Adjust belt tension and belt gap. See *ADJUSTING THE BELT TENSION* and *SETTING THE BELT GAP* in the *INSTALLATION* section.

7 Reinstall the upper and lower belt guards.

LUBRICATING SHAFTS AND FITTINGS

You should check the shafts and grease fittings weekly, and lubricate as needed

Lubricate thread rods and optional vertical shafts with Never-Seize or an equivalent lubricant.

Lubricate the optional vertical shaft drive boxes with a high-temperature grease, such as Mobil grease 28 or an equivalent.

You can use regular grease on all other locations.

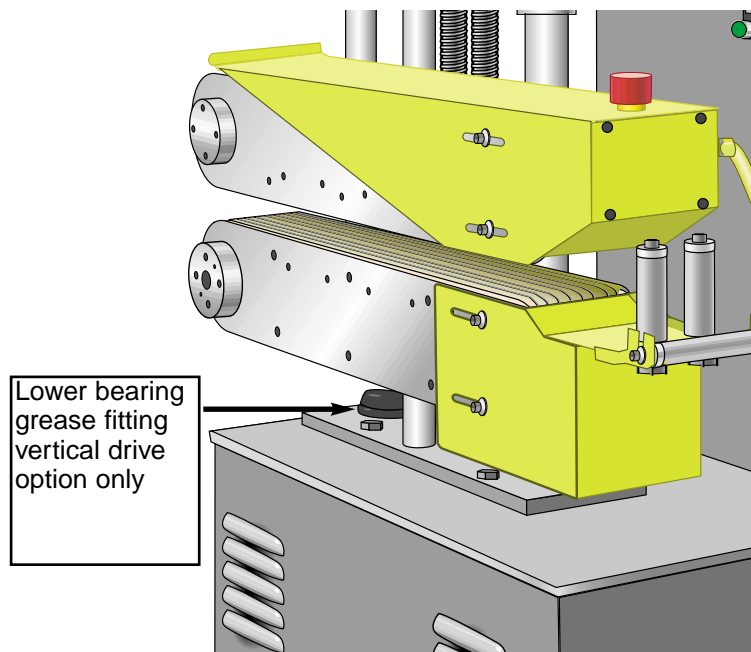
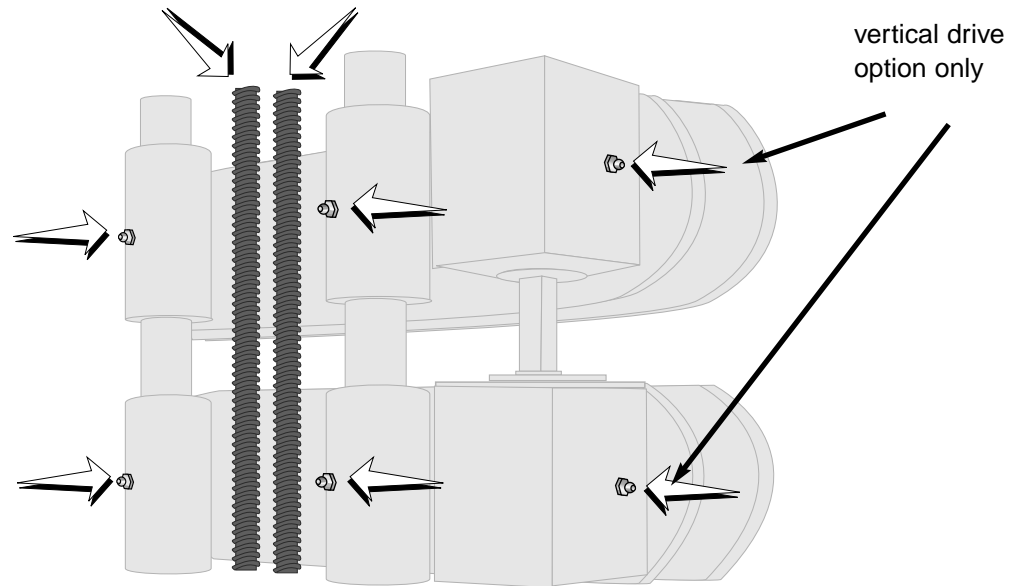

Check the motor brushes. If one or both is less than 1/4 in. long, replace **both** brushes.

To replace the motor brushes:

- 1 Turn the rotary disconnect to OFF.**
- 2 To access the brushes, loosen the screws holding the access covers on each side of the motor housing and remove the covers.**

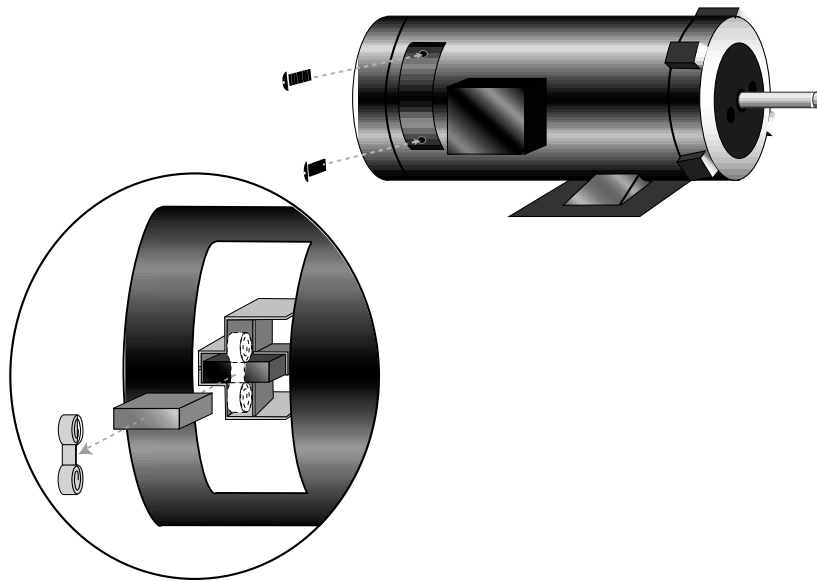

- 3 Remove the spring clips.**
- 4 Examine the brushes.**
If one or both of the brushes are less than 1/4 in. long, replace **both** brushes.
- 5 Replace the covers.**

REPLACING MOTOR BRUSHES OPTION - APPLIES FOR DIRECT CURRENT (DC) MOTORS ONLY

NOTE: AC motors do not have brushes. This includes AC invertors, AC vector and AC servo motors.

CHECKING ELECTRICAL CONNECTIONS



WARNING: Electrical hazard

Before performing any work on this product, disconnect and lock out electrical power sources to prevent injury. A lockable device has been provided to isolate this product from potentially hazardous electricity.



WARNING: Improper servicing may result in equipment damage or personal injury.

This equipment should only be adjusted, and serviced by qualified technical personnel who are familiar with the construction, operation, and potential hazards of this type of machine.

All wiring, disconnects, and fuses should be installed by qualified electrical technicians in accordance with electrical codes in your region. Always maintain a safe ground. Do not operate the equipment at power levels other than what is specified on the machine serial and data plate.

- 1 Disconnect and lock out the main power.**
Turn the main power disconnect to the off position before opening the electrical enclosure on the back of the puller. This is a safety device to prevent you from opening the doors if the power is still on.
- 2 Open the electrical enclosure.**
- 3 Inspect all wires and connections.** Look for loose wires, burned contacts, and signs of over-heated wires. Have a qualified electrician make any necessary repairs or replacements.
- 4 Close the electrical enclosure door.**
- 5 Inspect the exterior power cords.** Cords should not be crimped, exposed, or rubbing against the frame. If the main power cord runs along the floor, make sure it is not positioned where it could rest in pooling water or could be run over and cut by wheels or casters.

TROUBLESHOOTING

● *Before Beginning*6-2

● *A Few Words of Caution*6-2

Diagnostics

● *Identifying the Cause
of a Problem*6-3

● *Operation Problems*6-4

● *Product Quality Problems*6-6

BEFORE BEGINNING

You can avoid most problems by following the recommended installation, operation and maintenance procedures outlined in this User Guide. If you have a problem, this section will help you determine the cause and tell you how to fix it.

Before you begin troubleshooting:

- Find any wiring, parts, and assembly diagrams that were shipped with your equipment. These are the best reference for correcting a problem. The diagrams will note any custom features or options not covered in this User Guide.
- Verify that you have all instructional materials related to the puller. Additional details about troubleshooting and repairing specific components are found in these materials.
- Check that you have manuals for other equipment connected in the system. Troubleshooting may require investigating other equipment attached to, or connected with the puller.

A FEW WORDS OF CAUTION



WARNING: Improper servicing may result in equipment damage or personal injury.

This equipment should only be installed, adjusted, and serviced by qualified technical personnel who are familiar with the construction, operation, and potential hazards of this type of machine.

All wiring, disconnects, and fuses should be installed and adjusted by qualified electrical technicians in accordance with electrical codes in your region. Always maintain a safe ground. Do not operate the equipment at power levels other than what is specified on the machine serial tag and data plate.



WARNING: Electrical hazard

Before performing maintenance or repairs on this product, disconnect and lock out electrical power sources to prevent injury from unexpected energization or start-up. A lockable device has been provided to isolate this product from potentially hazardous electricity.

IDENTIFYING THE CAUSE OF A PROBLEM

The Troubleshooting section covers problems directly related to the operation and maintenance of the standard belt puller. This section does not provide solutions to problems that originate with other equipment. Additional troubleshooting help can be found in manuals supplied with the other equipment.

The main problems you will see with the pullers are:

- **Puller operation problems**, which focus on problems that are clearly related to the puller's mechanical components and electrical control system.
- **Product quality concerns**, which deal with extrudate characteristics that may be related to puller operation. Of course, other sections of the extrusion line also influence the quality of the extruded product. This section does not provide solutions to problems originating with other equipment on the extrusion line.

Additional troubleshooting help can be found in the component manuals included with this User Guide.

OPERATION PROBLEMS

Look in this section when the control or motor is not working properly.

Symptom	Possible cause	Solution
◆ The puller 'creaks' while running.	The belt is too tight.	Check the belt tension; loosen if necessary. See <i>ADJUSTING BELT TENSION in the INSTALLATION section.</i>
	The bearings are failing.	Replace the bearings.
◆ The puller does not start.	The E-stop button is pushed in.	Pull out the E-stop button. Make sure it clicks into position.

Look in this section when the extrudate shows annular rings in the cross-sectional cut of the product.

PRODUCT QUALITY PROBLEMS

Symptom	Possible cause	Solution
◆ Annular rings present on the extrudate.	The belt puller is too close to the cutter.	If the extrudate is interrupted (stopped during processing), annular rings can develop, especially on a thin-walled product. Slightly increase the distance between the puller and the cutter, and test the product until the distance is correct.
	The anti-backlash bearings are not working properly.	Stop the puller and try to move the lower belt by hand. The lower belt should not be able to travel backwards when you try to move it. If it does, the anti-backlash bearings must be replaced. Contact Conair Service.
◆ Wall thickness fluctuation on the extrudate.	There are variations in the speed of the puller.	Check: <ul style="list-style-type: none"><input type="checkbox"/> If motor brushes are worn.<input type="checkbox"/> The belts for cracks and wear. Replace as necessary.<input type="checkbox"/> For material buildup under the belts. Clean as needed.<input type="checkbox"/> The bearings for wear; replace as needed.
◆ Diameter fluctuation on the extrudate.	There are variations in the speed of the puller.	Check: <ul style="list-style-type: none"><input type="checkbox"/> For material buildup under the belts. Clean as needed.<input type="checkbox"/> The bearings for wear; replace as needed.<input type="checkbox"/> If motor brushes are worn.<input type="checkbox"/> The belts for cracks and wear. Replace as necessary.

Conair has made the largest investment in customer support in the plastics industry. Our service experts are available to help with any problem you might have installing and operating your equipment. Your Conair sales representative also can help analyze the nature of your problem, assuring that it did not result from misapplication or improper use.

WE'RE HERE TO HELP

To contact Customer Service personnel, call:



HOW TO CONTACT CUSTOMER SERVICE

From outside the United States, call: 814-437-6861

You can commission Conair service personnel to provide on-site service by contacting the Customer Service Department. Standard rates include an on-site hourly rate, with a one-day minimum plus expenses.

If you do have a problem, please complete the following checklist before calling Conair:

- Make sure you have all model, serial and parts list numbers for your particular equipment. Service personnel will need this information to assist you.
- Make sure power is supplied to the equipment.
- Make sure that all connectors and wires within and between loading control and related components have been installed correctly.
- Check the troubleshooting guide of this manual for a solution.
- Thoroughly examine the instruction manual(s) for associated equipment, especially controls. Each manual may have its own troubleshooting guide to help you.
- Check that the equipment has been operated as described in this manual.
- Check accompanying schematic drawings for information on special considerations.

BEFORE YOU CALL ...

Additional manuals and prints for your Conair equipment may be ordered through the Customer Service or Parts Departments for a nominal fee.

EQUIPMENT GUARANTEE

Conair guarantees the machinery and equipment on this order, for a period as defined in the quotation from date of shipment, against defects in material and workmanship under the normal use and service for which it was recommended (except for parts that are typically replaced after normal usage, such as filters, liner plates, etc.). Conair's guarantee is limited to replacing, at our option, the part or parts determined by us to be defective after examination. The customer assumes the cost of transportation of the part or parts to and from the factory.

PERFORMANCE WARRANTY

Conair warrants that this equipment will perform at or above the ratings stated in specific quotations covering the equipment or as detailed in engineering specifications, provided the equipment is applied, installed, operated and maintained in the recommended manner as outlined in our quotation or specifications.

Should performance not meet warranted levels, Conair at its discretion will exercise one of the following options:

- Inspect the equipment and perform alterations or adjustments to satisfy performance claims. (Charges for such inspections and corrections will be waived unless failure to meet warranty is due to misapplication, improper installation, poor maintenance practices or improper operation.)
- Replace the original equipment with other Conair equipment that will meet original performance claims at no extra cost to the customer.
- Refund the invoiced cost to the customer. Credit is subject to prior notice by the customer at which time a Return Goods Authorization Number (RGA) will be issued by Conair's Service Department. Returned equipment must be well crated and in proper operating condition, including all parts. Returns must be prepaid.

Purchaser must notify Conair in writing of any claim and provide a customer receipt and other evidence that a claim is being made.

WARRANTY LIMITATIONS

Except for the Equipment Guarantee and Performance Warranty stated above, Conair disclaims all other warranties with respect to the equipment, express or implied, arising by operation of law, course of dealing, usage of trade or otherwise, including but not limited to the implied warranties of merchantability and fitness for a particular purpose.

The digital belt gap sensor uses a linear scale attached to both belts to measure the relative distance between the belts. The relative distance is shown in thousandths of an inch (.001). The sensor has five buttons:

USING THE DIGITAL BELT GAP SENSOR (OPTION)

- On/Off - Turns the device on and off.
- Mode - Press to choose the readout in decimals, fractions, or millimeters.
- + - Press to move up one engineering unit.
- 0 - Press to zero the reading. Because all measurements are relative, the sensor can be set to zero at any time by pressing this button.
- - - press to move down one engineering unit.

Readings displays on the digital display.

For more information, refer to the belt gap sensor manual.

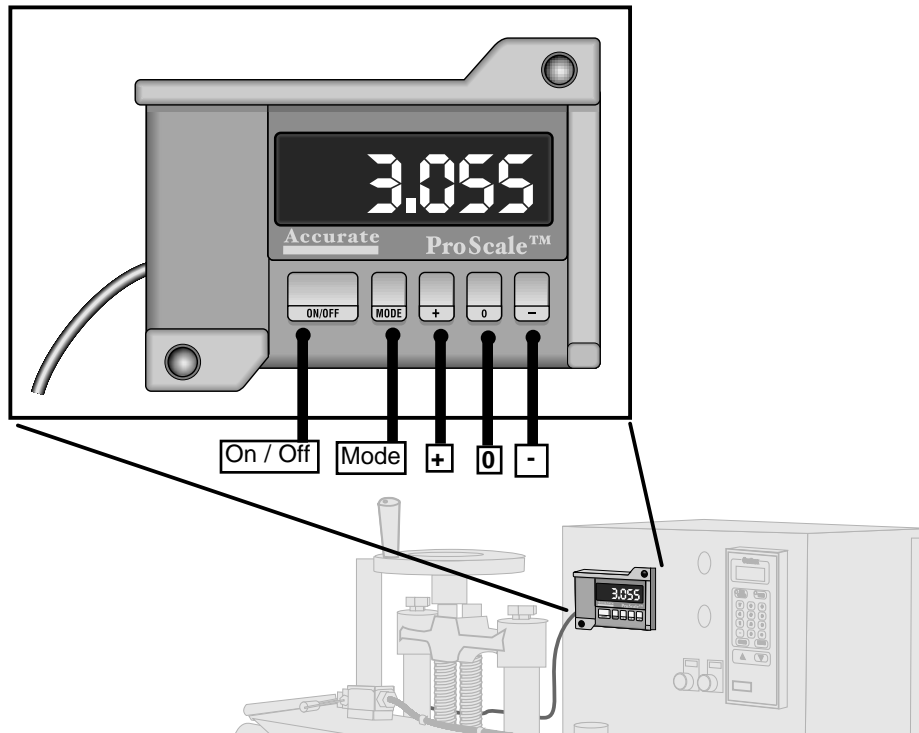

ADJUSTING THE PNEUMATIC UPPER BELT ACTUATOR (OPTION)

You can adjust the speed of the air cylinder assembly that operates the upper belt boom assembly. Choose which airline you want opened. Move the handle (shown) to direct the air through the tubing:

- When the handle is in the upper position, air is open to the top air line and closed to the bottom airline.
- Move the handle to the down position and the air is closed to the top air line and open to the bottom air line.

Open up the back of the puller and set the speed of the air cylinder assembly by adjusting the flow control valves on the cylinder.

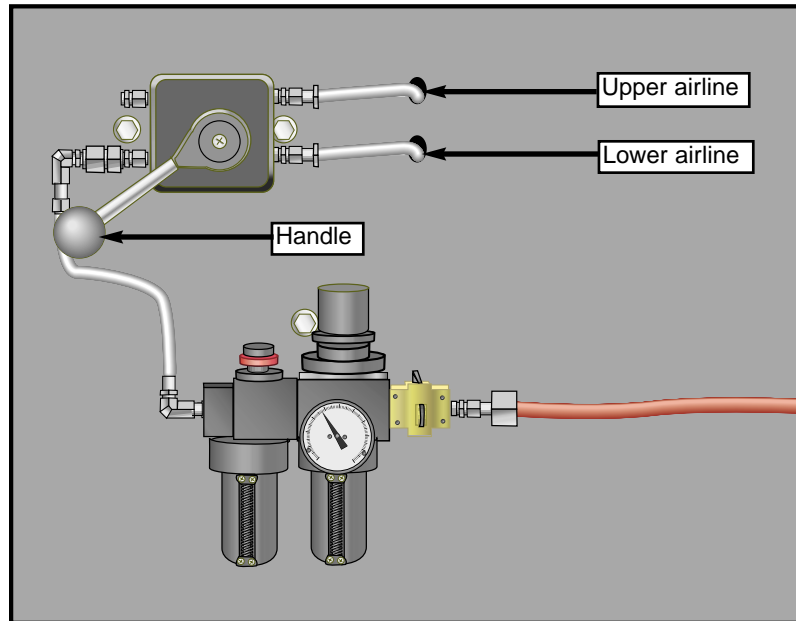

When considering puller performance, an important concern is the type of puller belt. To select the proper belt material, you must consider the extrudate's tendency to deform under pressure. For example, thin wall profiles and tubing are prone to deformation, so you need lower pressures and longer traction lengths to deliver the required pulling force without deformation and slippage.

CHOOSING BELT MATERIALS

Various belt materials are available: natural rubber, neoprene and urethane.

To choose the proper belt for your application, refer to the table or consult your Conair representative.

CONAIR BELTS

Model 3-20

Belt Type:

Poly V Belts (490J32) and Pulleys:

Available coverings: Pick one (consult factory for application)

- * 40 durometer natural rubber (Tan) #3511-30008
- * 55 durometer natural rubber (Green) #3511-30112
- * 70 durometer natural rubber (Red) #17304708
- * 60 durometer white Nitrile (FDA) #17304702

Flat Belts and Pulleys:

Available coverings: Pick one (consult factory for application)

- * 40 durometer natural rubber (Tan) #17303901
- * 70 durometer Urethane (Green) #17303903

CONAIR BELTS

CONTINUED

Model 4-26

Belt Type: **Poly V Belts (655L20) and Pulleys:**

Available coverings: Pick one (consult factory for application)

- * 40 durometer natural rubber (Tan) #3511-30016
- * 60 durometer Nitrile (White FDA) #17304606
- * 55 durometer natural rubber (Green) #3511-3008
- * 70 durometer natural rubber (Red) #3511-30032

Flat Belts and Pulleys:

Available coverings: Pick one (consult factory for application)

- * 40 durometer natural rubber (Tan) #17303904
- * 55 durometer natural rubber (Green) #17303908
- * 60 durometer Nitrile (White) #17303907
- * 70 durometer Urethane (Green) #17303906

Hi-Speed Belt for speeds above 472 ft./min.

- * 55 durometer natural rubber (3mm Green) #1730390801
-

Model 6-39

Belt Type: **Poly V Belts (915L32) and Pulleys:**

Available coverings: Pick one (consult factory for application)

- * 40 durometer natural rubber (Tan) #3511-30024
 - * 50 durometer natural rubber (Brown) #3511-30096
 - * 70 durometer natural rubber (Red) #3511-30048
-