

USER GUIDE  
UGE052-0917

# BP Series Belt Pullers

BP 6-50, BP 8-50 and BP 12-50



Please record your equipment's model and serial number(s) and the date you received it in the spaces provided.

It's a good idea to record the model and serial number(s) of your equipment and the date you received it in the User Guide. Our service department uses this information, along with the manual number, to provide help for the specific equipment you installed.

Please keep this User Guide and all manuals, engineering prints, and parts lists together for documentation of your equipment.

Date:

---

Manual Number: UGE052-0917

---

Serial Number(s):

---

Model Number(s):

---

**DISCLAIMER:** Conair shall not be liable for errors contained in this User Guide or for incidental, consequential damages in connection with the furnishing, performance or use of this information. Conair makes no warranty of any kind with regard to this information, including, but not limited to, the implied warranties of merchantability and fitness for a particular purpose.

# Table of Contents

## 1 - 1 Introduction

Purpose of the User Guide .....	1-2
How the Guide is Organized.....	1-2
Your Responsibility as a User.....	1-2
ATTENTION: Read This So No One Gets Hurt .....	1-3
How to Use the Lockout Device .....	1-4

## 2 - 1 Description

What is the BP Series Belt Puller? .....	2-2
Typical Applications.....	2-2
How It Works .....	2-3
BP Series Belt Puller Features .....	2-4
Specifications:.....	2-5

## 3 - 1 Installation

Unpacking the Boxes.....	3-2
Preparing for Installation .....	3-3
Installing the Puller.....	3-4
Connecting the Main Power Source .....	3-5
Adjusting Belt Tension .....	3-6
Setting the Belt Gap .....	3-7
Testing the Installation.....	3-8

## 4 - 1 Operation

Start-Up Preparations.....	4-2
Starting the BP Series Belt Puller.....	4-2
Operations .....	4-3
Stopping the BP Series Belt Puller .....	4-4
Shutting Down .....	4-4
How to Navigate the Control Screens.....	4-5
The BP Series Belt Puller Main Operating Screen.....	4-7

The BP Series Belt Puller Home Screen .....	4-9
The BP Series Belt Puller Control Flow Charts.....	4-10
Control Function Descriptions.....	4-18

## 5 - 1 Maintenance

Preventative Maintenance Schedule .....	5-2
Replacing the Belts .....	5-5
Lubricating Shafts and Fittings .....	5-6
Checking Electrical Connections.....	5-7

## 6 - 1 Troubleshooting

Before Beginning.....	6-2
A Few Words of Caution.....	6-2
Identifying the Cause of a Problem .....	6-3
Operation Problems.....	6-4
Product Quality Problems .....	6-5

## A Appendix

Customer Service Information .....	A-1
Warranty Information.....	A-2

## B Appendix

Using the Digital Belt Gap Sensor .....	B-1
Adjusting the Pneumatic Upper Belt Actuator .....	B-2

# Description

---

What is the BP Series Belt Puller? ..... 2-2

Typical Applications ..... 2-2

How It Works ..... 2-3

BP Series Belt Puller Features..... 2-4

Specifications ..... 2-5

# What is the BP Series Belt Puller?

The Conair BP Series Belt Pullers are designed to consistently pull medium to large-sized extruded products through sizing and/or cooling tanks.

The standard chain drive system is suitable for applications requiring relatively high pulling force. The hardened chain drive gears protected with high temperature grease make the chain drive shaft pullers a good choice for high torque, low speed applications.

## Typical Applications

Conair BP Series Belt Pullers can pull extrudable plastics and elastomers both on and off line. These units can pull tubes and profiles up to about 4 inches in diameter through a vacuum sizing tool. Larger sizes may be accommodated for free extrusion processes having little or no drag against a sizing tool.

The belt pullers are limited by the traction length (the length over which the extrusion is in contact with the puller belts), which is fixed for a particular model.

Conair BP Belt Pullers are available in three sizes:

Model	Belt Width	Traction Length *
BP 6-50	6 in.	50 in.
BP 8-50	8 in.	50 in.
BP 12-50	12 in.	50 in.

\*The approximate length the belts are in contact with each other.



The outer surface of the puller belt material will affect puller performance.

Softer (low durometer) materials provide good ‘grab’, but will wear more quickly, and may tear if the belt jams. Harder materials last longer, but may not grab the extrusion properly.

Poly-V belts are standard on the BP Belt Pullers. Other materials are available.

Contact Conair Parts: (800) 458 1960  
From outside of the United States, call:  
(814) 437 6861.

Contact Conair for specific belt material recommendations for your product.

# How It Works

## (The Optional Footage Counter)

Two opposing belts pull the extrusion through the line based on the speed set at the puller's speed reference potentiometer. The optional footage counter displays linear speed (ft/min) or motor rpm in English or metric units, depending on customer preference.

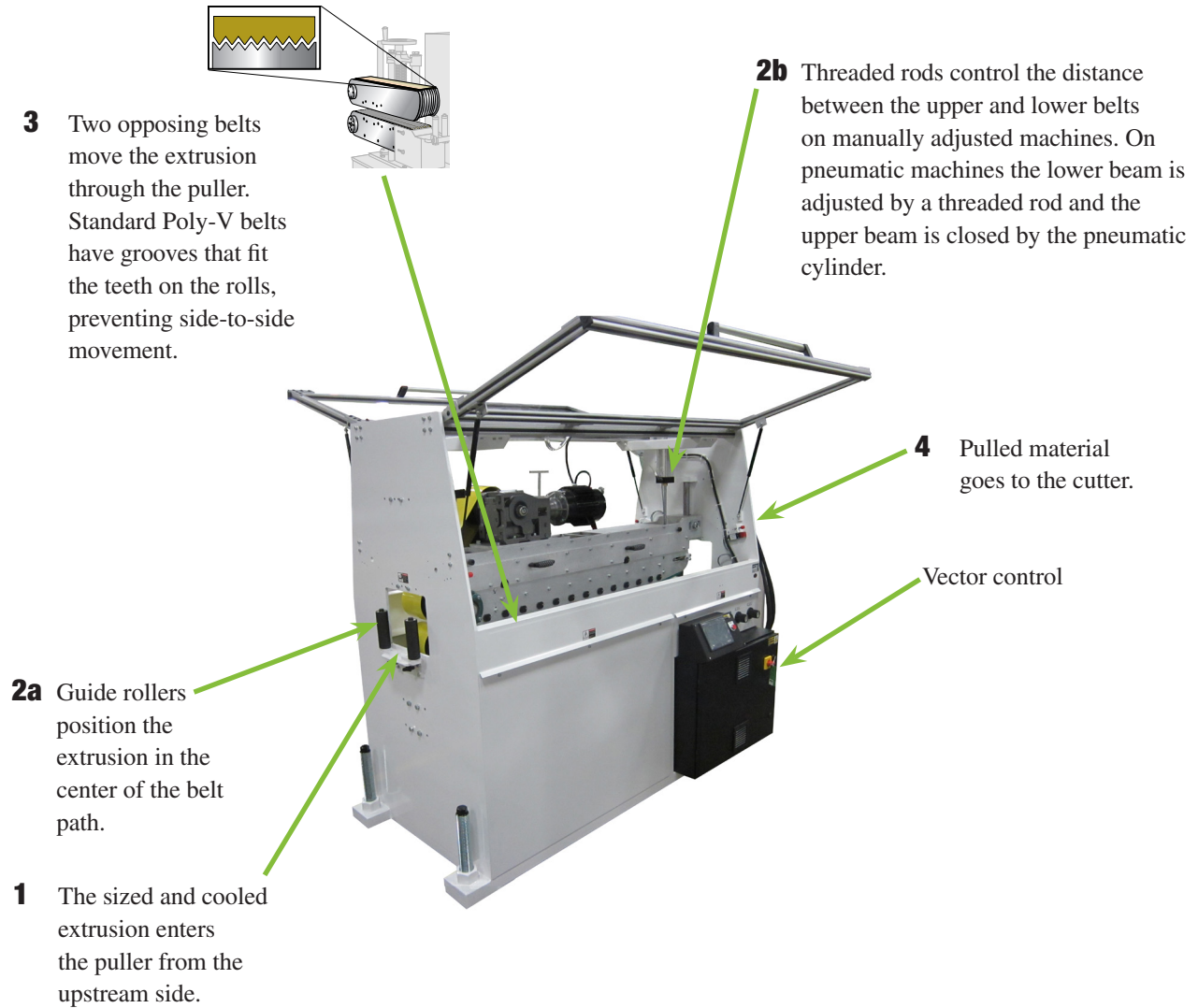

# BP Series Belt Puller Features

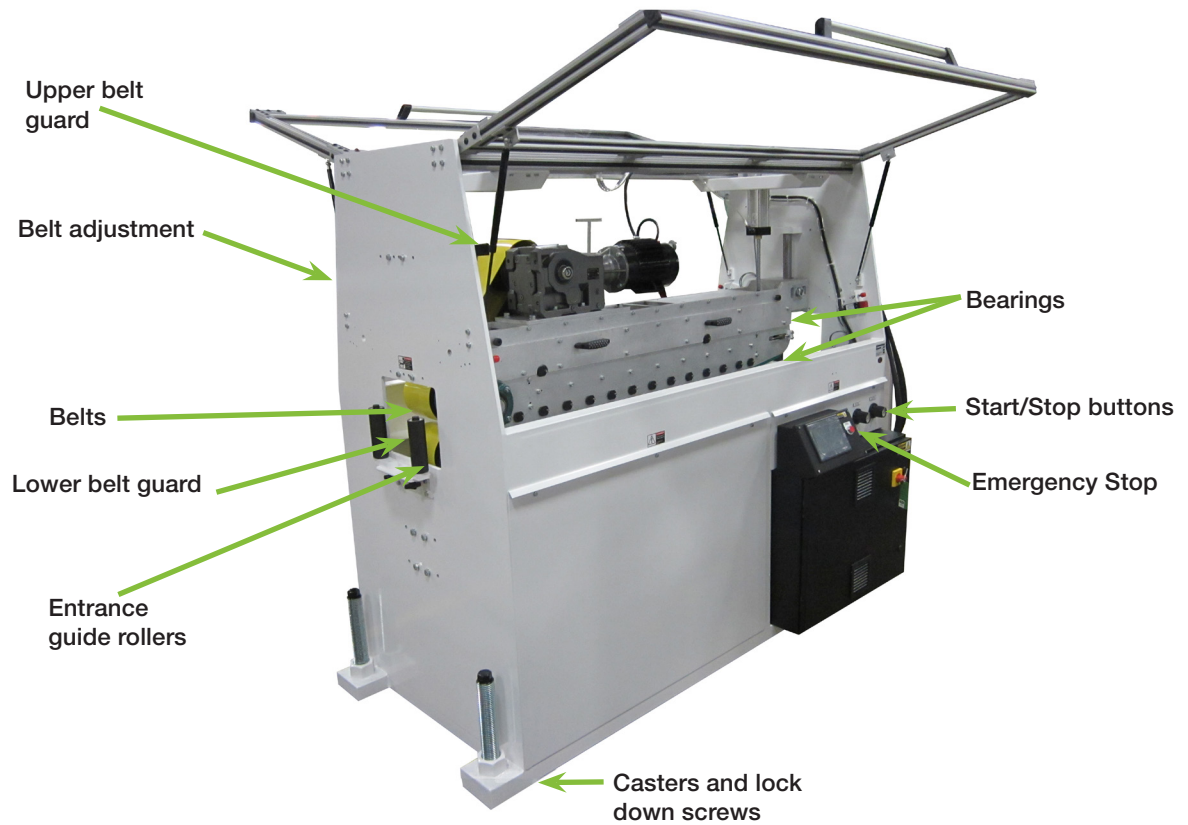

# Specifications: Belt Pullers

## BP Series Belt Pullers

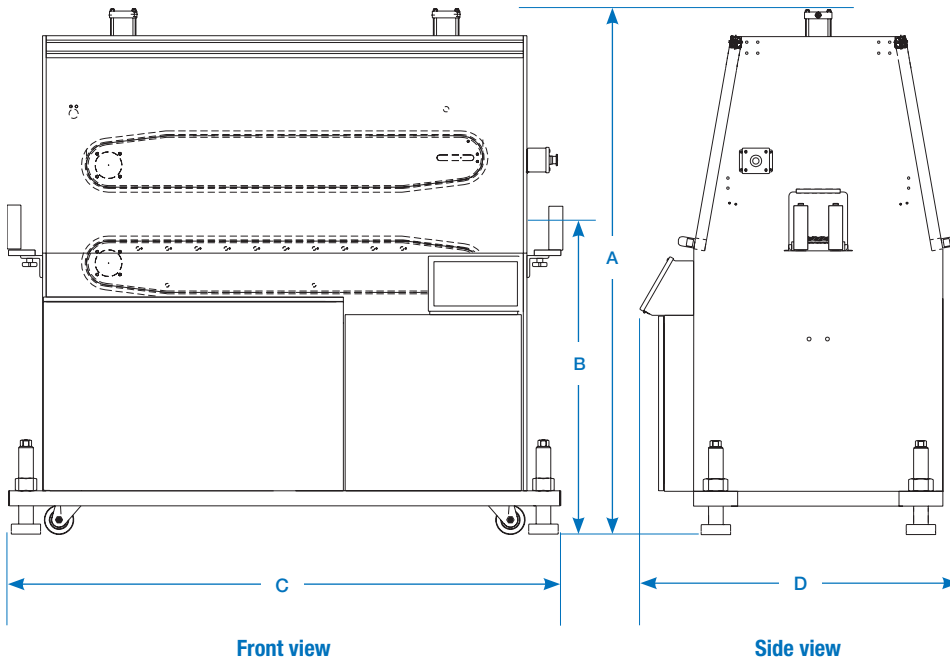

## Control

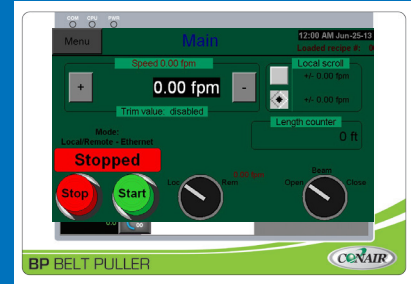

The BP Puller features a full-color touchscreen control. With graphic icons, intuitive operation is simple! Switch operation modes, make adjustments, save recipes, and create unique user privileges all from a touchscreen control that allows for easy communication to other devices. All Conair controls are designed with the same style icon/button operation, making learning a new piece of equipment easy and comfortable.

Description  
2

Models	BP 6-50	BP 8-50	BP 12-50
<b>Performance characteristics</b>			
Belt width inches {mm}	6 {152}	8 {203}	12 {304}
Belt contact length inches {mm}	50 {1270}		
Maximum feed opening inches {mm}	6 {152}	8 {203}	12 {304}
Drive motor	2 Hp		3 Hp
Drive types available	Open loop vector; Servo		
Belt type	Poly-V belt with 1/2 inch 40A duro pure gum rubber (60A duro red EPDM belts are optional)		
<b>Belt speeds</b>			
Drive type	Fixed Reducer (Dual speed transmission available as an option)		
Available speed ranges feet/min.	Consult Conair		
<b>Dimensions inches {mm}</b>			
A - Height	76 {1930}		
B - Height to centerline	42.5 {1080}		
C - Overall length	66 {1676}		54 {1372}
D - Overall width	32 {813}		37 {940}
<b>Weight lb {kg}</b>			
Installed	1910 {866}	1810 {821}	1710 {776}
Shipping	2210 {1002}	2110 {957}	2010 {912}
<b>Voltage Full load amps * †</b>			
230V/1 phase/60 Hz	24		
460V/1 phase/60 Hz	11		
575V/1 phase/60 Hz	9		

### Specification Notes

\* 3-phase power available on AC inverter, flux vector and servo equipped models.

† FLA data for reference purposes only. Does not include any options or accessories on equipment. For full FLA detail for power circuit design of specific machines and systems, refer to the electrical diagrams the equipment order and the nameplate applied to the machine.

Specifications may change without notice. Consult with a Conair representative for the most current information.



# Installation

---

Unpacking the Boxes .....	3-2
Preparing for Installation .....	3-3
Installing the Puller .....	3-4
Connecting the Main Power Source .....	3-5
Adjusting Belt Tension .....	3-6
Setting the Belt Gap .....	3-7
Testing the Installation .....	3-8

# Unpacking the Boxes



## **WARNING: Lifting Hazard**

To avoid personal injury or damage to the puller, lift the puller using a forklift or hoist with straps that have been positioned at the puller's center of gravity.



- 1 Carefully uncrate the puller and its components.** The BP Series Belt Puller comes fully assembled in a single crate.
- 2 Remove all packing material, protective paper, tape, and plastic.** Compare contents to the shipping papers to ensure that you have all the parts.
- 3 Carefully inspect all components** to make sure no damage occurred during shipping. Check all wire terminal connections, bolts, and any other electrical connections, which may have come loose during shipping.
- 4 Record serial numbers and specifications** in the blanks provided on the back of the User Guide's title page. This information will be helpful if you ever need service or parts.
- 5 You are now ready to begin installation.** Complete the preparation steps on the next page.

## Preparing for Installation

 **WARNING: Improper installation, operation, or servicing may result in equipment damage or personal injury.**

 This equipment should be installed, adjusted, and serviced by qualified technical personnel who are familiar with the construction, operation, and potential hazards of this type of machine.

All wiring, disconnects, and fuses should be installed by qualified electrical technicians in accordance with electrical codes in your region. Always maintain a safe ground. Do not operate the equipment at power levels other than what is specified on the machine serial tag and data plate.

You will install the puller on the extrusion line, downstream of the extruder and any calibration/sizing equipment.

### 1 Make sure the installation area provides:

- A grounded power source** supplying the correct current and voltage. Check the serial tag for the correct amps, voltage, phase and cycles. All wiring should be completed by qualified personnel and should comply with your region's electrical codes.
- Minimum clearance for safe operation and maintenance.**  
Allow at least 12 to 24 inches {305 to 610 mm} between the downstream end of sizing or cooling tanks and the upstream end of the puller to roll the tank away from the extruder for maintenance. Allow at least 36 inches {91.44 mm} clearance in front and back of the puller for maintenance access to electrical and mechanical systems.

### 2 Determine the correct position for the puller.

The puller will be positioned downstream of the extruder and any sizing equipment, and upstream of the cutter. You must consider optional equipment and product type to determine the best spacing between the equipment.

- **For flexible products**, the puller should be as close as possible to the cutter.
- **For rigid products**, leave enough space between the puller and the cutter to allow the product to flex during the cutting cycle. It may be necessary to allow 6-8 feet {1.83 to 2.44 m} between the puller and cutter.
- **When operating with an optional laser gauge or diameter gauge**, allow 1 to 2 feet {.30 to .61 m} between the laser gauge and the puller.



distance between puller and saw depends on product type

12 to 24 inches between puller and laser gauge or sizing equipment

### Tools Required:

- 16- or 18-inch adjustable wrench
- Set of Allen wrenches

## Installing the Puller



### WARNING: Lifting Hazard

To avoid personal injury or damage to the puller, lift the puller using a forklift or hoist with straps that have been positioned at the puller's center of gravity.

- 1 Move the puller into position.** Place the belt puller downstream of the extruder and upstream of the cutter in the position determined during preparation.



- 2 Measure the center height** of the extruded product as it exits the extrusion line. Make sure all equipment on the extrusion line is aligned to this height. Use a plumb line or laser to check for a straight line from the extrusion die through each line component.

- 3 Align the puller with the centerline height of the extrusion line.** Adjust the puller's floor lock/caster assembly to the center height of the extrusion line using a 16- or 18-inch adjustable wrench. Turn the floor locks until the puller reaches the center height of the extrusion line.

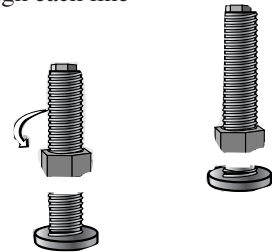

**IMPORTANT: Never operate the puller on casters.** Always use the leveling jacks to support the puller. Once the correct height is reached, adjust the pad assembly to remove the weight from the casters.

- 4 Adjust the belt puller entrance guide rollers** to insure consistent guidance of the product along the centerline.



## Connecting the Main Power Source



### **WARNING: Electrical Hazard**

Before performing maintenance or repairs on this product, disconnect and lock out electrical power sources to prevent injury from unexpected energization or start-up. A lockable device has been provided to isolate this product from potentially hazardous electricity.



### **WARNING: Improper installation, operation, or servicing may result in equipment damage or personal injury.**

This equipment should be installed, adjusted, and serviced by qualified technical personnel who are familiar with the construction, operation, and potential hazards of this type of machine.

All wiring, disconnects, and fuses should be installed by qualified electrical technicians in accordance with electrical codes in your region. Always maintain a safe ground. Do not operate the equipment at power levels other than what is specified on the machine serial tag and data plate.

#### **1 Open the combination puller's electrical enclosure.**

Turn the disconnect dial on the door to the OFF or O position and open the door.



#### **2 Insert the main power wire through the knockout in the side of the enclosure. Secure the wire with a rubber compression fitting or strain relief.**

#### **3 Connect the power wires to the three terminals indicated on the wiring diagram that came with your machine.**

#### **4 Check every terminal screw to make sure wires are secure. Gently tug each wire. If a wire is loose, use a screwdriver to tighten the terminal.**

#### **5 Connect the ground wire to either grounding point shown in the wiring diagram.**

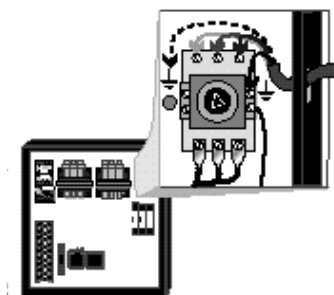

**IMPORTANT:** Always refer to the wiring diagrams that came with your belt puller before making electrical connections. The diagrams show the minimum size main power cable required for your puller, and the most accurate electrical component information.

# Adjusting Belt Tension

- 1 Turn the main power disconnect to the Off position**
- 2 Remove the belt guards.**
- 3 Check belt tension.** Belts should be just tight enough to prevent slipping, and the gap between the upper and lower belts should be even across the width of the belt.

 **NOTE:** Loose belts cause belt and product to slip; over-tightened belts result in distorted product and can lead to premature bearing failure.

belt  
guards



- 4 Adjust belt tension, if necessary.** Adjust tension by turning the threaded tension rods. Keep tension on front and back edges, top and bottom belts as even as possible. Use a machinist's ruler to measure the distance between the idler shaft and the steel block that the bolts are against. Make sure the left and right side bolts are the same.

**5 Fine tune tension:**

- **Lower the belts** to a gap of about 1/8 inch {3 mm}.  
(See Setting the Belt Gap)
- **Check the appearance of the belt gap.** From the upstream end, look down the length of the belts. The shape of the gap should not be concave (over-tightened) or convex (too loose). Adjust the tension until the gap is even and measures 1/8 inch.
- **Check tension and re-adjust as necessary.**

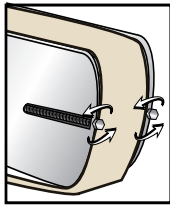

# Setting the Belt Gap

The belt gap should be set to the dimensions of the extruded product, being careful not to make the gap so small that the pressure causes distortion in the product.

## For the BP Pullers

Each belt boom assembly is moved separately. A single handle is used for both threaded rods. To move the handle from one rod to the other, lift it and place it on the other shaft. You may have to rotate it slightly to engage the keyway with the key on the shaft.

- 1** Pneumatic
- 2** Fixed in place

 **NOTE:** See the Appendix for instructions on using the optional Pneumatic Upper Belt Actuator to position the upper belt.

# Testing the Installation



## **DANGER: Pinch Hazard**

Never remove or disable safety devices to sustain production. Operating without these devices could lead to hazardous conditions that can cause severe injury. Take all necessary precautions when working around moving parts to prevent body parts and clothing from being pulled into the machine.

- 1 Make sure all components** are installed according to assembly drawings. Check all bolts on the puller for tightness.
- 2 Check that puller is firmly anchored** into position with the floor locks.
- 3 Check that all wiring conforms to electrical codes**, and all wiring covers are in place.
- 4 Turn on the main disconnect.** Plug in the main power cord and turn on the main disconnect.
- 5 Check that the E-Stop button is in the out, extended position.**
- 6 Press Start button.** The belts should begin to rotate.

If the puller is not working properly at any time, turn it off immediately and *refer to the Troubleshooting section of this User Guide*.

If you do not encounter any problems, proceed to the Operation section.

# Operation

---

Start-Up Preparations .....	4-2
Starting the BP Series Belt Puller .....	4-2
Operations .....	4-3
Stopping the BP Series Belt Puller .....	4-4
Shutting Down .....	4-4
How to Navigate the Control Screens.....	4-5
The BP Series Belt Puller	
Main Operating Screen .....	4-7
The BP Series Belt Puller	
Home Menu Screen .....	4-9
The BP Series Belt Puller	
Control Flow Charts .....	4-10
Control Function Descriptions .....	4-18

## Start-Up Preparations



**WARNING: Improper installation, operation, or servicing may result in equipment damage or personal injury.**

This equipment should be installed, adjusted, and serviced by qualified technical personnel who are familiar with the construction, operation, and potential hazards of this type of machine.

All wiring, disconnects, and fuses should be installed by qualified electrical technicians in accordance with electrical codes in your region. Always maintain a safe ground. Do not operate the equipment at power levels other than what is specified on the machine serial tag and data plate.

- 1 Locate the BP Series Belt Puller on the extrusion line** with the floor support pads adjusted to the product centerline.



**NOTE:** Loose belts cause belt and product to slip; over-tightened belts result in distorted product and can lead to premature bearing failure.

- 2 Be sure power supply matches** specified belt puller power before connecting. If unsure, please do not hesitate to call the factory.
- 3 Adjust the belt puller** entrance guide rolls to insure consistent product guidance.
- 4 Adjust the belt opening to allow consistent traction to the product without deformation.**

## Starting the BP Series Belt Puller



**DANGER: Moving parts; pinch hazard**



Safety devices have been installed on this machine to prevent injury that could result from clothing or the operator becoming caught in moving traction belts. Never remove or disable safety devices to sustain production. Operating without these devices could lead to hazardous conditions that can cause severe injury.

- Walk-through style belt guards protect from injury, but also allow side entry for ease of operation. Upper and lower belt guards independently protect the operator from being caught in the belts or associated driven sheaves
- The emergency stop (E-stop) button is located on the upstream side of the control box. When pressed, it works in parallel with the guard switch to disconnect power to the belt drive. The E-stop must be physically pulled up to reset the switch and start the puller again.

# Starting the BP Series Belt Puller

(continued)

Before you start daily operation of the BP Series Belt Puller, you should:

- Inspect the puller belts.
- Check puller alignment with the extrusion line.
- Assure the floor locks are properly engaged.
- Thread the extrudate through the sizing equipment, puller, and any other devices on the extrusion line puller.

See the *Maintenance Section of this User Guide* for detailed information on daily maintenance procedures.



This is the first screen to appear when turning the power on to the BP Series Belt Puller. After power is turned on, the HMI panel will initialize. After it has initialized, the “Splash” screen will appear and the panel will establish communications with the puller controller. This screen shows Conair contact information. Use the Service/Parts number to contact the Conair resource line.

To start the BP Series Belt Puller:

- 1** Wait until the human machine interface (HMI) panel has initialized and is displaying the Main Menu Screen.
- 2** Check that the emergency stop buttons are functioning correctly.
- 3** Reset the emergency stop circuit if necessary.

## Operations

- 1 Power up the BP Series Belt Puller.** After power up, feed extrudate into puller.
- 2 Open the gap** between the puller belts to the desired gap for the product to be pulled.
- 3 Adjust belt speed** to attain proper sizing.

Contact Conair Customer Service  
1 800 458 1960.  
From outside of the United States,  
call: 814 437 6861

# Stopping the BP Series Belt Puller



## **WARNING: Safe Stopping**

Do not use any part of the guard circuit or the rotary disconnect to stop the belt puller. Use the recommended procedure to assure a safe stopping.

- 1 Remove extrudate from the puller.**
- 2 Press the red Stop button.**
- 3 Turn rotary disconnect to OFF.**

## Shutting Down

To shut down the puller, perform the stopping procedure listed above. No additional steps are necessary if the puller is shut down for short period of time.

If the puller is shut down for an extended period of time, belts can acquire “set.” If this occurs, let the puller run for 20-30 minutes before use. This should remove any “set” from the belts.

# How to Navigate the Control Screens

Navigate through the BP Series Belt Puller Control Screens by touching any black text which opens a screen or pop up window. The colored text is not selectable and represents current data being displayed.

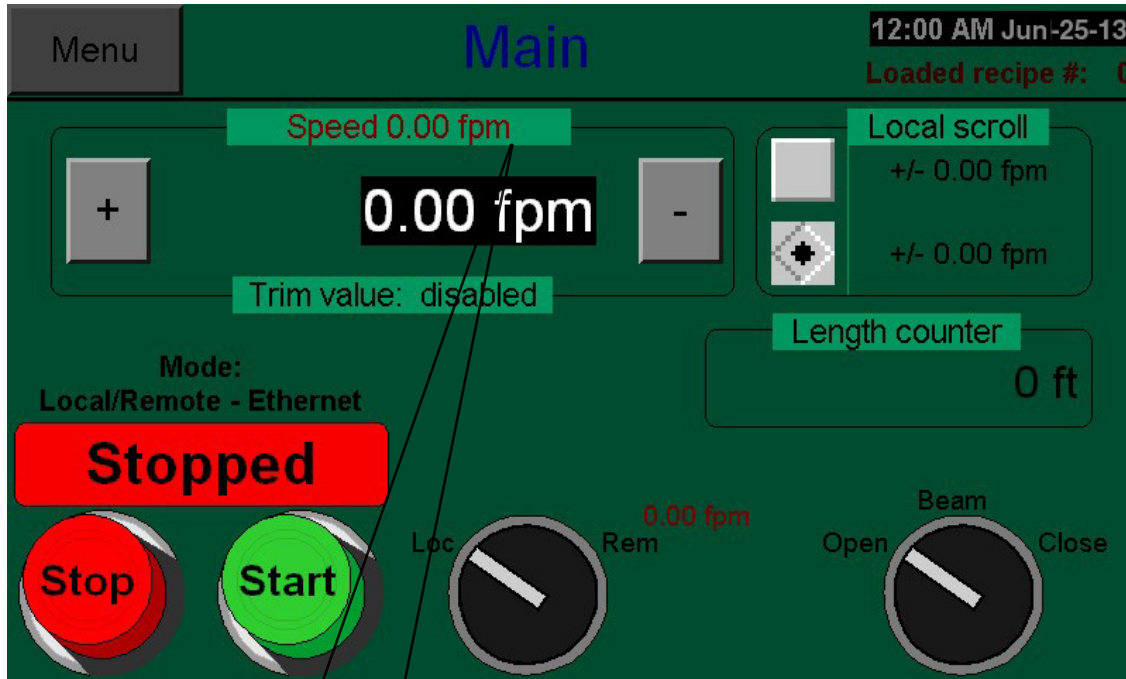

Example of Pop Up Number Pad

# How to Navigate the Control Screens (continued)

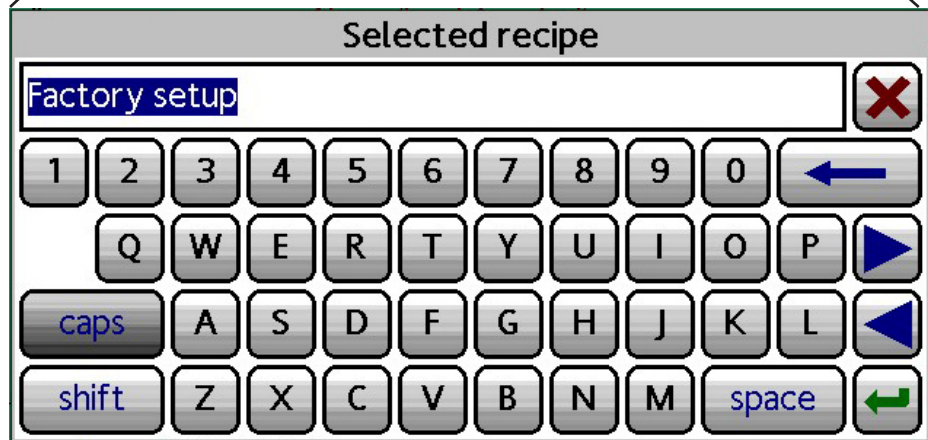
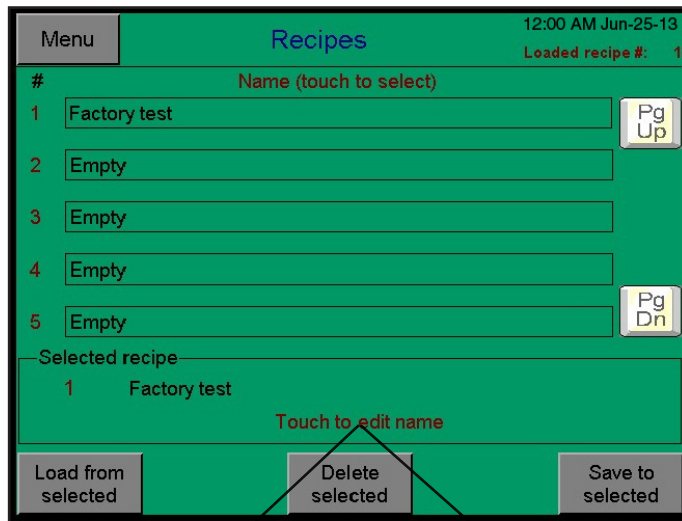

Example of Pop Up Keypad

# The BP Series Belt Puller Main Operating Screen

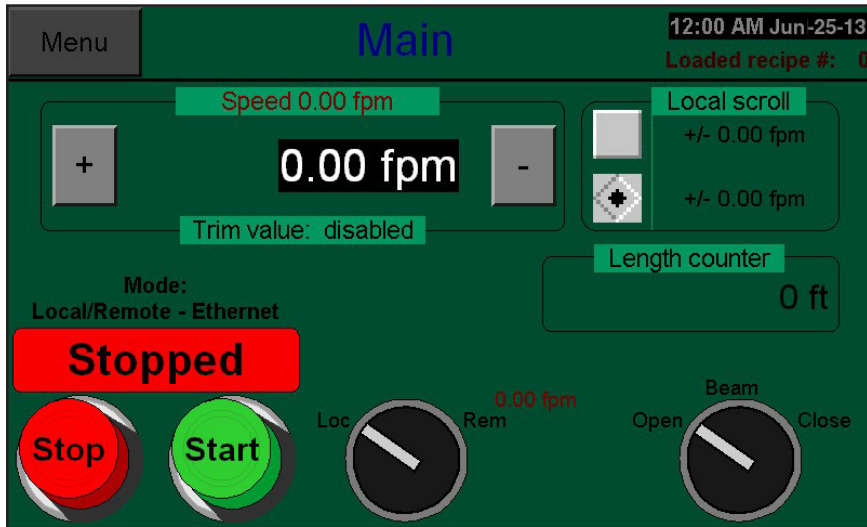

Shortly after power up, the Splash screen is replaced by the Main Operating screen. This is the screen that will be showing most of the time during operation.

- Menu Square** Pushing either of the menu squares will take you to the Menu screen.
- Fault Square** If the machine is in a fault condition, the “Faulted” screen will appear. Push this square and it will take you to the Fault Screen.



- Mode** Push this square and it will take you to the Mode Screen for the puller. Modes can only be changed when the puller is off.
- Speed:** Pushing the number area of the speed section will bring up a key pad. The desired speed can be entered via the key pad. Pushing the “+” or “-“ will change the speed of the puller up or down the amount designated by the Local Scroll amount.

(continued)

# The BP Series Belt Puller Main Operating Screen *(continued)*

- Local Scroll** This is where the amount of change that occurs with a single push of the “+” or “-“ buttons that are on either side of the speed display can be set. The local scroll screen will come up if this area is pushed. Push the dot on the side of the large scroll or small scroll for which you would like to use. A single push of either the “+” or “-“ button will change the puller speed by the increment entered in the scroll box.
- Start/Stop:** This button will start or stop the puller.
- Local/Remote:** This switch can be switched to select whether the controls for the puller are via the HMI (local) or from an external/remote source. The puller mode selection box will come up when this is selected.
- Length Counter:** Pushing this square will bring up the Length counter screen. The length counter can be turned on/off or reset there.
- Open/Close Beam:** Raises or lowers the top beam for use.

# The BP Series Belt Puller Menu Screen

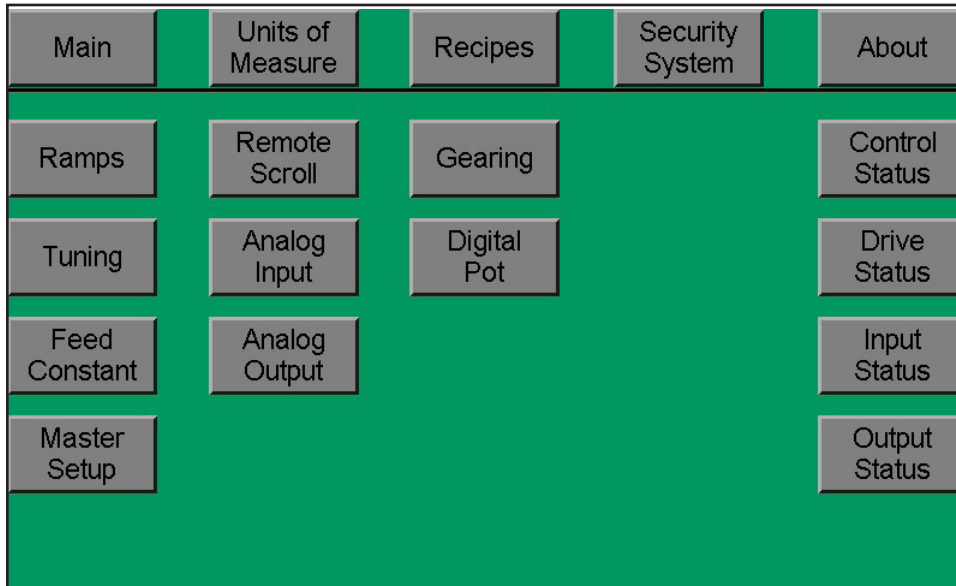

The Menu screen provides access to all other display screens. Press the appropriate button to change screens. When a machine fault occurs, a machine fault indicator/button will appear in the upper right corner of the display screen. Press this button to display the error message pop-up box.

- Main:** This is the general Menu screen. This screen is pulled up when the Menu button is pushed at the lower left corner of the HMI or on the top left corner of the Main control screen. This gives you access to most of the HMI screens.
- Units of Measure:** This screen is where the units can be selected between standard units and metric units. Touch the box next to the units desired.
- Recipes:** Individual recipes can be saved on this screen. Up to 99 different recipes can be saved. A saved recipe will collect all set points of the current conditions of the puller when it is saved. Recipes can be saved at any time. Recipes can only be loaded when the machine is in the stopped condition. You will see the following screens when a recipe is saved, a recipe is loaded, or a recipe is deleted.
- System Security:** This screen allows you to create a password for a User and to “LogOn” or “LogOff” of the system. The “Set Pass” button takes you to the Security Manager screen where the password is assigned. Once the password has been assigned, the “LogOn” and “LogOff” buttons can be used to access the system.
- About:** This screen displays the version information of the Crimson programming software used to create the HMI screens. It also displays Conair’s contact information. Touchscreen calibration is accessed from this screen.

# The BP Series Belt Puller Control Flow Charts

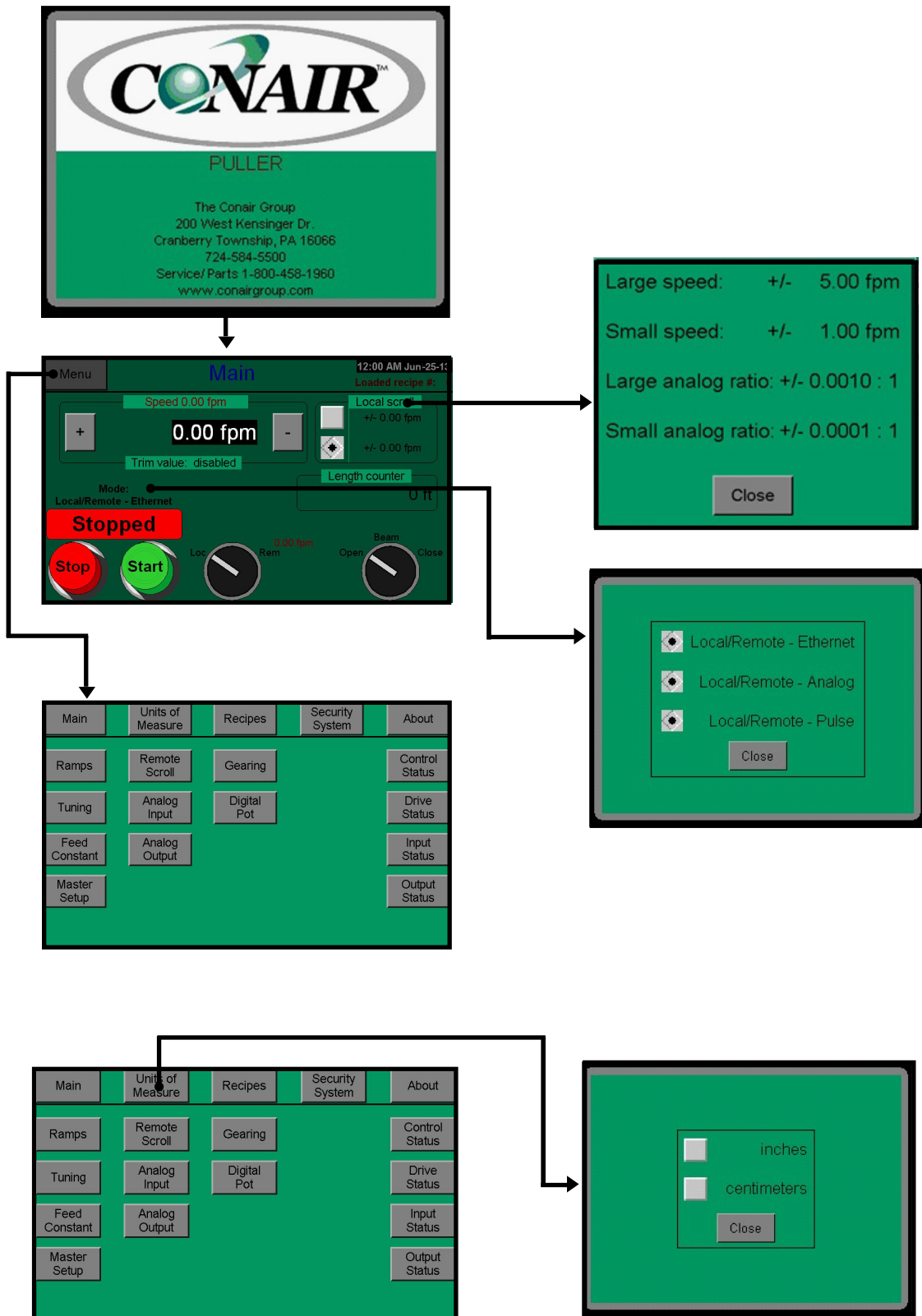

# The BP Series Belt Puller Flow Charts (continued)

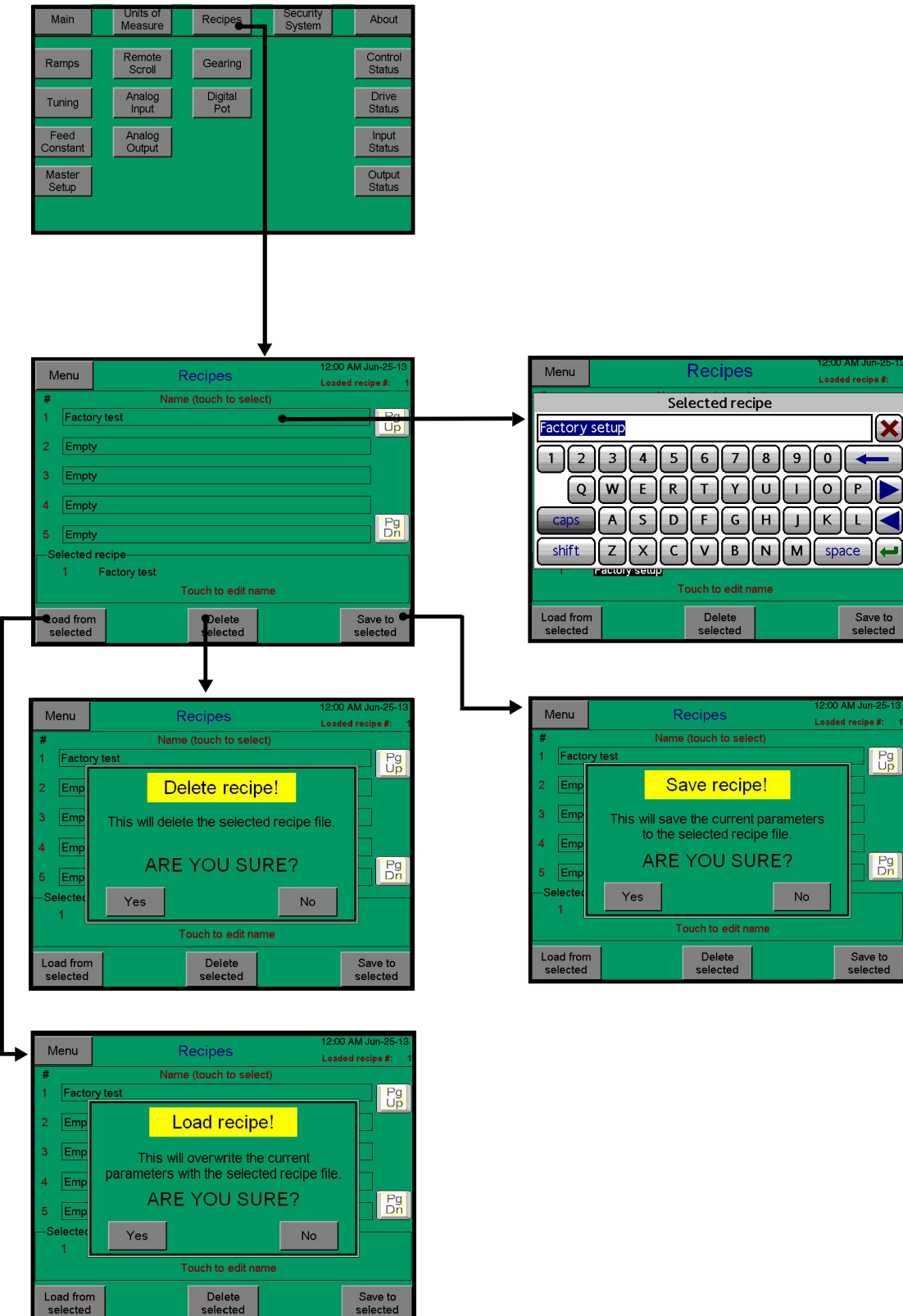

(continued)

# The BP Series Belt Puller Flow Charts

(continued)

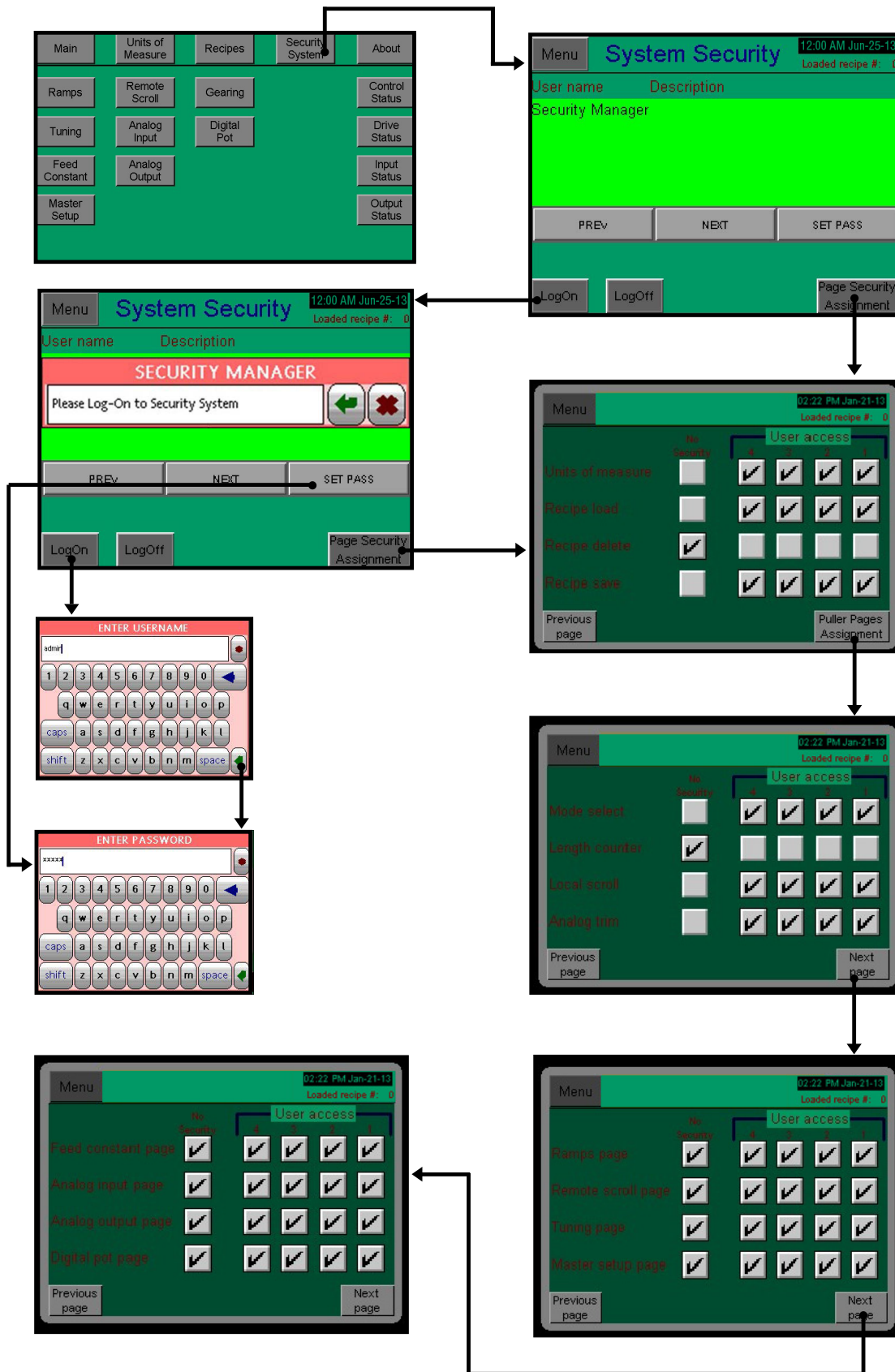

# The BP Series Belt Puller Flow Charts

(continued)

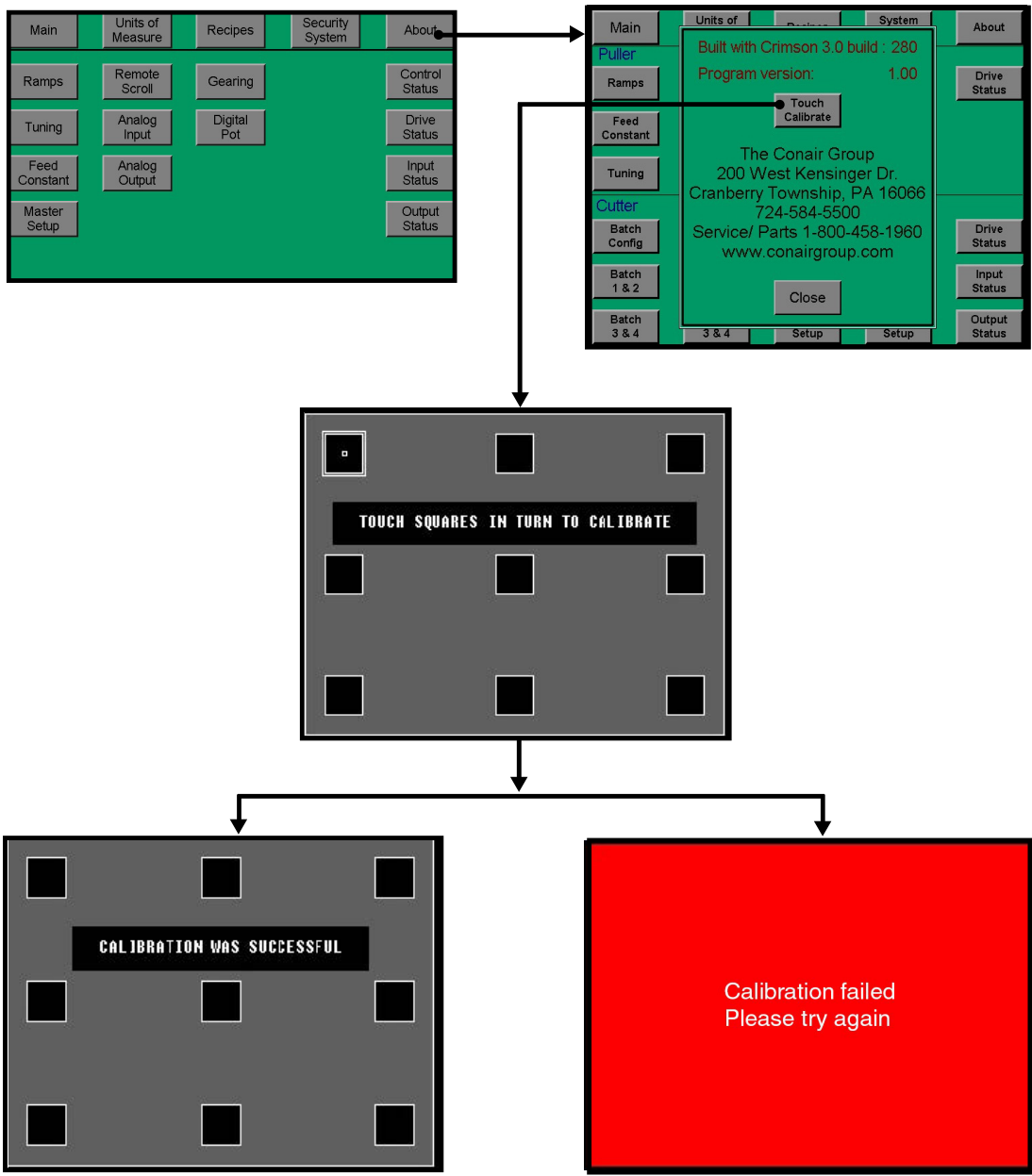

# The BP Series Belt Puller Flow Charts

(continued)

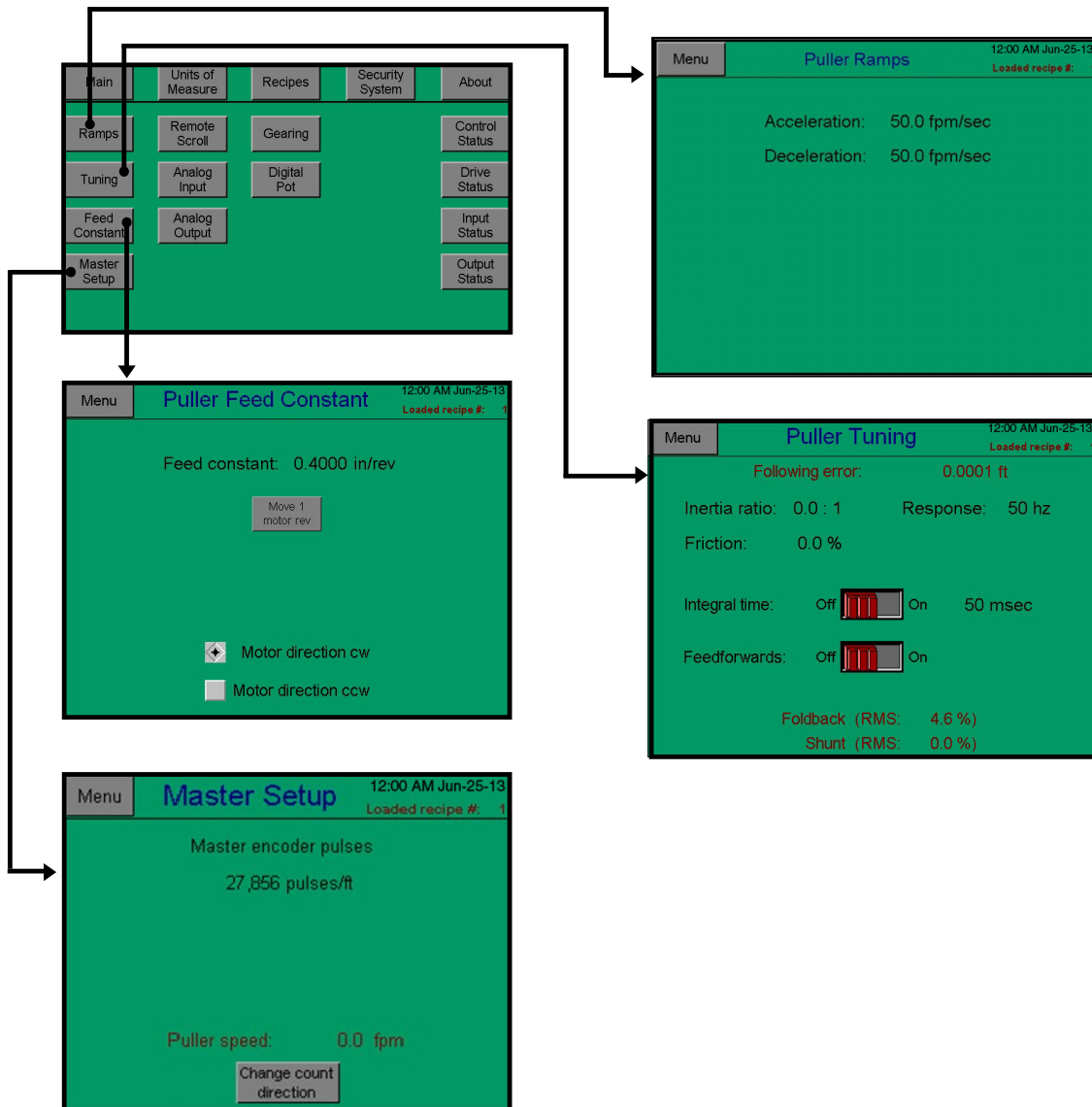

# The BP Series Belt Puller Flow Charts (continued)

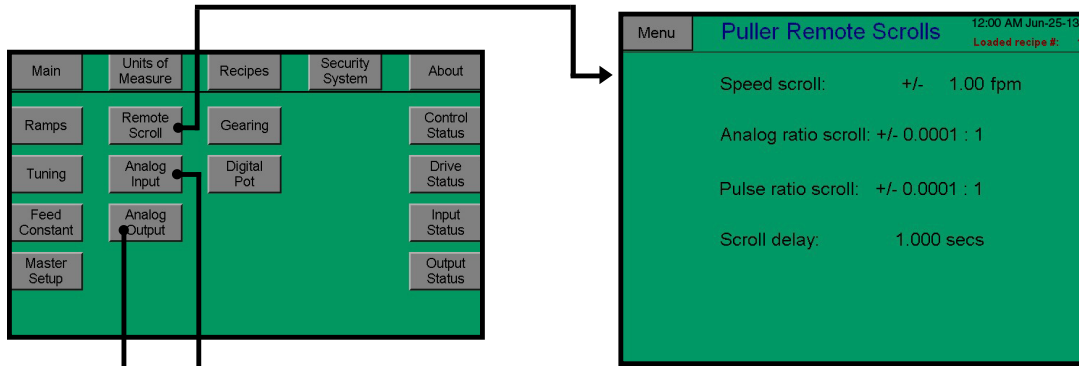

Menu **Puller Remote Scrolls** 12:00 AM Jun-25-13  
Loaded recipe #: 1

Speed scroll: +/- 1.00 fpm

Analog ratio scroll: +/- 0.0001 : 1

Pulse ratio scroll: +/- 0.0001 : 1

Scroll delay: 1.000 secs

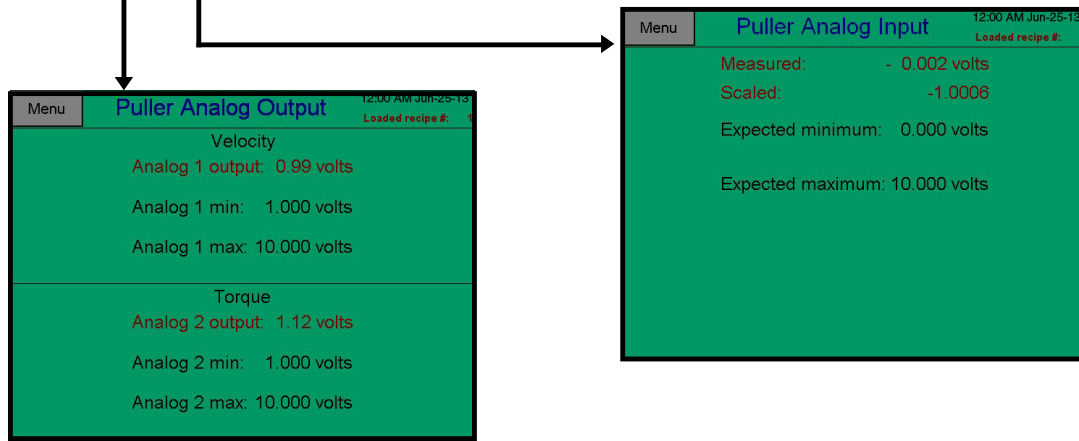

Menu **Puller Analog Output** 12:00 AM Jun-25-13  
Loaded recipe #: 1

Velocity

Analog 1 output: 0.99 volts

Analog 1 min: 1.000 volts

Analog 1 max: 10.000 volts

---

Torque

Analog 2 output: 1.12 volts

Analog 2 min: 1.000 volts

Analog 2 max: 10.000 volts

Menu **Puller Analog Input** 12:00 AM Jun-25-13  
Loaded recipe #: 1

Measured: - 0.002 volts

Scaled: -1.0006

Expected minimum: 0.000 volts

Expected maximum: 10.000 volts

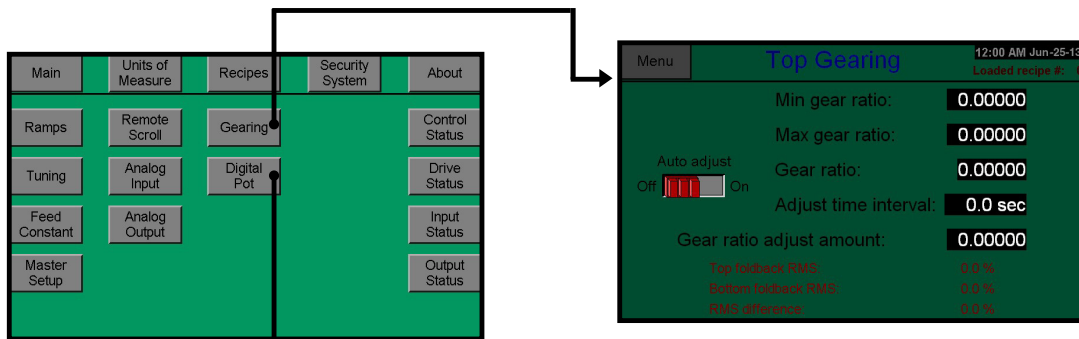

Menu **Top Gearing** 12:00 AM Jun-25-13  
Loaded recipe #: 1

Min gear ratio: 0.00000

Max gear ratio: 0.00000

Auto adjust  
Off  On

Gear ratio: 0.00000

Adjust time interval: 0.0 sec

Gear ratio adjust amount: 0.00000

Top feedback RMS: 0.0 %

Bottom feedback RMS: 0.0 %

RMS difference: 0.0 %

Menu **Digital Pot** 12:00 AM Jun-25-13  
Loaded recipe #: 1

Center: 0.0 uSec

One click: 0.0 uSec

Pot scaling

Speed scroll: +/- 0.00 fpm per click

Analog ratio scroll: +/- 0.0000 per click

Pulse ratio scroll: +/- 0.0000 per click

# The BP Series Belt Puller Flow Charts (continued)

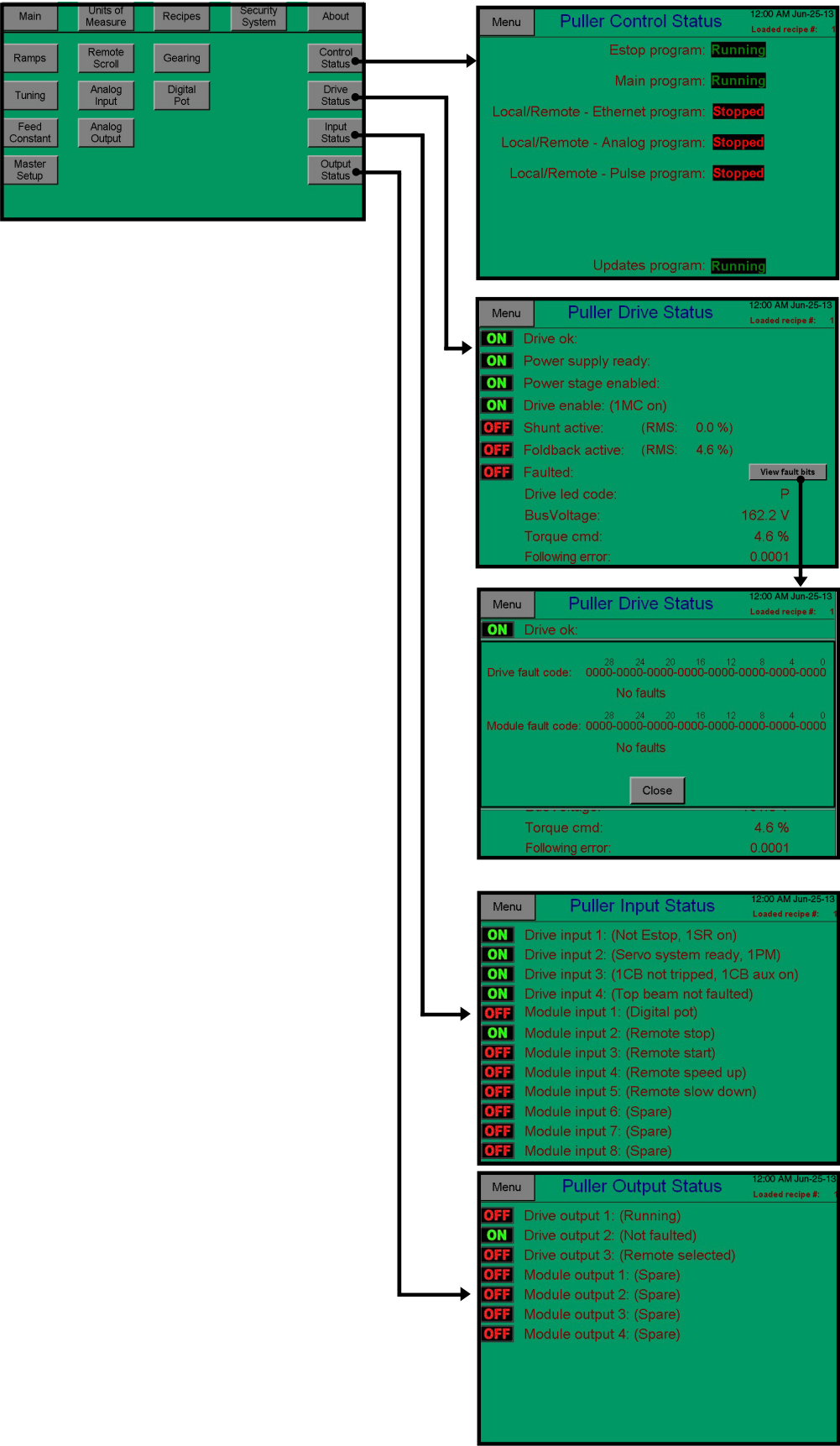

## The BP Series Belt Puller Flow Charts (continued)

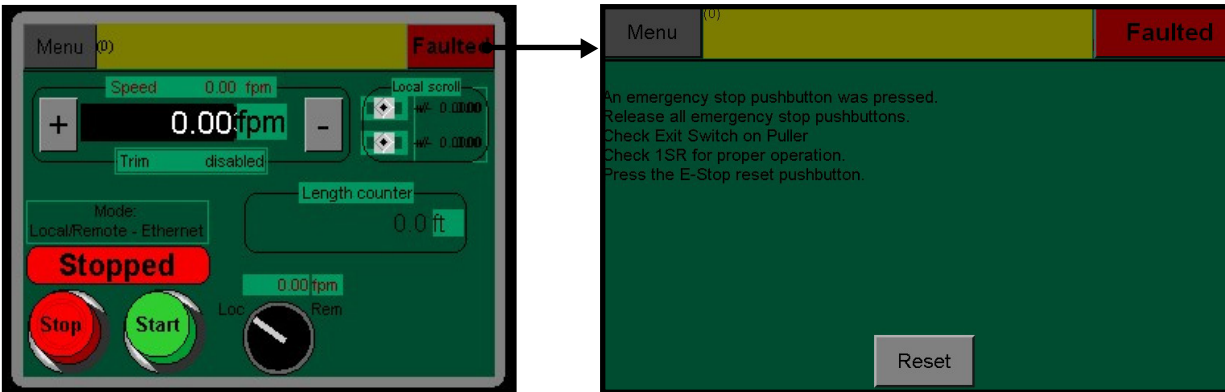

# Control Function Descriptions

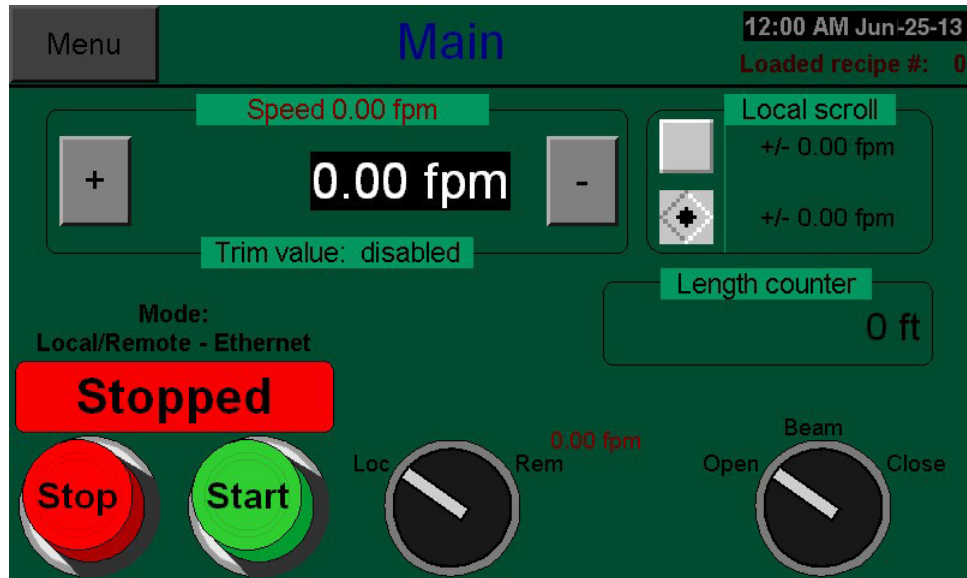

## Main Screen:

This is the main operating screen.

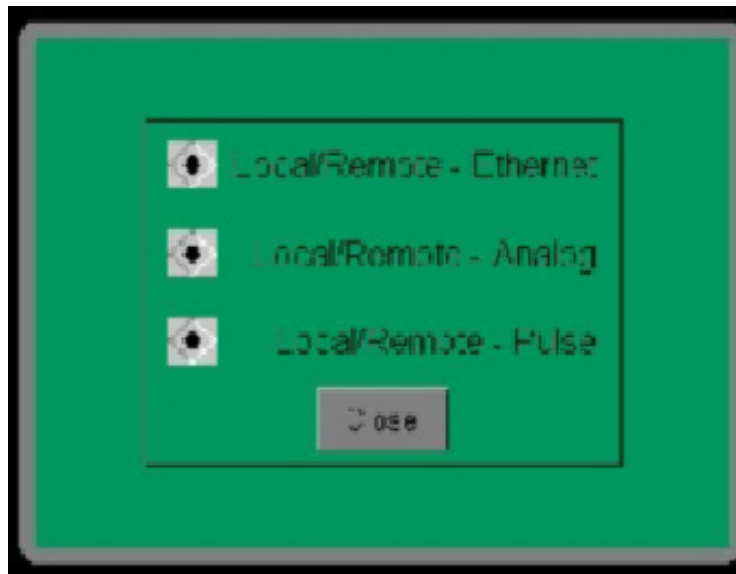

## Puller Modes

This is the screen for selecting the type of input signal being used to control the puller from a secondary source:

- Ethernet - Control is from a logic control system such as an extruder system.
- Analog - Typically a 0-10 V signal coming in from a secondary source.
- Pulse - Puller is following the pulses of an encoder that is tied to a secondary source.

## Control Function Descriptions (continued)

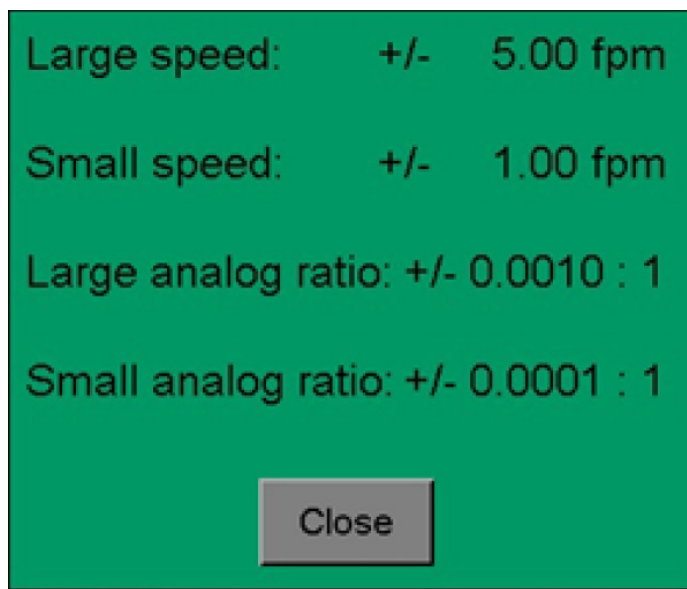

### Local Scroll

This screen appears when the Scroll button is pushed on the main operating screen. It allows the changing of the value of large and small scrolls for the various modes.

- Large/Small speed - When operating the puller in local mode, this is the FPM change that will occur when the up and down arrows on the main operating screen are pushed one time. Pushing the number will bring up a keypad for number entry.
- Large/Small analog ratio - When operating the puller in analog mode, the amount of change to the ratio of the FPM to the input signal voltage can be entered here. A keypad will appear when the number is pushed.
- Large/Small pulse ratio - When operating the machine in pulse mode, the amount of change to the ratio of the FPM to the encoder input pulses can be entered here. A keypad will appear when the number is pushed.

(Continued)

## Control Function Descriptions (continued)

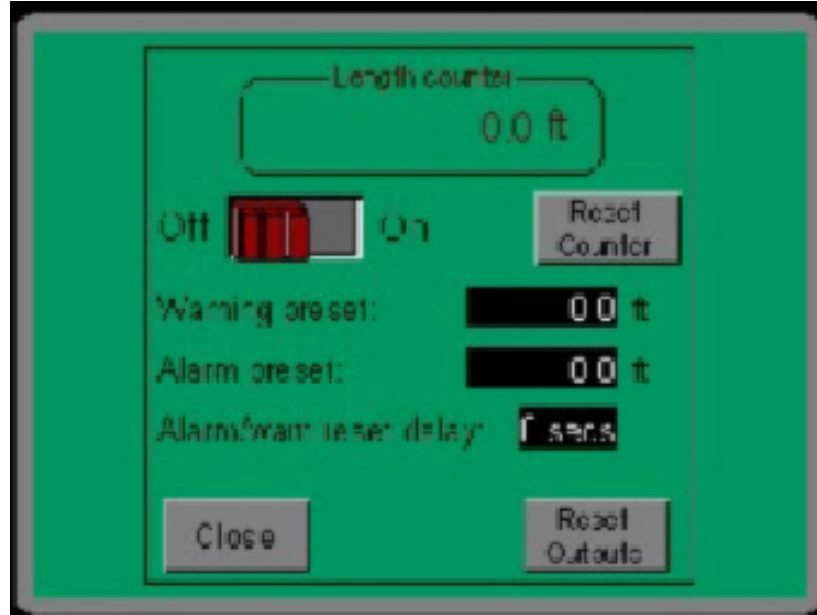

### Length Counters

A This screen will appear when the length counter box is pushed on the main operating screen. It shows the total length of product made.

- On/Off: The length counter can be turned on/off here.
- Reset Counter: The length can also be reset here.
- Warning preset: The puller will give a first warning alarm at the length entered here.
- Alarm preset: The puller will give a final alarm when this entered length is reached.
- Alarm/warn delay: This is the length of time that will elapse before the alarm will reset itself and proceed with the next length count.
- Close: Pushing the close button will return you to the main screen.

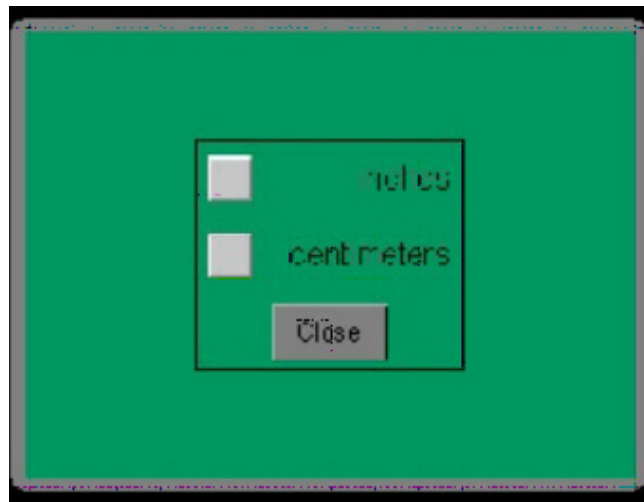

### Units of Measure

This screen is where the units can be selected between standard units and metric units. Touch the box next to the units desired.

# Control Function Descriptions (continued)

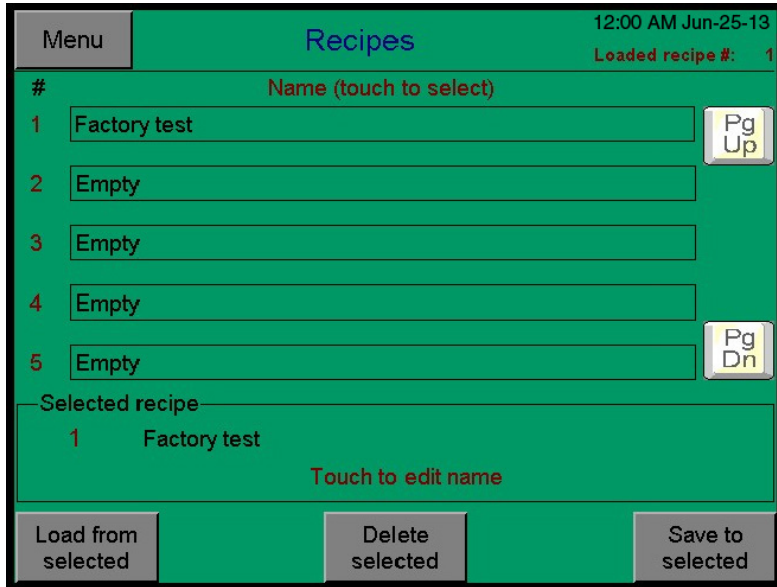

## Recipes

This screen is where the units can be selected between standard units and metric units. Touch the box next to the units desired.

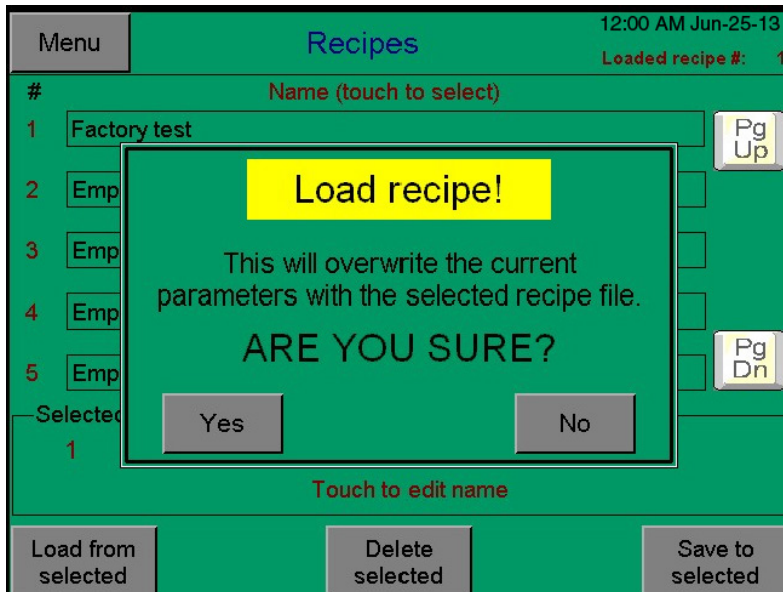

## Load Recipe

The “Load from selected” function is only available when the BP Series Belt Puller is stopped. This function will load the parameters from the recipe file into the active parameters.

(Continued)

## Control Function Descriptions (continued)

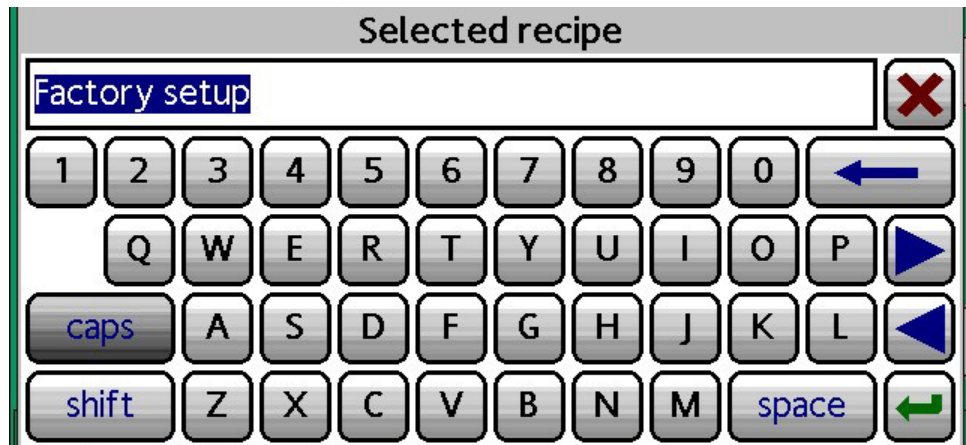

### Recipe Touch to Rename

The "Selected Recipe" key pad can be used to assign or change the name of a recipe. Recipe names are limited to 40 characters.



### Delete Recipe

The "Delete selected" function is available anytime. This function will set the name of the selected recipe file to "Empty". The actual parameter values in the recipe file are not deleted.

## Control Function Descriptions (continued)

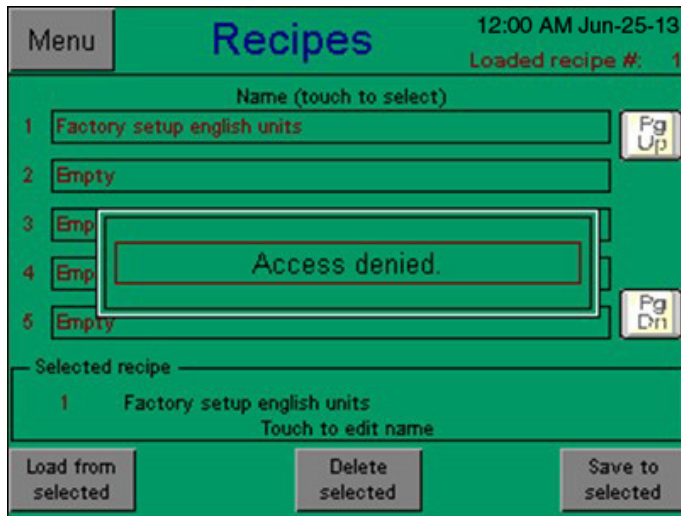

### Recipe Delete Access Denied

The Recipe Delete “Access denied” pop-up will appear if the User tries to delete a recipe without the proper authority (password access). To correct this situation, log in as a User with proper authority.



### Recipe Save

Individual recipes can be saved using this pop-up screen. Up to 99 different recipes can be saved. A saved recipe will collect all set points of the current BP Series Belt Puller when it is saved. Recipes can be saved at any time. Recipes can only be loaded when the machine is in the stopped condition. This function will save the active parameters to the selected recipe file.

(Continued)

## Control Function Descriptions (continued)

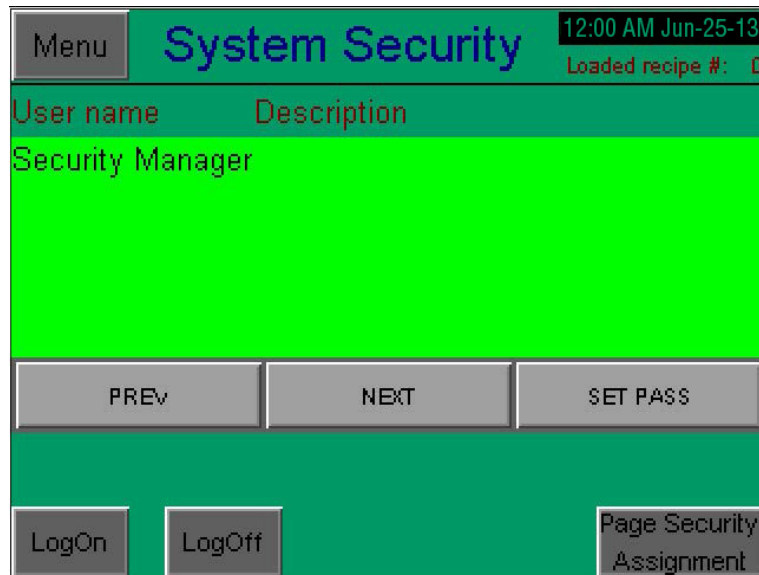

### Security System

The System Security screen is used to create a password for a User and to “LogOn” to and “LogOff” of the system. There are five different User choices. The “Set Pass” button takes the User to the Security Manager screen where the password is assigned. Once the password has been assigned, the “LogOn” and “LogOff” buttons can be used to access the system. Setting the accessibility of each User to the various screens can be done by pushing the Security Assignment button.



### Security System Logon

The Security Manager pop-up allows the user to assign a password and user access level for the user. The admin has the clearance to change all passwords by selecting the Set Pass button.

## Control Function Descriptions (continued)

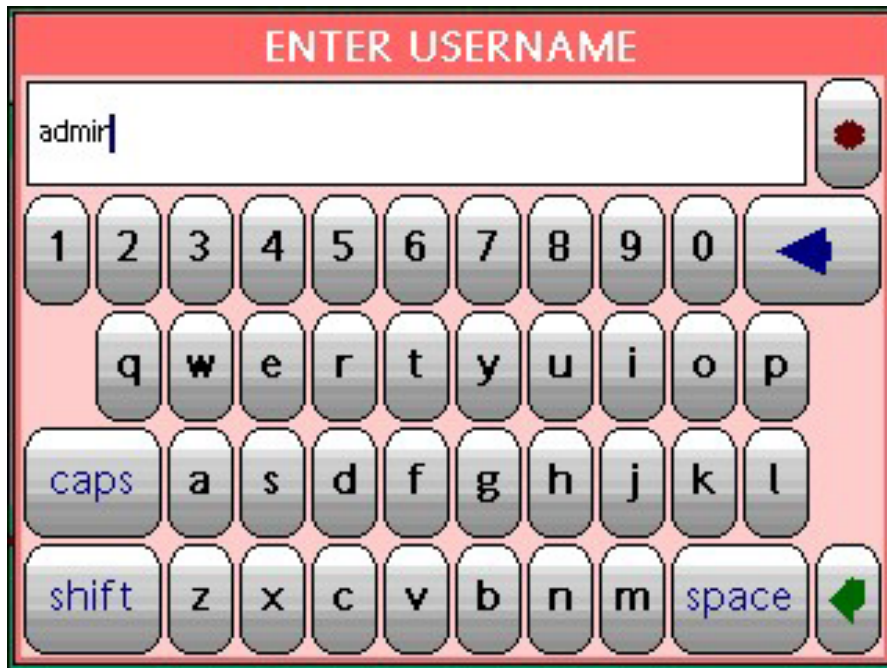

### Security Enter Username

The Enter "User Name" Key Pad pop-up allows the User to enter the User's name.



### Security Enter Password

The Enter Password Keypad pop-up allows the User to enter the User's password.

(Continued)

## Control Function Descriptions (continued)

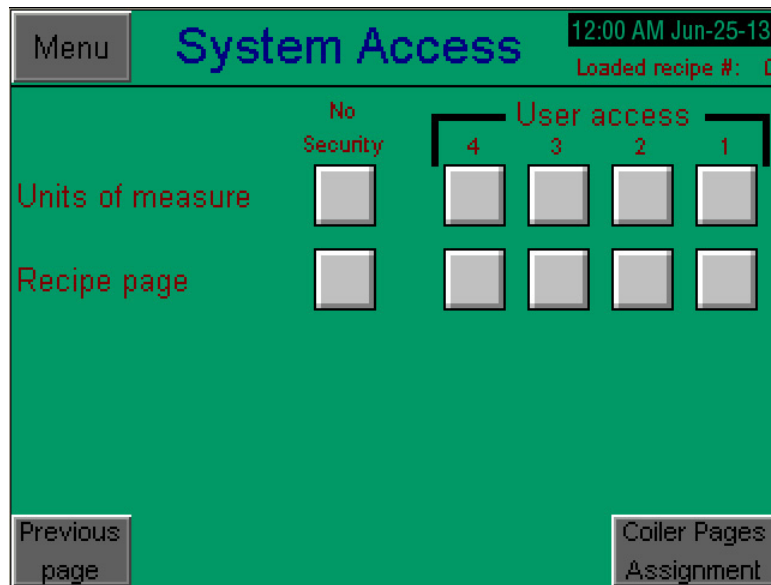

### System Security Access

The System Access screen is used to give access to the Units of Measure and Recipe Screen functions. Access can be granted as “No Security” or to specific Users.



### About

This screen displays Coniar’s contact information. It also lists the version information of the Crimson programming software used to create the HMI screens. Touch screen calibration is accessed from this screen by pushing the Touch Calibrate button.

## Control Function Descriptions (continued)

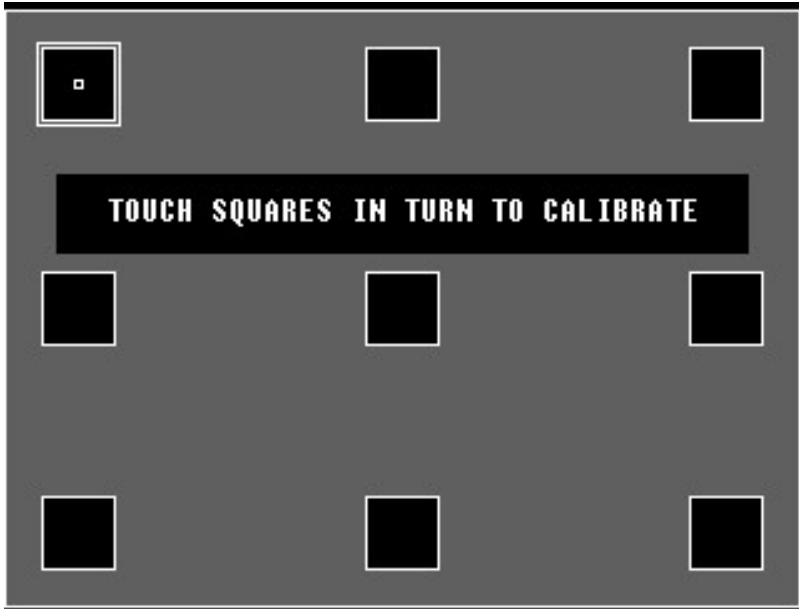

### Touch Calibrate

The squares highlight one at a time. Once all nine squares have been touched in the order highlighted, calibration will be complete. If Calibration fails, a red warning message will appear; otherwise a Calibration Success message will be seen.



### Touch Calibrate Successful

The "Calibration Was Successful" message will appear if the calibration process was successful.

(Continued)

## Control Function Descriptions (continued)

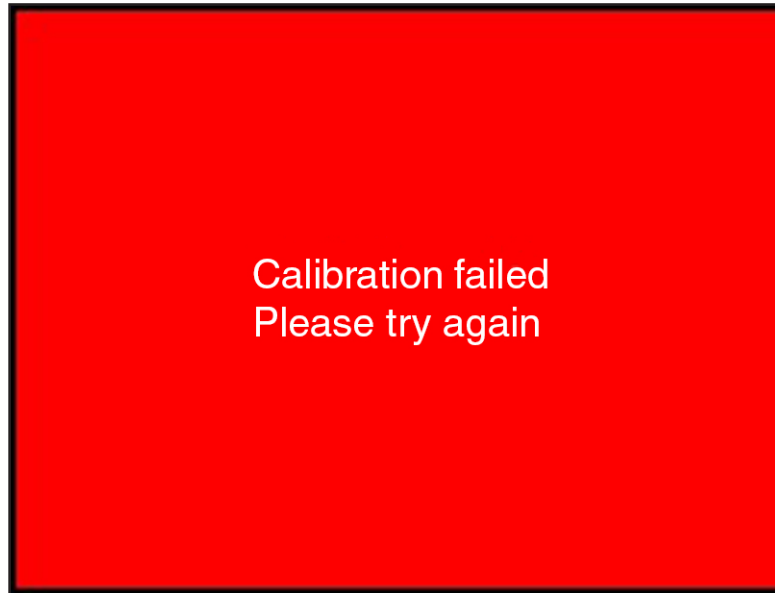

### Touch Calibrate Failed

The “Calibration failed. Please try again” message will appear if the calibration process failed. If the calibration process failed, repeat the calibration process.

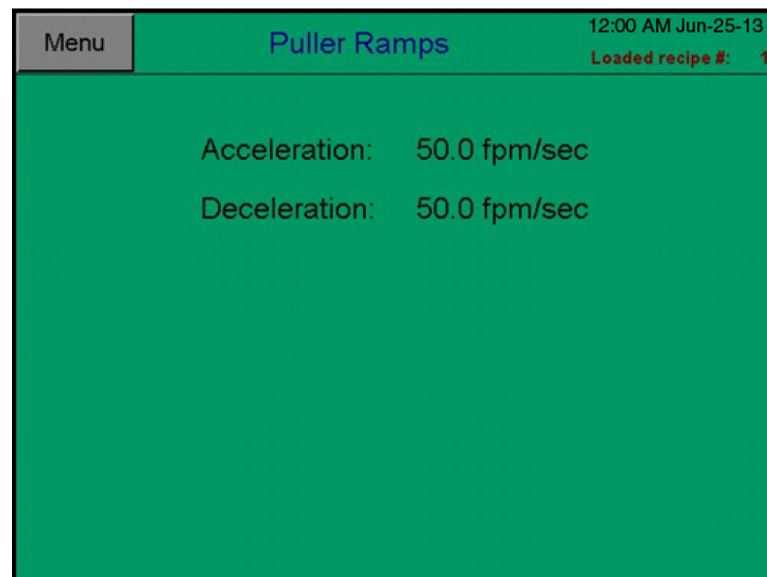

### Puller Ramps

This screen allows access to the puller acceleration and deceleration parameters. The acceleration and deceleration controls how quickly the puller will change from one speed setting to another.

Acceleration: This parameter controls the rate at which the puller accelerates.

Deceleration: This parameter controls the rate at which the puller decelerates

# Control Function Descriptions (continued)

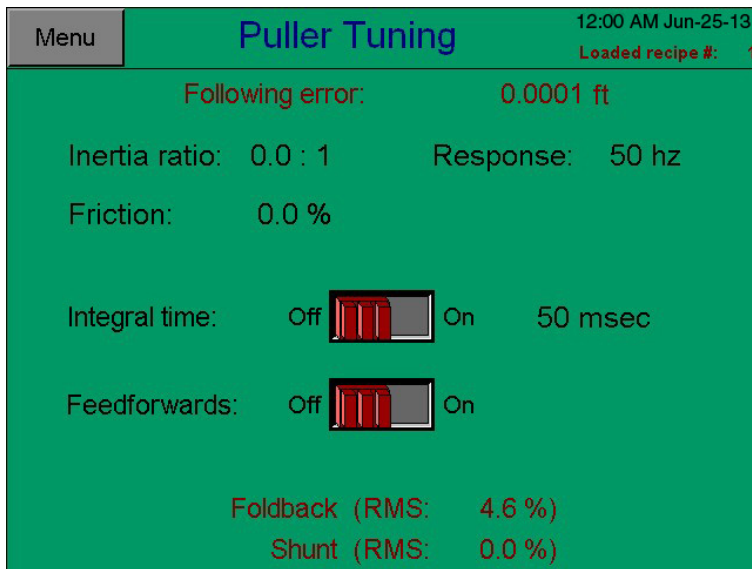

## Puller Tuning

This screen allows access to the puller servo tuning parameters. These parameters will affect how tightly the puller servo controls the speed of the servo motor. These parameters are adjusted at the factory and generally do not need to be adjusted by the customer.

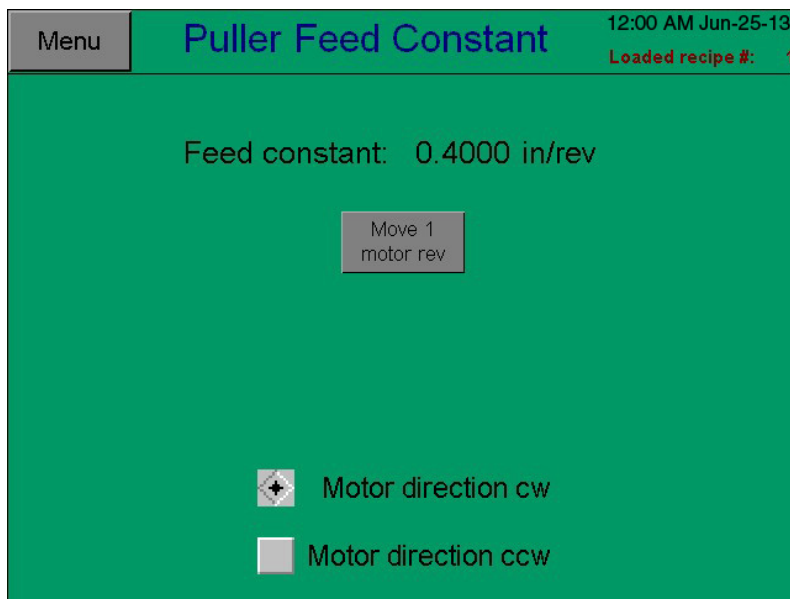

## Puller Feed Constant

This screen allows access to the puller feed constant parameters. The feed constant scales the speed units (ie. ft/min) to motor rpm.

Feed Constant: This parameter scales 1 motor revolution to the selected units of measure.

## Control Function Descriptions (continued)

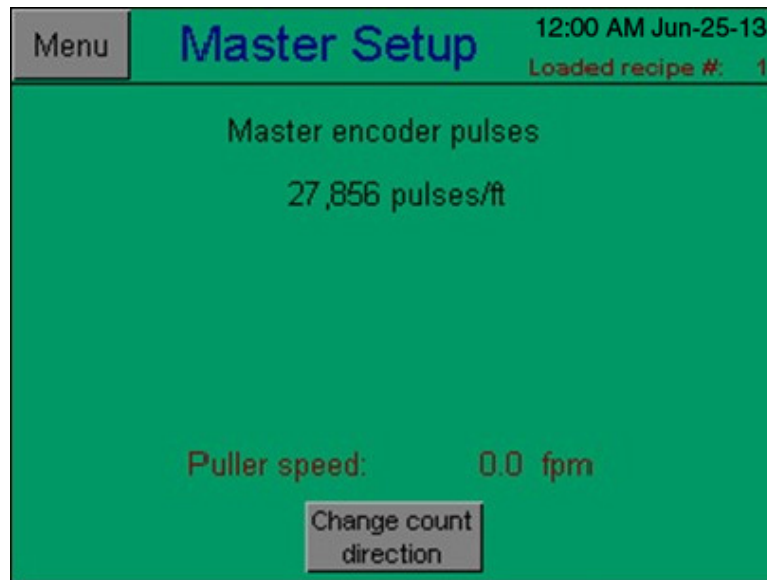

### Master Setup

This screen allows access to the master encoder input scaling parameters. The puller speed can be controlled by a quadrature encoder input signal provided by the customer. These parameters scale encoder pulses to puller speed.

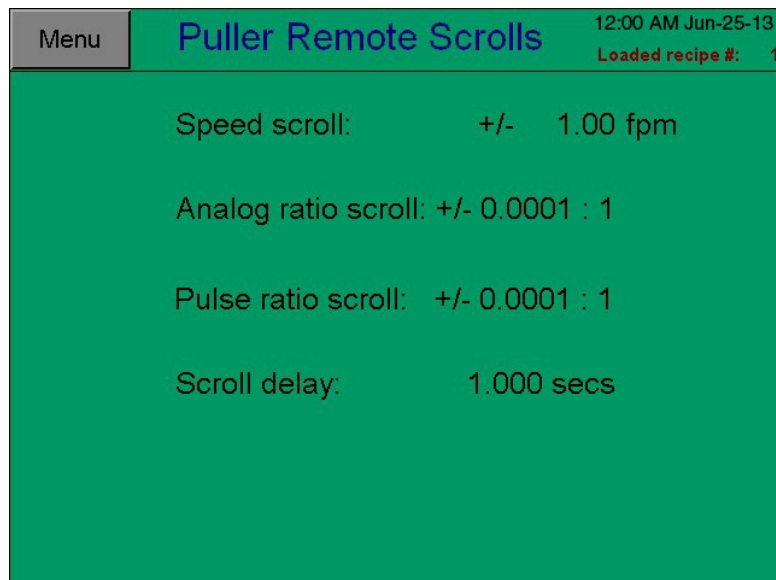

### Remote Scroll

This screen allows access to the puller remote speed scroll parameters. The puller speed can be adjusted by means of dry contact closures provided by the customer. The speed of the puller can be adjusted up or down by these contacts. The amount of speed adjustment can be set by these parameters.

# Control Function Descriptions (continued)

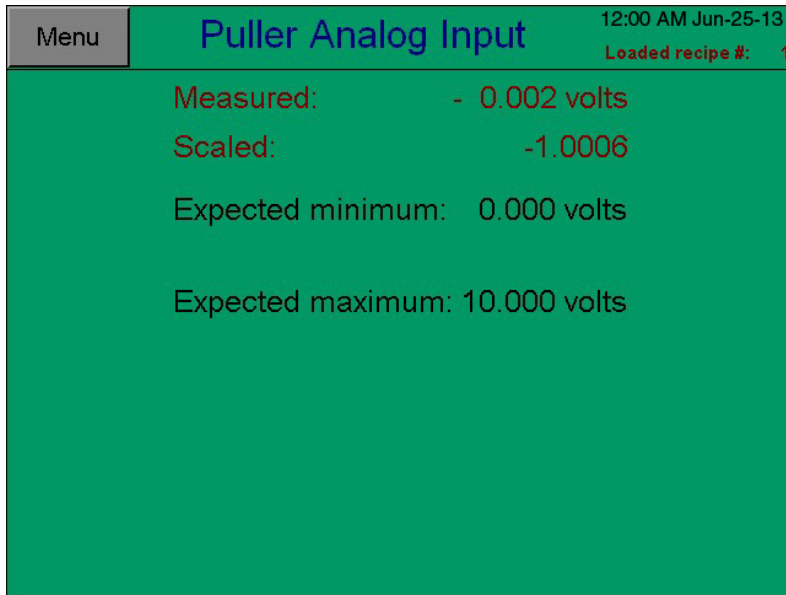

## Puller Analog Input

This screen allows access to the puller analog input scaling parameters. The puller speed can be controlled by a 0-10 VDC analog input provided by the customer. These parameters can be adjusted to match the actual minimum and maximum analog value provided.

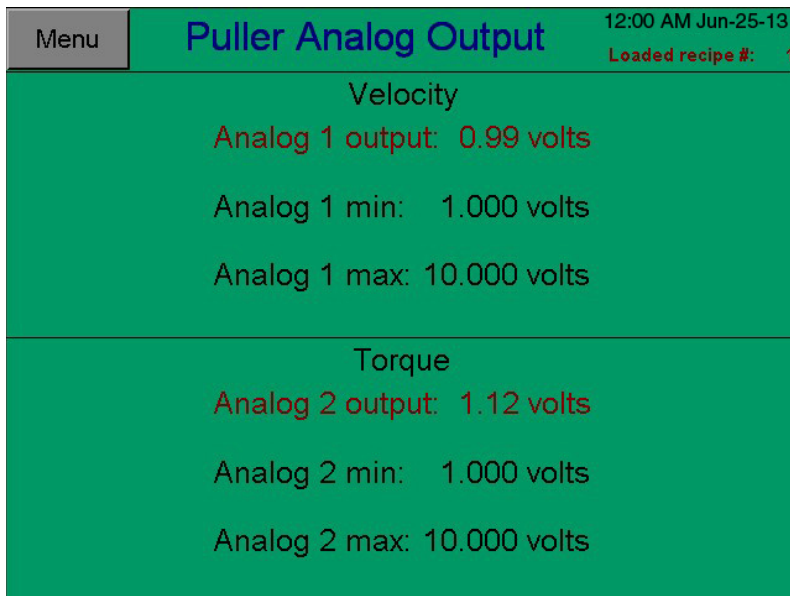

## Puller Analog Output

This page allows access to the puller analog output scaling parameters. The puller provides two 0-10 VDC analog outputs, one is proportional to actual puller speed, the other proportional to motor running torque. These parameters can adjust the minimum and maximum voltage of the analog outputs.

(Continued)

## Control Function Descriptions (continued)

Menu	Top Gearing		12:00 AM Jun-25-13
		Min gear ratio:	0.00000
		Max gear ratio:	0.00000
	Auto adjust	Gear ratio:	0.00000
	Off  On	Adjust time interval:	0.0 sec
		Gear ratio adjust amount:	0.00000
		Top foldback RMS:	0.0 %
		Bottom foldback RMS:	0.0 %
		RMS difference:	0.0 %

### Top Gearing

Contact Conair Parts and Service 1 800 458 1960. From outside of the United States, call: 814 437 686

The settings on this screen are factory set and should not need adjusted. If adjustments are necessary, consult with Conair.

Menu	Digital Pot		12:00 AM Jun-25-13
	Captured time:		0 uSec
+1 click:	0 uSec	Learn	-1 click: 0 uSec
	Center:		0.0 uSec
	One click:		0.0 uSec
	Pot scaling		
	Speed scroll:		+/- 0.00 fpm per click
	Analog ratio scroll:		+/- 0.0000 per click
	Pulse ratio scroll:		+/- 0.0000 per click

### Digital Pot

These settings adjust the ratio for each click of the digital potentiometer. This is used to make adjustments, down to very small increments.

(Continued)

# Control Function Descriptions (continued)

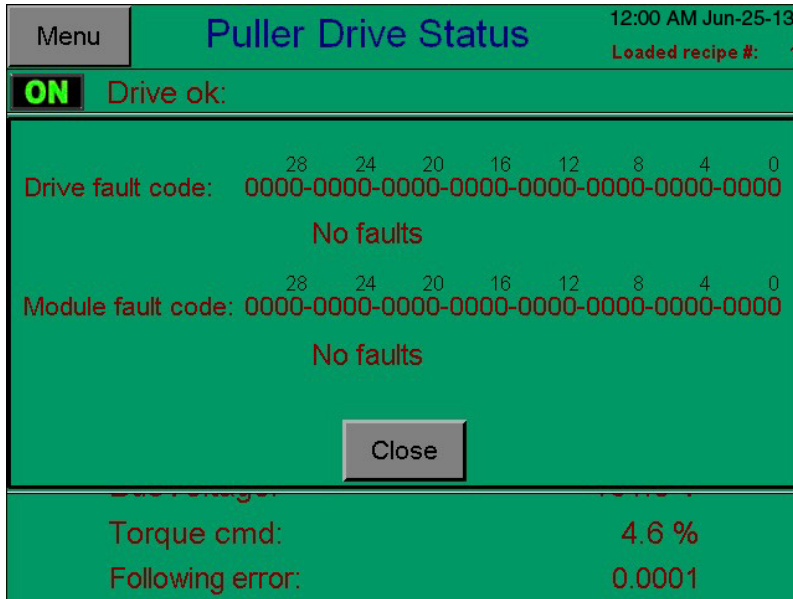

## Puller Drive Status Faults

This is used to describe the fault bits for troubleshooting and service.

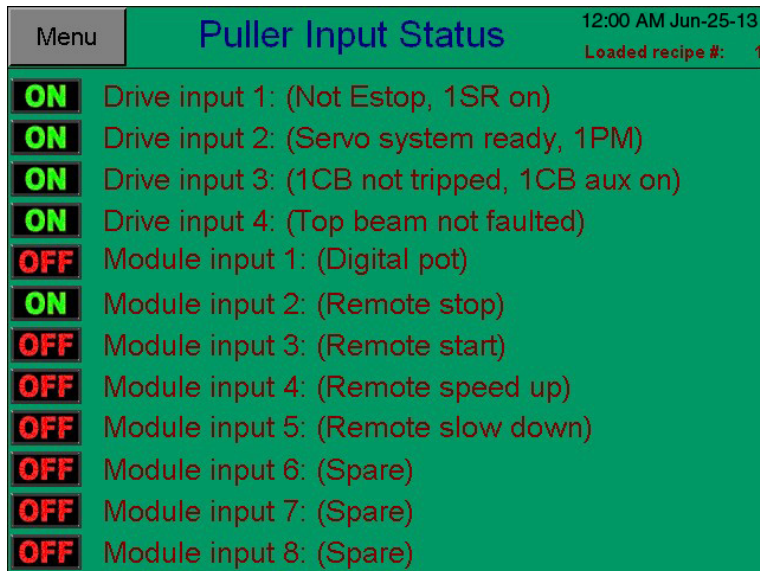

## Puller Input Status

The Input Status screen shows the On/Off status of the servo controller inputs. This information is only valid when the emergency stop circuit is reset. This information is provided for troubleshooting purposes.

## Control Function Descriptions (continued)

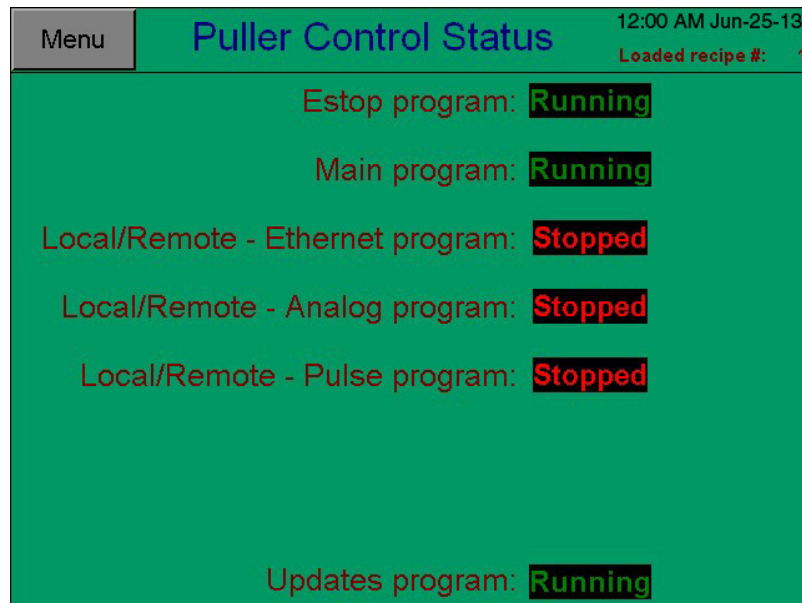

### Puller Control Status

This screen allows access to the puller servo control module status. The information displayed on this screen would be used to help troubleshoot problems encountered with the puller.

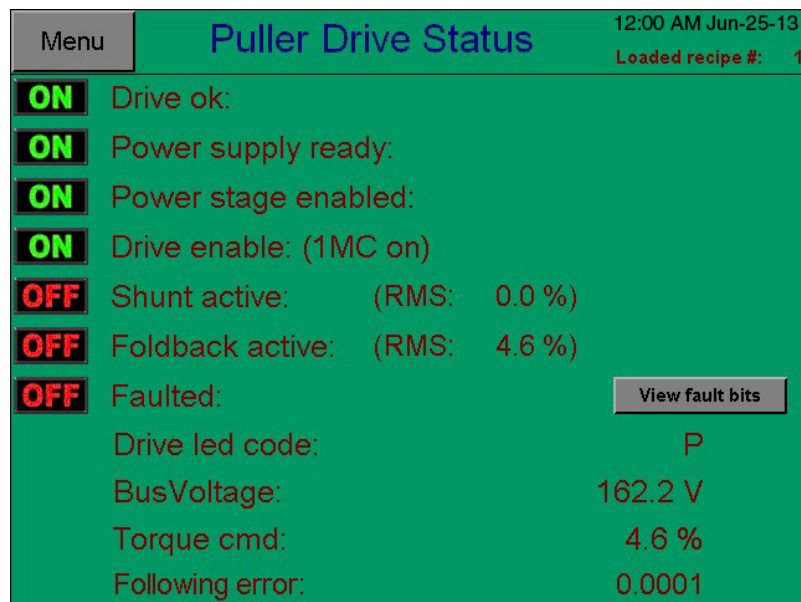

### Puller Drive Status

This screen allows access to the puller servo drive module status. The information displayed on this screen would be used to help troubleshoot problems encountered with the puller.

## Control Function Descriptions (continued)

Menu	<b>Puller Analog Output</b>	12:00 AM Jun-25-13 Loaded recipe #: 1
Velocity		
Analog 1 output: 0.99 volts		
Analog 1 min: 1.000 volts		
Analog 1 max: 10.000 volts		
Torque		
Analog 2 output: 1.12 volts		
Analog 2 min: 1.000 volts		
Analog 2 max: 10.000 volts		

### Puller Output Status

The Output Status screen shows the On/Off status of the servo controller outputs. This information is only valid when the emergency stop circuit is reset. This information is provided for troubleshooting purposes.

Menu	(0)	<b>Faulted</b>
<p>An emergency stop pushbutton was pressed. Release all emergency stop pushbuttons. Check Exit Switch on Puller Check 1SR for proper operation. Press the E-Stop reset pushbutton.</p>		
<input type="button" value="Reset"/>		

### Alarm Messages

A fault indicator/button will appear in the upper right of the page if a machine fault occurs. Pressing this button will show the fault message pop-up box. The reset button will reset the fault as long as the condition that created the fault is corrected. When the fault is reset, the fault indicator will disappear.



# Maintenance

---

Preventative Maintenance Schedule .....	5-2
Replacing the Belts .....	5-5
Lubricating Shafts and Fittings.....	5-6
Checking Electrical Connections.....	5-7

# Preventative Maintenance Schedule



**WARNING: Moving Parts.**



**Improper servicing may result in equipment damage or personal injury.**

This equipment should be adjusted and serviced by qualified technical personnel who are familiar with the construction, operation, and potential hazards of this type of machine.

Before performing maintenance or repairs on this product, disconnect and lock out electrical power sources to prevent injury from unexpected energization or start-up. A lockable device has been provided to isolate this product from potentially hazardous electricity.

Make sure all safety devices and belt guards are installed before resuming normal operation.

To maintain the best performance of the puller, we recommend the following maintenance schedule. You may need to shorten the time between servicing, depending on how often you use the belt puller, and the types of material flowing through it. Maintenance should be performed anytime you change materials, lines or equipment in the extrusion line.

All bearings are sealed and lubricated for life.

Check the tension on all the belts during the first three (3) weeks of operation for looseness, and correct if necessary. After the three (3) weeks, continue to check every three (3) months. Replace any damaged traction belts with new ones.

Continued on next page

# Preventative Maintenance Schedule

## (continued)

- **Daily**
  - Clean any debris from the haul-off surfaces.**
  - Remove any material from the belt surface**, or any which may be caught between the V-belt and the rolls.
  - Verify that all the guards are in place.**
  - Adjust the product guide rolls to the size of the extrusion.**
  - Verify that all the control cabinet doors are closed tightly.**
  - Check the alignment of the haul-off** with the extrusion line (parallel to line and proper center-height).
- **Weekly**
  - Check the condition of the haul-off belt surfaces.**
  - Verify the tension of the haul-off belts.** With a firm grip, pull up at the center of the belt. It should rise approximately 1/2 of an inch.
- **Quarterly (every 3 months)**
  - Disconnect the power from the haul-off.**
  - Check the chain drive** for proper tension. Clean and grease if necessary.
  - Check that the oil** in the gear reducers is at the proper level, and that there are no leaks.
  - Clean and grease the spindle controls and chain ways (if applicable).**
  - Grease the conveyor support bushings and the chain (if applicable).**
  - Remove the conveyor belts** and inspect for wear or cracking. Replace if necessary. Make sure to check and correct the belt tension.
  - Clean the V-grooves in the belts.** Inspect and clean the rolls. Re-install the V-belt rolls and the conveyors belt and ensure that the belt tension is correctly set. The tension adjustments on the idler rolls should be set so that the rolls run true with the belts.
  - With the power disconnected** from the haul-off, blow or vacuum any dust or dirt from the control panels.
  - Verify that all the electrical connections are tight.**
  - Verify, with a hand-held tachometer**, that the motor speed is stable through the whole speed range of the haul-off.
  - With the speed potentiometer set to full**, check that the motor RPM is approximately 1750 rpm.

## Preventative Maintenance Schedule (continued)

- **Semiannually (every 6 months)**
  - Change the oil in the worm gear reducer every 2500 hours of running time or every six months depending on which comes first.**  
Recommended oil: 50° to 125°F. (ambient temperature)  
AGMA, compound #8, for example:
    - Exxon Cyclesstic TK-680
    - Gulf Senate 680D
    - Mobile Extra Hecla Super
    - Shell Valvata J680
  
  - Check the chain drive for any wear and elasticity, and replace if necessary.**  
Replace any damaged or worn chains, sprockets or traction belts with new ones.
- **Annually (once a year)**
  - Verify electrical connection and tighten screw where needed in main box.**
  - Inspect pneumatic tubes for any signs of damage.**
  - Check that the oil in the gear reducers is at the proper level, and that there are no leaks.**

### Recommended Lubricator Oil

Tellus 21, but any high quality oil in the 80/350 second (Redwood No. 1) at 70°F. range is suitable.

# Replacing the Belts



**WARNING: Moving Parts.**



**Improper servicing may result in equipment damage or personal injury.**

This equipment should be adjusted and serviced by qualified technical personnel who are familiar with the construction, operation, and potential hazards of this type of machine.

Before performing maintenance or repairs on this product, disconnect and lock out electrical power sources to prevent injury from unexpected energization or start-up. A lockable device has been provided to isolate this product from potentially hazardous electricity.

Make sure all safety devices and belt guards are installed before resuming normal operation.

**1 Turn the main power disconnect to the off position.**

**2 Remove the belt guards.**

Remove the screws attaching guards to the unit (four on each guard: top, bottom, front and rear). Disconnect the safety cable on the upper guard. Lift off and remove guard.

**3 Release the belt tension.**

Loosen the threaded rods, making sure you keep tension on front and back edges as even as possible. Turn each rod 5 to 10 revolutions, then switch to the other side. Continue until the belt is loose enough to slide off the puller.

**4 Remove the belt from the puller.**

Check the rollers and pulleys for buildup, especially inside grooves. Clean if necessary.

**5 Reverse the process to install the new belt.**

Make sure ribs inside the belt fit properly into grooves. Keep tension on front and back sides of the belt as even as possible while tightening the belt tension. Turn each rod 5 to 10 revolutions, then switch to the other side.

**6 Adjust belt tension and belt gap.**

See [Adjusting the Belt Tension](#) and [Setting the Belt Gap](#) in the *Installation* section.

**7 Reinstall the upper and lower belt guards.**

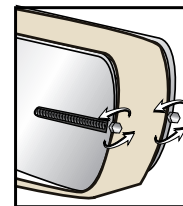

## Lubricating Shafts and Fittings

You should check the shafts and grease fittings weekly, and lubricate as needed.

Lubricate thread rods and vertical shafts with Never-Seize or an equivalent lubricant.

You can use regular grease on all other locations.

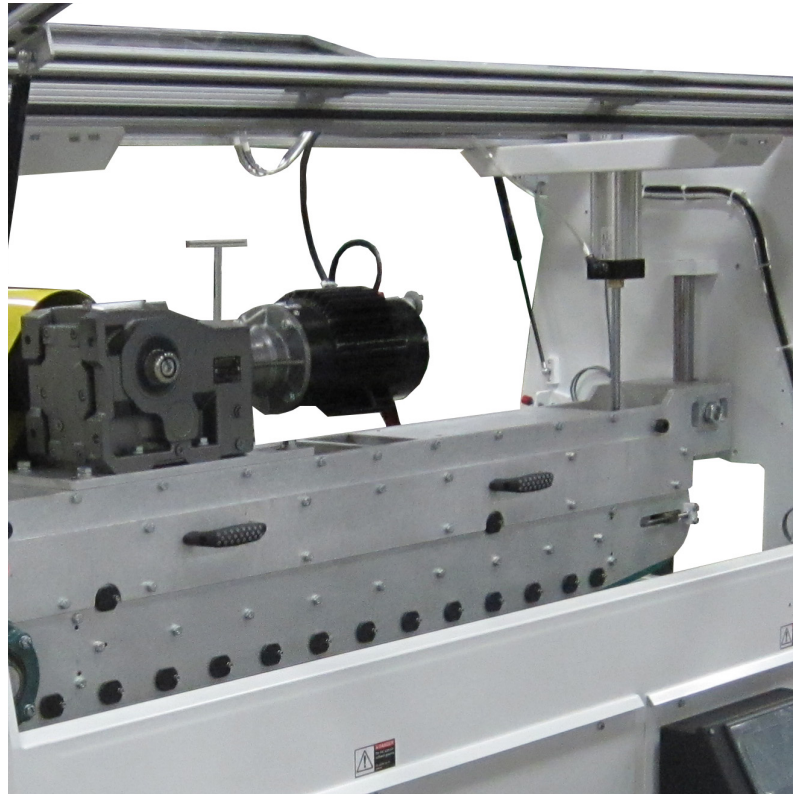

# Checking Electrical Connections



## **WARNING: Electrical hazard**

Before performing any work on this product, disconnect and lock out electrical power sources to prevent injury from unexpected energization or start-up. A lockable device has been provided to isolate this product from potentially hazardous electricity.



## **WARNING: Improper servicing may result in equipment damage or personal injury.**

This equipment should only be adjusted, and serviced by qualified technical personnel who are familiar with the construction, operation, and potential hazards of this type of machine.

All wiring, disconnects, and fuses should be installed by qualified electrical technicians in accordance with electrical codes in your region. Always maintain a safe ground. Do not operate the equipment at power levels other than what is specified on the machine serial and data plate.

### **1 Disconnect and lock out the main power.**

Turn the main power disconnect to the off position before opening the electrical enclosure on the back of the puller. This is a safety device to prevent you from opening the doors if the power is still on.

### **2 Open the electrical enclosure.**

### **3 Inspect all wires and connections.** Look for loose wires, burned contacts, and signs of over-heated wires. Have a qualified electrician make any necessary repairs or replacements.

### **4 Close the electrical enclosure door.**

### **5 Inspect the exterior power cords.** Cords should not be crimped, exposed, or rubbing against the frame. If the main power cord runs along the floor, make sure it is not positioned where it could rest in pooling water or could be run over and cut by wheels or casters.



# Introduction

---

Purpose of the User Guide .....	1-2
How the Guide is Organized .....	1-2
Your Responsibility as a User .....	1-2
ATTENTION: Read This So No One Gets Hurt.....	1-3
How to Use the Lockout Device .....	1-4

# Purpose of the User Guide

This User Guide describes the Conair BP Series Belt Pullers and explains step-by-step how to install, operate, maintain and repair this equipment.

Before installing this product, please take a few moments to read the User Guide and review the diagrams and safety information in the instruction packet. You should also review manuals covering associated equipment in your system. This review won't take long, and it could save you valuable installation and operating time later.

# How the Guide is Organized

Symbols have been used to help organize the User Guide and call your attention to important information regarding safe installation and operation.



Symbols within triangles warn of conditions that could be hazardous to users or could damage equipment. Read and take precautions before proceeding.



Numbers indicate tasks or steps to be performed by the user.



A diamond indicates the equipment's response to an action performed by the user or a situation.



An open box marks items in a checklist.



A circle marks items in a list.



Indicates a tip. A tip is used to provide you with a suggestion that will help you with the maintenance and the operation of this equipment.



Indicates a note. A note is used to provide additional information about the steps you are following throughout the manual.

# Your Responsibility as a User

You must be familiar with all safety procedures concerning installation, operation, and maintenance of this equipment. Responsible safety procedures include:

- Thorough view of this User Guide, paying particular attention to hazard warnings, appendices, and related diagrams.
- Thorough review of the equipment itself, with careful attention to voltage sources, intended use, and warning labels.
- Thorough review of instruction manuals for associated equipment.
- Step-by-step adherence to instructions outlined in this User Guide.

# ATTENTION: Read This So No One Gets Hurt

We design equipment with the user's safety in mind. You can avoid the potential hazards identified on this machine by following the procedures outlined below and elsewhere in the User Guide.



## **DANGER: Moving parts; pinch hazard**



Safety devices have been installed on this machine to prevent injury that could result from clothing or the operator becoming caught in moving traction belts. Never remove or disable safety devices to sustain production. Operating without these devices could lead to hazardous conditions that can cause severe injury.

- Walk-through style belt guards protect from injury, but also allow side entry for ease of operation. Upper and lower belt guards independently protect the operator from being caught in the belts or associated driven sheaves
- The emergency stop (E-stop) button is located on the upstream side of the control box. When pressed, it works in parallel with the guard switch to disconnect power to the belt drive. The E-stop must be physically pulled up to reset the switch and start the puller again..



## **WARNING: Improper installation, operation, or servicing may result in equipment damage or personal injury.**

This equipment should be installed, adjusted, and serviced by qualified technical personnel who are familiar with the construction, operation, and potential hazards of this type of machine.

All wiring, disconnects, and fuses should be installed by qualified electrical technicians in accordance with electrical codes in your region. Always maintain a safe ground. Do not operate the equipment at power levels other than what is specified on the machine serial tag and data plate.



## **WARNING: Voltage hazard**



This equipment is powered by three-phase alternating current, as specified on the machine serial tag and data plate.

A properly-sized conductive ground wire from the incoming power supply must be connected to the chassis ground terminal inside the electrical enclosure. Improper grounding can result in severe personal injury and erratic machine operation.

**Always disconnect and lockout power before opening the electrical enclosure or performing non-routine procedures such as maintenance.**

## How to Use the Lockout Device

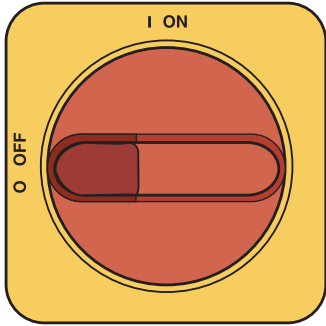

### **WARNING: Electrical hazard**

Before performing maintenance or repairs on this product, you should disconnect and lockout electrical power sources to prevent injury from unexpected energization or start-up. A lockable device has been provided to isolate this product from potentially hazardous electricity.



### **CAUTION: Moving parts**

Before removing lockout devices and returning switches to the ON position, make sure that all personnel are clear of the machine, tools have been removed and all safety guards reinstalled.

Lockout is the preferred method of isolating machines or equipment from energy sources. Your Conair product is equipped with the lockout device pictured below. To use the lockout device:

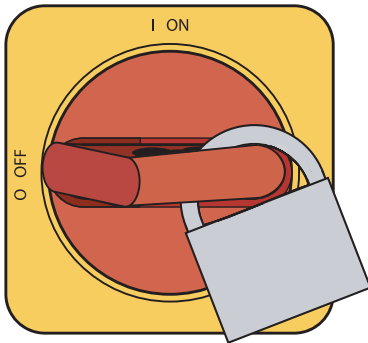

- 1 Stop or turn off the equipment.**
- 2 Isolate the equipment from the electric power.** Turn the rotary disconnect switch to the OFF, or “O” position.
- 3 Secure the device with an assigned lock or tag.** Insert a lock or tag in the holes to prevent movement.
- 4 The equipment is now locked out.**



**WARNING:** Before removing lockout devices and returning switches to the ON position, make sure that all personnel are clear of the machine, tools have been removed and all safety guards reinstalled.

To restore power to the device, turn the rotary disconnect back to the ON position:

- 1 Remove the lock or tag.**
- 2 Turn the rotary disconnect switch to the ON or “I” position.**



**NOTE:** Your lockout device may not look identical to this one. The illustration is for reference only.

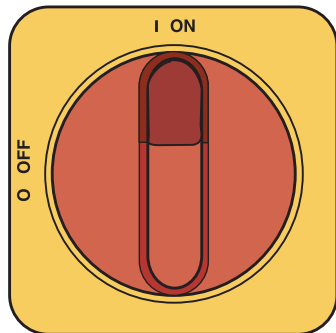

# Troubleshooting

---

Before Beginning .....	6-2
A Few Words of Caution.....	6-2
Identifying the Cause of a Problem .....	6-3
Operation Problems .....	6-4
Product Quality Problems .....	6-5

## Before Beginning

You can avoid most problems by following the recommended installation, operation and maintenance procedures outlined in this User Guide. If you have a problem, this section will help you determine the cause and tell you how to fix it.

Before you begin troubleshooting:

- Find any wiring, parts, and assembly diagrams that were shipped with your equipment.** These are the best reference for correcting a problem. The diagrams will note any custom features or options not covered in this User Guide.
- Verify that you have all instructional materials related to the puller.** Additional details about troubleshooting and repairing specific components are found in these materials.
- Check that you have manuals for other equipment connected in the system.** Troubleshooting may require investigating other equipment attached to, or connected with the control.

## A Few Words of Caution



**WARNING: Improper servicing may result in equipment damage or personal injury.**

This equipment should only be installed, adjusted, and serviced by qualified technical personnel who are familiar with the construction, operation, and potential hazards of this type of machine.

All wiring, disconnects, and fuses should be installed and adjusted by qualified electrical technicians in accordance with electrical codes in your region. Always maintain a safe ground. Do not operate the equipment at power levels other than what is specified on the machine serial tag and data plate.



**WARNING: Electrical hazard**

Before performing maintenance or repairs on this product, disconnect and lock out electrical power sources to prevent injury from unexpected energization or start-up. A lockable device has been provided to isolate this product from potentially hazardous electricity.

# Identifying the Cause of a Problem

The Troubleshooting section covers problems directly related to the operation and maintenance of the standard belt puller. This section does not provide solutions to problems that originate with other equipment. Additional troubleshooting help can be found in manuals supplied with the other equipment.

The main problems you will see with the pullers are:

- **Puller operation problems**, which focus on problems that are clearly related to the puller's mechanical components and electrical control system.
- **Product quality concerns**, which deal with extrudate characteristics that may be related to puller operation. Of course, other sections of the extrusion line also influence the quality of the extruded product. This section does not provide solutions to problems originating with other equipment on the extrusion line.

Additional troubleshooting help can be found in the documentation manuals included with this User Guide.

# Operation Problems

Look in this section when the control or motor is not working properly.

Symptom	Possible Cause	Solution
The puller 'creaks' while running.	The belt is too tight.	Check the belt tension; loosen if necessary. <i>See <a href="#">Adjusting Belt Tension in the Installation section</a>.</i>
	The bearings are failing.	Replace the bearings.
The puller does not start.	The E-stop button is pushed in.	Pull out the E-stop button. Make sure it clicks into position.

# Product Quality Problems

Look in this section when the extrudate shows annular rings in the cross-sectional cut of the product.

Symptom	Possible Cause	Solution
Annular rings present on the extrudate.	The belt puller is too close to the cutter.	If the extrudate is interrupted (stopped during processing), annular rings can develop, especially on a thin-walled product. Slightly increase the distance between the puller and the cutter, and test the product until the distance is correct.
	The anti-backlash bearings are not working properly.	Stop the puller and try to move the lower belt by hand. The lower belt should not be able to travel backwards when you try to move it. If it does, the anti-backlash bearings must be replaced. Contact Conair Service.
Wall thickness fluctuation on the extrudate.	There are variations in the speed of the puller..	<p><b>Check:</b></p> <ul style="list-style-type: none"> <li><input type="checkbox"/> If motor brushes are worn.</li> <li><input type="checkbox"/> The belts for cracks and wear. Replace as necessary.</li> <li><input type="checkbox"/> For material buildup under the belts. Clean as needed.</li> <li><input type="checkbox"/> The bearings for wear; replace as needed.</li> </ul>
Diameter fluctuation on the extrudate.	There are variation in the speed of the puller.	<p><b>Check:</b></p> <ul style="list-style-type: none"> <li><input type="checkbox"/> For material buildup under the belts. Clean as needed.</li> <li><input type="checkbox"/> The bearings for wear; replace as needed.</li> <li><input type="checkbox"/> If motor brushes are worn. (applies to optional DC motor)</li> <li><input type="checkbox"/> The belts for cracks and wear. Replace as necessary.</li> </ul>



# We're Here to Help

Conair has made the largest investment in customer support in the plastics industry. Our service experts are available to help with any problem you might have installing and operating your equipment. Your Conair sales representative also can help analyze the nature of your problem, assuring that it did not result from misapplication or improper use.

**Additional manuals and prints for your Conair equipment may be ordered through the Customer Service or Parts Department for a nominal fee. Most manuals can be downloaded free of charge from the product section of the Conair website.**  
[www.conairgroup.com](http://www.conairgroup.com)

## How to Contact Customer Service

To contact Customer Service personnel, call:



 **NOTE:** Normal operating hours are 8:00 am - 5:00 pm EST. After hours emergency service is available at the same phone number.

**From outside the United States, call: 814-437-6861**

You can commission Conair service personnel to provide on-site service by contacting the Customer Service Department. Standard rates include an on-site hourly rate, with a one-day minimum plus expenses.

## Before You Call...

**If you do have a problem, please complete the following checklist before calling Conair:**

- Make sure you have all model, control type from the serial tag, and parts list numbers for your particular equipment. Service personnel will need this information to assist you.
- Make sure power is supplied to the equipment.
- Make sure that all connectors and wires within and between control systems and related components have been installed correctly.
- Check the troubleshooting guide of this manual for a solution.
- Thoroughly examine the instruction manual(s) for associated equipment, especially controls. Each manual may have its own troubleshooting guide to help you.
- Check that the equipment has been operated as described in this manual.
- Check accompanying schematic drawings for information on special considerations.

## Equipment Guarantee

Conair guarantees the machinery and equipment on this order, for a period as defined in the quotation from date of shipment, against defects in material and workmanship under the normal use and service for which it was recommended (except for parts that are typically replaced after normal usage, such as filters, liner plates, etc.). Conair's guarantee is limited to replacing, at our option, the part or parts determined by us to be defective after examination. The customer assumes the cost of transportation of the part or parts to and from the factory.

## Performance Warranty

Conair warrants that this equipment will perform at or above the ratings stated in specific quotations covering the equipment or as detailed in engineering specifications, provided the equipment is applied, installed, operated, and maintained in the recommended manner as outlined in our quotation or specifications.

Should performance not meet warranted levels, Conair at its discretion will exercise one of the following options:

- Inspect the equipment and perform alterations or adjustments to satisfy performance claims. (Charges for such inspections and corrections will be waived unless failure to meet warranty is due to misapplication, improper installation, poor maintenance practices, or improper operation.)
- Replace the original equipment with other Conair equipment that will meet original performance claims at no extra cost to the customer.
- Refund the invoiced cost to the customer. Credit is subject to prior notice by the customer at which time a Return Goods Authorization Number (RGA) will be issued by Conair's Service Department. Returned equipment must be well crated and in proper operating condition, including all parts. Returns must be prepaid.

Purchaser must notify Conair in writing of any claim and provide a customer receipt and other evidence that a claim is being made.

## Warranty Limitations

**Except for the Equipment Guarantee and Performance Warranty stated above, Conair disclaims all other warranties with respect to the equipment, express or implied, arising by operation of law, course of dealing, usage of trade or otherwise, including but not limited to the implied warranties of merchantability and fitness for a particular purpose.**

# Using the Digital Belt Gap Sensor (Option)

The optional digital belt gap sensor uses a linear scale attached to both belts to measure the relative distance between the belts. The relative distance is shown in thousandths of an inch (.001). The sensor has five buttons:

- On/Off - Turns the device on and off.
- Mode - Press to choose the readout in decimals, fractions, or millimeters.
- + - Press to move up one engineering unit.
- 0 - Press to zero the reading. Because all measurements are relative, the sensor can be set to zero at any time by pressing this button.
- - - press to move down one engineering unit.

Readings display on the digital display.

For more information, refer to the belt gap sensor manual.

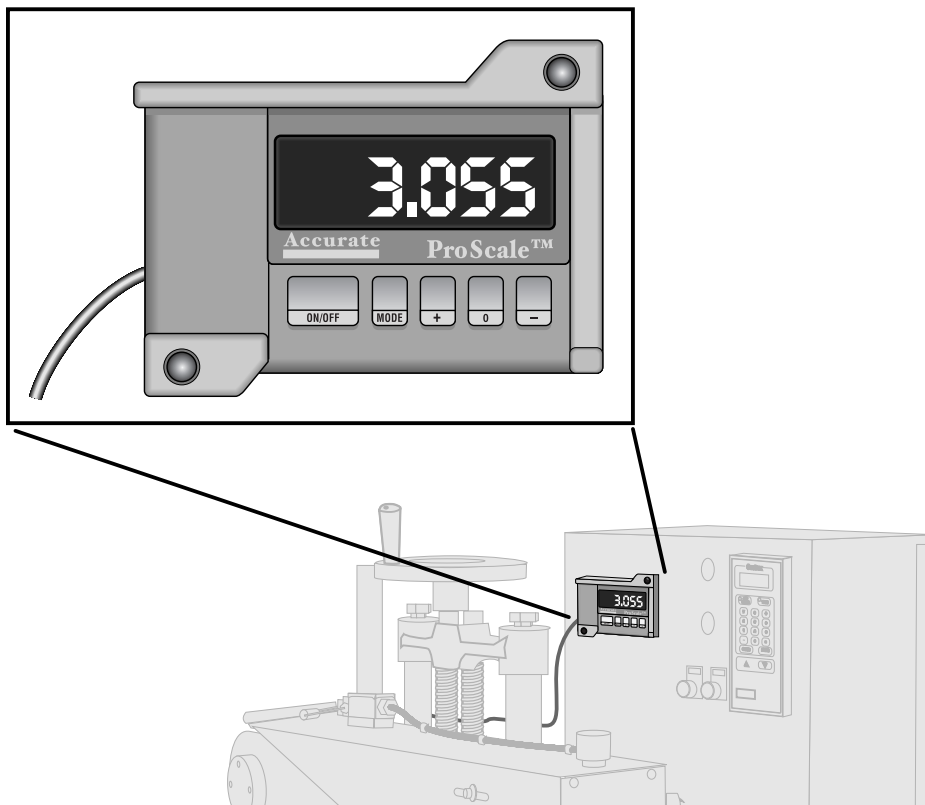

## Adjusting the Pneumatic Upper Belt Actuator (Option)

You can adjust the speed of the optional air cylinder assembly that operates the upper belt boom assembly. Choose which airline you want opened. Move the handle (shown) to direct the air through the tubing:

- When the handle is in the upper position, air is open to the top air line and closed to the bottom airline.
- Move the handle to the down position and the air is closed to the top air line and open to the bottom air line.

Open up the back of the puller and set the speed of the air cylinder assembly by adjusting the flow control valves on the cylinder.

