

USERGUIDE

Telemecanique ATV 58 Speed Driver



WARNING - Reliance on this Manual Could Result in Severe Bodily Injury or Death!

This manual is out-of-date and is provided only for its technical information, data and capacities. Portions of this manual detailing procedures or precautions in the operation, inspection, maintenance and repair of the product forming the subject matter of this manual may be inadequate, inaccurate, and/or incomplete and cannot be used, followed, or relied upon. Contact Conair at info@conairgroup.com or 1-800-654-6661 for more current information, warnings, and materials about more recent product manuals containing warnings, information, precautions, and procedures that may be more adequate than those contained in this out-of-date manual.

I – DESCRIPTION

I – 1. Coding

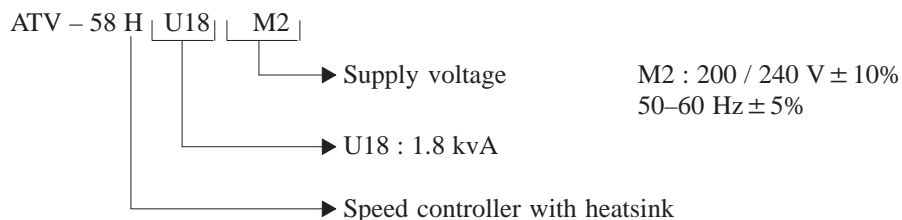

I – 2. Introduction

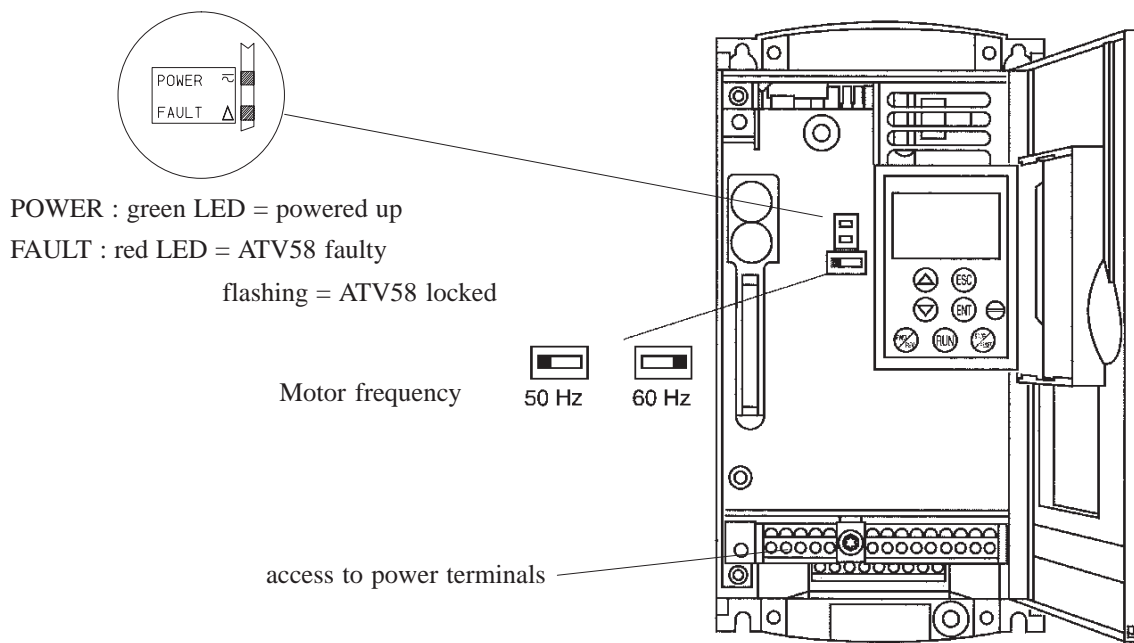
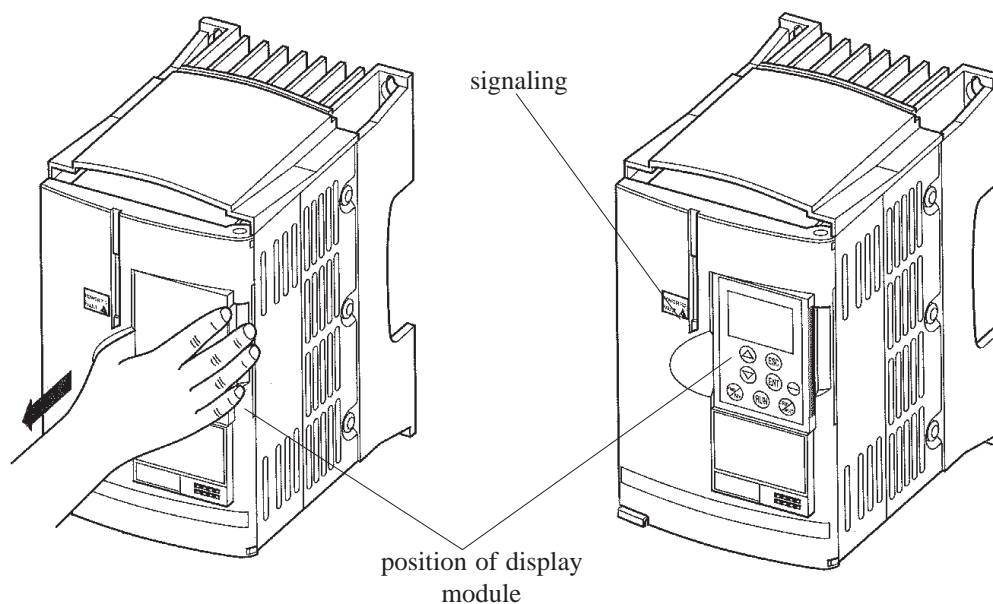

II – CONNECTION DIAGRAM

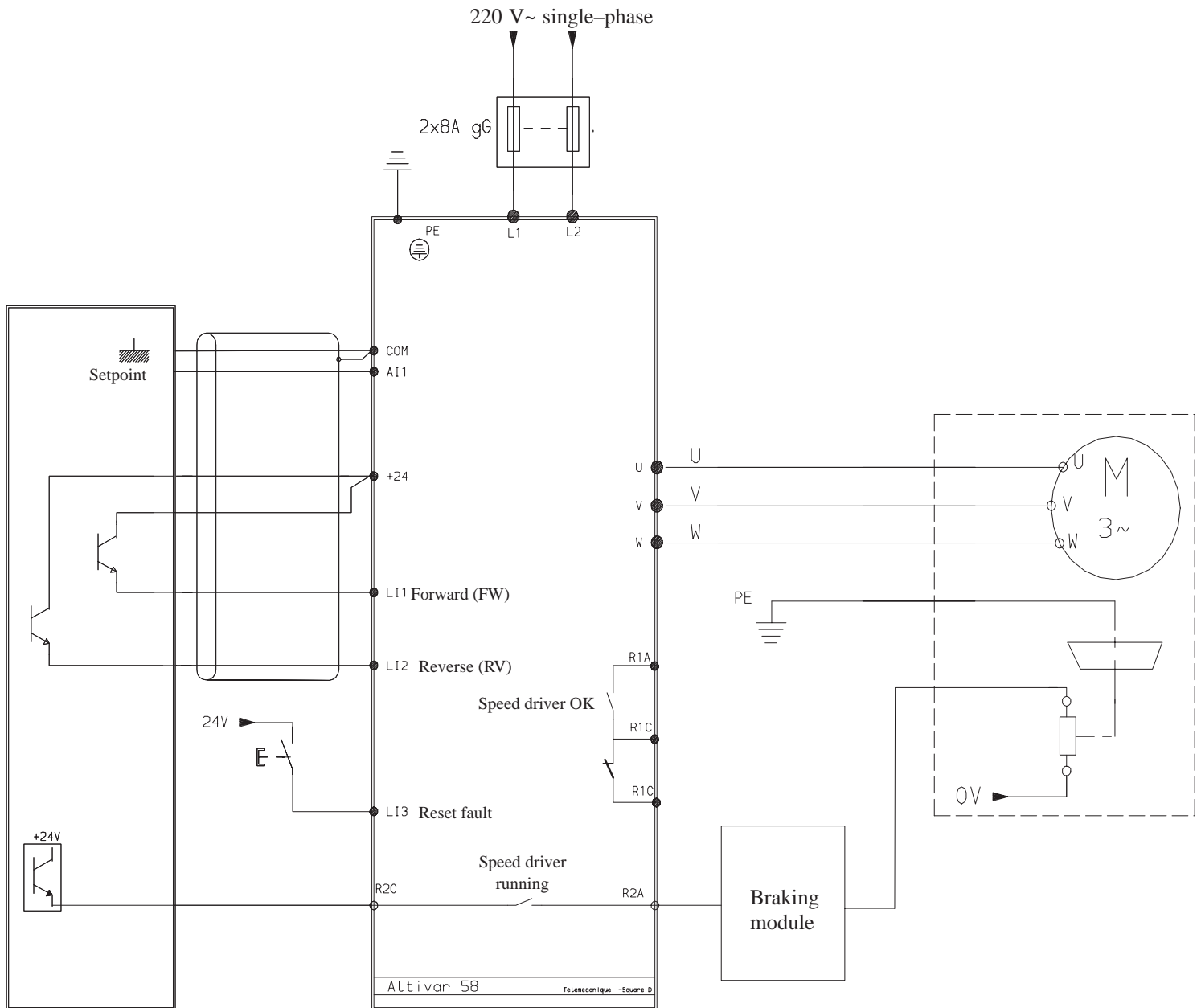

III – POWER TERMINALS

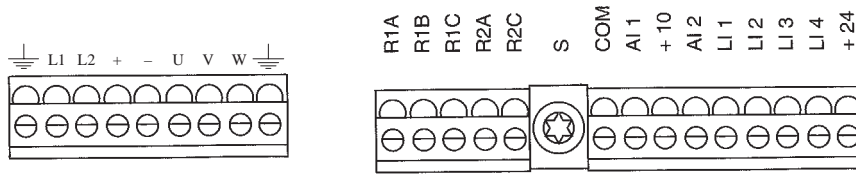

Terminal	Function	Characteristics
⏏	Ground	–
L1, L2	Power supply	220 Vsingle-phase
+, –	Outputs to braking resistor	Not used
U, V, W	Outputs to motor	230 V, 50 Hz*
R1A, R1B, R1C	NO and NC contact of fault relay (DRIVER OK)	Max 1.5 A for 24V=
R2A, R2C	NO contact of R2 relay programmed as “speed driver running”	
S	Connection for cable shielding	–
COM	Common for speed setpoint and logic inputs	0 V
AI1	Speed setpoint input	0V / +10 V
+10	Power supply for setpoint potentiometer	Not used
AI2	Speed setpoint input (current)	Not used
LI1	Programmable logic input for forward operation (FW)	+24
LI2	Programmable logic input for reverse operation (RV)	+24
LI3	Programmable logic input for Drive reset fault	+24
LI4	Logic input 4	Not used
+24	Power supply for inputs	Max 200 mA

* the motor torque may vary depending on the axis' configuration. See parameters UNS and FRS.

IV – DISPLAY MODULE

Reference : VW3 – A58 101

IV – 1. Presentation

Front panel

Lit up : indicates the motor rotation direction
 Flashing : indicates the selected rotation direction.

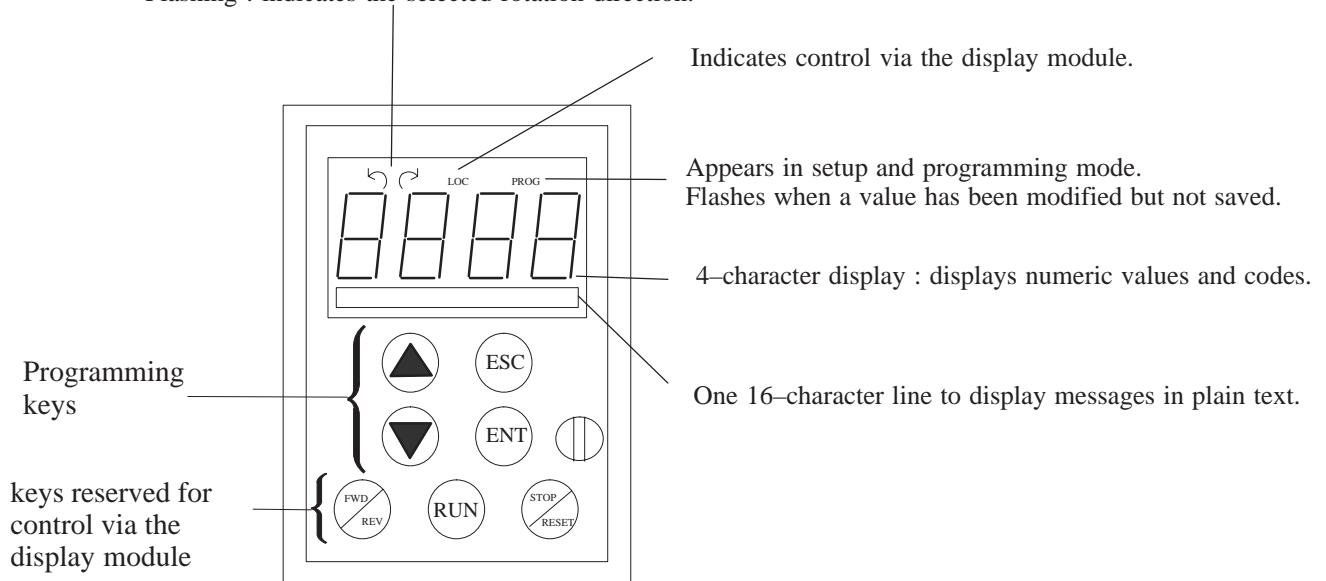

Rear panel

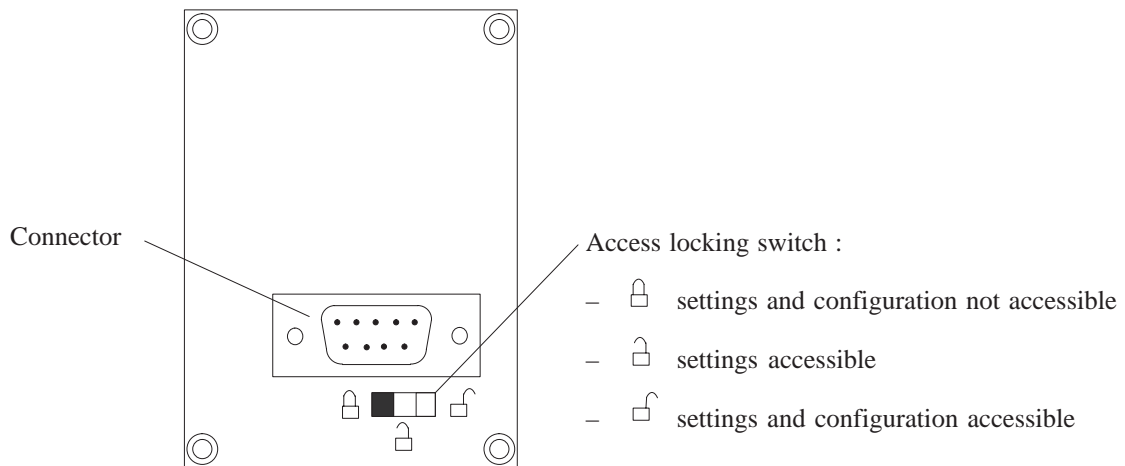

Note : the display module can be connected or disconnected when the speed driver is powered up.

IV – 2. Access to menus

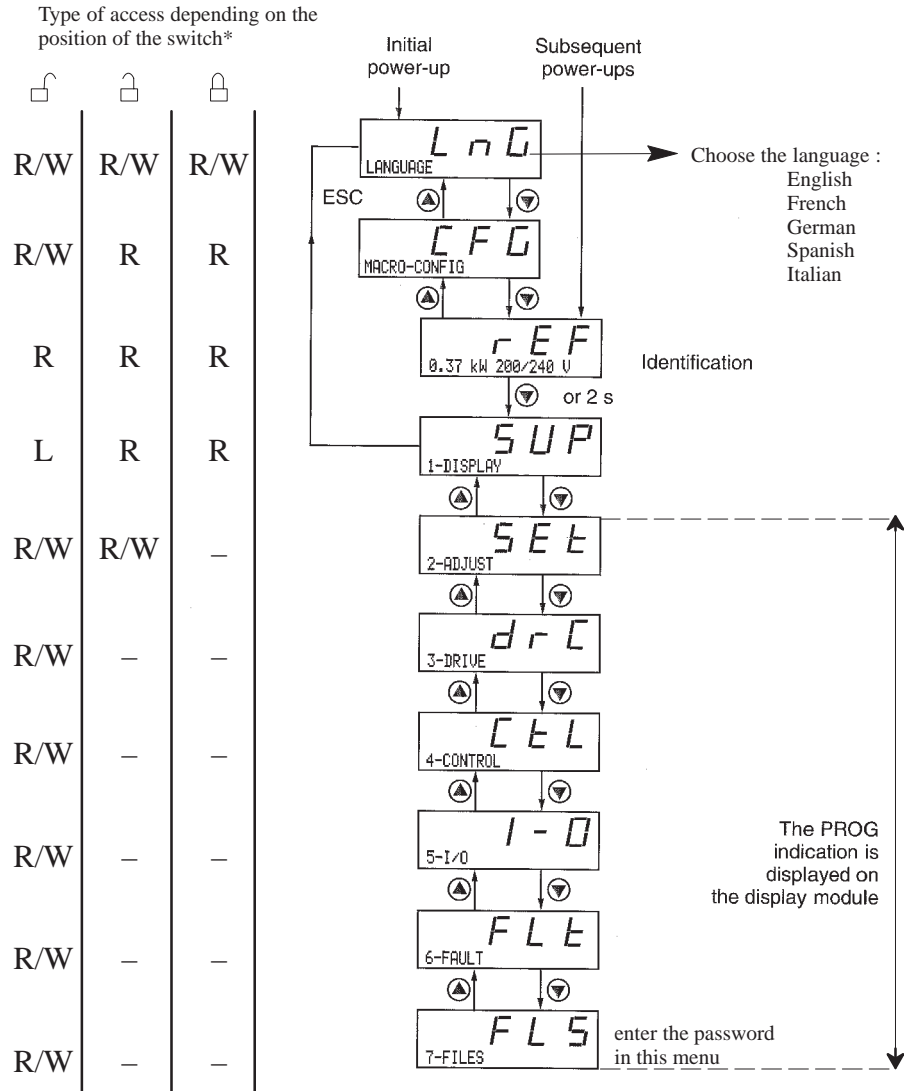

*R/W : read and write access once the password has been entered
R : read access only

The Sepro password is 5859.

Note : This password gives access to the hidden advanced drive menu (menu number 9).

IV – 3. Selection – Modification in a menu

ENT : used to enter a menu or confirm the selection.

ESC : used to exit a menu or cancel the current modification.

▲ ▼: used for selection in the different menus and to change the numeric values.

V – PARAMETERS

Here is an example of parameters.

Code	Label	Value	Default value	Logic address
	Macro-configurations			
CFG	Macro-configuration	Hdg:Handling	Hdg:Handling	3
CUS	Customized	<u>Yes</u>	No	486
	Adjustments			
ACC	Acceleration	<u>0,05 s</u>	3,0 s	252
DEC	Deceleration	<u>0,05 s</u>	3,0 s	253
AC2	Acceleration 2	5,0 s	5,0 s	260
DE2	Deceleration 2	5,0 s	5,0 s	261
LSP	Low Speed	0,0 Hz	0,0 Hz	251
HSP	High Speed	<u>94,0 Hz</u>	50,0 Hz	250
FLG	Gain	<u>100 %</u>	20 %	255
STA	Stability	<u>1 %</u>	20 %	257
ITH	Motor Thermal Current	<u>3,5 A</u>	3,6 A	258
IDC	DC Injection Current	2,5 A	2,5 A	270
TDC	DC Injection time	<u>0,2 s</u>	0,5 s	271
JPF	Jump frequency	0,0 Hz	0,0 Hz	286
TLS	Low Speed run time	0,0 s	0,0 s	272
UFR	IR Compensation	<u>50 %</u>	100 %	254
SLP	Slip Compensation	<u>1 %</u>	100 %	259
PFL	V/f Profile	100 %	100 %	256
JOG	JOG Frequency	10,0 Hz	10,0 Hz	262
JGT	JOG Delay	0,5 s	0,5 s	263
SP2	Preset speed 2	10,0 Hz	10,0 Hz	264
SP3	Preset speed 3	15,0 Hz	15,0 Hz	265
SP4	Preset speed 4	20,0 Hz	20,0 Hz	266
SP5	Preset speed 5	25,0 Hz	25,0 Hz	267
SP6	Preset speed 6	30,0 Hz	30,0 Hz	268
SP7	Preset speed 7	35,0 Hz	35,0 Hz	269
BRL	Brake release frequency	0,0 Hz	0,0 Hz	273
IBR	Brake Release current	0,0 A	0,0 A	277
BRT	Brake Release time	0,00 s	0,00 s	275
BEN	Brake engage Frequency	0,0 Hz	0,0 Hz	274
BET	Brake Engage Time	0,00 s	0,00 s	276
RPG	Proportional gain	1,00	1,00	279
RIG	Integral gain	1,00 /s	1,00 /s	280
FBS	Feedback Scale	1,0	1,0	281
CTD	Current Detection	5,5 A	5,5 A	282
FTD	Frequency Detection	50,0 Hz	50,0 Hz	284
TTD	Motor Thermal State Detection	100 %	100 %	283
TL2	Second Torque limit	200 %	200 %	278
DTS	Feedback Scale	1,00	1,00	285
	Entraînement			
UNS	Nominal Voltage	230 V	230 V	55
FRS	Nominal Frequency	<u>86,0 Hz</u>	50,0 Hz	53
NCR	Nominal Current	<u>3,7 A</u>	3,5 A	54
NSP	Nominal Speed	<u>2386 RPM</u>	1400 RPM	56
COS	Power Factor	<u>0,70</u>	0,77	57
TUN	Auto Tune	No	No	59
TFR	Maximum Output Frequency	<u>130,0 Hz</u>	60,0 Hz	52
NLD	Energy Savings	No	No	61
BRA	Decel. Ramp Adaptation	<u>Yes</u>	No	64
FRT	Switch to Ramp 2 Frequency	0,0 Hz	0,0 Hz	65
RPT	Type of Ramp	LIN:Linear ramp	LIN:Linear ramp	62

Télemécanique ATV 58 speed driver

Code	Label	Value	Default value	Logic address
DCF	Decel. Ramp Reduction Coefficient	4	4	63
TLI	Torque Limit	200 %	200 %	58
CLI	Courant de limitation interne	5,5 A	5,5 A	72
ADC	Automatic DC Injection	Yes	Yes	67
PCC	Motor Power Coefficient	1,0	1,0	69
SFT	Switching Frequency type	LF :Low Freq.	LF :Low Freq.	50
SFR	Switching Frequency	4 kHz	4 kHz	51
NRD	Motor Noise Reduction	Yes	Yes	60
SPC	Moteur spéciaux	No	No	70
PLS	PG pulse per revolution	1	1	68
PGT	Type de capteur GI	DET:Detector	DET:Detector	71
	Command			
TCC	Terminal Strip Configuration	2W :2 wire cntrl	2W :2 wire cntrl	6
TCT	Type of 2 wire	LEL:2 wire	LEL:2 wire	7
CRL	AI2 Min. Reference	4,0 mA	4,0 mA	4
CRH	AI2 Max. Reference	20,0 mA	20,0 mA	5
STR	Stored Frequency Reference	NO :no Save	NO :no Save	9
PST	STOP Key Priority	Yes	Yes	8
ADD	Drive Address	0	0	10
	I/O Assignments			
LI1	LI1 Assignment	FW :Forward	FW :Forward	100
LI2	LI2 Assignment	RV :Reverse	RV :Reverse	101
LI3	LI3 Assignment	<u>RST:Fault Reset</u>	PS2:2 preset SP	102
LI4	LI4 Assignment	<u>NO :Not assigned</u>	PS4:4 preset SP	103
LI5	LI5 Assignment	NO :Not assigned	NO :Not assigned	104
LI6	LI6 Assignment	NO :Not assigned	NO :Not assigned	105
AI1	AI1 Assignment	FRH:Freq. Ref.	FRH:Freq. Ref.	106
AI2	AI2 Assignment	SAI:Summed Ref.	SAI:Summed Ref.	107
AI3	AI3 Assignment	NO :Not assigned	NO :Not assigned	108
R1	R1 Assignment	FLT:VarFault	FLT:VarFault	109
R2	R2 Assignment	<u>RUN:DriveRunning</u>	OCC:Output Cont.	110
LO	LO Assignment	NO :Not assigned	NO :Not assigned	111
AO	AO Assignment	NO :Not Assigned	NO :Not Assigned	112
	Défauts			
ATR	Automatic Restart	No	No	150
RST	Fault Reset Type	RSP:Part. Reset	RSP:Part. Reset	158
OPL	Output Phse Loss	Yes	Yes	151
IPL	Input Phase Loss	No	No	152
THT	Type of Protection	ACL:Vent. Motor	ACL:Vent. Motor	153
LFL	Loss of Follower	No	No	154
FLR	Catch on fly	No	No	155
STP	Controlled Stop on power loss	NO	NO	156
SDD	Ramp not Followed	No	No	157
	Communication			
ADRC	Drive Address	0	0	200
PRO	Protocol	Not configured	Not configured	201
BDR	Transmission Speed	Not configured	Not configured	202
FOR	Format	Not configured	Not configured	203
TLP	Time out	1,0 s	1,0 s	204
PRC	PeerCop...	No	No	205
GLB	Global Tx	0	0	206
CDN	Command Node	0	0	207

Code	Label	Value	Default value	Logic address
	Specific card			
O01	Parameter N°1	0	0	350
O02	Parameter N°2	0	0	351
O03	Parameter N°3	0	0	352
O04	Parameter N°4	0	0	353
O05	Parameter N°5	0	0	354
O06	Parameter N°6	0	0	355
O07	Parameter N°7	0	0	356
O08	Parameter N°8	0	0	357
O09	Parameter N°9	0	0	358
O10	Parameter N°10	0	0	359
O11	Parameter N°11	0	0	360
O12	Parameter N°12	0	0	361
O13	Parameter N°13	0	0	362
O14	Parameter N°14	0	0	363
O15	Parameter N°15	0	0	364
O16	Parameter N°16	0	0	365
O17	Parameter N°17	0	0	366
O18	Parameter N°18	0	0	367
O19	Parameter N°19	0	0	368
O20	Parameter N°20	0	0	369
	Identification variateur			
	Drive catalog number	ATV58*U18M2		
	Drive catalog number	0.75kW 1HP		552
	Input Voltage	200/240V		553
	50/60 Hz Switch position	Produit 50Hz		554
	Rated continuous current	4,1 A		555
	Rated continuous current	12,5 A		
	Numéro de l'option connectée sur l	Pas de dialogue		1006

The Sepro configuration requires specific values in the “advanced drive” menu. This menu is only accessible if the Sepro password has been entered.

- ▶ Ent 0 : not used value : 0
- ▶ Ent 1 : different functions encoded in each bit
Removal of slipping deflection and compensation value : 2
- ▶ Ent 2 : not used value : 0
- ▶ Ent 3 : overfluxing rate in hexadecimal (60% for Sepro) value : 3C
overfluxing consists of injecting the recovered energy back into the motor.
- ▶ Ent 4 : ramp rounding coefficient (not used by Sepro) value : 0
- ▶ Ent 5 : Boost (not used by Sepro) value : 0
- ▶ Ent 6 : Filtering on speed regulating loop (not used by Sepro) value : 0
- ▶ Ent 7 : not used value : 0
- ▶ Ent 8 : not used value : 0
- ▶ Ent 9 : Must not be changed value FFFF

VI – TROUBLESHOOTING

Fault displayed	Probable cause	Procedure, remedy
PHF Mains Phase Loss	<ul style="list-style-type: none"> - speed controller incorrectly supplied or fuses blown - transient fault on one phase 	<ul style="list-style-type: none"> - check the power connection and the fuses - reset
USF Undervoltage	<ul style="list-style-type: none"> - line supply too low - transient voltage dip - damaged load resistor 	<ul style="list-style-type: none"> - check the line voltage - change the load resistor
OSF Overvoltage	<ul style="list-style-type: none"> - line supply too high 	<ul style="list-style-type: none"> - check the line voltage
DHF Drive Overheat	<ul style="list-style-type: none"> - heatsink temperature too high 	<ul style="list-style-type: none"> - monitor the motor load, the speed controller ventilation and wait for it to cool down before resetting
DLF Mot Overload	<ul style="list-style-type: none"> - thermal trip due to prolonged overload 	<ul style="list-style-type: none"> - check the thermal protection setting, monitor the motor load - a reset will be possible after approximately 7 minutes
DBF Overbraking	<ul style="list-style-type: none"> - braking too sudden or driving load 	<ul style="list-style-type: none"> - increase the deceleration time, add a braking resistor if necessary
DPF Motor Phase Loss	<ul style="list-style-type: none"> - one phase cut at the speed controller output 	<ul style="list-style-type: none"> - check the motor connections
LOF Loss Follower	<ul style="list-style-type: none"> - loss of the 4-20mA setpoint on input AI2 	<ul style="list-style-type: none"> - check the connection of the setpoint circuits
OCF Overcurrent	<ul style="list-style-type: none"> - ramp too short - inertia or load too high - mechanical locking 	<ul style="list-style-type: none"> - check the settings - check the size of the motor/speed controller/load - check the state of the mechanism
SCF Short Circuit	<ul style="list-style-type: none"> - short-circuit or grounding at the speed controller output 	<ul style="list-style-type: none"> - check the connection cables with the speed controller disconnected, and the motor insulation. Check the speed controller transistor bridge
CRF Precharge Fault	<ul style="list-style-type: none"> - load relay control fault - damaged load resistor 	<ul style="list-style-type: none"> - check the connectors in the speed controller and the load resistor
SLF Serial Link Flt	<ul style="list-style-type: none"> - incorrect connection on the speed controller terminal port 	<ul style="list-style-type: none"> - check the connection on the speed controller terminal port
MOF Motor Overheat	<ul style="list-style-type: none"> - motor temperature too high (PTC probes) 	<ul style="list-style-type: none"> - check the motor ventilation and the ambient temperature, monitor the motor load - check the type of probes used
ESF PTC Therm Sensor	<ul style="list-style-type: none"> - incorrect connection of probes to the speed controller 	<ul style="list-style-type: none"> - check the connection of the probes to the speed controller - check the probes

Fault displayed	Probable cause	Procedure, remedy
EEF EEPROM Fault	- error saving in EEPROM	- cut the power supply to the speed controller and reset
Inf Internal Fault	- internal fault - connector fault	- check the connectors in the speed controller
EPF External Fault	- fault triggered by an external device	- check the device which has caused the fault and reset
SPF Sp. Feedbk. Loss	- no speed feedback	- check the connection and the mechanical coupling of the speed sensor
RnF Load User. Flt	- non-following of ramp - speed inverse to the setpoint	- check the speed feedback setting and wiring - check the suitability of the settings for the load - check the size of the motor - speed controller and the possible need for a braking resistor
SDF OverSpeed	- instability - driving load too high	- check the settings and the parameters - add a braking resistor - check the size of the motor/speed controller/load
CnF Network Fault	- communication fault on the fieldbus	- check the network connection to the speed controller - check the time-out
ILF Int. Comm. Flt	- communication fault between the option card and the control card	- check the connection of the option card to the control card
CFE Rating Fault-ENT Option Fault-ENT Opt. Missing-ENT CKS Fault - ENT	Error probably caused when changing the card : - change of rating of the power card - change of the type of option card or installation of an option card if there was not one already and if the macro-configuration is CUS - option card removed - inconsistent configuration saved The following message appears when ENT is pressed : Fact.Set? ENT/ESC	- check the hardware configuration of the speed controller (power card, others) - cut the power supply to the speed controller then reset - save the configuration in a file on the display module - press ENT to return to the factory settings
CFI Config. Fault	- inconsistent configuration sent to speed controller via serial link	- check the configuration sent previously - send a consistent configuration

Conair has made the largest investment in customer support in the plastics industry. Our service experts are available to help with any problem you might have installing and operating your equipment. Your Conair sales representative also can help analyze the nature of your problem, assuring that it did not result from misapplication or improper use.

WE'RE HERE TO HELP

To contact Customer Service personnel, call:



HOW TO CONTACT CUSTOMER SERVICE

From outside the United States, call: 814-437-6861

You can commission Conair service personnel to provide on-site service by contacting the Customer Service Department. Standard rates include an on-site hourly rate, with a one-day minimum plus expenses.

If you do have a problem, please complete the following checklist before calling Conair:

- Make sure you have all model, serial and parts list numbers for your particular equipment. Service personnel will need this information to assist you.
- Make sure power is supplied to the equipment.
- Make sure that all connectors and wires within and between loading control and related components have been installed correctly.
- Check the troubleshooting guide of this manual for a solution.
- Thoroughly examine the instruction manual(s) for associated equipment, especially controls. Each manual may have its own troubleshooting guide to help you.
- Check that the equipment has been operated as described in this manual.
- Check accompanying schematic drawings for information on special considerations.

BEFORE YOU CALL ...

Additional manuals and prints for your Conair equipment may be ordered through the Customer Service or Parts Departments for a nominal fee.

EQUIPMENT GUARANTEE

Conair guarantees the machinery and equipment on this order, for a period as defined in the quotation from date of shipment, against defects in material and workmanship under the normal use and service for which it was recommended (except for parts that are typically replaced after normal usage, such as filters, liner plates, etc.). Conair's guarantee is limited to replacing, at our option, the part or parts determined by us to be defective after examination. The customer assumes the cost of transportation of the part or parts to and from the factory.

PERFORMANCE WARRANTY

Conair warrants that this equipment will perform at or above the ratings stated in specific quotations covering the equipment or as detailed in engineering specifications, provided the equipment is applied, installed, operated and maintained in the recommended manner as outlined in our quotation or specifications.

Should performance not meet warranted levels, Conair at its discretion will exercise one of the following options:

- Inspect the equipment and perform alterations or adjustments to satisfy performance claims. (Charges for such inspections and corrections will be waived unless failure to meet warranty is due to misapplication, improper installation, poor maintenance practices or improper operation.)
- Replace the original equipment with other Conair equipment that will meet original performance claims at no extra cost to the customer.
- Refund the invoiced cost to the customer. Credit is subject to prior notice by the customer at which time a Return Goods Authorization Number (RGA) will be issued by Conair's Service Department. Returned equipment must be well crated and in proper operating condition, including all parts. Returns must be prepaid.

Purchaser must notify Conair in writing of any claim and provide a customer receipt and other evidence that a claim is being made.

WARRANTY LIMITATIONS

Except for the Equipment Guarantee and Performance Warranty stated above, Conair disclaims all other warranties with respect to the equipment, express or implied, arising by operation of law, course of dealing, usage of trade or otherwise, including but not limited to the implied warranties of merchantability and fitness for a particular purpose.