

USER GUIDE
UGG012/1003

CM granulator

Models 1010, 1014, and 1018



INSTALLATION • Lifting the machine during installation • Installation • Electrical connection • Check the direction of rotation of the granulator motor • If the direction of rotation of the granulator motor is incorrect • **OPERATION** • Function description • Safety system • Safety switches • Star knobs • Emergency stop • Before starting, ensure that • The key for the electrical cabinet door • Starting and stopping • Start • Stop • **MAINTENANCE AND SERVICE** • Inspection • Daily inspection • Weekly inspection • Every 6 months or 4000 running hours • Check annually or 8000 running • Opening of hopper, granule bin and cutter housing • Open the hopper • Open the granule bin • Open the cutter housing • Closing of cutter housing, granule bin and hopper • Close the cutter housing

Please record your equipment's model and serial number(s) and the date you received it in the spaces provided.

It's a good idea to record the model and serial number(s) of your equipment and the date you received it in the User Guide. Our service department uses this information, along with the manual number, to provide help for the specific equipment you installed.

Please keep this User Guide and all manuals, engineering prints and parts lists together for documentation of your equipment.

Date:

Manual Number: UGG012/1003

Serial Number(s):

Model Number(s):

DISCLAIMER: The Conair Group, Inc., shall not be liable for errors contained in this User Guide or for incidental, consequential damages in connection with the furnishing, performance or use of this information. Conair makes no warranty of any kind with regard to this information, including, but not limited to the implied warranties of merchantability and fitness for a particular purpose.

Table of Contents

1. Safety

Danger occurs.	1-2
Note	1-3

2. Introduction

Introduction	2-2
Summary.	2-3

3. Installation

3.1 Lifting the machine during installation.	3-2
3.2 Installation	3-5
– Eight hours or one day after first start	
3.3 Electrical connection	3-5
– Check the direction of rotation of the granulator motor . . .	3-5
– If the direction of rotation of the granulator motor is incorrect	3-6

4. Operation

4.1 Function description	4-2
4.2 Safety system	4-4
– Safety switches	4-5
– Star knobs	4-6
– Emergency stop	4-7
– Before starting, ensure that	4-7
– The key for the electrical cabinet door	4-7

4.3 Starting and stopping	4-8
– Start	4-8
– Stop	4-8

5. Maintenance and service

5.1 Inspection	5-2
– Daily inspection	5-2
– Weekly inspection	5-2
– Every 6 months or 4000 running hours	5-3
– Check annually or 8000 running hours	5-3
5.2 Opening of hopper, granule bin and cutter housing	5-4
– Open the hopper	5-4
– Open the granule bin	5-5
– Open the cutter housing	5-5
5.3 Closing of cutter housing, granule bin and hopper	5-6
– Close the cutter housing	5-6
– Install the granule bin	5-6
– Close the hopper	5-6
5.4 Cleaning	5-7
5.5 Changing of fixed knives, rotating segments and feed hook	5-8
To change the cutting parts	5-8
– Removal of fixed knives	5-8
– Removal of rotating segments and feed hook	5-9
– First install the rotating segments and feed hook	5-12
– Then install the fixed knives	5-14
5.6 Grinding of cutting parts	5-16
– Grinding fixed knives	5-16
– Grinding rotating segments and feed hook	5-17

5.7	Transmission	5-19
	– Reduction gear	5-19
	– Check the drive belt condition	5-20
5.8	Lubrication	5-21
	– Granulator	5-21
6.	Options	
6.1	Automatic reversing system	6-2
	– Function	6-3
	– Program relay	6-3
6.2	Level monitor	6-5
	– Setting the paddle monitor sensitivity	6-6
6.3	Hours counter	6-7
7.	Electricity	
	Electricity	7-2
8.	Troubleshooting	
	Troubleshooting	8-2
	– If the granulator does not start	8-2
	– Check the granulator options	8-3
	– If the granulator does not start after normal Troubleshooting	8-4
9.	Spare parts list	
	– Ordering spare parts	9-2
9.1	Cutter Housing	9-3
9.2	Fixed Knives and Cutting Parts	9-4
9.3	Hopper, Flaps, Feed Components	9-5
9.4	Transmission	9-6
9.5	Granule Bin	9-7
9.6	Stand	9-8
9.7	Paddle monitor	9-9

10.	Layout	
	CM Granulator	10-2
11.	Transport and storage	
	11.1 General	11-2
	11.2 Transport	11-2
	11.3 Storage	11-5
12.	Technical Specifications	
	Cutter housing	12-2
	Motor	12-2
	Cutting parts and fixed knives	12-2
	Knife clearance	12-2
	Granule bin	12-3
	Transmission	12-3
	Sound level	12-3
	Weight	12-3
	Maintenance schedule	12-4
	Machine data	12-4
	Installation	12-4
	Safety, maintenance and service	12-4
	Inspection	12-5
	Daily inspection	12-5
	Weekly inspection	12-5
	Every 6 months or 4000 running hours	12-9
	Check annually or 8000 running hours	12-11
	Changing of cutting parts	12-12
	Malfunctions	12-13
	Notes	12-14

A. Appendix

We're Here to Help	A-1
How to Contact Customer Service	A-1
Before You Call...	A-1
Equipment Guarantee	A-2
Performance Warranty	A-2
Warranty Limitations	A-2

Safety

Danger occurs 1-2
Note 1-3

Conair granulators are designed to granulate injection molded plastics waste.

The granulators have a safety system, which is described in chapter 4.2.



WARNING!

Risk of cutting or pinch injury!

This sign is located where there is a risk of cutting or pinch injury.



NOTE!

This sign is located where special attention is necessary.



WARNING!

Hazardous voltage!

This sign is located on the door of the electrical cabinet and any junction boxes.

Danger occurs:



- **The machine contains rotating segment and feed hook. They are sharp and can cause personal damage even when they are not rotating.**



- **The granulator must not be used without the granule bin. The granule bin is part of the safety devices on the granulator. The granule bin must always be installed during operation.**



- **The granulator must not be started without the hopper funnel. If the hopper funnel is not installed, the cutter is accessible through the hopper opening and can cause personal injury.**



- **There is a pinch risk when the hopper and cutter housing upper part are opened and closed. Be careful.**



- **The electrical cabinet of the machine contains hazardous high voltage, contact can be fatal.**

NOTE



- **Electrical installation must only be done by a suitably qualified electrician.**



- **Before the granulator is opened for service or maintenance. Stop the granulator! Turn the main switch to the “0” position (Off) and remove the granulator’s plug from the main socket.**



- **Never insert any part of your body into openings in the granulator, unless main switch is in the “0” position (Off) and the granulator’s plug has been pulled out from the main socket.**



- **If the cutter has to be turned to neutral, take great care when you do this!**



- **It should not be possible to start the granulator until the hopper and granule bin are securely shut.**



- **The granulator must never be started if the electrical cabinet or transmission doors are open.**



- **The electrical cabinet and transmission doors should always be securely installed, closed and locked when the granulator is in operation!**



- **The key for the electrical cabinet door is a safety component. The key must be kept by the person who is responsible for the granulator safety, service and maintenance.**



- **The electrical cabinet and transmission doors must never be opened when the granulator is in operation.**



- **Never remove protective gratings or pipes adjacent to the out feed or granule bin.**



- **Use protective goggles when cleaning the granulator!**



- **Use protective gloves when changing the cutting parts!**

Introduction

Introduction	2-2
Summary	2-3

This manual applies to Conair CM granulators.

Model nos. 1010, 1014 and 1018 refer to the size of the cutter housing.



Read the manual before installation and use of the machine!



Be careful when the cutting parts are accessible. They are sharp and can cause personal injury!

This Conair granulator is designed for granulating injection molded plastics waste.

Granulator size and performance are chosen to suit the type of waste.

If other products or material are granulated, approval must be obtained from Conair beforehand for the warranty conditions to apply.

The granulator is designed to permit rapid and simple maintenance and cleaning, for both routine maintenance and material changes.

All service work must be done by trained service personnel.

This manual contains instructions for both operation and service.

Chapter 5 contains instructions directed towards service personnel.

Chapter 6 contains instructions for the accessory equipment of the machine.

Other chapters contain instructions for the operator.

Any modification and alterations to the granulator must be approved by Conair.

This is in order to prevent personal injury and product damage, the machine warranty to apply and for product liability reasons.

If you have any questions, please contact the local Conair distributor or the Conair head office.

Head office:

Conair

One Conair Drive

Pittsburgh, PA 15202

Phone: 412-312-6000

Fax: 412-312-6227

We reserve the right to make continuous design and material changes
and to amend specifications without prior notice.

Summary

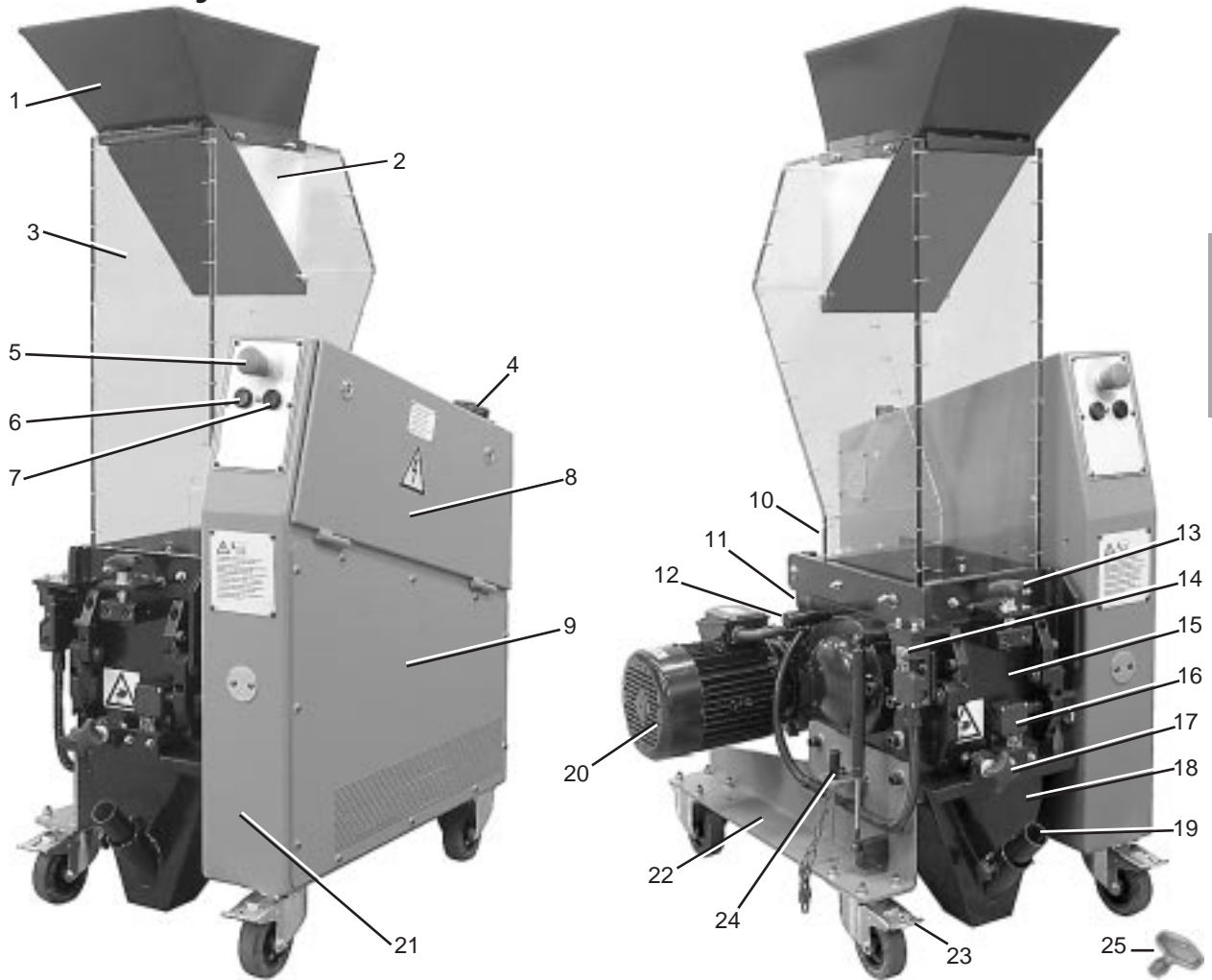

- 1. Hopper funnel
- 2. Flap in hopper opening
- 3. Hopper
- 4. Main switch
- 5. Emergency stop
- 6. Start button
- 7. Stop button
- 8. Electrical cabinet
- 9. Transmission
- 10. Support, hopper
- 11. Reduction gear
- 12. Handle, upper part cutter housing

- 13. Star knob, hopper
- 14. Safety switch, hopper
- 15. Cutter housing
- 16. Safety switch, granule bin
- 17. Star knob, granule bin
- 18. Granule bin
- 19. Suction pipe, out feed
- 20. Motor
- 21. Stand
- 22. Support, stand
- 23. Brake arm, wheel
- 24. Tool, cutter
- 25. Key, electrical cabinet

Installation

- 3.1 Lifting the machine during installation . . . 3-2
- 3.2 Installation 3-5
 - Eight hours or one day after first start . 3-5
- 3.3 Electrical connection 3-5
 - Check the direction of rotation of the granulator motor 3-5
 - If the direction of rotation of the granulator motor is incorrect. 3-6

Please read all of chapter 3 before installing the machine.

All instructions must be followed in sequence to avoid damage.

3.1 Lifting the Machine During Installation

The machine must be transported by trained personnel.

The machine is supplied packed in protective plastic foil, locked to a transport pallet with screws and PET straps.

Removing packaging and goods arrival inspection

- **Check that the machine has not been damaged in transport.**



NOTE! Any damage must be reported to the goods forwarding agency.

- Do not remove the packaging from the machine until it has been transported to the place where it will be installed.
- Check the dispatch note to see that the shipment is complete.

Lifting and transporting the machine to the place where it will be installed.

The machine weighs about 335 - 385 kg, including packaging.

The space needed is noted in Layout, chapter 10.

The machine can be lifted and handled by means of a fork-lift truck or a traversing crane.

With a fork-lift truck

The machine can be lifted and handled by means of a fork-lift truck .

- 1** Set the fork width on fork-lift truck to 400 mm.
- 2** Remove the granule bin.
- 3** Drive in the fork-lift truck and make sure that the lifting forks balance the granulator, then lift the machine.

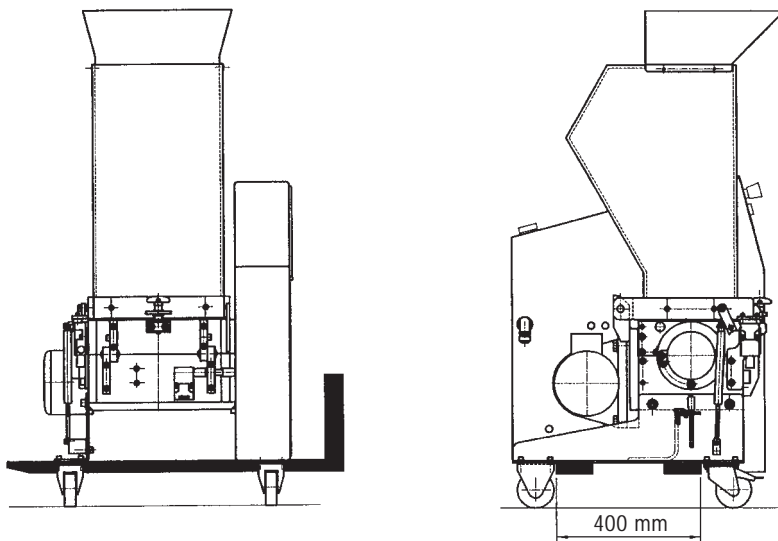

With traversing crane and a lifting strop

The machine can be lifted by means of a double strop and a lifting yoke. The length of the strop should be at least 5 metre (10.0 m circumference).

- 1 Remove the granule bin.
- 2 Install the lifting strop underneath the granulator stand.
- 3 Then install a lifting yoke.

Use a traversing crane or a fork-lift truck and then lift the machine as shown in the illustrations.

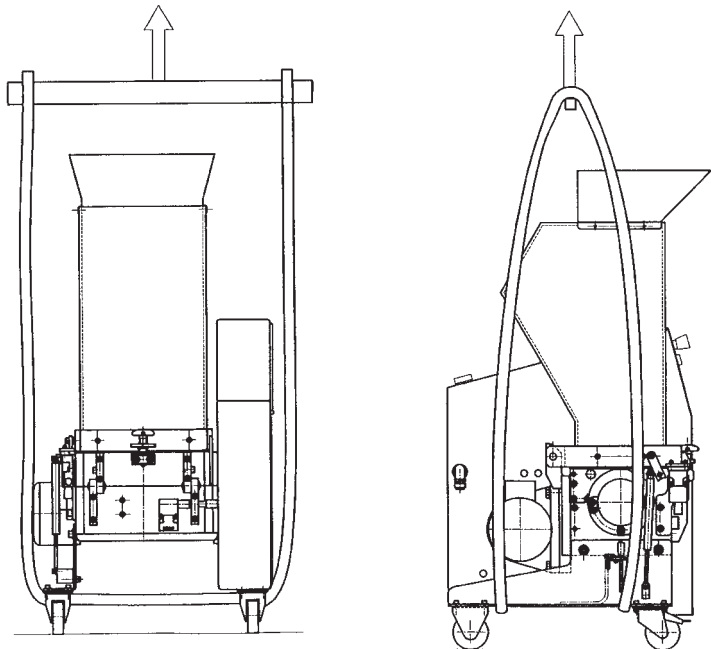

3.2 Installation

NOTE! The key for the electrical cabinet is a safety component. The key must be kept by the person who is responsible for granulator safety, service and maintenance.

- Put the granulator in place and ensure that it is horizontal and stable on the ground.
- The unpainted components of the machine are coated with rust preventer for protection before transport and delivery.
Clean the granulator from rust protection agent before it is used.
- Lock the wheels, tread the wheel brake catches down.

Eight hours or one day after first start

Check the knife clearance and tightening torque of the fixed knives retaining screws. Read chapter 5.5 in this manual.

3.3 Electrical Connection

Connection to the main must only be done by a suitably qualified electrician.

- Connect the granulator to the main. The system voltage (Volt) and fuse size (Amp) of the machine is noted in the wiring diagram.
- Check the phase sequence of the main with a phase sequence indicator and connect the granulator to the main with a main plug.

Check the direction of rotation of the granulator motor

- Check that the hopper and granule bin are securely shut. The star knobs on the hopper and the granule bin must be securely screwed in.
- Check that the granulator is steady on the ground, lock the wheels, tread the wheel brake catches down.
- Connect the main plug to the main outlet.
- Turn the main switch to position “1” (On)
- Start the granulator, press the “Start” button.
- Check that the direction of rotation of the granulator motor coincides with the arrow on the motor housing.

TIP: Start the motor and stop it again at once.

Before the motor has had time to stop completely – carefully insert a cable tie into the rear of the motor housing and carefully feel the direction of rotation of the motor.

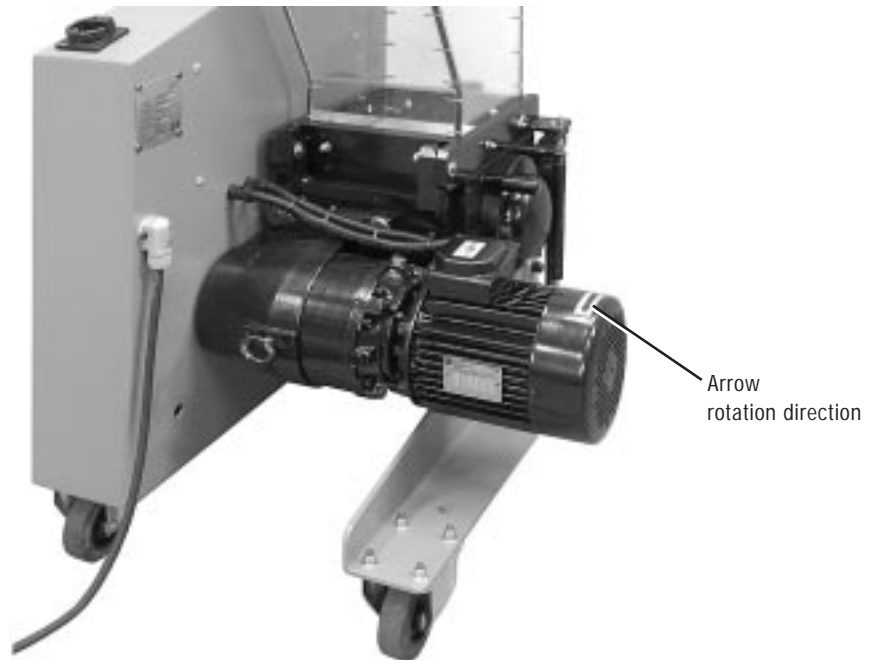

If the direction of rotation of the granulator motor is incorrect:

- Stop the granulator, press the “Stop” button.
- Turn the main switch to position “0” (Off) and pull the main plug out of the main outlet.
- Transpose two of the incoming phases in the main plug.

NOTE: Sign the instruction manual, chapter 12, when the installation is completed.

Operation

4.1 Function description	4-2
4.2 Safety system	4-4
– Safety switches	4-5
– Star Knobs	4-6
– Emergency stop	4-7
– Before starting, ensure that	4-7
– The key for the electrical cabinet door .	4-7
4.3 Starting and stopping	4-8
– Start	4-8
– Stop	4-8

4.1 Function Description

The granulator is designed for cutting up plastics waste to granulate, for re-use.

The plastics waste must be free from metal objects and contamination before granulation.

The granulator is started and stopped with the press buttons on the control panel.

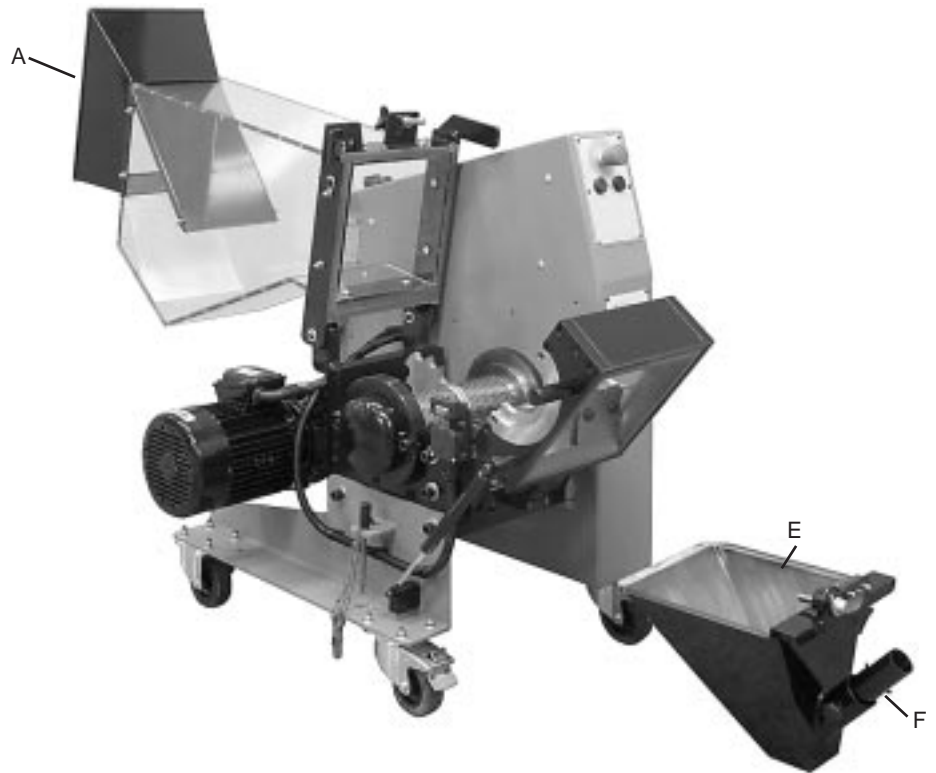

The plastics waste is put into hopper "A" and falls down into the cutter housing, where the feed hook "B" and rotating segments "C" cut the plastic into pieces, against fixed knives "D", to form granulate.

The granulate falls down to the granule bin "E", which collects the finished granulate.

The granule bin can be emptied with vacuum suction through the out feed pipe "F".

The finished granulate can be used at once in the production machinery. The granulate can also be transported to a collection bin for later use.

The granule bin can be easily removed and the hopper can be opened to give improved access during cleaning and maintenance.

All fixed knives and cutting parts in the granulator can be re-sharpened.

The fixed knives can easily be removed, sharpened and reinstalled.

To sharpen the rotating breaker knives we recommend sending them to Conair.

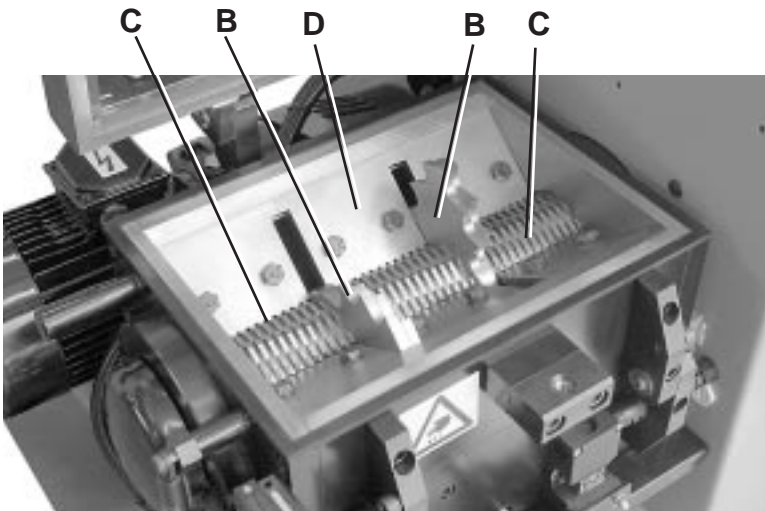

4.2 Safety System

The granulator has a safety system which is intended to prevent access to dangerous components during operation.

Rotating breaker knives rotate with high power inside the granulator. For this reason, the granulator is provided with safety switches and an emergency stop to prevent personal injury.

The hopper, hopper funnel and granule bin are components which are included in the granulator safety system.

NOTE! These components must always be securely fastened before the granulator can be started.

The safety system must not be changed or modified under any circumstances.

If the safety system is changed or modified in any way, it can be dangerous to use and could cause serious personal injury.

All maintenance and service which relates to the safety systems of the granulator must be carried out with personnel who have the necessary training and knowledge.

If the safety system is changed or modified in any way, Conair's product responsibility under the Machinery Directive ceases to apply.

No component in the safety system may be replaced by anything other than spare parts provided by Conair.



Safety Switches

The safety switches consist of a star knob with long screw and a position switch with circuit breaking key.

The safety switches cut the current so that the granulator can not be started when any hazardous section of the granulator is accessible.

This granulator has 2 safety switches:

1 by the hopper (between the hopper and the cutter housing).

1 by the granule bin (between the granule bin and the cutter housing).

When the hopper and granule bin have been opened, it should not be possible to start the granulator.

When the star knob on the hopper or granule bin has been opened, the circuit breaking key position is changed. The position switch then cuts the current and the granulator stops.

The screw on the star knob is long. It should take such a long time to undo a star knob that the granulator has time to stop before any hazardous component of the granulator becomes accessible.

NOTE! The granulator must never be routinely stopped by using the safety switches. Stop the granulator with the stop button. Turn the main switch in position "0" (Off) and pull the main plug out of the main outlet before doing any cleaning, maintenance or service.



Star knobs

The star knobs on the hopper and granule bin are important components in the granulator safety systems. The length of the screw is selected so as to give the granulator time to stop before the star knob is fully undone and the knives become accessible. On this granulator, the star knobs should have screws which are 40 mm long. When safety components are changed, only spare parts supplied by Conair may be used. Star knobs with worn threads may only be replaced by new ones supplied by Conair. Please refer to chapter 9 for spare parts.



NOTE: When a star knob is installed, there should be a clearance between flange, knob and bracket.

Checking the safety switches

NOTE: Be careful!

- 1** Screw in the star knobs on the hopper and granule bin firmly until they bottom.
- 2** Connect the main plug to the main outlet.
- 3** Turn the main switch to position “1” (On).
- 4** Start the granulator, press the start button.
- 5** Undo, unscrew the star knob on the hopper. Check that the granulator stops (the safety switch cuts the current) before the star knob has been rotated 4 turns.
- 6** Undo, unscrew the star knob on the granule bin. Check that the granulator stops (the safety switch cuts the current) before the star knob has been rotated 4 turns.

If the granulator does not stop before the star knob has been rotated 4 turns (the safety switch does not cut the current). Stop the granulator with the stop button, put the main switch in position “0” (Off) and pull the main plug out of the main outlet.



Contact Conair – there is a severe risk of personal injury.

Emergency stop

This is the red button on the granulator control panel.

Press the button to stop the granulator quickly.

Re-set by turning the knob in the direction of the arrow (counter-clockwise).

The granulator might be equipped with more than one emergency stop.

Before starting, ensure that

- The hopper and granule bin must be securely closed. The star knobs on the hopper and granule bin must be fully screwed in.
- The electrical cabinet and transmission doors should always be securely installed, closed and locked!

Check the safety systems of the granulator regularly.

The key for the electrical cabinet door

NOTE: The key for the electrical cabinet is a safety component. The key must be kept by the person who is responsible for granulator safety, service and maintenance.

4.3 Starting and Stopping

Starting and stopping is controlled from the control panel.

Start

Before the granulator is started, ensure that:

- The hopper and granule bin must be securely closed. The star knobs on the hopper and granule bin must be fully screwed in.
- The electrical cabinet and transmission doors should always be securely installed, closed and locked!
- The granulator must be securely installed beside the injection molding machine, with the wheels locked.



Start the granulator

- 1 Connect the main plug to the main outlet.
- 2 Turn the main switch to position “1” (On).
- 3 Check that the emergency stop button is not depressed.
- 4 Press the start button.

Stop

Stop the granulator

- 1 Stop the granulator with the stop button.
- 2 Turn the main switch to position “0” (Off).
- 3 Press the emergency stop button.
- 4 Pull the main plug out of the main outlet.

Maintenance and Service

5.1 Inspection	5-2
– Daily inspection	5-2
– Weekly inspection	5-2
– Every 6 months or 4000 running hours	5-3
– Check annually or 8000 running hours	5-3
5.2 Opening of hopper, granule bin and cutter housing	5-4
– Open the hopper	5-4
– Open the granule bin	5-5
– Open the cutter housing	5-5
5.3 Closing of cutter housing, granule bin and hopper	5-6
– Close the cutter housing	5-6
– Install the granule bin	5-6
– Close the hopper	5-6
5.4 Cleaning	5-7
5.5 Changing of fixed knives, rotating segments and feed hook	5-8
– To change the cutting parts	5-8
– Removal of fixed knives	5-8
– Removal of rotating segments and feed hook	5-9
– First install the rotating segments and feed hook	5-12
– Then install the fixed knives	5-14
5.6 Grinding of cutting parts	5-16
– Grinding fixed knives	5-16
– Grinding rotating segments and feed hook	5-17
5.7 Transmission	5-19
– Reduction gear	5-19
– Check the drive belt condition	5-20
5.8 Lubrication	5-21
– Granulator	5-21

5.1 Inspection

There must not be any material residue left in the granulator during inspection.



NOTE: Checks every 6 months and annually must be done by trained personnel, to avoid personal injury and machinery damage.

Sign in this manual, chapter 12, when the check is completed.

Daily inspection

- Emergency stop. Check the emergency stop function. Start the granulator and then do an emergency stop with the emergency stop button. Re-set the emergency stop, turn the button in the direction of the arrow (counter-clockwise).
- Flap. Check that the flap in the hopper opening is intact. A damaged flap can allow material to be thrown back through the hopper opening. Change a damaged flap at once.

Emergency stop



Flap



Weekly inspection

- Cables. Check all cables on the machine. There must never be any damaged or loose cables. Only a qualified electrician should work on damaged or loose cables.
- Safety switch. Check the function of the safety system. Read chapter 4.2 “Safety system” in this manual. This granulator has 2 safety switches.
 - 1 by the hopper (between the hopper and the cutter housing)
 - 1 by the granule bin (between the granule bin and the cutter housing).



NOTE: Components and parts in the safety of the machine must only be replaced by spare parts supplied by Conair.

Every 6 months or 4000 running hours

- Check the wear on fixed knives, rotating segments and feed hook.
Grind the fixed knives, rotating segments and feed hook if they are worn, read chapter 5.6.
- Check the tightening torque of the fixed knives retaining screws, tightening torque 85 Nm.

Check annually or 8000 running hours

- Check the drive belt condition.
- Check the oil level in reduction gear, read chapter 5.7.
- Check the sealings to cutter housing bearings.
Change the sealings as necessary.

5.2 Opening of Hopper, Granule Bin and Cutter Housing

Stop the granulator with the stop button. Turn the main switch to position “0” (Off). Press the emergency stop button. Pull the main plug out of the main outlet.



Be careful when the hopper and granule bin are open!



The cutting parts are then accessible. They are sharp and can cause personal injury!



Pinch risk in the following tasks, be careful!

Undo the wheel brakes and move the granulator away.

NOTE: Make sure that the granulator has stopped before it is moved.

Open the hopper

- Undo the star knob “G” to the hopper “A”. The safety switch between hopper and cutter housing ensures that the granulator can not be started, when the hopper has been opened.
- Fold the hopper backwards. The hopper will stop against a stop heel in open position.

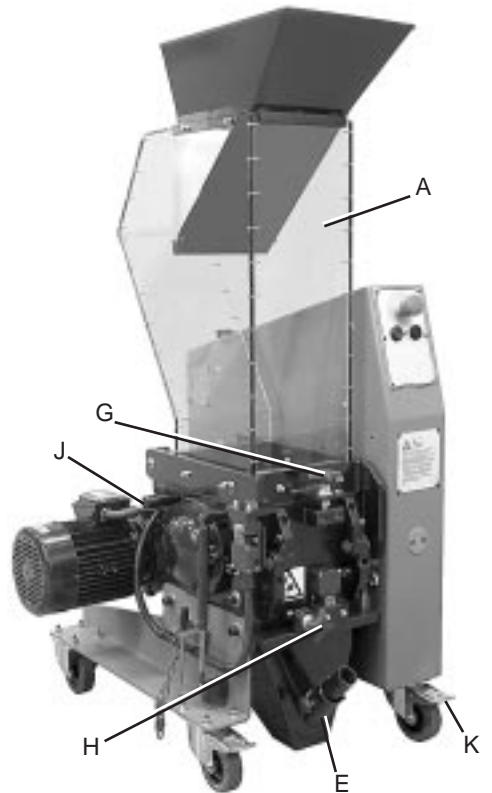

Open the granule bin

- Undo the star knob “H” on the granule bin “E”.
- Pull the handle and draw the granule bin “E” straight out.
The safety switch between granule bin and cutter housing ensures that the granulator can not be started, when the granule bin has been opened.

Open the cutter housing

- Grasp the handle ”J” and then lift the upper part of the cutter housing upwards and forwards.

NOTE: Be careful when the hopper, granule bin and cutter housing are opened! The cutting parts are then accessible, they are sharp and can cause personal injury!

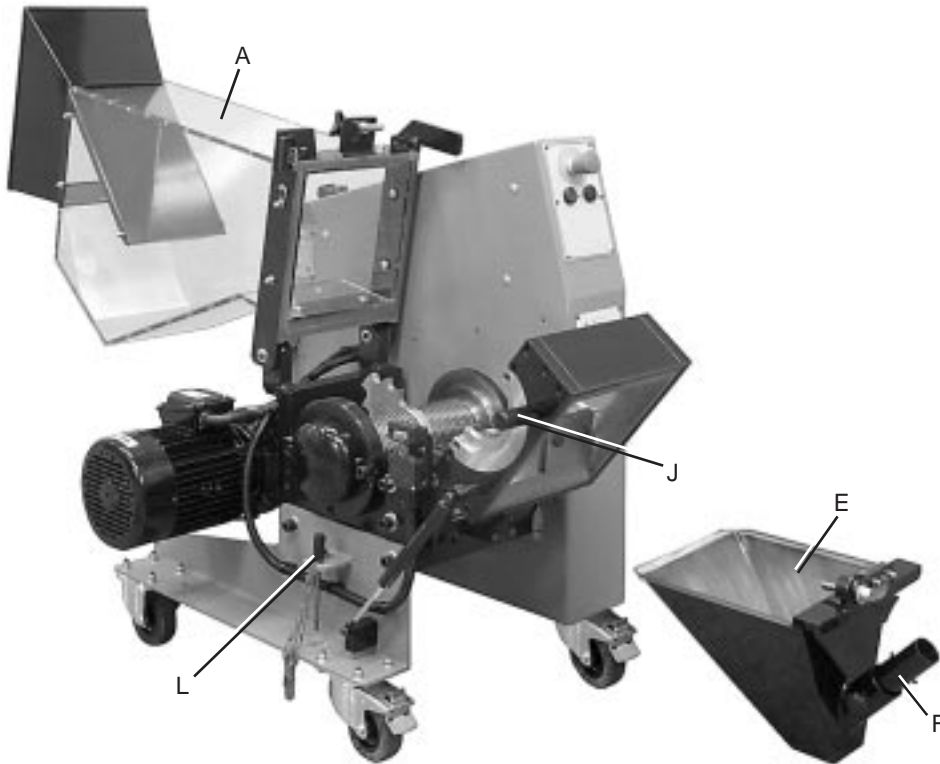

5.3 Closing of Cutter Housing, Granule Bin and Hopper

Refer to the labeled photographs on pages 5-4 and 5-5.



NOTE: Before closing, make sure that the mating surfaces are clean!

Close the cutter housing

- Grasp the handle “J” and then lift the upper part of the cutter housing backwards and down.

Install the granule bin

- Install the granule bin “E”.
Fit the granule bin into the grooves on the cutter housing and then slide the granule bin in until it stops.
- Fasten the granule bin, screw in the star knob “H” firmly until it bottoms.



NOTE: The granulator can not be started unless the granule bin is securely closed. The star knob must be screwed in firmly until it bottoms.

Close the hopper

Check and make sure that no granulate lies on the mating surfaces.

- Fold the hopper “A” upwards and forwards.
- Fasten the hopper, screw in the star knob “G” firmly until it bottoms and the hopper fits neatly against the cutter housing.



NOTE: The granulator can not be started unless the hopper is securely closed. The star knob must be screwed in firmly until it bottoms.

- Check that the granulator stands firmly. Lock the wheels, press the wheel brake arms “K” down.
- Connect the main plug to the main outlet.
- Turn the main switch to position “1” (On).
- Check that the emergency stop button is not depressed.
- Start the granulator, press the start button.

5.4 Cleaning

Clean the granulator at color changes or monthly.

1 Check that the hopper is empty, then stop the granulator with the stop button.

2 Open the hopper, granule bin and cutter housing, read chapter 5.2



Be careful when the hopper, granule bin and cutter housing has been opened! The knives are then accessible. They are sharp and can cause personal injury!

3 Use a vacuum cleaner during cleaning.

4 Clean the granule bin.

5 Clean the inside of the cutter housing. Clean properly under the fixed knives. The cutter can be rotated manually, use the tool “L”.

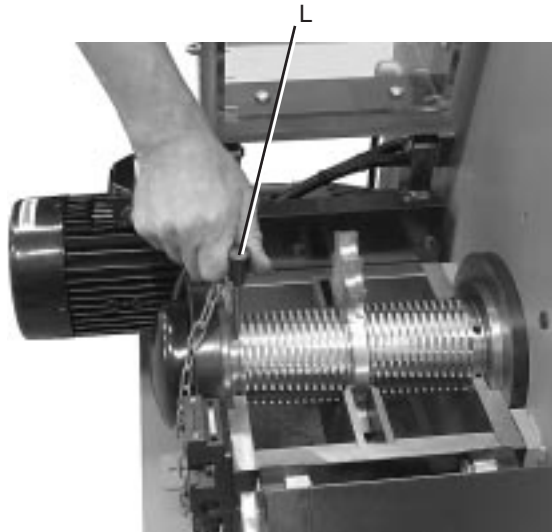

NOTE: When the cutter is rotated manually, do this with great care.



The knives are sharp and can cause personal injury.

6 Clean the polycarbonate hopper use only a soap water solution.



NOTE: A normal washing detergent solution can damage the polycarbonate hopper.

7 Close the cutter housing, granule bin and hopper, read chapter 5.3

8 Clean the granulator outside, use vacuum cleaner.

5.5 Changing of Fixed Knives, Rotating Segments and Feed Hook

Changing the cutting parts of granulator must be done by trained personnel, to avoid personal injury and machinery damage.



NOTE: Be careful when handling the cutting parts of granulator. They are sharp and can cause personal injury!



When the cutter is rotated manually, do this with great care.

To change cutting parts:

- 1 Check that the hopper is empty, then stop the granulator with the stop button.
- 2 Remove the granule bin and open the hopper, read chapter 5.2



Be careful when the hopper, granule bin and cutter housing has been opened! The cutting parts of granulator are then accessible, they are sharp and can cause personal injury!

Removal of fixed knives

- 1 Undo and remove the screws “M” and washers “N”.
- 2 Remove the fixed knives “D”.

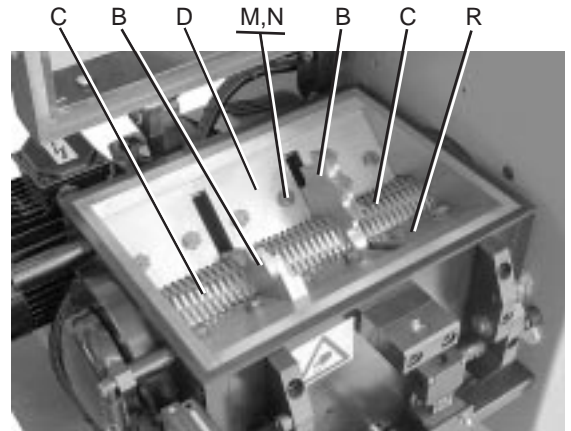

Removal of rotating segments and feed hook

Only qualified personnel should remove and install the rotating segments “C” and feed hook “B”.

- 1 Undo and remove the covering plate to transmission.

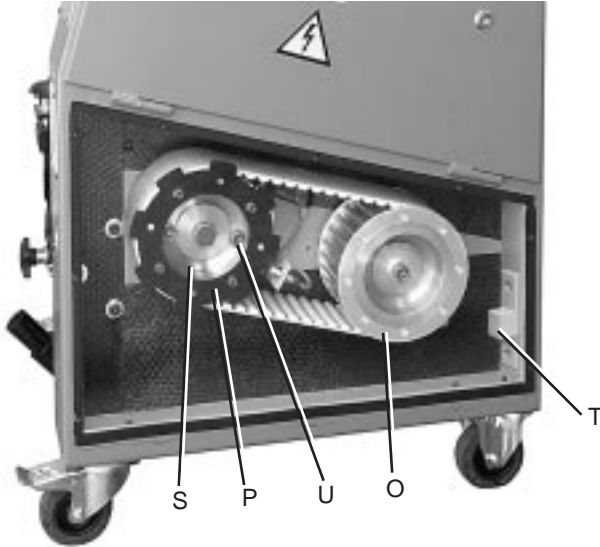

- 2 Undo and remove the support ring “O” from motor pulley.
- 3 Granulators with Automatic reversing system, undo and remove the indication ring “P” from cutter pulley.
- 4 Lock the feed hook against the scrapers “R” or against cutter housing with a piece of wood.
Undo and remove the screw and washer to the cutter shaft in the center of the cutter pulley.
- 5 Remove the cutter pulley “S”, use the remover “T”.
Undo and remove the 2 socket cap screws “U” in the center of cutter pulley.
Install the puller using the socket cap screws “U” and tighten, to release the cutter pulley.

6 Loosen the 4 hex head screws “V” which hold reduction gear and motor against cutter housing.

Loosen the screws 3 turns. **NOTE:** Don't remove the screws.

7 Remove the drive belt.

Turn motor and reduction gear backwards to decrease the drive belt tension, then the drive belt can be removed.

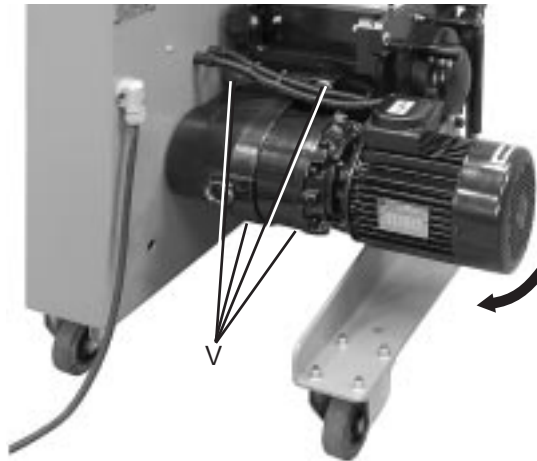

8 Undo and remove the bearing cover on cutter housing free wheeling side.



9 Undo the cutter shaft.

NOTE: The cutter shaft doesn't need to be totally removed to remove rotating segments and feed hook.

Strike carefully the key-joint shaft center with a bronze punch from transmission side.

Be careful, hold each rotating segment and feed hook when you remove the cutter shaft.

NOTE: Never let a segment or a feed hook fall down out of control.

Hardened steel segment and feed hook are brittle and can crack if they are dropped.

First install the rotating segments and feed hook

To install rotating segments and the feed hook it is recommended that the granulator be sent to Conair.

- 1 Clean properly the inside of cutter housing, scrapers and knife position for the fixed knives.
- 2 Grease the cutter shaft properly, use graphite grease.
- 3 Install rotating segments “C” and feed hook “B” on the cutter shaft.

Note: The granulator models 1014 and 1018 with more than one feed hook. The feed hooks should be installed with displaced positions.

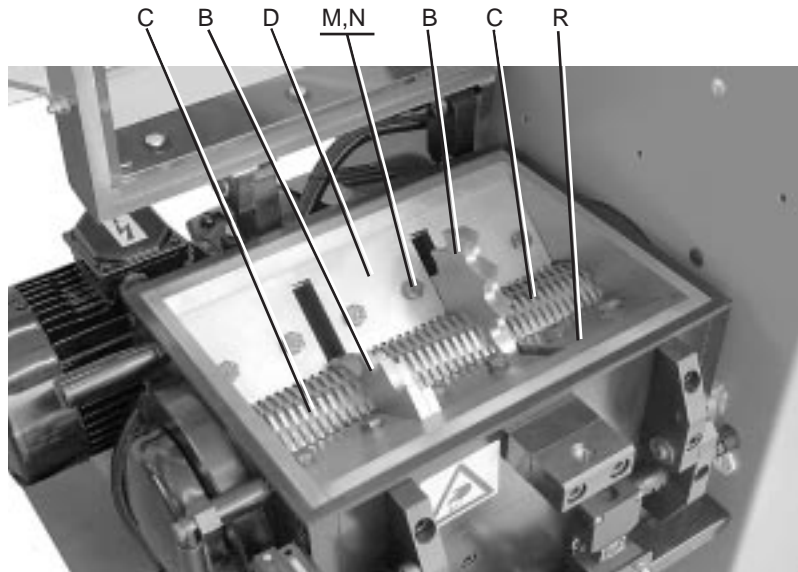

Strike carefully the key-joint shaft center, use a plastic- or rubber mallet from the cutter housing free wheeling side.

At the same time install rotating segments and feed hook. Make sure that the key fits into segments and feed hook.

- 4 Install the drive belt.
Turn motor and reduction gear backwards so that the drive belt can be installed without tension.

- 5** Fasten reduction gear against the cutter housing with the 4 hex head screws “V”, tightening torque 220 Nm.

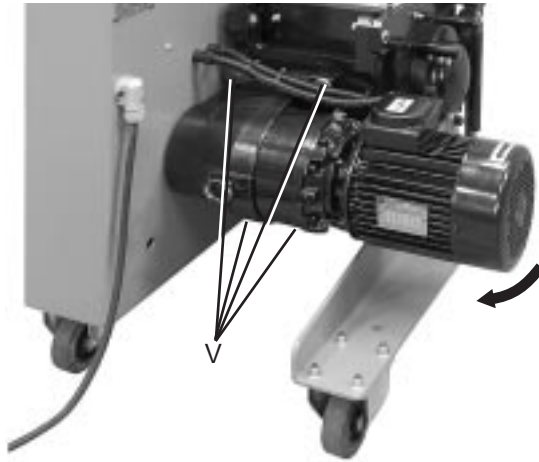

- 6** Install the support ring “O” on motor pulley.

- 7** Install the cutter pulley “S”.

- 8** Fasten the cutter pulley.

Lock the feed hook against the cutter housing with a piece of wood. Fit screw and washer to cutter shaft in the center of cutter pulley.

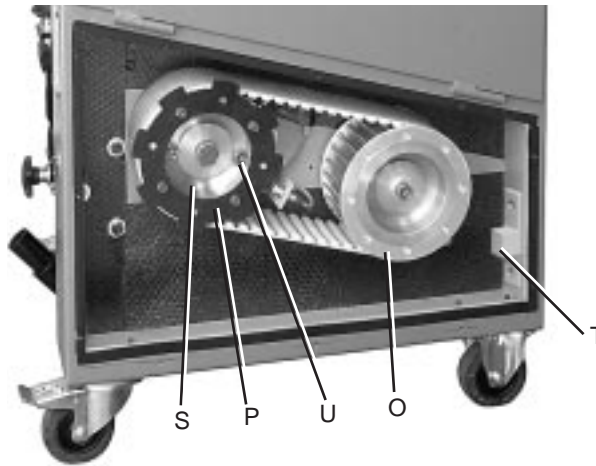

Fasten the cutter pulley with tightening torque 220 Nm.

- 9 Fit the 2 socket cap screws "U" from the remover in cutter pulley center.
- 10 Granulators with Automatic reversing system, install the indication ring "P" on cutter pulley.

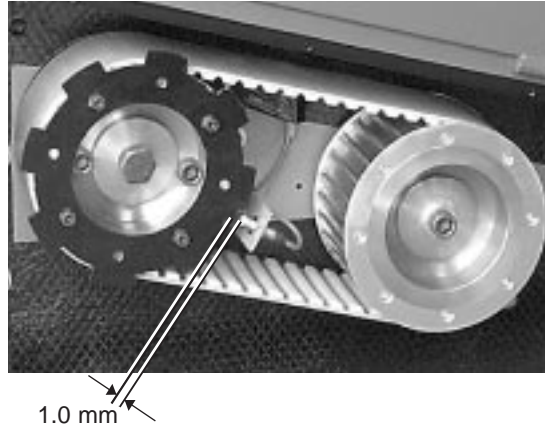

Check and adjust the clearance between indication ring and inductive sensor.
Clearance 1.0 mm.

- 11 Remove the wooden piece from cutter housing.
 - 12 Replace the remover. (*See step 9*)
 - 13 Install the bearing cover "X" on cutter housing free wheeling side.
 - 14 Install and fasten the covering plate to transmission.
- Then install the fixed knives**
- 15 The fixed knives "D" should be properly cleaned.
 - 16 Close the upper part of cutter housing.
 - 17 Check that the knife position for fixed knives is properly cleaned.

- 18** Then install the fixed knives.
Install the screws and washers to fixed knives and fasten so that the screws lightly support the knives.
- 19** Rotate the cutter a few turns and carefully check that rotating segments and feed hook can pass the fixed knives freely.
- 20** Set the knife clearance, adjust the fixed knife positions against rotating segments.

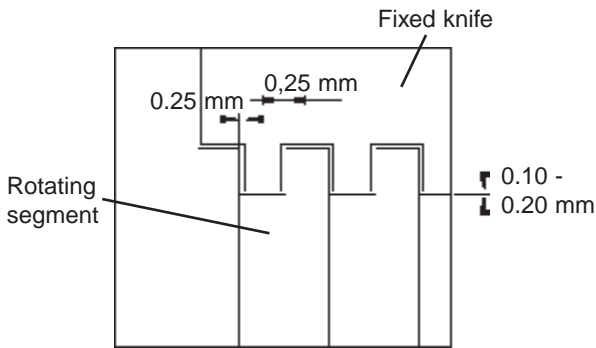

- 21** Tighten the screws “M” to the fixed knives with an alternated increased torque to 85 Nm.
- 22** Close hopper and install the granule bin.

NOTE: Sign in the service schedule, chapter 12, when changing of fixed knives, rotating segments and feed hook is completed.

5.6 Grinding of Cutting Parts

Note: The instruction for grinding cutting parts refers to 3 different parts.

Grinding of: – fixed knives
– rotating segments
– feed hook



Be careful when you handle cutting parts!



Cutting parts are sharp and can cause personal injury.



NOTE: Hardened steel cutting parts are brittle and can crack if they are dropped or handled carelessly.

Cool the cutting parts during grinding

Cool the cutting parts during grinding, grind slowly and make sure that no heat is generated.

Grinding fixed knives

Cutting angle 90°.

The fixed knives can be turned over and two sides can be grinded.

This means that the knives can be turned over and two cutting sides can be used before they have to be reground.

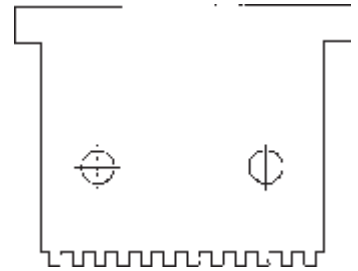

During grinding use a surface grinder with magnetic table.

Minimum measure is 10 mm for fixed knives.

After that, the knives are used up and must be replaced by new ones.

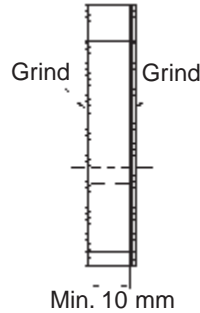

Grinding rotating segments and feed hook

Only qualified individuals should remove, grind and install the rotating segments and feed hook.

To grind rotating segments and the feed hook we recommend that they be sent to Conair.

Rotating segment

The edges are angled on rotating segments.

The segment edges should be grinded with diameter 6 mm.

NOTE: The minimum measure is 4.5 mm on rotating segment heads

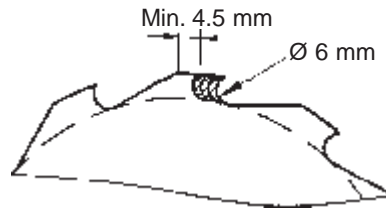

After that, the rotating segments are used up and must be replaced by new ones.

Rotating feed hook

The rotating feed hook direction is reversible and two directions can be grinded.

The rotating feed hook should be grinded with a tripple and double contour profile.

It is important to keep the double tripple profile. It is also important to keep the specified angles and measures between 1st and 2nd profile.

The profile edges on the feed hook should be sharp and with 90° cutting angle.

The diameter in rotating feed hook contour base should be grinded to diameter 21 mm.

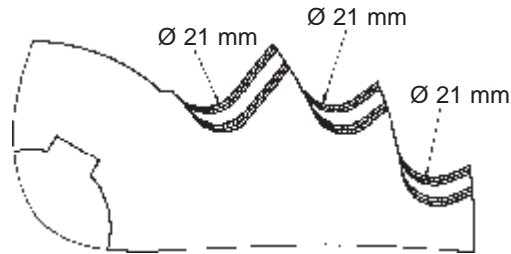

5.7 Transmission

The machine is driven by a ribbed belt. Check annually or each 8000 running hours, the drive belt condition and the oil level in reduction gear.

- Check that the hopper is empty, then stop the granulator with the stop button.
- Turn the main switch to position “0” (Off).
- Press the emergency stop button.
- Pull the main plug out of the main outlet.



Reduction gear

The reduction gear is filled with mineral oil on delivery:

AGIP ROTRA MT 80W90 (ISO VG 220).

In normal circumstances, the oil does not need to be changed.



NOTE: Never fill above level indicator.



NOTE: Mineral oil and synthetic oil should never be mixed.

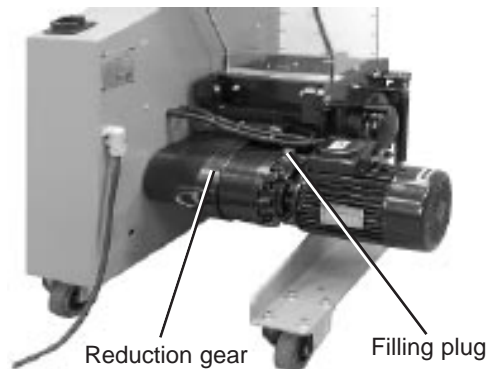

Check the drive belt condition

- Undo and remove the covering plate to transmission.



- Rotate the pulley with the drive belt a several turns.



WARNING: Pinch risk between pulley and drive belt.

Check that the drive belt is intact and does not have any cracks. Change the belt as necessary.

To change the drive belt, read chapter 5.5 "Changing of fixed knives, rotating segment and feed hook" which contains instructions to remove and install the drive belt.

5.8 Lubrication

Granulator

All bearings in the granulator are lubricated for life and can not be lubricated later on.

Options

6.1 Automatic reversing system	6-2
– Function	6-3
– Program relay	6-3
6.2 Level monitor	6-5
– Setting the paddle monitor sensitivity . .	6-6
6.3 Hours counter	6-7

6.1 Automatic reversing system

To easily avoid stopping and overloading of the granulator, the “Reversing system” is a practical option.

The Automatic reversing system normally reverses the cutter during continuous operation each 6 minutes to avoid stopping and overloading. The cutter stops, reverses half a turn, stops and re-starts forward automatically.

Normal settings

The program relay settings on delivery:

After 6 minutes of operation the cutter stops, reverses 1, 2 seconds and then re-starts forward.

Overloading

When the cutter is overloaded, blocked and stops, the Automatic reversing system sense the overloading.

The Automatic reversing system reverses the cutter which changes direction and back half a turn, then stops and re-starts forward automatically.

The third consecutive reversing, stops the granulator.

NOTE: The Automatic reversing system doesn't protect the granulator, if metal parts falls down into the cutter housing.

Overload settings

The relay is set so that:

After 1 second the cutter stops, and reverses the cutter.

The cutter reverses 1, 2 seconds and re-starts forward (1, 5 sec stop during demagnetizing).

The third consecutive reversing, stops the granulator.

Reset the granulator after third stop

- 1 Stop the granulator with the stop button.
- 2 Open the hopper, granule bin and cutter housing, read chapter 5.2.
- 3 Clean the granulator, read chapter 5.4.
- 4 Re-start the granulator.

Function

A program relay in electrical cabinet, together with an inductive sensor in the transmission controls the Automatic reversing function.

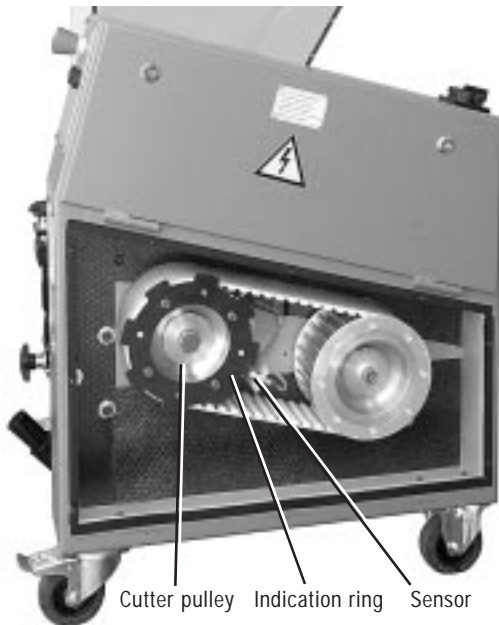

Program relay

The operation time of the granulator, the time before the auto-reversing, can be set in the program relay. The reversing time can not be set.

The time for sensing overload-stop and following reversing sequence can not be adjusted.

Programming the relay

NOTE: All electrical maintenance and service must be done by a competent electrician.

The door to the electrical cabinet should always be securely closed and locked when the granulator is in operation.

The key is kept by the person who is responsible for granulator safety, service and maintenance.

Stop the granulator.

NOTE: Never stop the granulator before all material in the hopper and cutter housing are completely granulated.

- 1 Stop the granulator with the stop button.
- 2 Press the emergency stop button.
- 3 Turn the main switch to position "1" (On).

Open the electrical cabinet.

Show parameters

- Press "ESC" and "OK" at same time.
- Select "Set Param" with ▾
- Press "OK"

Set parameters

- Press "OK" for come to T = "0" 6:00
- To move marking use ▷ or ◁
- To change value use ▲ or ▼
- To confirm the settings press "OK"
- To back menu press "ESC"
- Press "ESC"
- Press ▲

At overloading

When the cutter is overloaded, blocked and stops, the Automatic reversing system senses the overloading.

After the third time reversing direction the granulator stops and the relay indicate.

Relay normal position

```
REV SYSTEM
06:00m
01:31m
000000
```

Operation time before stop and reversing
Actual operation time

```
Set Clock
>Set Param
```

```
B28:T
T = 06:00m
Ta= 00:00m
```

Parameter
Operation time before stop and reversing
Actual operation time

```
B01:T
T = 00:00m
Ta=01:00m
```

```
I:123456
Mo 09:00
Q:1234 RUN
```

```
REV STOP
000003
```

6.2 Level Monitor



The granule bin can be equipped with an optional level monitor, designed as a paddle monitor.

The paddle monitor senses the granulate level in the granule bin and stops the granulator, or the granulator feed device conveyor etc. when the level of granulate in the granule bin is too high.

The paddle monitor has three standard settings when manufactured:

- 1** The paddle monitor stops the granulator.
- 2** The paddle monitor stops the granulator and lights up the indicator light.
- 3** The paddle monitor lights up the indicator light.

Setting the paddle monitor sensitivity

Paddle monitor sensitivity is adjustable

- Open, unscrew the housing covering above the paddle monitor microswitches.
- Adjust the position of the torsion spring.
Use needle nose pliers to change the torsion spring position.
The normal setting of the torsion spring is in the 2nd hole from the left.



Reducing paddle monitor sensitivity

(The paddle monitor cuts the current slower)

- Move the torsion spring to the left.

Increasing paddle monitor sensitivity

(The paddle monitor cuts the current faster)

- Move the torsion spring to the right.

6.3 Hours Counter



The hours counter only counts the time that the granulator cutter is moving.

The hours counter can not be re-set.

Electricity

Electricity 7-2

Never change or modify the basic electrical settings of the granulator, without first obtaining permission from the Conair Head Office.

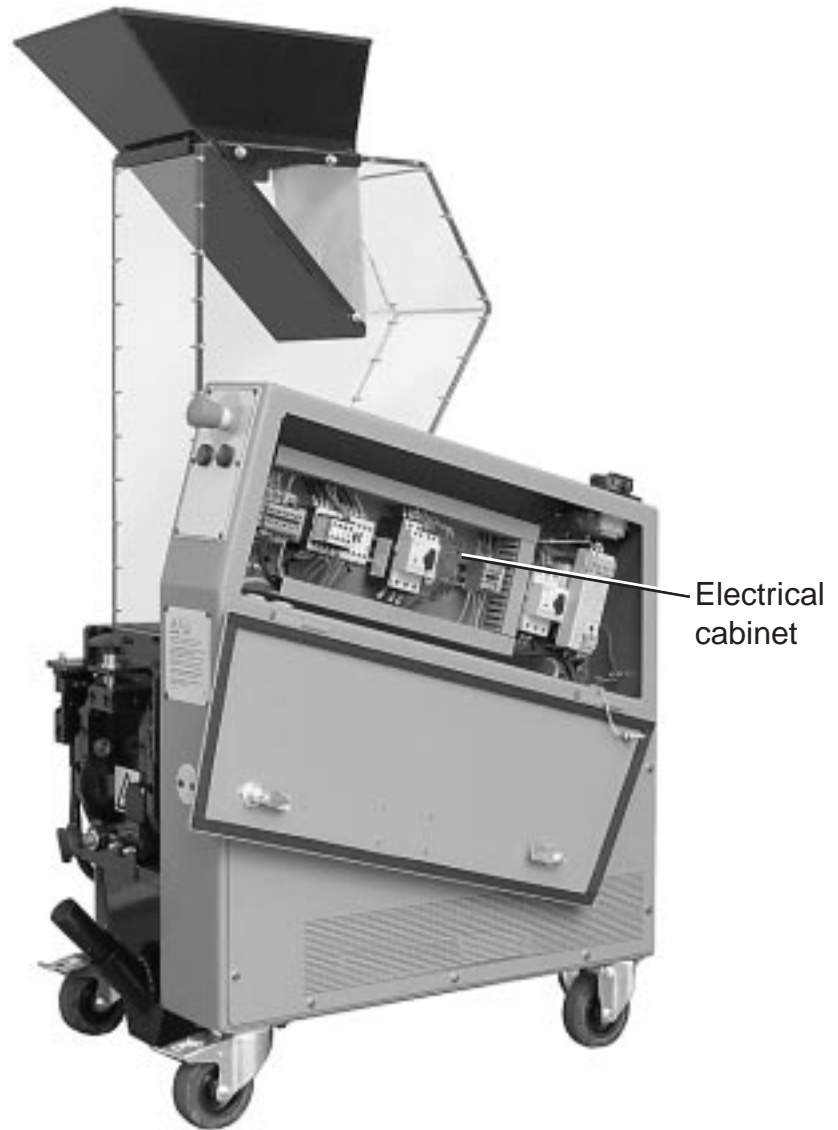

If the granulator settings are changed, the machine can be seriously damaged. All Warranties and Conair's Product Liability will be void, if the basic settings of the granulator are changed.

All maintenance and service work must be done by trained and competent personnel!

Electrical installation must only be done by a competent electrician!



The granulator must never be started if the electrical cabinet door is open.



The electrical cabinet door shall always be securely installed, closed and locked when the granulator is in operation!



The key for the electrical cabinet door is a safety component. The key must be kept by the person who is responsible for granulator safety, service and maintenance.



The electrical cabinet door must never be opened when the granulator is in operation.

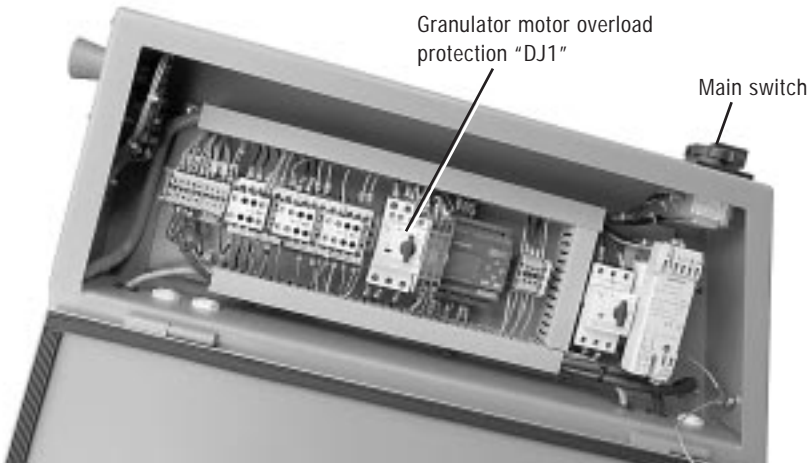

Troubleshooting

- 8.1 Troubleshooting 8-2
 - If the granulator does not start . . . 8-2
 - Check the granulator options . . . 8-3
 - If the granulator does not start after
normal troubleshooting 8-4

8.1 Troubleshooting

If the granulator does not start

- Check whether the granulator emergency stop has been pressed.
Reset, turn the knob in the direction of the arrow (counter-clockwise).
- Check that the granulator main plug is connected to the main power.
- Check that the main switch is in position “1” (On).
- Check that the star knobs on the hopper and granule bin are properly screwed all the way in.

It is not possible to start the granulator, if the star knobs, the hopper and granule bin are not properly screwed all the way in. The safety switches then cut the current.

- Check the motor protection switch for the granulator motor.
The granulator has an motor protection switch “DJ1” in the electrical cabinet which trips if you block or overload the granulator.
If the motor protection switch has switched “Off”, the switch will be in position “0”.
Reset - turn the switch button to position “1”.
Empty and clean the granulator before re-starting.

NOTE: Put the main switch in position “0” (Off). Pull the granulator main plug out of the electrical outlet before cleaning of the granulator.

Reset



Check the granulator options

Automatic reversing system

At overloading or stopping, the cutter reverses direction. After the third time operating in reverse direction the granulator stops.

Reset the granulator:

- Stop the granulator with the stop button.
- Clean the granulator, read chapter 5.4.
- Re-start the granulator.

Automatic reversing system doesn't reverse the cutter and the motor protection switch for the granulator motor trips.

- Stop the granulator with the stop button.
- Undo and remove the covering plate to transmission.

Check and adjust the clearance between indication ring and inductive sensor to Automatic reversing system. Clearance 1.0 mm.

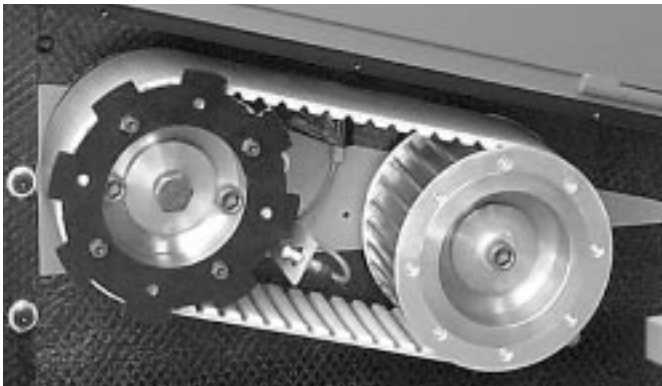

The clearance between indication ring and inductive sensor should be max. 1.0 mm.

Paddle monitor

The paddle on the paddle monitor should rotate during operation.

- If the paddle monitor paddle does not rotate:
Check that the paddle monitor plug is correctly located in its socket.
- If the paddle monitor stops the granulator and the warning-lamp light is lit to early or not at all.
Adjust paddle monitor sensitivity, please refer to section 6.2 “Setting paddle monitor sensitivity”.
- The paddle monitor stops the granulator when the granulate level in the granule bin is too high.
Empty the granule bin and re-start the granulator.

If the granulator does not start after normal fault finding.

Put the main switch in position “0” (Off).

Press the emergency stop button.

Pull the granulator main plug out of the electrical outlet.

Contact the person responsible for service and maintenance.

IMPORTANT: All electrical maintenance must be done by a competent electrician.

Spare Parts List

– Ordering spare parts	9-2
9.1 Cutter Housing	9-3
9.2 Fixed Knives and Cutting Parts	9-4
9.3 Hopper, Flaps, Feed Components	9-5
9.4 Transmission	9-6
9.5 Granule Bin	9-7
9.6 Stand	9-8
9.7 Paddle monitor	9-9

Ordering spare parts

Only use spare parts supplied by Conair to replace machinery components.

Please include in your order:

- Designation from the identification plate on the machine.
- Serial number from the identification plate on the machine.
- Parts in this spare parts list
- Quantity in this spare parts list

9.1 Cutter Housing

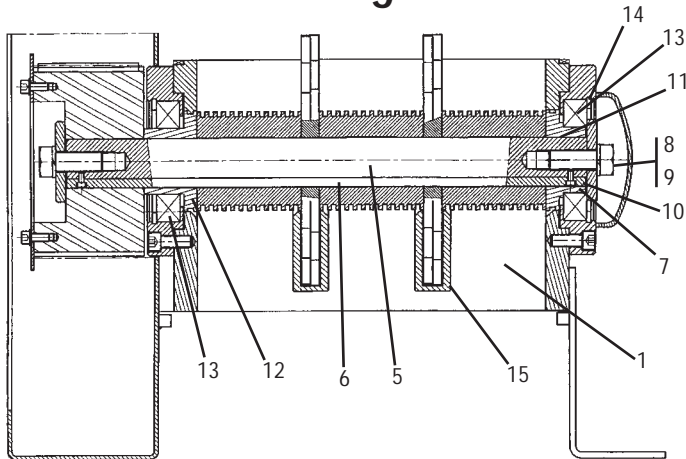

Pos	Qty.	Art. no.	Description	Note.		
			Cutter housing 1010			
			Cutter housing 1014			
			Cutter housing 1018			
1	1	-	Cutter housing 1010			
	-	1	- " -	1014		
	-	1	- " -	1018		
2	2	2	3	Shaft, cutter housing		
3	4	4	6	Socket cap screw, shaft, cutter housing		
4	4	4	6	Washer, shaft, cutter housing		
5	1	alt	-	Cutter shaft 0,75 kW		
	alt	1	1	Cutter shaft 1,80 kW		
6	1	alt	-	Key, cutter shaft 0,75 kW		
	alt	1	1	Key, cutter shaft 1,80 kW		
7	2	2	2	Socket cap screw, key, cutter shaft		
8	1	1	1	Screw		
9	1	1	1	Spring washer		
10	1	1	1	Washer		
11	1	1	1	Flange, free wheeling side		
12	1	1	1	Flange, driving side		
13	2	2	2	Ball bearing	6213-2RS1	
14	2	2	2	Locking ring		
15	1	2	3	Guide, rotating feed hook		
16	1	1	1	Cover		
17	2	2	2	Socket cap screw		
18	1	1	1	9-92993	Handle	
19	1	-	-	9-92994	Gas spring	1010
	-	1	-	9-92995	- " -	1014
	-	-	1	9-92996	- " -	1018
20	1	1	1	9-92997	Tool with chain, cutter	

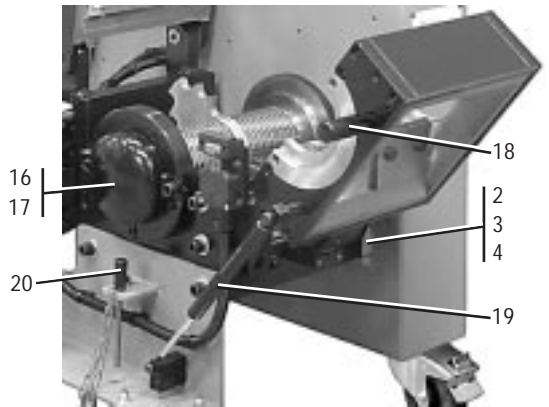

9.2 Fixed Knives and Cutting Parts

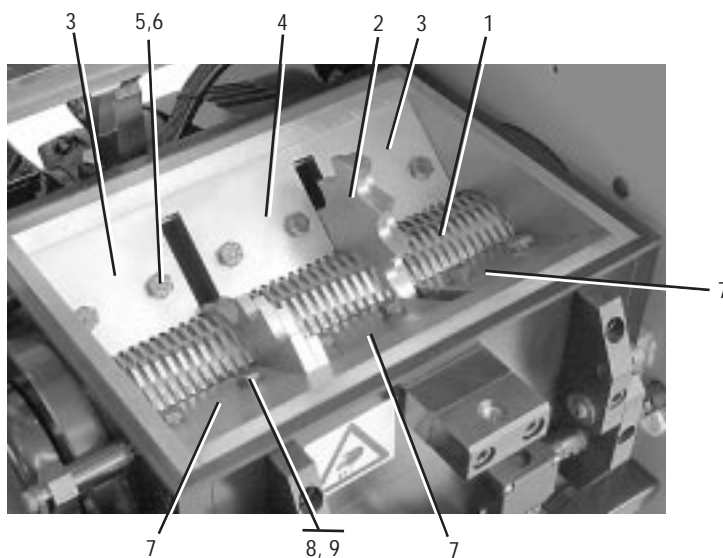

Pos	Qty.	Art. no.	Description	Note.		
			Granulator 1010			
			Granulator 1014			
			Granulator 1018			
1	2	3	4	9-92998	Rotating segment	
2	1	2	3	9-92999	Rotating feed hook	
3	2	2	2	9-93000	Fixed knife, side	
4	-	1	2	9-93001	Fixed knife, center	
5	4	6	8		Hex head screw	fixed knife
6					Washer	screw, fixed knife
7	2	3	4	9-93002	Scraper, rotating segment	
8	4	6	8		Hex head screw	scraper
9	4	6	8		Washer	screw, scraper

9.3 Hopper, Flaps, Feed Components

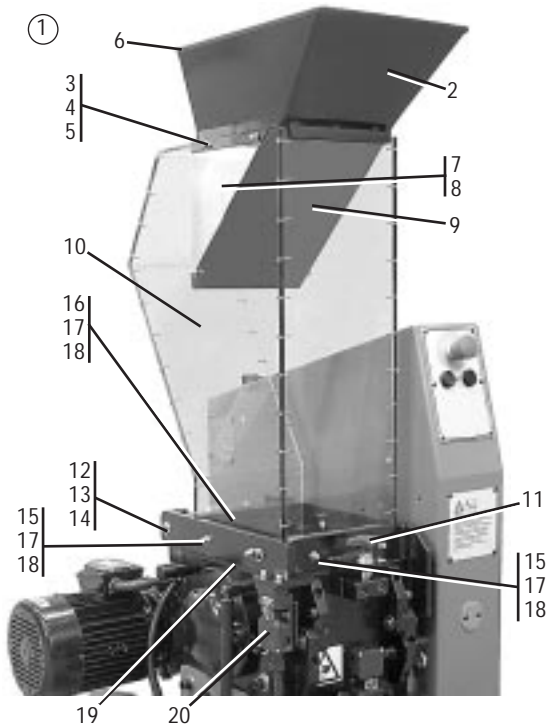

Pos	Qty.	Art. no.	Description
			Granulator 1010
			Granulator 1014
			Granulator 1018
1	1	- -	Hopper complete 1010
	-	1 -	Hopper complete 1014
	-	- 1	Hopper complete 1018
2	1	- -	Hopper funnel 1010
	-	1 -	Hopper funnel 1014
	-	- 1	Hopper funnel 1018
3	9	9 9	Flange screw
4	9	9 9	Washer
5	9	9 9	Nut, locking
6	1	1 1	Protection sealing, hopper funnel
7	1	- -	Flap 1010
	-	1 -	Flap 1014
	-	- 1	Flap 1018
8	1	- -	Holder, flap, hopper 1010
	-	1 -	Holder, flap, hopper 1014
	-	- 1	Holder, flap, hopper 1018
9	1	- -	Guiding plate 1010
	-	1 -	Guiding plate 1014
	-	- 1	Guiding plate 1018
10	1	- -	Hopper polycarbonate 1010
	-	1 -	Hopper polycarbonate 1014
	-	- 1	Hopper polycarbonate 1018
11	1	1 1	Star knob
12	2	2 3	Shaft, hopper
13	4	4 6	Socket cap screw
14	4	4 6	Washer
15	6	7 10	Flange screw
16	2	3 4	Flange screw
17	8	10 14	Washer
18	8	10 14	Nut, locking
19	1	1 1	Sealing, hopper/cutter housing
20	1	1 1	Safety switch with mounting kit complete

9.4 Transmission

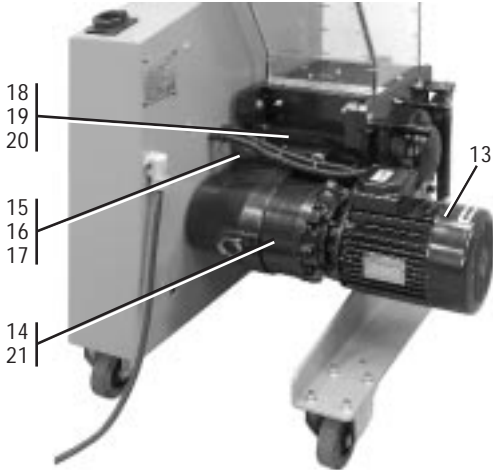
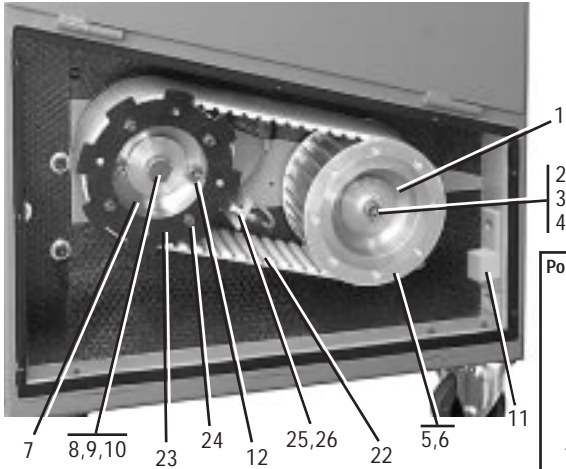

Pos	Qty.	Art. no.	Description
			Granulator 1010
			Granulator 1014
			Granulator 1018
			Granulator 1010 with Automatic reversing system
			Granulator 1014 with Automatic reversing system
			Granulator 1018 with Automatic reversing system
1	1 or 1	- 1 or 1	Motor pulley 0.75 kW
			Motor pulley 1.80 kW
2	1	1	Socket cap screw
3	1	1	Spring washer
4	1	1	Washer
5	2 or 2	- 2 or 2	Support ring, motor pulley 0.75 kW
			Support ring, motor pulley 1.80 kW
6	16	16	Socket cap screw, support ring
7	1 or 1	- 1 or 1	Cutter pulley 0.75 kW
			Cutter pulley 1.80 kW
8	1	1	Hex head screw
9	1	1	Spring washer
10	1	1	Washer
11	1	1	Remover
12	2	2	Socket cap screw
13	1 or 1	- 1 or 1	9-93003 Motor 0.75 kW
			9-93004 Motor 1.80 kW
14	1 or 1	- 1 or 1	Reduction gear 0.75 kW
			Reduction gear 1.80 kW
15	4	4	Hex head screw
16	4	4	Spring washer
17	4	4	Washer
18	1 or 1	- 1 or 1	Bracket, reduction gear 0.75 kW
			Bracket, reduction gear 1.80 kW
19	4	4	Socket cap screw
20	4	4	Washer
21	-	-	Oil, reduction gear 1.0 lit.
22	1 or 1	- 1 or 1	9-93005 Drive belt 50AT20/1200SYN
			9-93006 Drive belt 100AT20/1200SYN
23	-	-	Indication ring
24	-	-	Socket cap screw, indication ring
25	-	-	Sensor
26	-	-	Relay, Automatic reversing system

9.5 Granule Bin

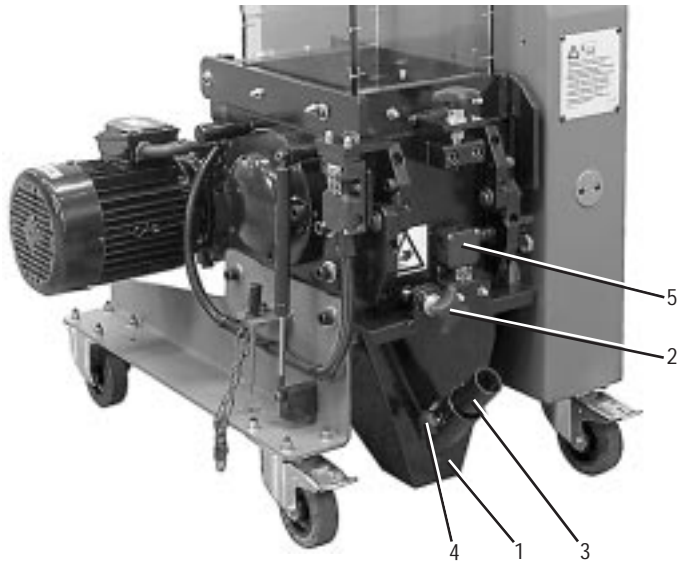

Pos	Qty.	Art. no.	Description
	┌		Granulator 1010
		┌	Granulator 1014
		┌	Granulator 1018
1	1	-	Granule bin 1010
	-	1	Granule bin 1014
	-	-	Granule bin 1018
2	1	1	Star knob, locking granule bin
3	1	1	Suction pipe
4	1	1	Star knob, suction pipe
5	1	1	Safety switch with mounting kit, complete

9.6 Stand

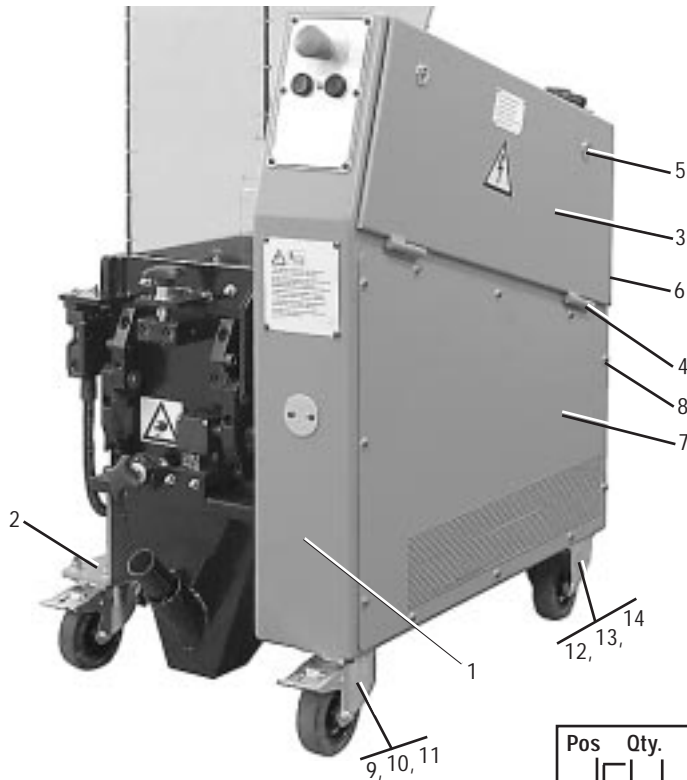

Pos	Qty.	Art. no.	Description
			Granulator 1010
			Granulator 1014
			Granulator 1018
1	1		Stand
2	1		Support, stand
3	1		Door, electrical cabinet
4	2		Hinge
5	2		Lock, door lock
6	1		List, edge protection
7	1		Covering plate, transmission
8	11		Socket cap screw M5
9	2	9-93007	Wheel, turnable with brake
10	8		Socket cap screw
11	8		Nut, locking
12	2	9-93008	Wheel, fixed
13	8		Socket cap screw
14	8		Nut, locking

9.7 Paddle monitor

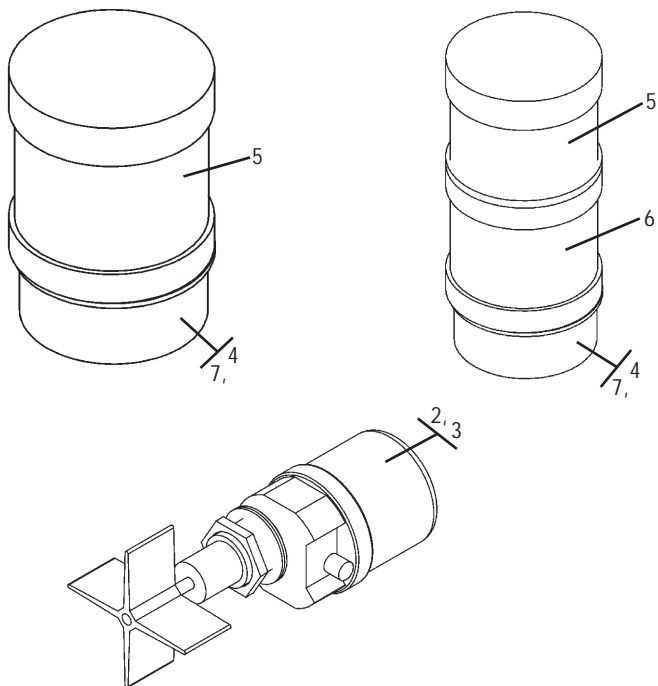

Pos	Qty.	Art. no.	Description
1	1	3-40477	Paddle monitor with warning lamp 24V
		3-40476	Paddle monitor with warning lamp and siren 24V
2	1	911105	Paddle monitor RP-5
3	1	911266	Connector 8-pol
4	1	911532	Adapter
5	1	911523	Warning lamp 24V
6	-	911529	Siren
7	2	9404084	Socket cap screw M4

Layout

CM Granulator 10-2

CM granulator

Note: Dimentions are given in millimeters.

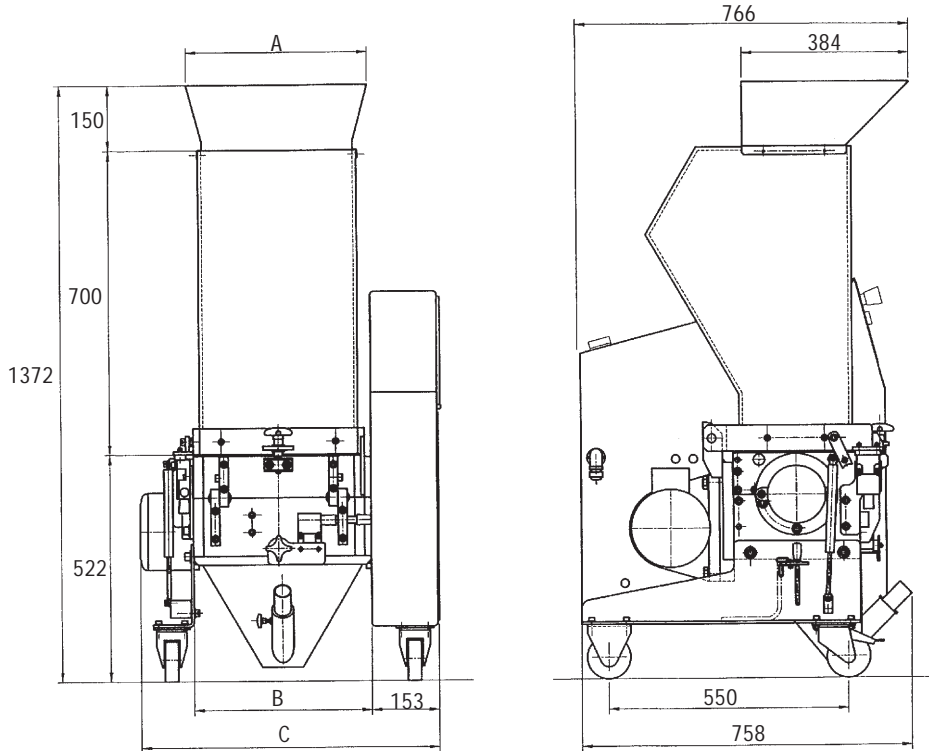

	1010	1014	1018
A	291	412	530
B	284	405	525
C	605	680	773

Transport and Storage

11.1	General	11-2
11.2	Transport	11-2
11.3	Storage	11-5

11.1 General

The machine must be packaged and transported by trained personnel. All instructions must be observed, to avoid damage.

11.2 Transport

Read through all of chapter 11 before transporting the machine.

Outdoors

If the machine must be transported exposed to the elements, all unpainted components on the machine must be treated with rust preventer.

After this, the machine must be packed in protective plastic film and fixed to a transport pallet with PET straps or tension straps.

Indoors

The machine can be transported short distances on dry, even surfaces on its transport wheels.

Two of the machine's transport wheels can be turned, which facilitates transport.

If the machine has to be transported longer distances, it should be fixed to a transport pallet with PET straps or tension straps. It can then be transported on a forklift truck or traversing crane.

Lifting the machine

The machine weighs 335 - 385 kg with packaging.

Space requirements, see Layout, chapter 10.

The machine can be lifted and handled with a fork-lift truck or a traversing crane.

With a fork-lift truck

The machine can be lifted and handled with a fork-lift truck.

- 1 Set the fork width on fork-lift truck to 400 mm.
- 2 Remove the granule bin.
- 3 Drive in the fork-lift truck and make sure that the lifting forks balancing the granulator, then lift the machine.

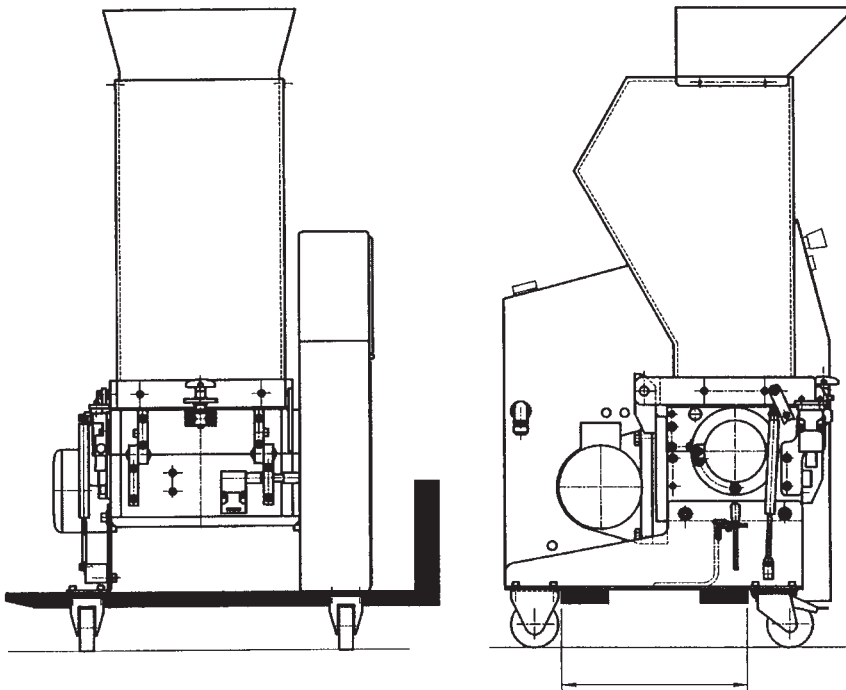

With traversing crane and a lifting strop

The machine can be lifted by means of a double strop and a lifting yoke. The length of the strop should be at least 5 metre (10.0 m circumference).

- 1 Remove the granule bin.
- 2 Install the lifting strap underneath the granulator stand.
- 3 Then install a lifting yoke.

Use a traversing crane or a fork-lift truck and then lift the machine as shown in the illustrations.

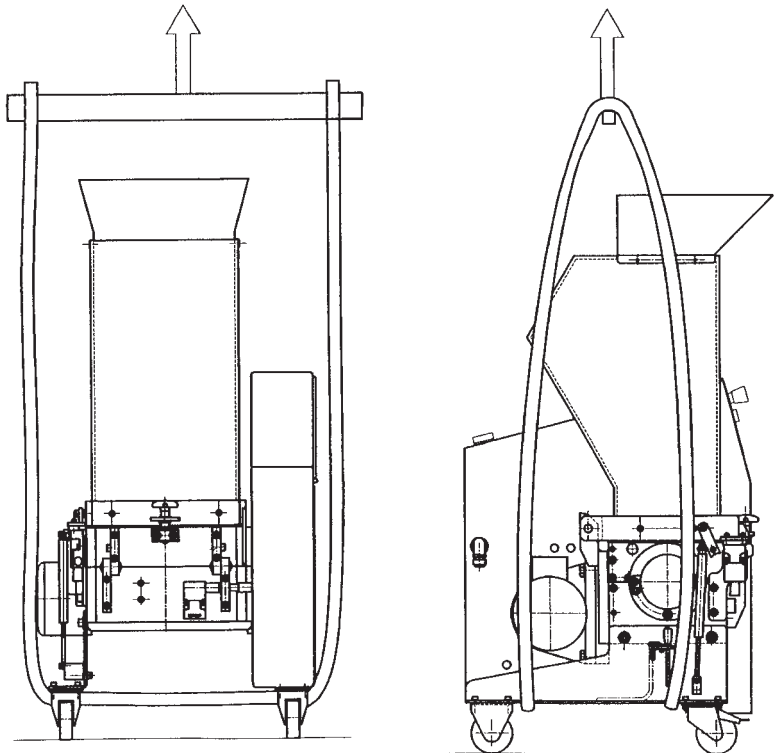

11.3 Storage

Long term storage

- Store the machine in dry premises with an even temperature.
- Treat all unpainted surfaces on the machine at once with rust preventer.

Use

Castrol DWX 22 which will protect the machine for up to 12 months.

Or Castrol DWX 160 which will protect the machine for 24 - 36 months.



Technical Specifications

Cutter housing	12-2
Motor	12-2
Cutting parts and fixed knives	12-2
Knife clearance	12-2
Granule bin	12-3
Transmission	12-3
Sound level	12-3
Weight	12-3
Maintenance schedule	12-4
Machine data	12-4
Installation	12-4
Safety, maintenance and service	12-4
Inspection	12-5
Daily inspection	12-5
Weekly inspection	12-5
Every 6 months or 4000 running hours	12-9
Check annually or 8000 running hours	12-11
Changing of cutting parts	12-12
Malfunctions	12-13
Notes	12-14

Cutter housing

Cutter housing opening

1010241 x 223 mm.
1014241 x 343 mm.
1018241 x 464 mm.

Motor

Granulator model	Motor power	Cutter speed
1010	0.75 kW	25 rpm.
- option	1.80 kW	27 rpm.
1014	1.80 kW	27 rpm.
- option	0.75 kW	25 rpm.
1018	1.80 kW	27 rpm.

Cutting parts and fixed knives

Rotating	feed hook Ø 248	Segment
10101 pcs. 2 pcs.
10142 pcs. 3 pcs.
10183 pcs. 4 pcs.
Fixed knives		
10102 pcs.
10143 pcs.
10184 pcs.

Knife clearance

side rotating segment – fixed knife	0.25 mm.
knife edge rotating segment – fixed knife	0.10 - 0.20 mm.
Tightening torque, fixed knives	85 Nm.

Granule bin

Capacity

1010	7.0 lit.
1014	10.0 lit.
1018	13.0 lit.

Transmission

Drive belt, motor 0,75 and 1,80 kW, ribbed belt. art.no.

Tightening torque, cutter pulley	220 Nm.
Tightening torque, motor pulley	220 Nm.
Tightening torque, reduction gear	220 Nm.

Sound level

1010	approx. 62 dBA.
1014	approx. 62 dBA.
1018	approx. 62 dBA.

Weight

Motor power	0.75 kW	1.80 kW
1010315 kg.	320 kg.
1014335 kg.	340 kg.
1018355 kg.	360 kg.

Maintenance schedule

Read the instruction manual before maintenance and service work is done.
All maintenance and service work must be done by trained personnel.
If you have any questions, please contact the local Conair distributor or the Conair head office.

Head office: Conair
One Conair Drive, Pittsburgh, PA 15202
Phone: 412-312-6000 Fax: 412-312-6227

Machine data

Machine type: 10 Serial number:
Wiring diagram: Motor: V Hzk W
Year of manufacture: 20

Installation

Electrical installation must be done by a competent electrician.
The machine has been installed in accordance with chapter 3 of this instruction manual.

Date: / 20 Name:.....
Eight hours or one day after first start, the knife clearance and tightening torque of the fixed knives retaining screws has been checked in accordance with chapter 5.5 in this manual.
Date: / 20 Name:.....

Safety, maintenance and service

Contact person responsible for granulator safety, maintenance and service

Name:	Phone:
.....
.....
.....
.....
.....
.....

Inspection

NOTE: The machine must be inspected by trained personnel, please refer to chapter 5.1 of this manual.

Daily inspection

Check the emergency stop function of the machine.
Check that the flap in the hopper is intact. Change a damaged flap at once.

Weekly inspection

Check all electrical cables on the machine. There must never be any damaged cables, loose cables, terminals or components. Call the person responsible for safety, maintenance and service at once.

Check all the functions of the safety systems. Please refer to chapter 4.2 “Safety system” in this manual.

Sign checks when they have been approved. If there are any faults, contact the person responsible for safety, maintenance and service at once.

..... / 20 Sign: / 20 Sign: / 20 Sign:
..... / 20 Sign: / 20 Sign: / 20 Sign:
..... / 20 Sign: / 20 Sign: / 20 Sign:
..... / 20 Sign: / 20 Sign: / 20 Sign:
..... / 20 Sign: / 20 Sign: / 20 Sign:
..... / 20 Sign: / 20 Sign: / 20 Sign:
..... / 20 Sign: / 20 Sign: / 20 Sign:
..... / 20 Sign: / 20 Sign: / 20 Sign:
..... / 20 Sign: / 20 Sign: / 20 Sign:
..... / 20 Sign: / 20 Sign: / 20 Sign:
..... / 20 Sign: / 20 Sign: / 20 Sign:
..... / 20 Sign: / 20 Sign: / 20 Sign:
..... / 20 Sign: / 20 Sign: / 20 Sign:
..... / 20 Sign: / 20 Sign: / 20 Sign:
..... / 20 Sign: / 20 Sign: / 20 Sign:
..... / 20 Sign: / 20 Sign: / 20 Sign:
..... / 20 Sign: / 20 Sign: / 20 Sign:
..... / 20 Sign: / 20 Sign: / 20 Sign:
..... / 20 Sign: / 20 Sign: / 20 Sign:
..... / 20 Sign: / 20 Sign: / 20 Sign:
..... / 20 Sign: / 20 Sign: / 20 Sign:

Every 6 months or 4000 running hours

Check the wear on fixed knives, rotating segment and feed hook. Check the tightening torque of the fixed knives retaining screws.

- | | | | | |
|------------------------|--------------------|-----------------------------|--------------------------------|---|
| / 20 | Fixed knives | <input type="checkbox"/> OK | <input type="checkbox"/> Grind | <input type="checkbox"/> OK tightening torque |
| | Rotating segment | | <input type="checkbox"/> OK | <input type="checkbox"/> Grind |
| | Rotating feed hook | | <input type="checkbox"/> OK | <input type="checkbox"/> Grind Sign: |
| / 20 | Fixed knives | <input type="checkbox"/> OK | <input type="checkbox"/> Grind | <input type="checkbox"/> OK tightening torque |
| | Rotating segment | | <input type="checkbox"/> OK | <input type="checkbox"/> Grind |
| | Rotating feed hook | | <input type="checkbox"/> OK | <input type="checkbox"/> Grind Sign: |
| / 20 | Fixed knives | <input type="checkbox"/> OK | <input type="checkbox"/> Grind | <input type="checkbox"/> OK tightening torque |
| | Rotating segment | | <input type="checkbox"/> OK | <input type="checkbox"/> Grind |
| | Rotating feed hook | | <input type="checkbox"/> OK | <input type="checkbox"/> Grind Sign: |
| / 20 | Fixed knives | <input type="checkbox"/> OK | <input type="checkbox"/> Grind | <input type="checkbox"/> OK tightening torque |
| | Rotating segment | | <input type="checkbox"/> OK | <input type="checkbox"/> Grind |
| | Rotating feed hook | | <input type="checkbox"/> OK | <input type="checkbox"/> Grind Sign: |
| / 20 | Fixed knives | <input type="checkbox"/> OK | <input type="checkbox"/> Grind | <input type="checkbox"/> OK tightening torque |
| | Rotating segment | | <input type="checkbox"/> OK | <input type="checkbox"/> Grind |
| | Rotating feed hook | | <input type="checkbox"/> OK | <input type="checkbox"/> Grind Sign: |
| / 20 | Fixed knives | <input type="checkbox"/> OK | <input type="checkbox"/> Grind | <input type="checkbox"/> OK tightening torque |
| | Rotating segment | | <input type="checkbox"/> OK | <input type="checkbox"/> Grind |
| | Rotating feed hook | | <input type="checkbox"/> OK | <input type="checkbox"/> Grind Sign: |
| / 20 | Fixed knives | <input type="checkbox"/> OK | <input type="checkbox"/> Grind | <input type="checkbox"/> OK tightening torque |
| | Rotating segment | | <input type="checkbox"/> OK | <input type="checkbox"/> Grind |
| | Rotating feed hook | | <input type="checkbox"/> OK | <input type="checkbox"/> Grind Sign: |
| / 20 | Fixed knives | <input type="checkbox"/> OK | <input type="checkbox"/> Grind | <input type="checkbox"/> OK tightening torque |
| | Rotating segment | | <input type="checkbox"/> OK | <input type="checkbox"/> Grind |
| | Rotating feed hook | | <input type="checkbox"/> OK | <input type="checkbox"/> Grind Sign: |

..... / 20	Fixed knives	<input type="checkbox"/> OK	<input type="checkbox"/> Grind	<input type="checkbox"/> OK tightening torque
	Rotating segment	<input type="checkbox"/> OK	<input type="checkbox"/> Grind	
	Rotating feed hook	<input type="checkbox"/> OK	<input type="checkbox"/> Grind	Sign:
..... / 20	Fixed knives	<input type="checkbox"/> OK	<input type="checkbox"/> Grind	<input type="checkbox"/> OK tightening torque
	Rotating segment	<input type="checkbox"/> OK	<input type="checkbox"/> Grind	
	Rotating feed hook	<input type="checkbox"/> OK	<input type="checkbox"/> Grind	Sign:
..... / 20	Fixed knives	<input type="checkbox"/> OK	<input type="checkbox"/> Grind	<input type="checkbox"/> OK tightening torque
	Rotating segment	<input type="checkbox"/> OK	<input type="checkbox"/> Grind	
	Rotating feed hook	<input type="checkbox"/> OK	<input type="checkbox"/> Grind	Sign:
..... / 20	Fixed knives	<input type="checkbox"/> OK	<input type="checkbox"/> Grind	<input type="checkbox"/> OK tightening torque
	Rotating segment	<input type="checkbox"/> OK	<input type="checkbox"/> Grind	
	Rotating feed hook	<input type="checkbox"/> OK	<input type="checkbox"/> Grind	Sign:
..... / 20	Fixed knives	<input type="checkbox"/> OK	<input type="checkbox"/> Grind	<input type="checkbox"/> OK tightening torque
	Rotating segment	<input type="checkbox"/> OK	<input type="checkbox"/> Grind	
	Rotating feed hook	<input type="checkbox"/> OK	<input type="checkbox"/> Grind	Sign:
..... / 20	Fixed knives	<input type="checkbox"/> OK	<input type="checkbox"/> Grind	<input type="checkbox"/> OK tightening torque
	Rotating segment	<input type="checkbox"/> OK	<input type="checkbox"/> Grind	
	Rotating feed hook	<input type="checkbox"/> OK	<input type="checkbox"/> Grind	Sign:
..... / 20	Fixed knives	<input type="checkbox"/> OK	<input type="checkbox"/> Grind	<input type="checkbox"/> OK tightening torque
	Rotating segment	<input type="checkbox"/> OK	<input type="checkbox"/> Grind	
	Rotating feed hook	<input type="checkbox"/> OK	<input type="checkbox"/> Grind	Sign:
..... / 20	Fixed knives	<input type="checkbox"/> OK	<input type="checkbox"/> Grind	<input type="checkbox"/> OK tightening torque
	Rotating segment	<input type="checkbox"/> OK	<input type="checkbox"/> Grind	
	Rotating feed hook	<input type="checkbox"/> OK	<input type="checkbox"/> Grind	Sign:

Check annually or 8000 running hours

Check the drive belt condition, oil level in reduction gear and sealings to cutter house bearings.

..... / 20	Drive belt	<input type="checkbox"/> OK	<input type="checkbox"/> Replaced	
	Reduction gear, oil level	<input type="checkbox"/> OK	<input type="checkbox"/> Adjusted	
	Sealings cutter house bearings	<input type="checkbox"/> OK	<input type="checkbox"/> Replaced	Sign:
..... / 20	Drive belt	<input type="checkbox"/> OK	<input type="checkbox"/> Replaced	
	Reduction gear, oil level	<input type="checkbox"/> OK	<input type="checkbox"/> Adjusted	
	Sealings cutter house bearings	<input type="checkbox"/> OK	<input type="checkbox"/> Replaced	Sign:
..... / 20	Drive belt	<input type="checkbox"/> OK	<input type="checkbox"/> Replaced	
	Reduction gear, oil level	<input type="checkbox"/> OK	<input type="checkbox"/> Adjusted	
	Sealings cutter house bearings	<input type="checkbox"/> OK	<input type="checkbox"/> Replaced	Sign:
..... / 20	Drive belt	<input type="checkbox"/> OK	<input type="checkbox"/> Replaced	
	Reduction gear, oil level	<input type="checkbox"/> OK	<input type="checkbox"/> Adjusted	
	Sealings cutter house bearings	<input type="checkbox"/> OK	<input type="checkbox"/> Replaced	Sign:
..... / 20	Drive belt	<input type="checkbox"/> OK	<input type="checkbox"/> Replaced	
	Reduction gear, oil level	<input type="checkbox"/> OK	<input type="checkbox"/> Adjusted	
	Sealings cutter house bearings	<input type="checkbox"/> OK	<input type="checkbox"/> Replaced	Sign:
..... / 20	Drive belt	<input type="checkbox"/> OK	<input type="checkbox"/> Replaced	
	Reduction gear, oil level	<input type="checkbox"/> OK	<input type="checkbox"/> Adjusted	
	Sealings cutter house bearings	<input type="checkbox"/> OK	<input type="checkbox"/> Replaced	Sign:
..... / 20	Drive belt	<input type="checkbox"/> OK	<input type="checkbox"/> Replaced	
	Reduction gear, oil level	<input type="checkbox"/> OK	<input type="checkbox"/> Adjusted	
	Sealings cutter house bearings	<input type="checkbox"/> OK	<input type="checkbox"/> Replaced	Sign:
..... / 20	Drive belt	<input type="checkbox"/> OK	<input type="checkbox"/> Replaced	
	Reduction gear, oil level	<input type="checkbox"/> OK	<input type="checkbox"/> Adjusted	
	Sealings cutter house bearings	<input type="checkbox"/> OK	<input type="checkbox"/> Replaced	Sign:

Changing of cutting parts

- / 20 Rotating segment Rotating feed hook
 Fixed knives Note: Sign:.....
- / 20 Rotating segment Rotating feed hook
 Fixed knives Note: Sign:.....
- / 20 Rotating segment Rotating feed hook
 Fixed knives Note: Sign:.....
- / 20 Rotating segment Rotating feed hook
 Fixed knives Note: Sign:.....
- / 20 Rotating segment Rotating feed hook
 Fixed knives Note: Sign:.....
- / 20 Rotating segment Rotating feed hook
 Fixed knives Note: Sign:.....
- / 20 Rotating segment Rotating feed hook
 Fixed knives Note: Sign:.....
- / 20 Rotating segment Rotating feed hook
 Fixed knives Note: Sign:.....
- / 20 Rotating segment Rotating feed hook
 Fixed knives Note: Sign:.....
- / 20 Rotating segment Rotating feed hook
 Fixed knives Note: Sign:.....
- / 20 Rotating segment Rotating feed hook
 Fixed knives Note: Sign:.....
- / 20 Rotating segment Rotating feed hook
 Fixed knives Note: Sign:.....
- / 20 Rotating segment Rotating feed hook
 Fixed knives Note: Sign:.....
- / 20 Rotating segment Rotating feed hook
 Fixed knives Note: Sign:.....
- / 20 Rotating segment Rotating feed hook
 Fixed knives Note: Sign:.....
- / 20 Rotating segment Rotating feed hook
 Fixed knives Note: Sign:.....

Malfunctions

..... / 20	Fault:
	Action:
	 Sign
..... / 20	Fault:
	Action:
	 Sign
..... / 20	Fault:
	Action:
	 Sign
..... / 20	Fault:
	Action:
	 Sign
..... / 20	Fault:
	Action:
	 Sign
..... / 20	Fault:
	Action:
	 Sign
..... / 20	Fault:
	Action:
	 Sign
..... / 20	Fault:
	Action:
	 Sign
..... / 20	Fault:
	Action:
	 Sign

Notes

..... / 20 Notes:
Action:
..... Sign

..... / 20 Notes:
Action:
..... Sign

..... / 20 Notes:
Action:
..... Sign

..... / 20 Notes:
Action:
..... Sign

..... / 20 Notes:
Action:
..... Sign

..... / 20 Notes:
Action:
..... Sign

..... / 20 Notes:
Action:
..... Sign

..... / 20 Notes:
Action:
..... Sign

..... / 20 Notes:
Action:
..... Sign

..... / 20 Notes:
Action:
..... Sign

..... / 20 Notes:
Action:
..... Sign

..... / 20 Notes:
Action:
..... Sign

..... / 20 Notes:
Action:
..... Sign

..... / 20 Notes:
Action:
..... Sign

..... / 20 Notes:
Action:
..... Sign

We're Here to Help

Conair has made the largest investment in customer support in the plastics industry. Our service experts are available to help with any problem you might have installing and operating your equipment. Your Conair sales representative also can help analyze the nature of your problem, assuring that it did not result from misapplication or improper use.

Additional manuals and prints for your Conair equipment may be ordered through the Customer Service or Parts Department for a nominal fee.

How to Contact Customer Service

To contact Customer Service personnel, call:



From outside the United States, call: 814-437-6861

You can commission Conair service personnel to provide on-site service by contacting the Customer Service Department. Standard rates include an on-site hourly rate, with a one-day minimum plus expenses.

Before You Call...

If you do have a problem, please complete the following checklist before calling Conair:

- Make sure you have all model, serial and parts list numbers for your particular equipment. Service personnel will need this information to assist you.
- Make sure power is supplied to the equipment.
- Make sure that all connectors and wires within and between control systems and related components have been installed correctly.
- Check the troubleshooting guide of this manual for a solution.
- Thoroughly examine the instruction manual(s) for associated equipment, especially controls. Each manual may have its own troubleshooting guide to help you.
- Check that the equipment has been operated as described in this manual.
- Check accompanying schematic drawings for information on special considerations.

Equipment Guarantee

Conair guarantees the machinery and equipment on this order, for a period as defined in the quotation from date of shipment, against defects in material and workmanship under the normal use and service for which it was recommended (except for parts that are typically replaced after normal usage, such as filters, liner plates, etc.). Conair's guarantee is limited to replacing, at our option, the part or parts determined by us to be defective after examination. The customer assumes the cost of transportation of the part or parts to and from the factory.

Performance Warranty

Conair warrants that this equipment will perform at or above the ratings stated in specific quotations covering the equipment or as detailed in engineering specifications, provided the equipment is applied, installed, operated and maintained in the recommended manner as outlined in our quotation or specifications.

Should performance not meet warranted levels, Conair at its discretion will exercise one of the following options:

- Inspect the equipment and perform alterations or adjustments to satisfy performance claims. (Charges for such inspections and corrections will be waived unless failure to meet warranty is due to misapplication, improper installation, poor maintenance practices or improper operation.)
- Replace the original equipment with other Conair equipment that will meet original performance claims at no extra cost to the customer.
- Refund the invoiced cost to the customer. Credit is subject to prior notice by the customer at which time a Return Goods Authorization Number (RGA) will be issued by Conair's Service Department. Returned equipment must be well crated and in proper operating condition, including all parts. Returns must be prepaid.

Purchaser must notify Conair in writing of any claim and provide a customer receipt and other evidence that a claim is being made.

Warranty Limitations

Except for the Equipment Guarantee and Performance Warranty stated above, Conair disclaims all other warranties with respect to the equipment, express or implied, arising by operation of law, course of dealing, usage of trade or otherwise, including but not limited to the implied warranties of merchantability and fitness for a particular purpose.