



WARNING - Reliance on this Manual Could Result in Severe Bodily Injury or Death!

This manual is out-of-date and is provided only for its technical information, data and capacities. Portions of this manual detailing procedures or precautions in the operation, inspection, maintenance and repair of the product forming the subject matter of this manual may be inadequate, inaccurate, and/or incomplete and cannot be used, followed, or relied upon. Contact Conair at info@conairgroup.com or 1-800-654-6661 for more current information, warnings, and materials about more recent product manuals containing warnings, information, precautions, and procedures that may be more adequate than those contained in this out-of-date manual.

Desiccant Tank Retrofit Kit

for CD100/CS101 dehumidifying dryers

Installation

Instructions

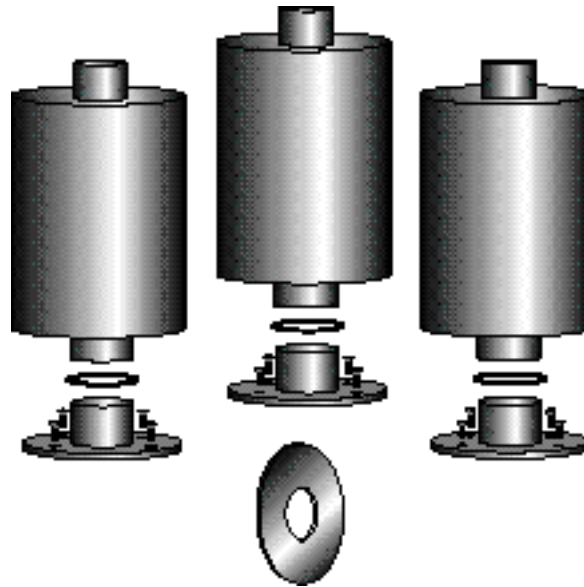

*Instant Access
Parts and Service
(800) 458-1960
(814) 437-6861*

www.conairnet.com



The Conair Group, Inc.
One Conair Drive
Pittsburgh, PA 15202
Phone: (412) 312-6000
Fax: (412)-312-6001

IMD100/0498

© 1998

TABLE OF CONTENTS

INSTALLATION

Unpacking the boxes	1
Removing the sealed desiccant tank assembly	2
Installing the refillable desiccant tank assembly	3
Installing the orifice	4

APPENDIX

Service information	A-1
Warranty/guarantee information	A-2

DISCLAIMER: The Conair Group, Inc., shall not be liable for errors contained in this User Guide or for incidental, consequential damages in connection with the furnishing, performance or use of this information. Conair makes no warranty of any kind with regard to this information, including, but not limited to the implied warranties of merchantability and fitness for a particular purpose.

The Desiccant Tank Retrofit Kit (part #189281) allows you to replace standard sealed desiccant tanks on model CD100 and CS101 dehumidifying dryers with refillable desiccant tanks.

UNPACKING THE BOXES

The retrofit kit includes:

Quantity	Item	Part No.
3	Hollow core desiccant tanks	#184-024-01
3	High temperature O-rings	
3	Flanged tubing	#182-137
12	1/4-20 in. x 1/2 in. bolts	
1	Aluminum orifice 2 7/16 in. OD x 15/16 in. ID	

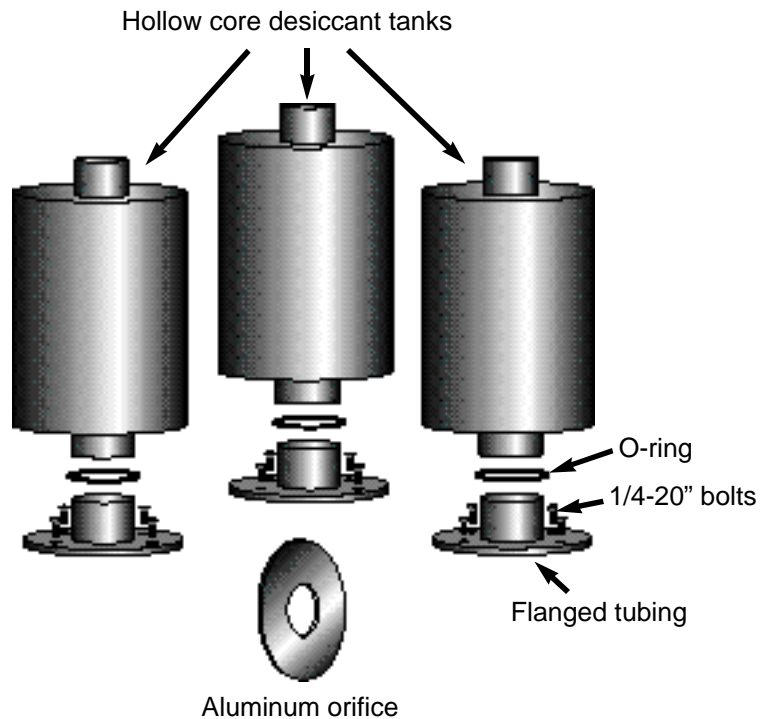

To install the new desiccant tanks you must:

- 1 Remove the sealed desiccant tank assembly.**
- 2 Install the refillable desiccant tank assembly.**
- 3 Install the orifice on the regeneration blower.**

REMOVING THE SEALED DESICCANT TANK ASSEMBLY

NOTE: We recommend that you replace one desiccant tank assembly at a time or mark the hoses as you take them off the tanks. Each hose must be attached to a tank in the same position from which the hose was removed. If you don't replace the hoses correctly, the dryer will not work.

- 1 Stop the dryer.**
- 2 Disconnect and lockout the main power source.**
- 3 Remove the dryer's side panel.**

- 4 Disconnect the hose from a desiccant tank.**

Loosen the hose clamp with a screw driver.

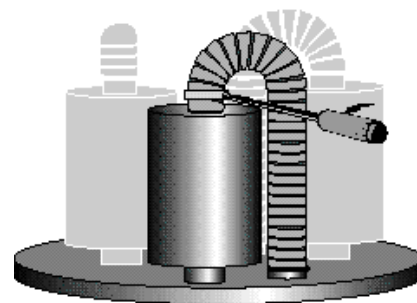

- 5 Lift the tank off the carousel assembly.**

- 6 Remove the flanged tubing.**

Loosen the bolts with a screw driver.

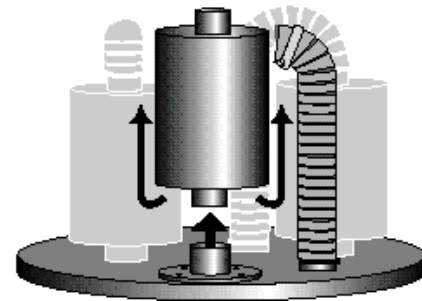

- 7 Repeat these steps to remove each tank.**

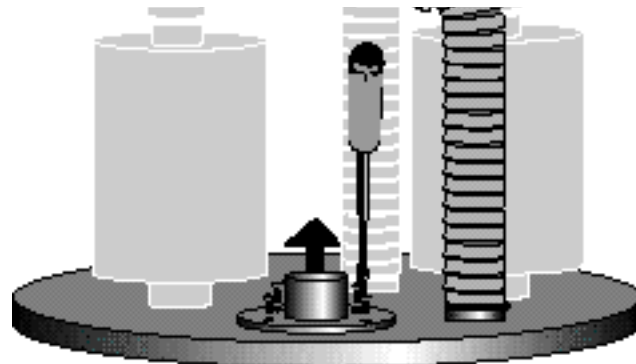

You must replace the old flanged tubing with the flanged tubing that was supplied with the kit.

INSTALL THE REFILLABLE DESICCANT TANK ASSEMBLY

- 1 Attach the new flanged tubing to the carousel bed plate.** Use the 1/4-20" bolts.

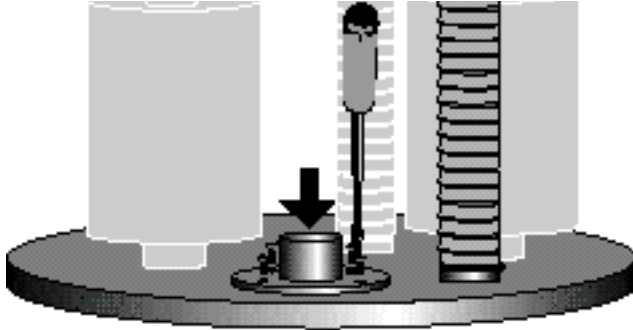

- 2 Lubricate the O-ring with petroleum jelly.**

- 3 Slide the O-ring over the flanged tubing.**
Make sure the O-ring sits securely at the base of the tubing.

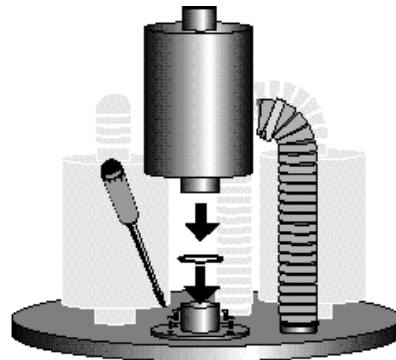

- 4 Place the new refillable desiccant tank over the flanged tubing.** The beveled bottom of the desiccant tube should sit securely on top of the O-ring.

- 5 Reattach the flexible air hose.** Make sure the hose is attached to a tank in the same position from which the hose was removed.

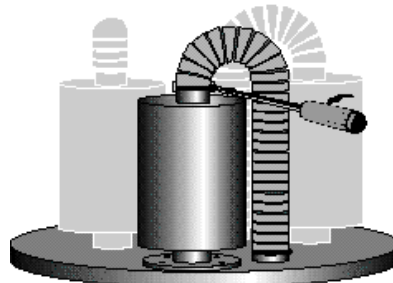

- 6 Repeat these steps for each tank.**

INSTALLING THE ORIFICE

The orifice must be installed on the regeneration blower to restrict air flow.

- 1 Remove the left side panel of the dryer.**

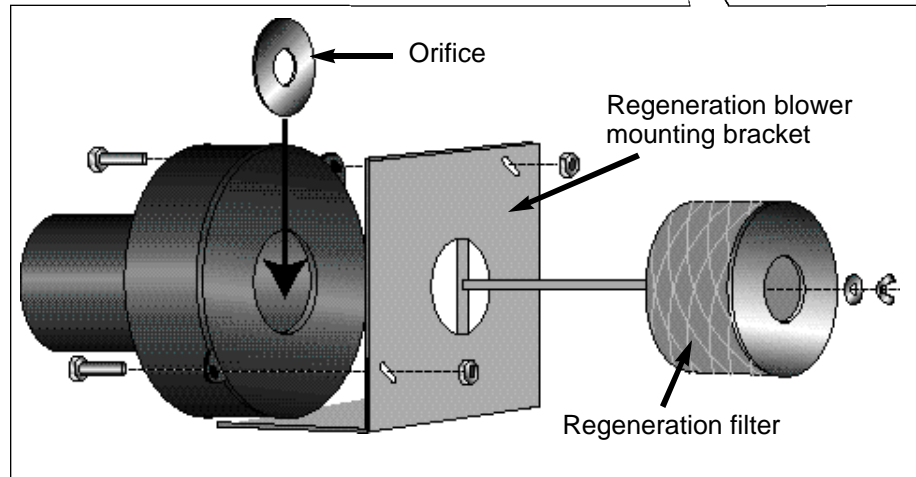
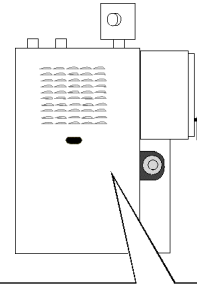

- 2 Remove the regeneration filter.** Removing the filter is not necessary, but it will provide easier access to the regeneration blower bracket.
- 3 Remove the two bolts** that hold the regeneration blower to its mounting bracket.
- 4 Move the blower away from the bracket.** Support the back of the blower with your hand so that it doesn't fall.
- 5 Insert the orifice into the blower opening.**
- 6 Move the blower back onto the bracket.** Make sure the orifice is placed between the blower and the bracket.
- 7 Replace the bolts and tighten.**
- 8 Replace the regeneration filter.**
- 9 Replace the side panel of the dryer.**

Conair has made the largest investment in customer support in the plastics industry. Our service experts are available to help with any problem you might have installing and operating your equipment. Your Conair sales representative also can help analyze the nature of your problem, assuring that it did not result from misapplication or improper use.

WE'RE HERE TO HELP

To contact Customer Service personnel, call:



From outside the United States, call: 814-437-6861

You can commission Conair service personnel to provide on-site service by contacting the Customer Service Department. Standard rates include an on-site hourly rate, with a one-day minimum plus expenses.

HOW TO CONTACT CUSTOMER SERVICE

If you do have a problem, please complete the following checklist before calling Conair:

- Make sure you have all model, serial and parts list numbers for your particular equipment. Service personnel will need this information to assist you.
- Make sure power is supplied to the equipment.
- Make sure that all connectors and wires within and between control systems and related components have been installed correctly.
- Check the troubleshooting guide of this manual for a solution.
- Thoroughly examine the instruction manual(s) for associated equipment, especially controls. Each manual may have its own troubleshooting guide to help you.
- Check that the equipment has been operated as described in this manual.
- Check accompanying schematic drawings for information on special considerations.

BEFORE YOU CALL ...

Additional manuals and prints for your Conair equipment may be ordered through the Customer Service or Parts Departments for a nominal fee.

EQUIPMENT GUARANTEE

Conair guarantees the machinery and equipment on this order, for a period as defined in the quotation from date of shipment, against defects in material and workmanship under the normal use and service for which it was recommended (except for parts that are typically replaced after normal usage, such as filters, liner plates, etc.). Conair's guarantee is limited to replacing, at our option, the part or parts determined by us to be defective after examination. The customer assumes the cost of transportation of the part or parts to and from the factory.

PERFORMANCE WARRANTY

Conair warrants that this equipment will perform at or above the ratings stated in specific quotations covering the equipment or as detailed in engineering specifications, provided the equipment is applied, installed, operated and maintained in the recommended manner as outlined in our quotation or specifications.

Should performance not meet warranted levels, Conair at its discretion will exercise one of the following options:

- Inspect the equipment and perform alterations or adjustments to satisfy performance claims. (Charges for such inspections and corrections will be waived unless failure to meet warranty is due to misapplication, improper installation, poor maintenance practices or improper operation.)
- Replace the original equipment with other Conair equipment that will meet original performance claims at no extra cost to the customer.
- Refund the invoiced cost to the customer. Credit is subject to prior notice by the customer at which time a Return Goods Authorization Number (RGA) will be issued by Conair's Service Department. Returned equipment must be well crated and in proper operating condition, including all parts. Returns must be prepaid.

Purchaser must notify Conair in writing of any claim and provide a customer receipt and other evidence that a claim is being made.

WARRANTY LIMITATIONS

Except for the Equipment Guarantee and Performance Warranty stated above, Conair disclaims all other warranties with respect to the equipment, express or implied, arising by operation of law, course of dealing, usage of trade or otherwise, including but not limited to the implied warranties of merchantability and fitness for a particular purpose.