

FOR ELEVATING BLENDING EQUIPMENT

- **Sturdy construction**
Long-lasting construction provides years of operation.
- **RAL 9003 paint**
Painted for medical cleanroom applications.
- **Easy cleanout**
Built-in reservoir for fast and thorough material clean out.
- **Optional cleanroom casters**
Make movement easy. (Model TBBS01 only)
- **Easy to place and move**
Stand design incorporates fork-lift user-friendly provision.



Model TBBS01
Shown with optional casters.
TB Blender sold separately.



Model TBBS02
TB Blender sold separately.

SPECIFICATIONS

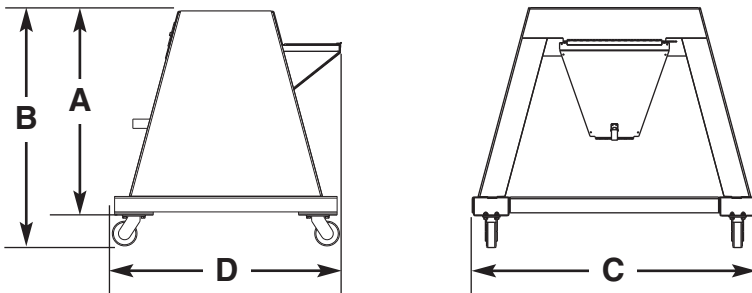

MODELS	TBBS01	TBBS02
Blender applications	TB45, TB100	TB45, TB100, TB250, TB500
Dimensions inches {mm}		
A - Height	33.0 {838}	32.5 {826}
B - Height with casters	37.9 {963}	NA
C - Width	45.0 {1143}	53.5 {1359}
D - Depth	36.7 {932}	48.0 {1219}
Reservoir capacity ft ³ {m ³ }	1 {0.02}	2 {0.05}
Takeaway tube OD in {mm}*	1.5, 1.75, 2 {38.1, 44.5, 50.8}	1.5, 1.75, 2, 2.25, 2.5, 3 {38.1, 44.5, 50.8, 57.2, 63.5, 76.2}

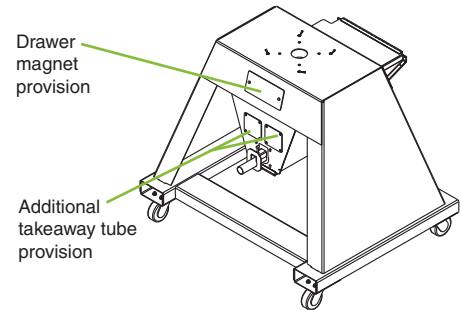

MOUNTING PATTERN

Model TBBS01

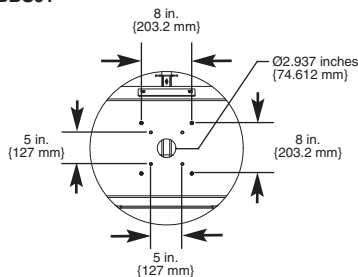

Model TBBS02

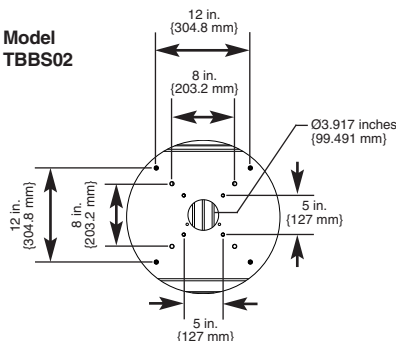

SPECIFICATION NOTES:

* Blender stands are provided with one takeaway tube as standard. Up to two additional takeaway tubes can be included as an option.
Specifications can change without notice. Check with a Conair representative for the most current information.

